

- NOTES:
1. MATERIALS: "G" STYLE
 - 1.1 SHELL, FERRULE
BRASS PER QQ-B-626
FINISH: GOLD, OVER
ELECTROLESS NICKEL
PER MIL-G-45204, TYP 2, CLASS 1
 - 1.2 INSERT
PEEK, GLASS FILLED PER
MIL-P-46183
 - 1.3 CONTACTS
COPPER ALLOY
FINISH: GOLD PER MIL-G-45204
 - 1.4 GASKETS
SILICONE RUBBER PER AMS 3304
 - 1.5 ALTERNATE SHELL MATERIALS
AND FINISHES:
"M" STYLE: BRASS, WITH
ELECTROLESS NICKEL FINISH
PER AMS-C-26074, CLASS 4, GRADE B
"A" STYLE: BRASS, WITH GOLD PLATE,
BLACK CHROMATE
"K" STYLE: STAINLESS STEEL,
300 SERIES, WITH PASSIVATION

REVISION HISTORY		
REVISION	DATE	COMMENT
0	02 /10 / 17	INITIAL RELEASE
A	07/01/20	DIM CHANGES

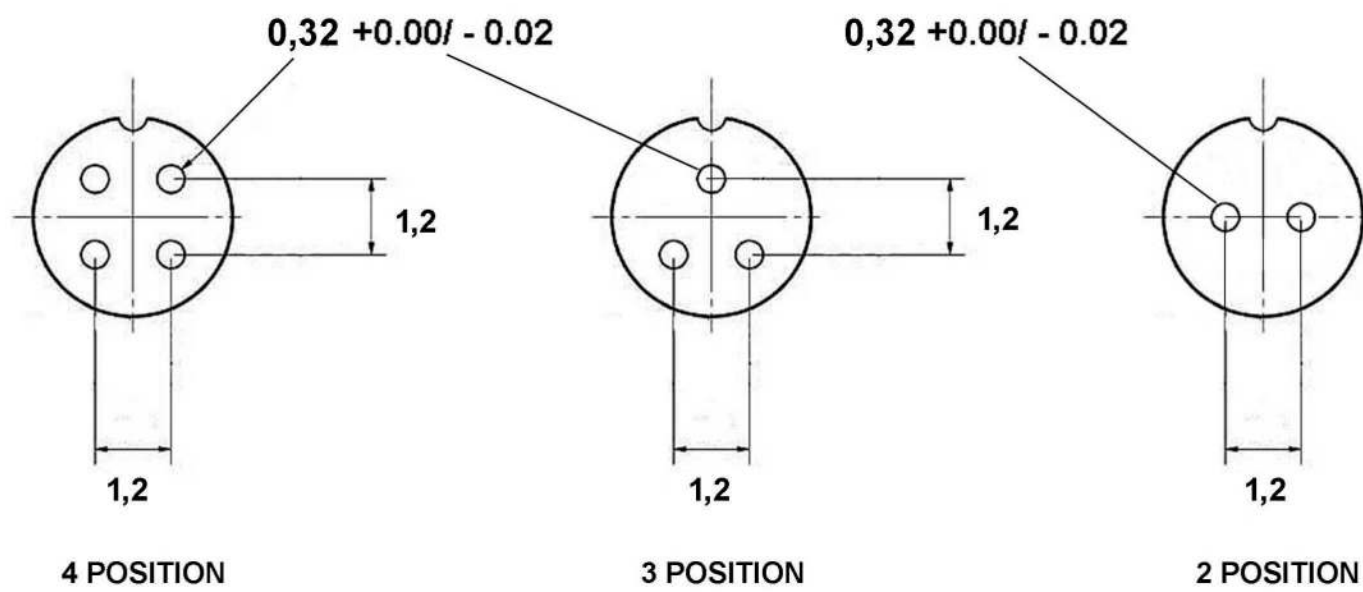
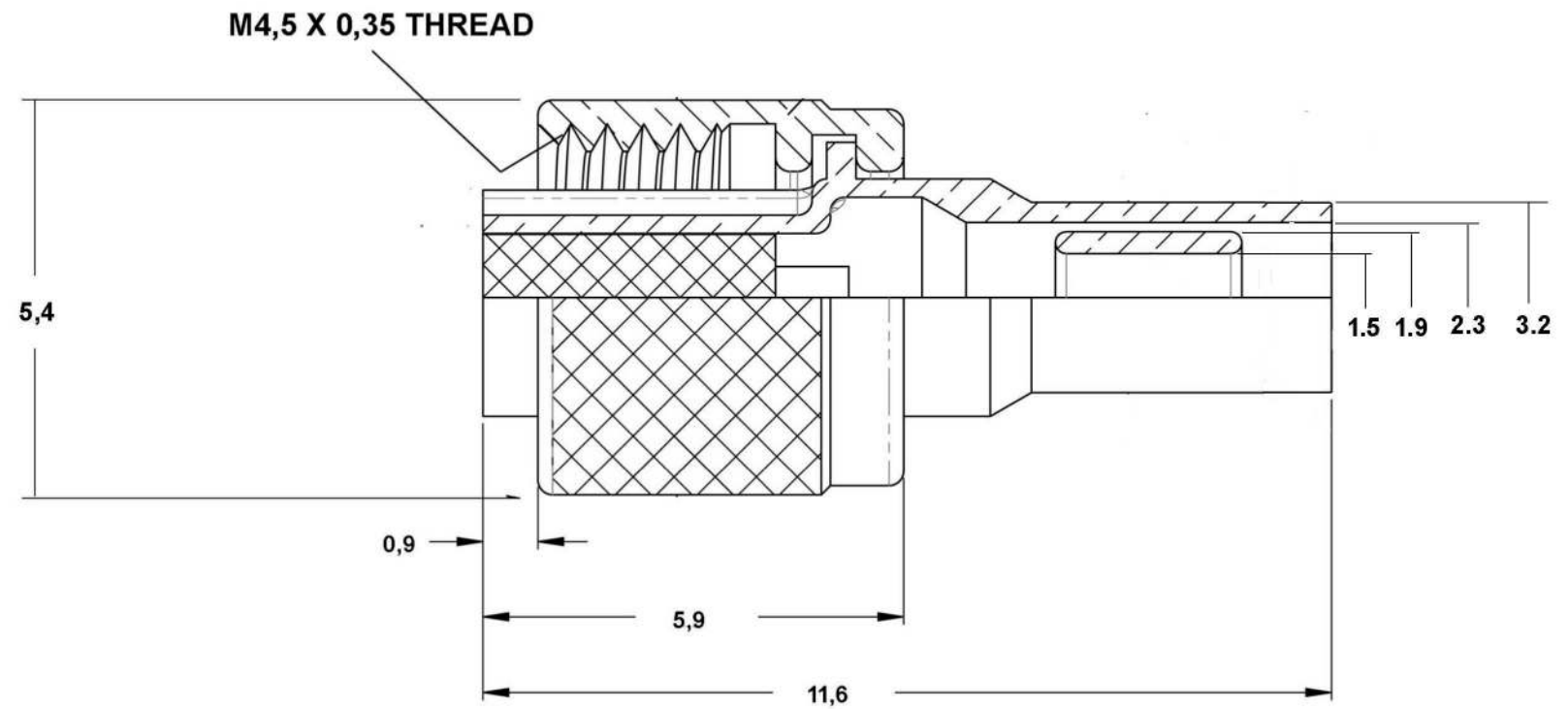

SAMPLE PN: MSWU-G-B-04S

UNLESS OTHERWISE NOTED: DIMENSIONS ARE IN MILLIMETERS DO NOT SCALE THIS DRAWING .X DECIMALS ARE ±0.5 .XX DECIMALS ARE ±0.25 .XXX DECIMALS ARE ±0.13 ANGLES ARE ±0.5°	DRAWING	SC	MILSPECWEST - MICRO PRODUCTS CAGE CODE: 3HD49	
	CHECKED	TS	DESCRIPTION: ULTRA PLUG CONNECTOR	
	Q.A.	KB	DWG. NO. MSWU - * - B - 0 * S	REVISION: A SHEET 1

THIS DOCUMENT IS SOLE PROPERTY OF MILSPECWEST AND IS ISSUED IN STRICT CONFIDENCE THAT IT WILL NOT BE REPRODUCED IN ANY WAY OR USED TO SOLICIT BUSINESS OF A COMPETITIVE NATURE. DISTRIBUTION OF THIS DOCUMENT IS PROHIBITED UNLESS WRITTEN CONSENT IS OBTAINED FROM MILSPECWEST. THIS DOCUMENT IS SUITABLE FOR ENGINEERING EVALUATION AND MAY BE USED IN TECHNICAL SPECIFICATIONS.