

BCV200-350-8

20 kW Combo Unit System

The Bel Power Solutions BCV200-350-8 is a 20 kW combo unit system consisting of three subsystems: 15 kW bidirectional inverter/charger, 4 kW down converter (12 V), 1 kW down converter (24 V).

This all-in-one eMobility unit combines three products, creating a convenient and compact solution that helps reduce cabling.

The inverter/charger powers up to 15 kW in either direction. Features include high efficiency, high reliability, low total harmonic distortion (AC), low output voltage noise (DC), and excellent dynamic response to load/input changes.



FEATURES

- Up to 15 kW Power in Charge and Export Mode
- Typical Efficiency 92 %
- Charge Mode
 - AC Input 90 – 264 VAC
 - HV Output 250 – 435 VDC
- Export Power Mode:
 - Output 120/240 VAC (Split phase), 50/60 Hz
- 4 kW Down Converter - 12 V Output (CAN adjustable)
- 1 kW Down Converter - 24 V Output (CAN adjustable)
- Over temperature, Output Over voltage & Over current Protection
- CAN bus serial interface
- SAE J1939 Compliant CAN Control and Monitoring
- SAE J1455 Compliant Environmental Standards
- IP67 and IP6K9K Rating

APPLICATIONS

- Hybrid and Electric Vehicles
- Medium through heavy duty, on and off highway vehicles

1. MODEL SELECTION

MODEL	DESCRIPTION
BCV200-350-8	Combo Unit System
BCV200-CON-KIT	Mating cable harness and connector kit

2. INVERTER CHARGER SUBSYSTEM

2.1 AC SIDE CHARGE MODE INPUT

PARAMETER	DESCRIPTION / CONDITIONS	MIN	NOM	MAX	UNIT
Input Voltage	Nominal operating range Absolute operating range	100 90	230	240 264	VAC
Input Current	Charge mode: at 195 – 265 VAC at 90 – 195 VAC			70 16	ARMS
Input Frequency		47	50/60	63	Hz
Leakage Current	at 264 VAC, 63 Hz			10	mA
Line Harmonic Current	EN 61000-3-12, 120 VAC and 240 VAC, $P_{HV} = 250 \text{ VDC} * 40 \text{ ADC}$ and $P_{HV} = 435 \text{ VDC} * 34 \text{ ADC}$	16			ARMS
Power Factor	$V_{AC_IN} = 240 \text{ V}_{RMS}$, $P_{HV} = 250 \text{ VDC} * 40 \text{ ADC}$ and $435 \text{ VDC} * 34 \text{ ADC}$	0.95			
Inrush Current	Pre-charge mechanism				
Efficiency	at $V_{AC_IN} = 240 \text{ V}_{RMS}$, $V_{HV} = 375 \text{ VDC}$ (nom), $I_{HV} = 40 \text{ ADC}$, $T_{COOLANT} = 20^\circ\text{C}$		92		%

2.2 AC SIDE EXPORT MODE OUTPUT

PARAMETER	DESCRIPTION / CONDITIONS	MIN	NOM	MAX	UNIT
Output Voltage	Split-phase 120 / 240 VAC	2x 110	2x 120	2x 128	VAC
Output Current	Export mode: Phase - L1, L2 Neutral - N		60 40		ARMS
Output Power	at > 375 VDC / 240 VAC			14.4	kVA
Frequency	CAN selectable 50 or 60 Hz Mode: 50 Hz Mode: 60 Hz	49.9 59.9	50 60	50.1 60.1	Hz
Efficiency	at $V_{HV} = 375 \text{ VDC}$ (nom), 435 VDC (max), $I_{AC_OUT1} = I_{AC_OUT2} = 55 \text{ AAC}$, $T_{COOLANT} = 20^\circ\text{C}$		92		%
Load Step Response	Load Step 1 6 ARMS to 30 ARMS and back Load Step 2 30 ARMS to 60 ARMS and back Voltage deviation Response time	-30 %	0	+30 % 4	VAC ms
Total Harmonic Distortion	at 250 – 435 VDC; Load 0 – 60 ARMS			3	%
Turn On/Off Delay	Export Mode: Turn-On Delay Turn-Off Delay			3 1	s

2.3 HV SIDE

PARAMETER	DESCRIPTION / CONDITIONS	MIN	NOM	MAX	UNIT
Output Power				15	kW
Output Type	DC current source with 100/120 Hz sine wave ripple component				
Output Voltage	Not regulated; depends on battery voltage	250	375	435	VDC
Output Current	Average output charging current adjustable via CAN Including AC ripple component (AC + DC)			40 52	ADC ARMS
Ripple	100/120 Hz	0		80	APK
Input Capacitance			55		μF



2.4 PROTECTIONS

PARAMETER	DESCRIPTION / CONDITIONS	MIN	NOM	MAX	UNIT
AC Over Current Protection	Export mode: 2 s overload Output phase voltage reduced to the 70 V _{RMS}			120 60	A _{RMS}
AC Over Voltage Protection	at 264 V _{RMS} , Hysteresis 5 V _{RMS}	265	270	275	V _{RMS}
AC Under Voltage Protection	at 90 V _{RMS}		83 88	85 90	V _{RMS}
HV Over Current Protection	CAN adjustable			40	A
HV Over Voltage Protection	Latch type, CAN adjustable, max. OVP duration 1 ms	250		435	VDC
HV Under Voltage Protection	UVP duration 1 s, hysteresis 20 VDC		220		VDC
Input & Output Fuse Protection	AC input fuse: EVSE circuit breaker - Type C		100		A
	AC output fuse: N/A				
	HV input fuse (450 VDC minimum): Aux_Supply_12 V fuse: all 12 V shall be fused by external automotive fuse		63 7.5		A A
Over Temperature Protection	Converter shutdown at T _{COOLANT} higher than	60			°C
Appliance Leakage Current Interrupter (ALCI)	Trip range (>30 ms inverter shut down) Maximum turn off delay from ALCI trip point	20		20 30	mA ms

3. 12 V DOWN CONVERTER

PARAMETER	DESCRIPTION / CONDITIONS	MIN	NOM	MAX	UNIT
Output Voltage	Adjustable by CAN	9	12	14.4	V
Output Current	Adjustable by CAN	0		278	A
Continuous Power		0		4000	W
Efficiency	at V _{OUT12} = 14.4 V, V _{HV} = 350 V, I _{OUT12} = 278 A		90		%
Remote Sense	at V _{OUT12} = 14.4 V cable drop at maximum load			0.5	V
Turn On/Off Delay	Rise time (C _{ext} = 0 μF)			300	ms
	Power-on-delay (From applying of HV voltage + CAN & signal enables to V _o = 90%)			2	s
V_{OUT12} PROTECTION					
Output Over Current Protection	Constant current	278			A
Output Over Voltage Protection	Maximum OV duration 1 ms	17			V
Output Under Voltage Protection	Maximum UV duration 1 s			8	V
Reverse Polarity Protection	According to SAE J1455				
Fuse Protection	No internal fuse on V _{OUT12} output				



4. 24 V DOWN CONVERTER

PARAMETER	DESCRIPTION / CONDITIONS	MIN	NOM	MAX	UNIT
Output Voltage	Adjustable by CAN	18	24	28.8	V
Output Current	Adjustable by CAN	0		34.7	A
Continuous Power		0		1000	W
Efficiency	at $V_{OUT24} = 28.8$ V, $V_{HV} = 350$ V, $I_{OUT24} = 34.7$ A		90		%
Turn On/Off Delay	Rise time ($C_{ext} = 0$ μ F) Power-on-delay (From applying of HV voltage + CAN & signal enables to $V_o = 90\%$)			300 2	ms s
V _{OUT24} PROTECTION					
Output Over Current Protection	Constant current	34.7			A
Output Over Voltage Protection	Maximum OV duration 1 ms	29			V
Output Under Voltage Protection	Maximum UV duration 1 s			16	V
Reverse Polarity Protection	According to SAE J1455				
Fuse Protection	No internal fuse - electronic current limitation				

5. MONITORING AND CONTROL SIGNALS

PARAMETER	DESCRIPTION / CONDITIONS
IGN (Key Switch)	CAN communication enable Level High = Enable
Control Pilot	Function and levels according to SAE J1772 Duty cycle accuracy +/-2% in range 20 – 96%. Duty cycle accuracy -2/+5% in range 10 – 20%.
Proximity Detection	Function and levels according to SAE J1772
VBAT	12 V battery voltage input (typ. input current 4.5 A, max 6 A). Used to supply internal aux converter. Input protected against reverse connected battery by serial diode.
EVSE_WAKE_OUT	Energy taken from VBAT. High side switch to wake VCU (Vehicle Control Unit) and other vehicle control modules. Output is protected by resettable PTC fuse.
CAN_BAUD_RATE	CAN bus speed; CAN speed settings is detected only at start up when 12 V voltage is applied. 500 kbit/s – signal not connected / left floating 250 kbit/s – signal grounded; connected to 12V_RTN

6. ENVIRONMENTAL SPECIFICATIONS

PARAMETER	DESCRIPTION / CONDITIONS	MIN	NOM	MAX	UNIT
Operating Temperature	T _{COOLANT} at full load T _{COOLANT} at 90% power derating	-30 -30		+50 +60	°C
Storage Temperature		-40		+85	°C
Altitude	SAE J1455, Operating: Non-Operating: 18.6 kPa absolute pressure			4000 12200	m
Humidity	SAE J1455				
Thermal Shock	SAE J1455, T _{AMB} = -40°C to +85°C (no coolant cycling)				
Vibration	Swept sine vibration MIL-STD-202G, corrected to 5G Random vibration MIL-STD-202G & SAE J1455				
Protection	IP67 and IP6K9K, when all mating connectors are installed, and all unused pins are sealed.				



7. COOLING SPECIFICATIONS

PARAMETER	DESCRIPTION / CONDITIONS
Cooling Type	Liquid cooled
Inlet Coolant Temperature	-30°C /+60°C (90% derating above +50°C)
Coolant Medium / Mixture	50/50 ethylene glycol/distilled water with proper corrosion inhibitor
Coolant Volume In Cooling System	0.3 L
Minimum / Maximum Coolant Flow	7 – 10 LPM, for short-term operation, 20% duty cycle, 15 LPM can be used
Maximum Coolant Pressure	26 psig (1.8 bar)
Typical Pressure Drop	5.8 psig (0.4 bar) at coolant temperature +20°C
Inlet/Outlet Cooling System Connection	1/2" Barbed hose fittings
Material Of Cooling System	Fittings: Stainless steel AISI 304, FKM Chassis: AISi10Mg Bottom cover: AlMg2.5

8. SAFETY, REGULATORY AND EMI SPECIFICATIONS

PARAMETER	DESCRIPTION / CONDITIONS	CLASS / LEVEL / CRITERION
Radiated Emission	FCC15	Class A
Conducted Emission	FCC15, CISPR 32	Class A
Electrostatic Discharge	IEC 61000-4-2	Performance Criterion C
Radiated Electromagnetic Field	IEC 61000-4-3, SAE J1113/21	Performance Criterion B, Status 3
Electrical Fast Transient (EFT) /Burst	IEC 61000-4-4; Level 2 (± 5 kHz)	Performance Criterion C
Surge Immunity	IEC 61000-4-5; Level 3 surge (± 1 kV DM and ± 2 kV CM)	Performance Criterion C
RF Conducted Immunity	IEC 61000-4-6; Level 3 (10 V, 0.15...80 MHz, AM 80%, 1 kHz)	Performance Criterion C
Bulk Current Injection (BCI)	ISO 11452-4; 1-400 MHz, 60 mA	Class A
Capacitive Coupling Clamp (CCC)	ISO 7637-3; -60 V, +40 V,	Class A
Flicker Tests	IEC 61000-3-3	Performance Criterion B
Insulation (factory tested)	AC Input to HV output: AC Input to chassis: HV Output to chassis: Signals, 12 V Output and 24 V Output have negative terminal connected to chassis PE	2500 VDC * 2500 VDC * 2500 VDC *

* Power transformers and safety insulation is designed to meet 4242 VDC (3000 VAC) between AC input and HV output and also between AC input or HV output and low voltage signals including 12 V and 24 V outputs.

9. CONNECTORS

PARAMETER	DESCRIPTION / CONDITIONS	MANUFACTURER	MPN
AC Side Charge Connector*	Inverter Charger side Mating connector	Deutsch	HDP24-24-7PN-C038 HDP26-24-7SN-C038
AC Side Export Connector	Inverter Charger side Mating connector	Deutsch	HDP24-24-9SE HDP26-24-9PE-L015
HV Power Connector	Inverter Charger side Mating connector	Amphenol	PL082X-61-6 PL182X-61-6
V _{OUT12} Power Connector	Inverter Charger side Mating connector	Amphenol	PL082X-301-10M8 PL182X-301-70
Signal Connector	Inverter Charger side Mating connector	Deutsch	DRC13-24PA DRC16-24SA

* Connector will contain two signal pins for Control Pilot and proximity signals.



9.1 AC SIDE CHARGE CONNECTOR

PIN	FUNCTION
1	Control Pilot *
2	Proximity*
3	L2 or N - Input
4	L1 - Input
5	Not Used
6	PE (connected to chassis)
7	Not Used

* Function and levels according to SAE J1772;
Insulated from AC side; Referenced to Vout12 RTN = PE

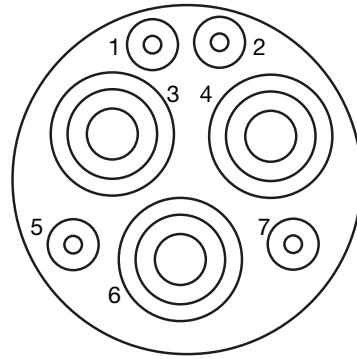

9.2 AC SIDE EXPORT CONNECTOR

PIN	FUNCTION
R	N - Output
S	L1 - Output
T	PE*
U	L2 - Output
V	PE* (connected to chassis)
W	PE*
X	PE*
Y	PE*
Z	PE*

* All PE terminals (T, V, W, X, Y, Z) shall be connected together to keep safety rating requirements.

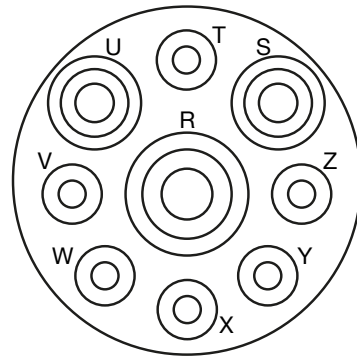

9.3 HV POWER CONNECTOR

Terminal A – HVDC + (High voltage positive)
Terminal B – HVDC – (High voltage negative)

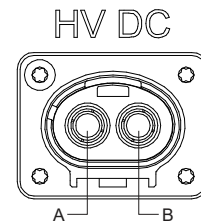

9.4 V_{OUT12} POWER CONNECTOR

Terminal A – Vout12+
Terminal B – Vout12- (Return - connected to chassis)

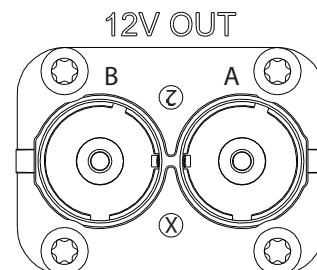

9.5 SIGNAL CONNECTOR

PIN	FUNCTION	
1	Vout24+	+24 V output
2	Vout24+	+24 V output
3	Control Pilot Out	Copy of Control Pilot
4	+SENSE Vout12	Remote sense for Vout12
5	Reserved	NA
6	CAN_L_int	Internal CAN - for production purpose, DO NOT CONNECT
7	Vout24+	+24 V output
8	Vout24+	+24 V output
9	VBAT	12 V supply of internal Bias
10	HVIL_OUT	HVIL loop OUT
11	IGN	(Key Switch) Supply of CAN and Bias convertor enable.
12	CAN_H_int	Internal CAN - for production purpose, DO NOT CONNECT
13	Vout24-	24 V and VBAT RTN (connected to chassis)
14	Vout24-	24 V and VBAT RTN (connected to chassis)
15	VBAT	12 V supply of internal bias
16	HVIL_IN	HVIL loop IN
17	CAN_BAUD_RATE	Open – 500 kBit; Grounded – 250 kbit
18	CAN_H	CAN Bus H
19	Vout24-	24 V and VBAT RTN (connected to chassis)
20	Vout24-	24 V and VBAT RTN (connected to chassis)
21	Reserved	NA
22	-SENSE Vout12	Remote sense for Vout12
23	EVSE_WAKE_OUT	Signal to wake up Vehicle Control Unit (VCU module)
24	CAN_L	CAN Bus L

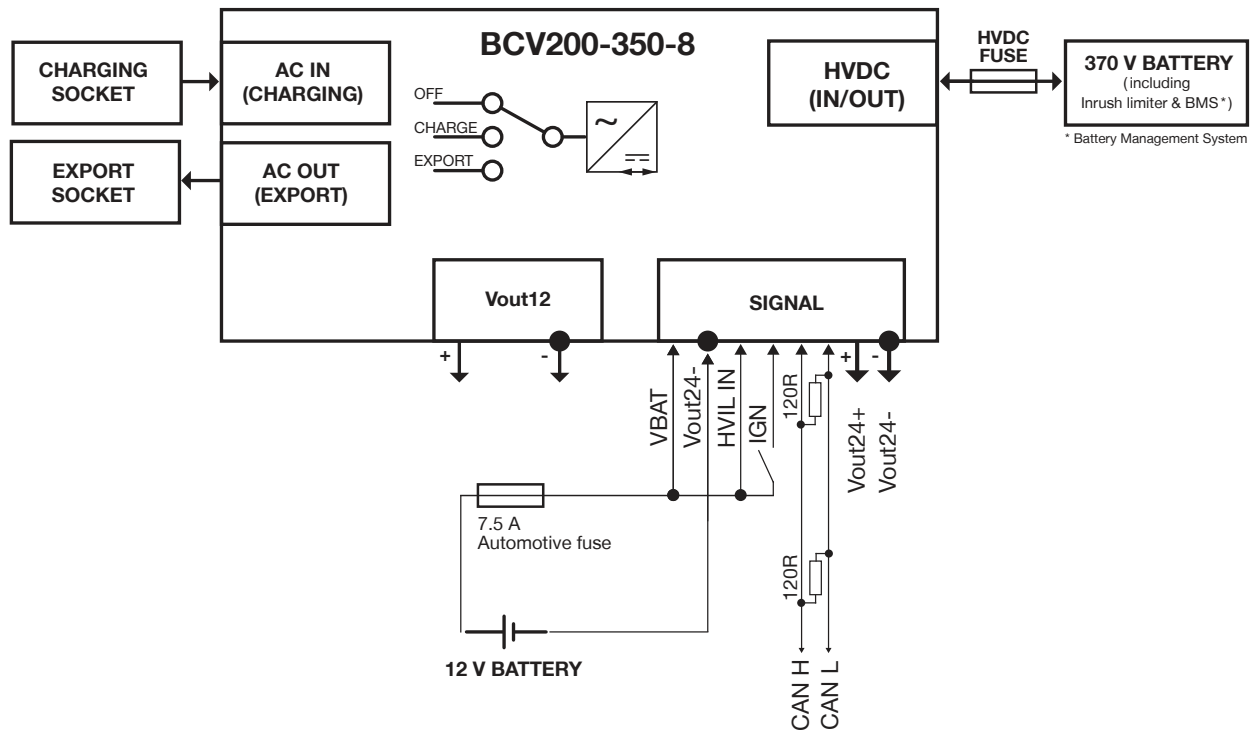
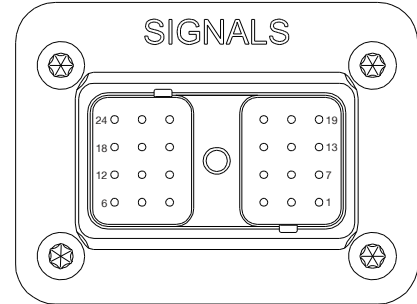
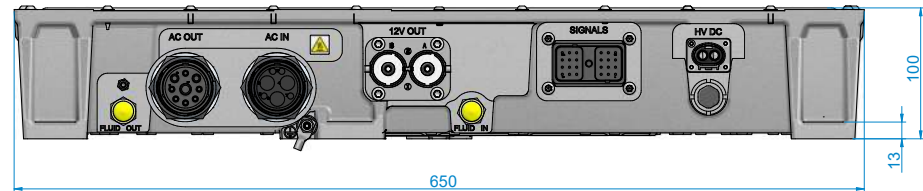

Figure 1. Schematic diagram



10. MECHANICAL SPECIFICATIONS

PARAMETER	DESCRIPTION / CONDITIONS	UNIT
Dimensions	650 x 100 x 491 25.59 x 3.94 x 19.33	mm in
Weight	35.7	kg
Enclosure Material	Aluminum alloy, AISi10Mg	



6x MOUNTING HOLES Ø 11
RECOMMENDED FOR SCREWS
M10 OR 3/8" UNC

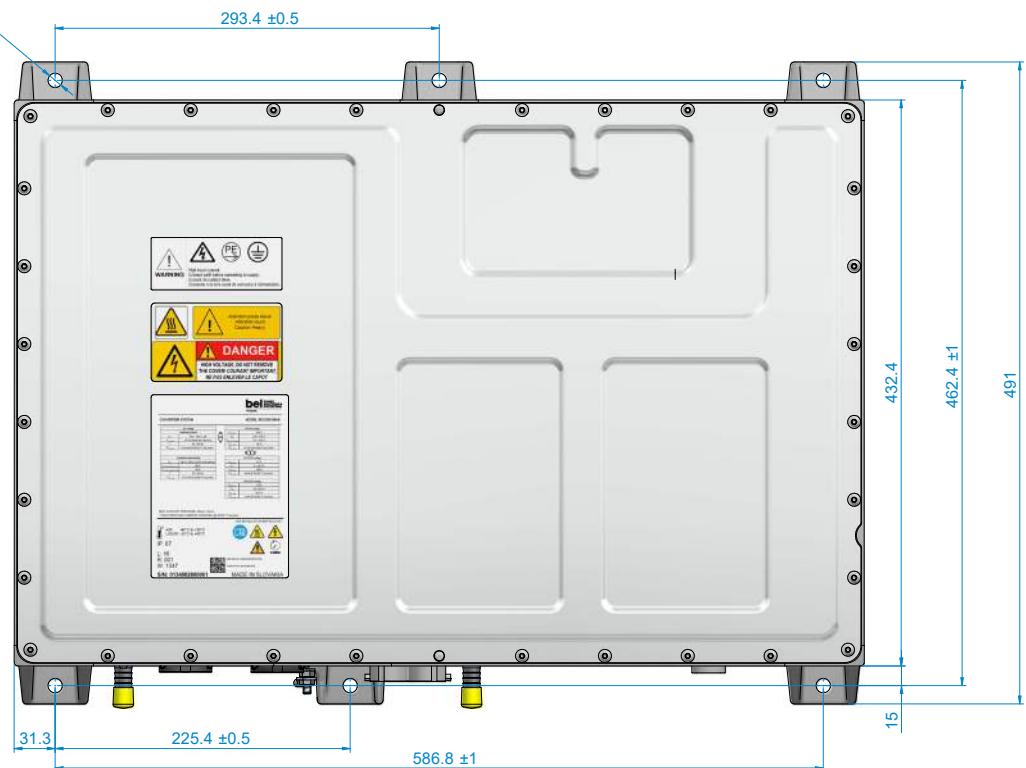

Figure 2. Mechanical Drawing

For more information on these products consult: tech.support@psbel.com

NUCLEAR AND MEDICAL APPLICATIONS - Products are not designed or intended for use as critical components in life support systems, equipment used in hazardous environments, or nuclear control systems.

TECHNICAL REVISIONS - The appearance of products, including safety agency certifications pictured on labels, may change depending on the date manufactured. Specifications are subject to change without notice.

