

EIA/ITU PABX SLIC with 30mA Loop Feed

The Intersil SLIC incorporates many of the BORSHT functions on a single IC chip. This includes DC battery feed, a ring relay driver, supervisory and hybrid functions. This device is designed to maintain transmission performance in the presence of externally induced longitudinal currents. Using the unique Intersil dielectric isolation process, the SLIC can operate directly with a wide range of station battery voltages.

The SLIC also provides selective denial of power. If the PBX system becomes overloaded during an emergency, the SLIC will provide system protection by denying power to selected subscriber loops.

The Intersil SLIC is ideally suited for the design of new digital PBX systems, by eliminating bulky hybrid transformers.

Part Number Information

PART NUMBER	TEMP. RANGE (°C)	PACKAGE	PKG. DWG. #
HC3-5502B-5	0 to 75	24 Ld PDIP	E24.6
HC4P5502B-5	0 to 75	28 Ld PLCC	N28.45

Features

- Capable of 12V or 5V (V_{B+}) Operation
- Monolithic Integrated Device
- DI High Voltage Process
- Compatible With Worldwide PBX Performance Requirements
- Controlled Supply of Battery Feed Current for Short Loops (30mA)
- Internal Ring Relay Driver
- Low Power Consumption During Standby
- Switch Hook, Ground Key and Ring Trip Detection Functions
- Selective Denial of Power to Subscriber Loops

Applications

- Solid State Line Interface Circuit for Analog and Digital PBX Systems
- Direct Inward Dial (DID) Trunks
- Voice Messaging PBXs
- Related Literature
 - AN549, The HC-5502S/4X Telephone Subscriber Line Interface Circuits (SLIC)
 - AN571, Using Ring Sync with HC-5502A and HC-5504 SLICs

Pinouts

**HC-5502B (PDIP)
TOP VIEW**

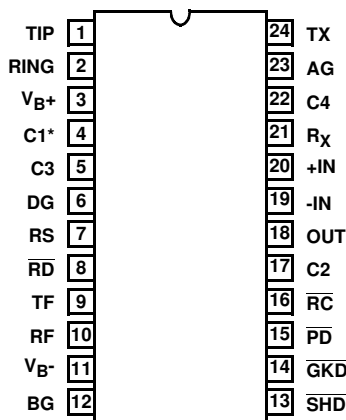

**HC-5502B (PLCC)
TOP VIEW**

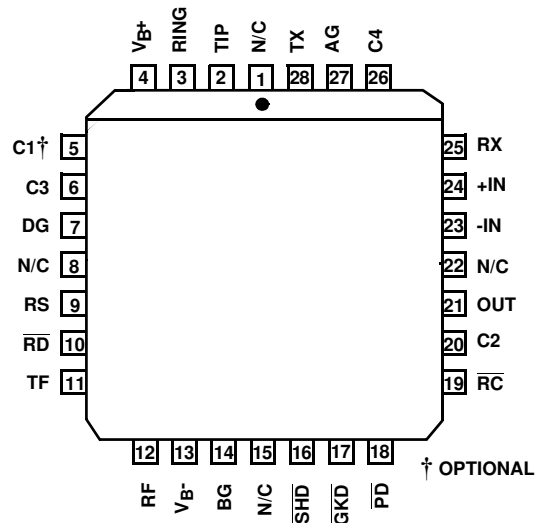

Absolute Maximum Ratings (Note 1)

Supply Voltage	
(V _{B-})	-60 to 0.5V
(V _{B+})	-0.5 to 15V
(V _{B+} - V _{B-})	.75V
Relay Drive Voltage (V _{RD})	-0.5 to 15V

Operating Conditions

Relay Driver Voltage (V _{RD})	5V to 12V
Positive Supply Voltage (V _{B+})	4.75V to 5.25V or 10.8V to 13.2V
Negative Supply Voltage (V _{B-})	-42V to -58V
High Level Logic Input Voltage	2.4V
Low Level Logic Input Voltage	0.6V
Loop Resistance (R _L)	200 to 1200Ω
Operating Temperature Range	
HC-5502B-5	0°C to 75°C

Thermal Information

Thermal Resistance (Typical, Note 2)	θ _{JA} (°C/W)
PDIP Package	65
PLCC Package	65
Maximum Junction Temperature (Hermetic Package)	175°C
Maximum Junction Temperature (Plastic Package)	150°C
Maximum Storage Temperature Range	-65°C to 150°C
Maximum Lead Temperature (Soldering 10s)	300°C
(PLCC - Lead Tips Only)	

Die Characteristics

Transistor Count	183
Diode Count	33
Die Dimensions	.137 mils x 102 mils
Substrate Potential	V _{B-}
Process	Bipolar-DI

CAUTION: Stresses above those listed in "Absolute Maximum Ratings" may cause permanent damage to the device. This is a stress only rating and operation of the device at these or any other conditions above those indicated in the operational sections of this specification is not implied.

NOTES:

1. Absolute maximum ratings are limiting values, applied individually, beyond which the serviceability of the circuit may be impaired. Functional operability under any of these conditions is not necessarily implied.
2. θ_{JA} is measured with the component mounted on an evaluation PC board in free air.

Electrical Specifications Unless Otherwise Specified, V_{B-} = -48V, V_{B+} = 12V and 5V, AG = BG = DG = 0V, Typical Parameters T_A = 25°C. Min-Max Parameters are Over Operating Temperature Range

PARAMETER	TEST CONDITIONS	MIN	TYP	MAX	UNITS
On Hook Power Dissipation	I _{LONG} = 0, V _{B+} = 12V (Note 3)	-	135	235	mW
Off Hook Power Dissipation	R _L = 600Ω, I _{LONG} = 0, V _{B+} = 12V (Note 3)	-	450	690	mW
Off Hook I _{B+}	R _L = 600Ω, I _{LONG} = 0, T _A = -40°C (Note 3)	-	-	6.0	mA
Off Hook I _{B+}	R _L = 600Ω, I _{LONG} = 0, T _A = 25°C (Note 3)	-	-	5.3	mA
Off Hook I _{B-}	R _L = 600Ω, I _{LONG} = 0 (Note 3)	-	-	39	mA
Off Hook Loop Current	R _L = 1200Ω, I _{LONG} = 0 (Note 3)	-	21	-	mA
Off Hook Loop Current	R _L = 1200Ω, V _{B-} = -42V, I _{LONG} = 0, T _A = 25°C (Note 3)	17.5	-	-	mA
Off Hook Loop Current	R _L = 200Ω, I _{LONG} = 0 (Note 3)	25.5	30	34.5	mA
Fault Currents					
TIP to Ground		-	14	-	mA
RING to Ground		-	47	-	mA
TIP to RING		-	30	-	mA
TIP and RING to Ground		-	47	-	mA
Ring Relay Drive V _{OL}	I _{OL} = 62mA	-	0.2	0.5	V
Ring Relay Driver Off Leakage	V _{RD} = 12V, RC = 1 = HIGH, T _A = 25°C	-	-	100	μA
Ring Trip Detection Period	R _L = 600Ω, T _A = 25°C	-	2	3	Ring Cycles
Switch Hook Detection Threshold	S _H D = V _{OL}	10	-	-	mA
	S _H D = V _{OH}	-	-	5	mA

HC-5502B

Electrical Specifications Unless Otherwise Specified, $V_{B-} = -48V$, $V_{B+} = 12V$ and $5V$, $AG = BG = DG = 0V$, Typical Parameters $T_A = 25^{\circ}C$. Min-Max Parameters are Over Operating Temperature Range **(Continued)**

PARAMETER	TEST CONDITIONS	MIN	TYP	MAX	UNITS
Ground Key Detection Threshold	$\overline{GKD} = V_{OL}$	20	-	-	mA
	$\overline{GKD} = V_{OH}$	-	-	10	mA
Loop Current During Power Denial	$R_L = 200\Omega$	-	± 2	-	mA
Dial Pulse Distortion		0	-	5	ms
Receive Input Impedance	(Note 4)	-	110	-	k Ω
Transmit Output Impedance	(Note 4)	-	10	20	Ω
2-Wire Return Loss	Referenced to $600\Omega + 2.16\mu F$ (Note 4)	-	15.5	-	dB
SRL LO					
ERL					
SRL HI		-	31	-	dB
Longitudinal Balance	$1V_{RMS}$ 200Hz - 3400Hz, (Note 4) IEEE Method $0^{\circ}C \leq T_A \leq 75^{\circ}C$	58	65	-	dB
2-Wire Off Hook					
2-Wire On Hook					
4-Wire Off Hook		50	58	-	dB
Low Frequency Longitudinal Balance	R.E.A. Method, (Note 4) $R_L = 600\Omega$, $0^{\circ}C \leq T_A \leq 75^{\circ}C$	-	-	23	dBrnC
		-	-	-67	dBm0p
Insertion Loss 2-Wire to 4-Wire, 4-Wire to 2-Wire	At 1kHz, 0dBm Input Level, Referenced 600Ω	-	± 0.05	± 0.2	dB
Frequency Response	200 - 3400Hz Referenced to Absolute Loss at 1kHz and 0dBm Signal Level (Note 4)	-	± 0.02	± 0.05	dB
Idle Channel Noise 2-Wire to 4-Wire, 4-Wire to 2-Wire	(Note 4)	-	1	5	dBrnC
		-	-89	-85	dBm0p
Absolute Delay 2-Wire to 4-Wire, 4-Wire to 2-Wire	(Note 4)	-	-	2	μs
Trans Hybrid Loss	Balance Network Set Up for 600Ω Termination at 1kHz	36	40	-	dB
Overload Level 2-Wire to 4-Wire, 4-Wire to 2-Wire	$V_{B+} = 5V$	1.5	-	-	V_{PEAK}
	$V_{B+} = 12V$	1.75	-	-	V_{PEAK}
Level Linearity 2-Wire to 4-Wire, 4-Wire to 2-Wire	At 1kHz, (Note 4) Referenced to 0dBm Level +3 to -40dBm	-	-	± 0.05	dB
	-40 to -50dBm	-	-	± 0.1	dB
	-50 to -55dBm	-	-	± 0.3	dB

HC-5502B

Electrical Specifications Unless Otherwise Specified, $V_{B-} = -48V$, $V_{B+} = 12V$ and $5V$, $AG = BG = DG = 0V$, Typical Parameters $T_A = 25^\circ C$. Min-Max Parameters are Over Operating Temperature Range **(Continued)**

PARAMETER	TEST CONDITIONS	MIN	TYP	MAX	UNITS
Power Supply Rejection Ratio V_{B+} to 2-Wire	30 - 60Hz, $R_L = 600\Omega$, (Note 4)	15	-	-	dB
V_{B+} to Transmit		15	-	-	dB
V_{B-} to 2-Wire		15	-	-	dB
V_{B-} to Transmit		15	-	-	dB
V_{B+} to 2-Wire	200 - 16kHz, $R_L = 600\Omega$	30	-	-	dB
V_{B+} to Transmit		30	-	-	dB
V_{B-} to 2-Wire		30	-	-	dB
V_{B-} to Transmit		30	-	-	dB
Logic Input Current (RS, \overline{RC} , \overline{PD})	$0V \leq V_{IN} \leq 5V$	-	-	± 100	μA
Logic Inputs					
Logic '0' V_{IL}		-	-	0.8	V
Logic '1' V_{IH}		2.0	-	5.5	V
Logic Outputs					
Logic '0' V_{OL}	$I_{LOAD} 800\mu A$, $V_{B+} = 12V$, $5V$	-	0.1	0.5	V
Logic '1' V_{OH}	$I_{LOAD} 80\mu A$, $V_{B+} = 12V$	2.7	5.0	5.5	V
	$I_{LOAD} 40\mu A$, $V_{B+} = 5V$	2.7	-	5.0	V

Uncommitted Op Amp Specifications

PARAMETER	TEST CONDITIONS	MIN	TYP	MAX	UNITS
Input Offset Voltage		-	± 5	-	mV
Input Offset Current		-	± 10	-	nA
Input Bias Current		-	20	-	nA
Differential Input Resistance	(Note 4)	-	1	-	$M\Omega$
Output Voltage Swing	$R_L = 10k\Omega$, $V_{B+} = 12V$	-	± 6.2	± 6.6	V_{PEAK}
	$R_L = 10k\Omega$, $V_{B+} = 5V$	-	± 3	-	V_{PEAK}
Output Resistance	$A_{VCL} = 1$ (Note 4)	-	10	-	Ω
Small Signal GBW	(Note 4)	-	1	-	MHz

NOTES:

3. I_{LONG} = Longitudinal Current.
4. These parameters are controlled by design or process parameters and are not directly tested. These parameters are characterized upon initial design release, upon design changes which would affect these characteristics, and at intervals to assure product quality and specification compliance.

Pin Descriptions

28 PIN PLCC	24 PIN DIP	SYMBOL	DESCRIPTION
2	1	TIP	An analog input connected to the TIP (more positive) side of the subscriber loop through a 150Ω feed resistor and a ring relay contact. Functions with the Ring terminal to receive voice signals from the telephone and for loop monitoring process.
3	2	RING	An analog input connected to the RING (more negative) side of the subscriber loop through a 150Ω feed resistor and a ring relay contact. Functions with the Tip terminal to receive voice signals from the telephone and for loop monitoring purposes.
4	3	V _{B+}	Positive Voltage Source - Most positive supply. V _{B+} is typically 12V or 5V.
5	4	C ₁	Capacitor #1 - Optional Capacitor used to improve power supply rejection. This pin should be left open if unused.
6	5	C ₃	Capacitor #3 - An external capacitor to be connected between this terminal and analog ground. Required for proper operation of the loop current limiting function, and for filtering V _{B-} supply. Typical value is 0.3μF, 30V.
7	6	DG (Note 5)	Digital Ground - To be connected to zero potential and serves as a reference for all digital inputs and outputs on the SLIC.
9	7	RS	Ring Synchronization Input - A TTL - compatible clock input. The clock should be arranged such that a positive transition occurs on the negative going zero crossing of the ring voltage source, ensuring that the ring relay is activated and deactivated when the instantaneous ring voltage is near zero. If synchronization is not required, tie to 5V.
10	8	\overline{RD}	Relay Driver - A low active open collector logic output. When enabled, the external ring relay is energized.
11	9	TF	Tip Feed - A low impedance analog output connected to the TIP terminal through a 150Ω feed resistor. Functions with the RF terminal to provide loop current, feed voice signals to the telephone set, and sink longitudinal current.
12	10	RF	Ring Feed - A low impedance analog output connected to the RING terminal through a 150Ω feed resistor. Functions with the TF terminal to provide loop current, feed voice signal to the telephone set, and sink longitudinal current.
13	11	V _{B-}	Negative Voltage Source - Most negative supply. V _{B-} is typically -48V with an operational range of -42V to -58V. Frequently referred to as "battery".
14	12	BG (Note 1)	Battery Ground - To be connected to zero potential. All loop current and some quiescent current flows into this ground terminal.
16	13	\overline{SHD}	Switch Hook Detection - A low active LS TTL - compatible logic output. This output is enabled for loop currents exceeding 10mA and disabled for loop currents less than 5mA.
17	14	\overline{GKD}	Ground Key Detection - A low active LS TTL - compatible logic output. This output is enabled if the DC current into the ring lead exceeds the DC current out of the tip lead by more than 20mA, and disabled if this current difference is less than 10mA.
18	15	\overline{PD}	Power Denial - A low active TTL - Compatible logic input. When enabled the switch hook detect (\overline{SHD}) and ground key detect (\overline{GKD}) are not necessarily valid, and the relay driver (\overline{RD}) output is disabled.
19	16	\overline{RC}	Ring Command - A low active TTL - Compatible logic input. When enabled, the relay driver (\overline{RD}) output goes low on the next rising edge of the ring sync (\overline{RS}) input, as long as the SLIC is not in the power denial state ($\overline{PD} = 0$) or the subscriber is not already off-hook ($\overline{SHD} = 0$).
20	17	C ₂	Capacitor #2 - An external capacitor to be connected between this terminal and digital ground. Prevents false ground key indications from occurring during ring trip detection. Typical value is 0.15μF, 10V. This capacitor is not used if ground key function is not required.
21	18	OUT	The analog output of the spare operational amplifier.
23	19	-IN	The inverting analog input of the spare operational amplifier.
24	20	+IN	The non-inverting analog input of the spare operational amplifier.

Pin Descriptions (Continued)

28 PIN PLCC	24 PIN DIP	SYMBOL	DESCRIPTION
25	21	RX	Receive Input, 4-Wire Side - A high impedance analog input which is internally biased. Capacitive coupling to this input is required. AC signals appearing at this input differentially drive the Tip feed and Ring feed amplifiers, which in turn drive tip and ring through 300Ω of feed resistance on each side of the line.
26	22	C ₄	Capacitor #4 - An external capacitor to be connected between this terminal and analog ground. This capacitor prevents false ground key indication and false ring trip detection from occurring when longitudinal currents are induced onto the subscriber loop from nearby power lines and other noise sources. This capacitor is also required for the proper operation of ring trip detection. Typical value is 0.5μF to 1.0μF, 20V. This capacitor should be nonpolarized.
27	23	AG (Note 5)	Analog Ground - To be connected to zero potential and serves as a reference for the transmit output (TX) and receive input (RX) terminals.
28	24	TX	Transmit Output, 4-Wire Side - A low impedance analog output which represents the differential voltage across Tip and Ring. Transhybrid balancing must be performed (using the SLIC microcircuit's spare op amp) beyond this output to completely implement two to four wire conversion. This output is unbalanced and referenced to analog ground. Since the DC level of this output varies with loop current, capacitive coupling to the next stage is essential.
1, 8, 5, 22		NC	No internal connection.

NOTE:

- All grounds (AG, BG, and DG) must be applied before V_{B+} or V_{B-}. Failure to do so may result in premature failure of the part. If a user wishes to run separate grounds off a line card, the AG must be applied first.

Functional Diagram

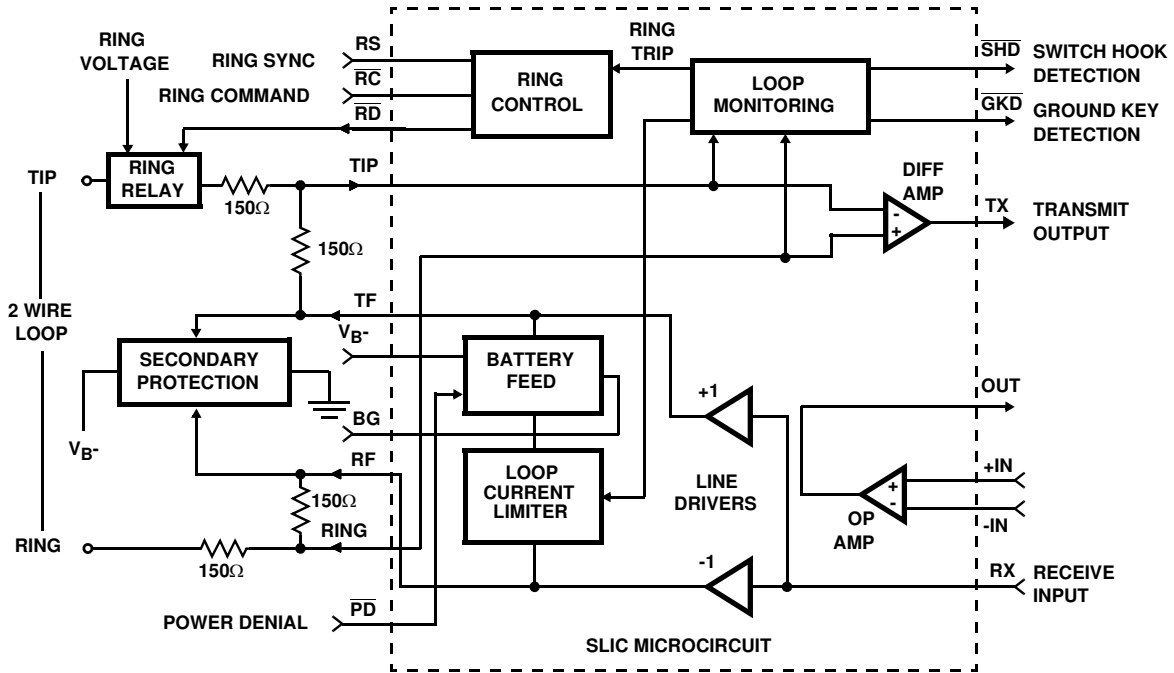

HC-5502B

Schematic Diagram

HC-5502B

Pin Numbers for DIP Package

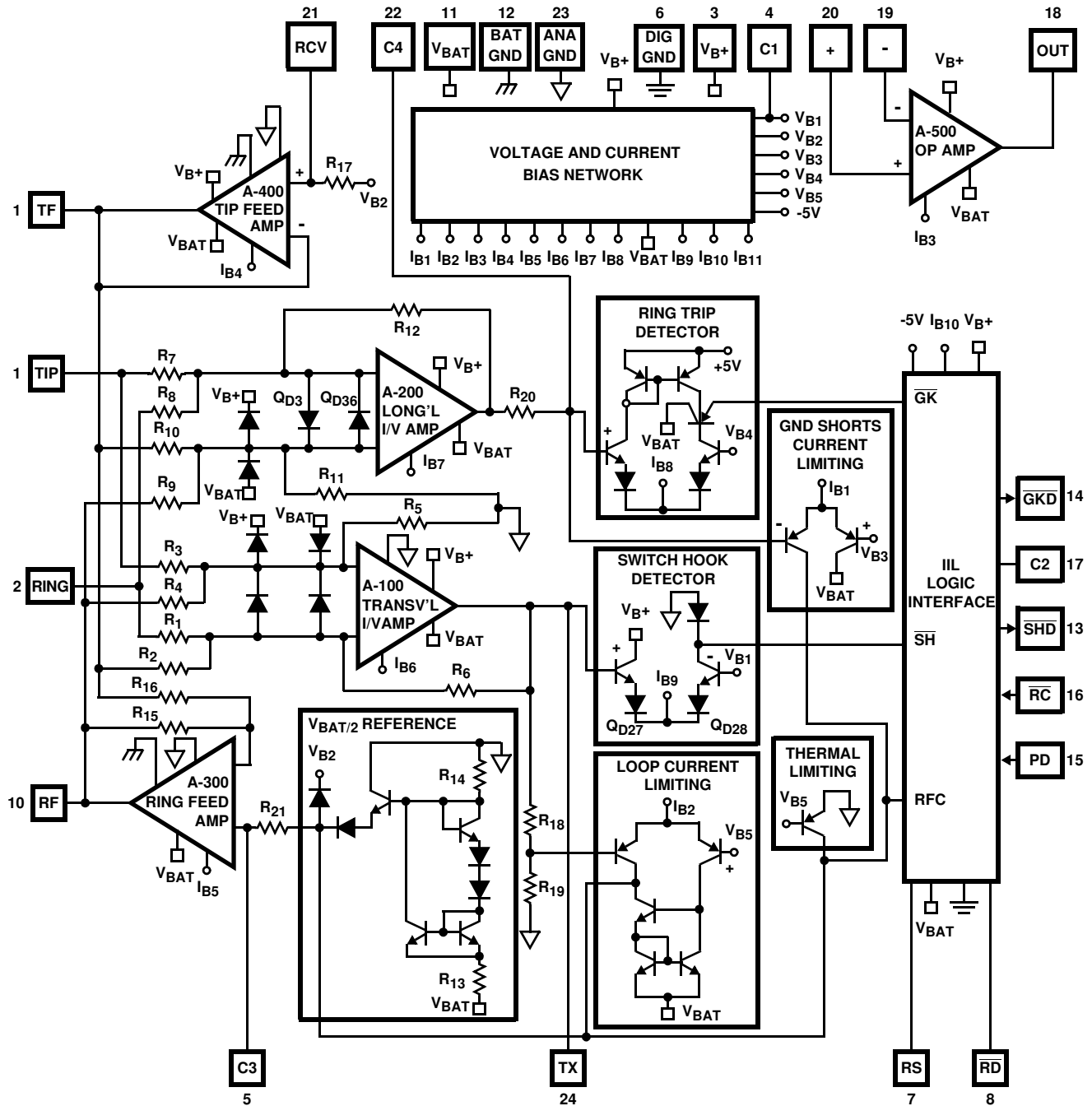

Logic Diagram

HC-5502B LOGIC GATE SCHEMATIC

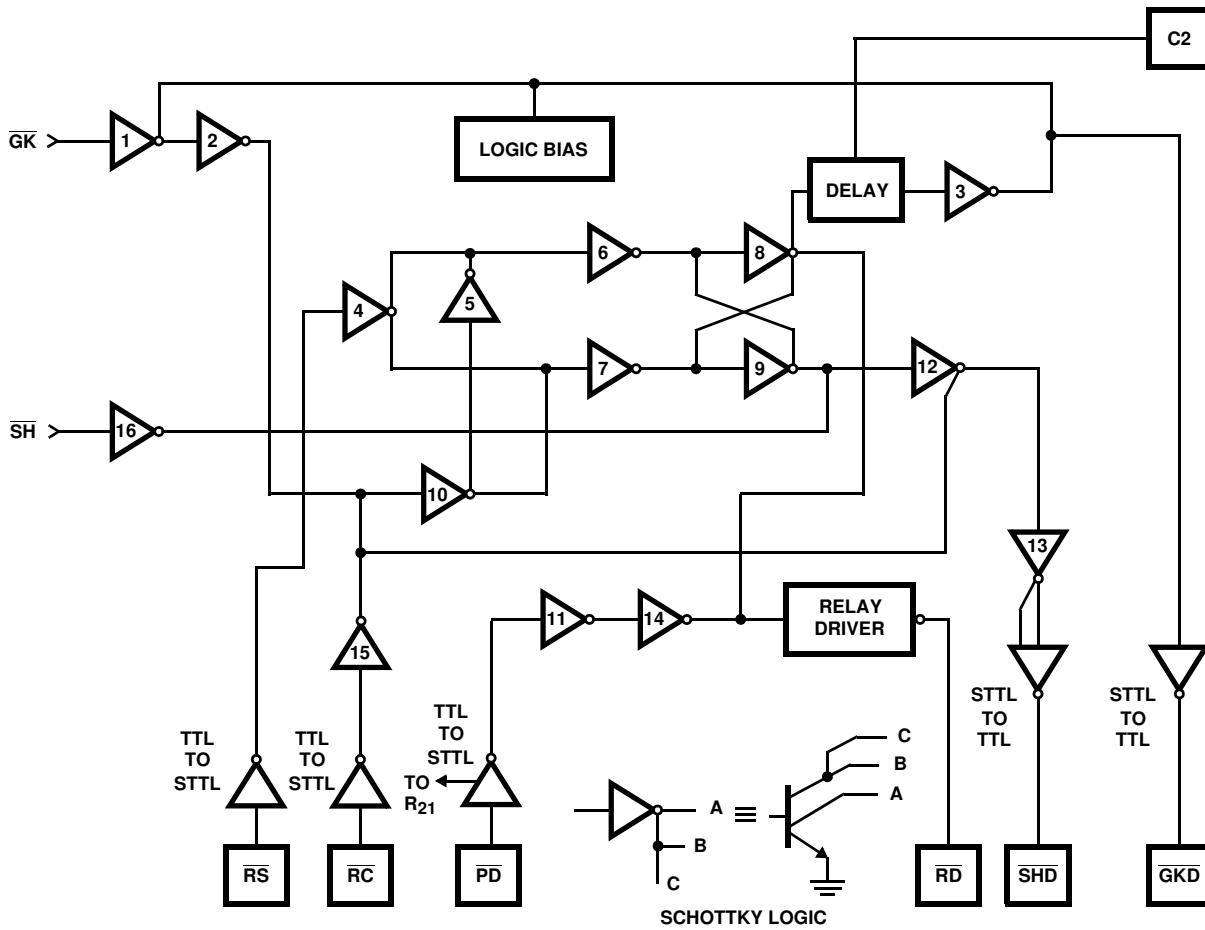

Overvoltage Protection and Longitudinal Current Protection

The SLIC device, in conjunction with an external protection bridge, will withstand high voltage lightning surges and power line crosses.

High voltage surge conditions are as specified in Table 1.

The SLIC will withstand longitudinal currents up to a maximum of 30mARMS, 15mARMS per leg, without any performance degradation.

TABLE 1.

PARAMETER	TEST CONDITION	PERFORMANCE (MAX)	UNITS
Longitudinal Surge	10 μ s Rise/	\pm 1000 (Plastic)	V _{PEAK}
	1000 μ s Fall	\pm 500 (Ceramic)	V _{PEAK}
Metallic Surge	10 μ s Rise/	\pm 1000 (Plastic)	V _{PEAK}
	1000 μ s Fall	\pm 500 (Ceramic)	V _{PEAK}
T/GND	10 μ s Rise/	\pm 1000 (Plastic)	V _{PEAK}
R/GND	1000 μ s Fall	\pm 500 (Ceramic)	V _{PEAK}
50/60Hz Current			
T/GND	11 Cycles	700 (Plastic)	V _{RMS}
R/GND	Limited to 10A _{RMS}	350 (Ceramic)	V _{RMS}

Applications Diagram

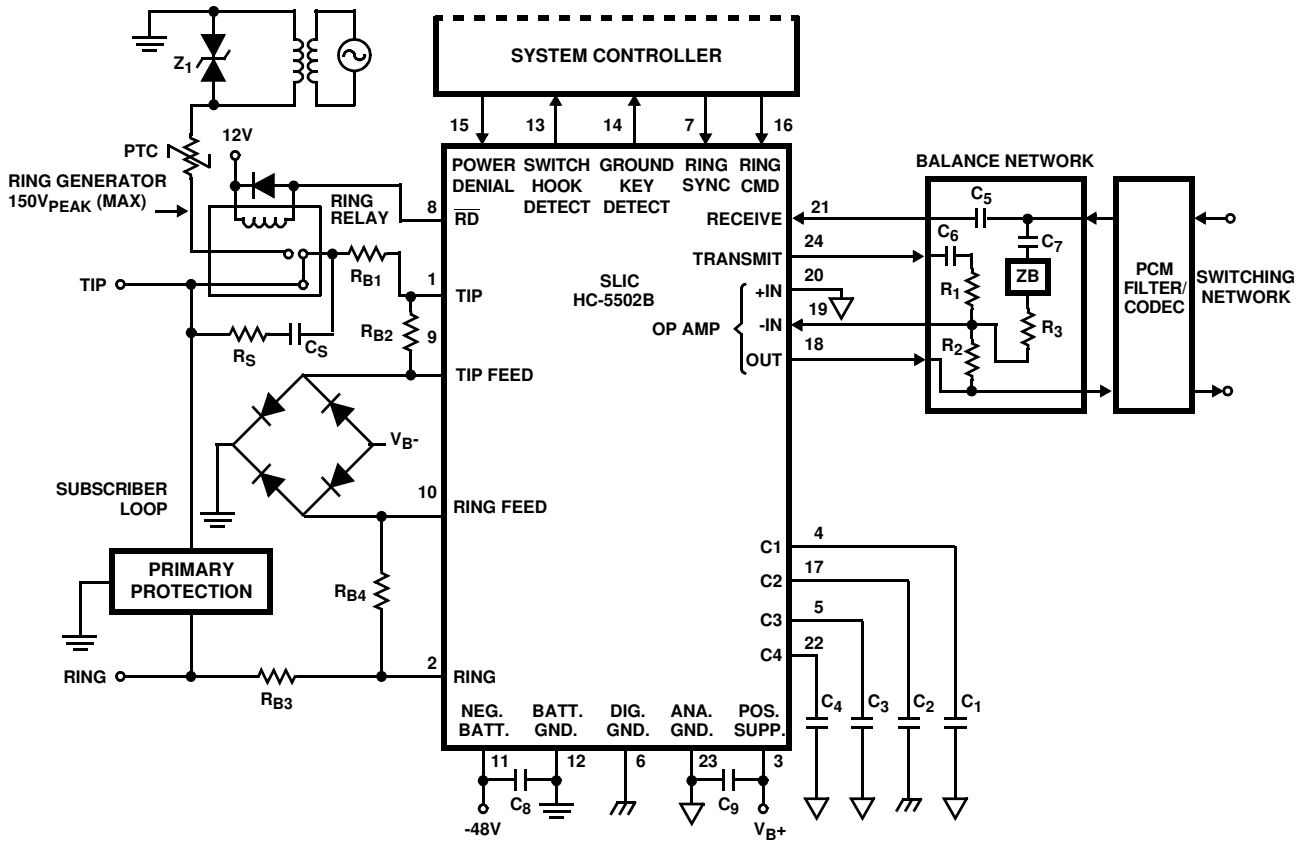

FIGURE 1. TYPICAL LINE CIRCUIT APPLICATION WITH THE MONOLITHIC SLIC

Typical Component Values

C₁ = 0.5μF (Note 6).

C₂ = 0.15μF, 10V.

C₃ = 0.3μF, 30V.

C₄ = 0.5μF to 1.0μF, 10%, 20V (Should be nonpolarized).

C₅ = 0.5μF, 20V.

C₆ = C₇ = 0.5μF (10% Match Required) (Note 7), 20V.

C₈ = 0.01μF, 100V.

C₉ = 0.01μF, 20V, ±20%.

R₁ = R₂ = R₃ = 100kΩ (0.1% Match Required, 1% absolute value), ZB = 0 for 600Ω Terminations (Note 7).

R_{B1} = R_{B2} = R_{B3} = R_{B4} = 150Ω (0.1% Match Required, 1% absolute value).

R_S = 1kΩ, C_S = 0.1μF, 200V typically, depending on V_{RING} and line length.

Z₁ = 150V to 200V transient protection. PTC used as ring generator ballast.

NOTES:

6. C₁ is an optional capacitor used to improve V_{B+} supply rejection. This pin must be left open if unused.
7. To obtain the specified transhybrid loss it is necessary for the three legs of the balance network, C₆-R₁ and R₂ and C₇-ZB-R₃, to match in impedance to within 0.3%. Thus, if C₆ and C₇ are 1μF each, a 20% match is adequate. It should be noted that the transmit output to C₆ sees a -22V step when the loop is closed. Too large a value for C₆ may produce an excessively long transient at the op amp output to the PCM Filter/CODEC.
A 0.5μF and 100kΩ gives a time constant of 50ms. The uncommitted op amp output is internally clamped to stay within ±6.6V and is current limited.
8. Secondary protection diode bridge recommended is a 2A, 200V type.
9. All grounds (AG, BG, and DG) must be applied before V_{B+} or V_{B-}. Failure to do so may result in premature failure of the part. If a user wishes to run separate grounds off a line card, the AG must be applied first.
10. Pin numbers given for DIP package.

Dual-In-Line Plastic Packages (PDIP)

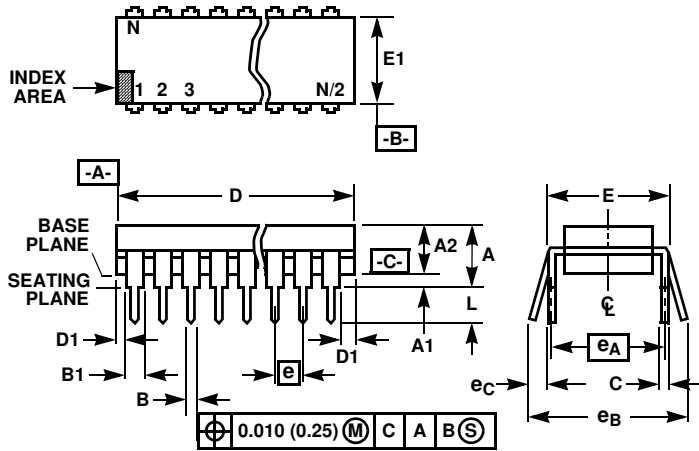

NOTES:

1. Controlling Dimensions: INCH. In case of conflict between English and Metric dimensions, the inch dimensions control.
2. Dimensioning and tolerancing per ANSI Y14.5M-1982.
3. Symbols are defined in the "MO Series Symbol List" in Section 2.2 of Publication No. 95.
4. Dimensions A, A1 and L are measured with the package seated in JEDEC seating plane gauge GS-3.
5. D, D1, and E1 dimensions do not include mold flash or protrusions. Mold flash or protrusions shall not exceed 0.010 inch (0.25mm).
6. E and e_A are measured with the leads constrained to be perpendicular to datum $-C-$.
7. e_B and e_C are measured at the lead tips with the leads unconstrained. e_C must be zero or greater.
8. B1 maximum dimensions do not include dambar protrusions. Dambar protrusions shall not exceed 0.010 inch (0.25mm).
9. N is the maximum number of terminal positions.
10. Corner leads (1, N, N/2 and N/2 + 1) for E8.3, E16.3, E18.3, E28.3, E42.6 will have a B1 dimension of 0.030 - 0.045 inch (0.76 - 1.14mm).

E24.6 (JEDEC MS-011-AA ISSUE B)
24 LEAD DUAL-IN-LINE PLASTIC PACKAGE

SYMBOL	INCHES		MILLIMETERS		NOTES
	MIN	MAX	MIN	MAX	
A	-	0.250	-	6.35	4
A1	0.015	-	0.39	-	4
A2	0.125	0.195	3.18	4.95	-
B	0.014	0.022	0.356	0.558	-
B1	0.030	0.070	0.77	1.77	8
C	0.008	0.015	0.204	0.381	-
D	1.150	1.290	29.3	32.7	5
D1	0.005	-	0.13	-	5
E	0.600	0.625	15.24	15.87	6
E1	0.485	0.580	12.32	14.73	5
e	0.100 BSC		2.54 BSC		-
e_A	0.600 BSC		15.24 BSC		6
e_B	-	0.700	-	17.78	7
L	0.115	0.200	2.93	5.08	4
N	24		24		9

Rev. 0 12/93

Plastic Leaded Chip Carrier Packages (PLCC)

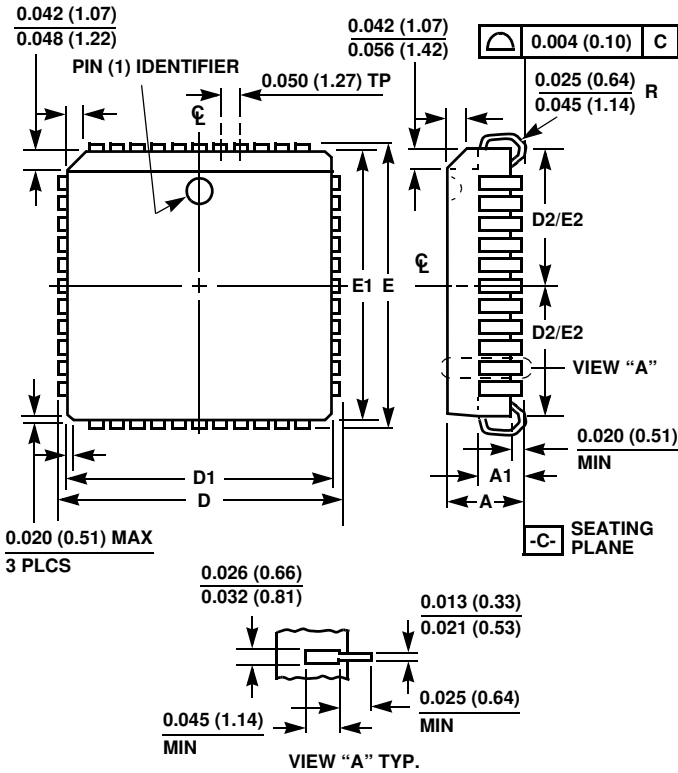

N28.45 (JEDEC MS-018AB ISSUE A)
28 LEAD PLASTIC LEADED CHIP CARRIER PACKAGE

SYMBOL	INCHES		MILLIMETERS		NOTES
	MIN	MAX	MIN	MAX	
A	0.165	0.180	4.20	4.57	-
A1	0.090	0.120	2.29	3.04	-
D	0.485	0.495	12.32	12.57	-
D1	0.450	0.456	11.43	11.58	3
D2	0.191	0.219	4.86	5.56	4, 5
E	0.485	0.495	12.32	12.57	-
E1	0.450	0.456	11.43	11.58	3
E2	0.191	0.219	4.86	5.56	4, 5
N	28		28		6

Rev. 2 11/97

NOTES:

- Controlling dimension: INCH. Converted millimeter dimensions are not necessarily exact.
- Dimensions and tolerancing per ANSI Y14.5M-1982.
- Dimensions D1 and E1 do not include mold protrusions. Allowable mold protrusion is 0.010 inch (0.25mm) per side. Dimensions D1 and E1 include mold mismatch and are measured at the extreme material condition at the body parting line.
- To be measured at seating plane -C- contact point.
- Centerline to be determined where center leads exit plastic body.
- "N" is the number of terminal positions.

All Intersil U.S. products are manufactured, assembled and tested utilizing ISO9000 quality systems.
Intersil Corporation's quality certifications can be viewed at www.intersil.com/design/quality

Intersil products are sold by description only. Intersil Corporation reserves the right to make changes in circuit design, software and/or specifications at any time without notice. Accordingly, the reader is cautioned to verify that data sheets are current before placing orders. Information furnished by Intersil is believed to be accurate and reliable. However, no responsibility is assumed by Intersil or its subsidiaries for its use; nor for any infringements of patents or other rights of third parties which may result from its use. No license is granted by implication or otherwise under any patent or patent rights of Intersil or its subsidiaries.

For information regarding Intersil Corporation and its products, see www.intersil.com