

RF CHARACTERISTICS

Frequency range : **0 - 26.5 GHz**
Impedance : **50 Ohms**

Frequency (GHz)	DC - 3	3 - 8	8 - 12.4	12.4 - 18	18 - 26.5
VSWR max	1.20	1.30	1.40	1.50	1.70
Insertion loss max	0.20 dB	0.30 dB	0.40 dB	0.50 dB	0.70 dB
Isolation min	80 dB	70 dB	65 dB	60 dB	50 dB
Average power (*)	240 W	150 W	120 W	100 W	40 W

ELECTRICAL CHARACTERISTICS

Actuator : **LATCHING**
Nominal current ** : **125 mA**
Actuator voltage (Vcc) : **28V (24 to 30V) / POSITIVE COMMON**
Terminals : **solder pins (250°C max. / 30 sec.)**
Self cut-off time : **40 ms < CT < 120 ms**

MECHANICAL CHARACTERISTICS

Connectors : **SMA female per MIL-C 39012**
Life : **2.5 million cycles**
Switching Time*** : **< 15 ms**
Construction : **Splashproof**
Weight : **< 100 g**

ENVIRONMENTAL CHARACTERISTICS

Operating temperature range : **-40°C to +85°C**
Storage temperature range : **-55°C to +85°C**

(* Average power at 25°C per RF Path)

(** At 25° C ±10%)

(*** Nominal voltage ; 25° C)



PAGE 2/2

ISSUE 22-03-22

SERIE : DPDT

PART NUMBER : R577F53010

DRAWING

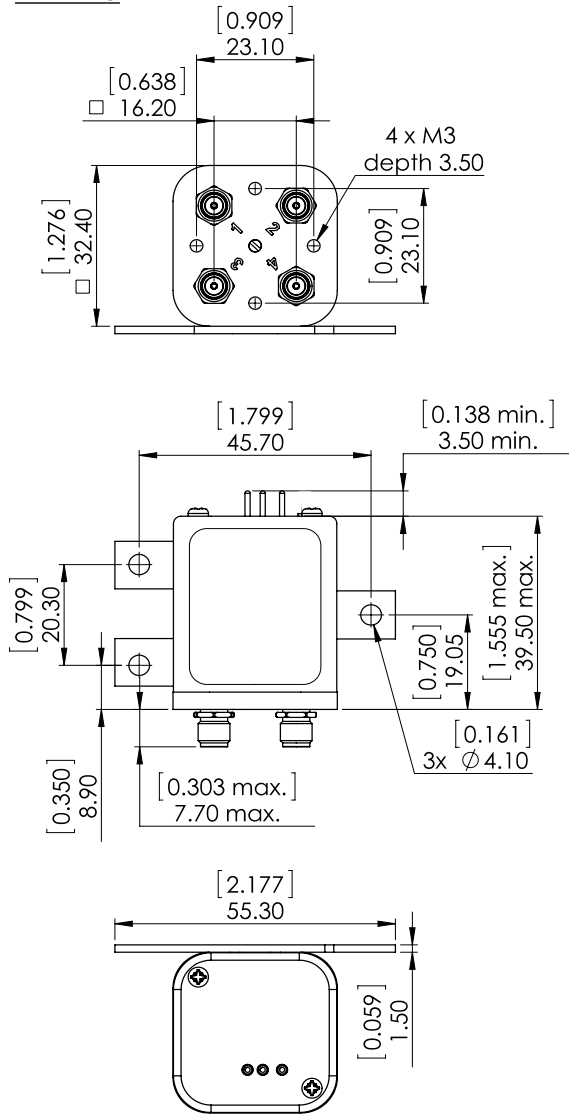

General tolerances : ±0,5 mm [0,02 in]

SCHEMATIC DIAGRAM

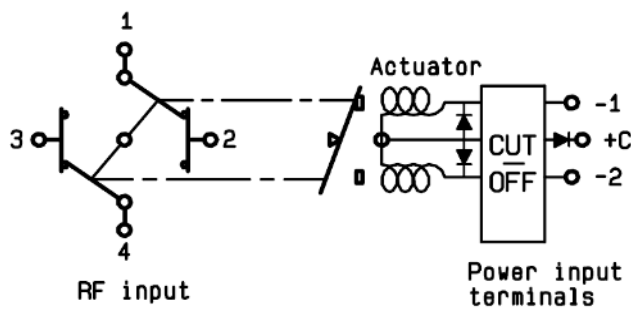

Voltage	RF Continuity
+C -1	1 ↔ 3 / 2 ↔ 4
+C -2	1 ↔ 2 / 3 ↔ 4



LABEL

-1 -2 +C

RADIALL®
R577F53010
0 - 26.5 GHz
Un : 28V
Lot : _____