

REVISIONS			
LTR	DESCRIPTION	DATE	APPROVED
A	REVISED PER E.C.N. T-18330	93/JUN/29	ZET
B	REVISED PER E.C.N. T-21528	7/1/97	ZET

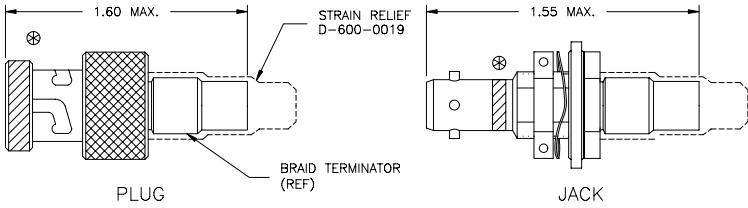

MAX LENGTH AFTER TERMINATION

CONNECTOR	INTERFACE	COLOR CODE
D-621-X633	PLUG "A" PER FIGURE 1	RED
D-621-X634	JACK "A" PER FIGURE 2	RED
D-621-X635	PLUG "B" PER FIGURE 3	WHITE
D-621-X636	JACK "B" PER FIGURE 4	WHITE
D-621-X637	PLUG "C" PER FIGURE 5	GREEN
D-621-X638	JACK "C" PER FIGURE 6	GREEN
D-621-X639	PLUG "D" PER FIGURE 7	N/A
D-621-X640	JACK "D" PER FIGURE 8	N/A

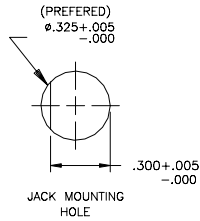

DWG No: EXAMPLE X633

0633 .148 MAX. CABLE DIA ACCOMODATION
BRAID TERMINATOR D-600-0055
"E" = .220, "F" = .149

1633 .180 MAX. CABLE DIA ACCOMODATION
BRAID TERMINATOR D-600-0056
"E" = .242, "F" = .181

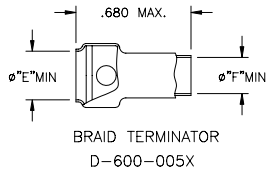

SPECIFICATION CONTROL DRAWING

If this document is printed it becomes uncontrolled.
Check with the web for latest revision.

UNLESS OTHERWISE SPECIFIED DIMENSIONS ARE IN INCHES. METRIC DIMENSIONS ARE IN BRACKETS.	REDRAWN	Z.E.T.	6/30/97	<i>Raychem</i> RAYCHEM CORPORATION 300 CONSTITUTION DRIVE MENLO PARK, CALIFORNIA 94025
	CHECKED			
	APPROVED	M.HIGGY	7/1/97	
	APPROVED			
DECIMALS .XXX ± [— mm] .XX ± [— mm]	CAD NAME T21528g			TITLE CONNECTOR, TRAXIAL, SUBMINIATURE, BAYONET COUPLED
ANGLES .X ± [—]	THIRD ANGLE PROJECTION			SIZE A
WEIGHT — lbs [— g]		CODE IDENT. NO. 06090	DWG. NO. D-621-X633/X640	REV B
DO NOT SCALE THIS DRAWING			SHEET 1 OF 3	

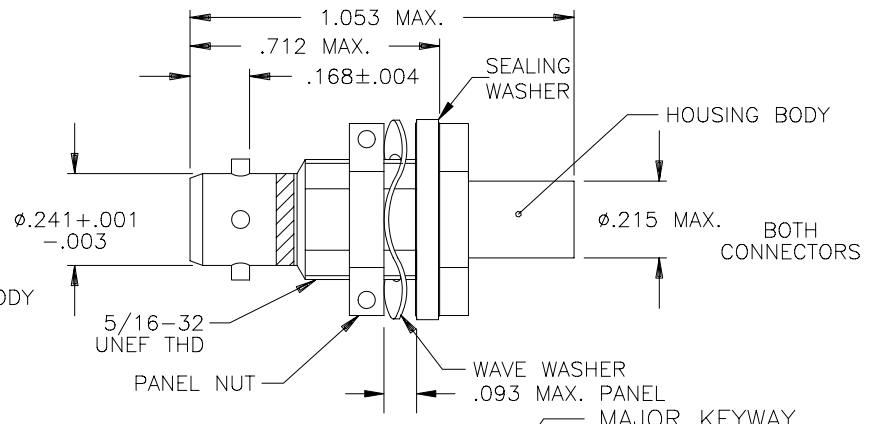
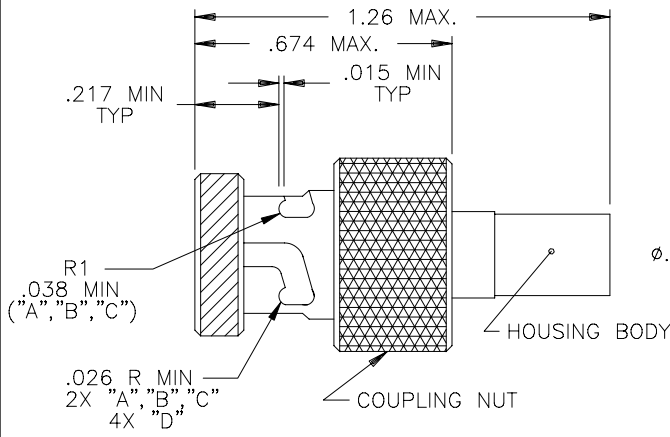

INTERFACE

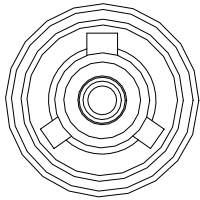

FIGURE 1

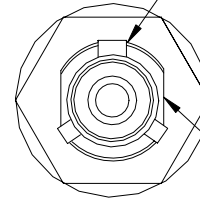

FIGURE 2

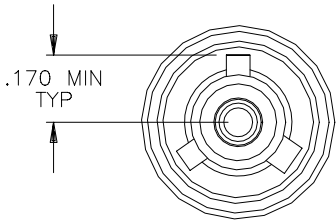

FIGURE 3

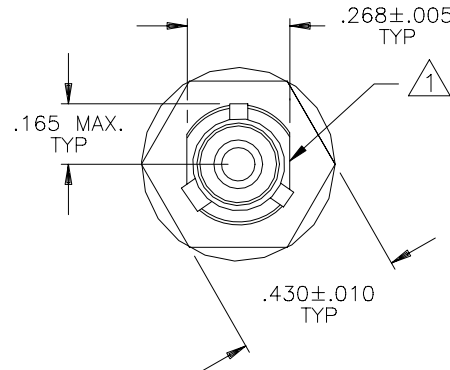

FIGURE 4

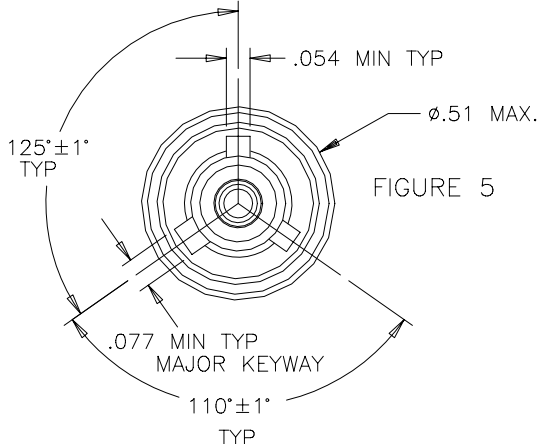

FIGURE 5

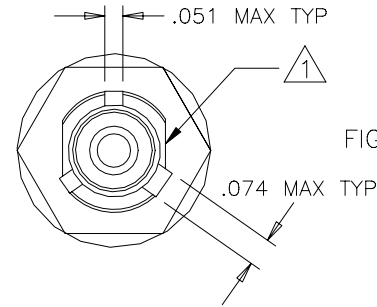

FIGURE 6

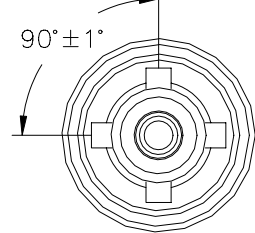

FIGURE 7

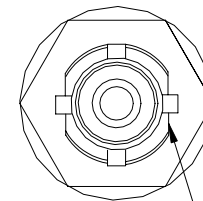

FIGURE 8

If this document is printed it becomes uncontrolled.
Check with the web for latest revision.

NOTES: MAJOR KEY ORIENTATION WITH RESPECT TO FLATS IS NOT CONTROLLED.

CAD NAME: T21528b	REDRAWN	Z.E.T.	7/1/97	SIZE A	CODE IDENT. NO. 06090	DWG. NO. D-621-X633/X640	REV B
	ISSUED			DO NOT SCALE THIS DRAWING		SHEET 2 OF 3	

SPECIFICATIONS

SEE SHEET 1 FOR REVISION

1.0 MATERIALS AND FINISHES

- 1.1 HOUSING BODY: BeCu ALLOY, C173000 PER ASTM B196, TB00 OR TD04, TIN PLATED PER MIL-T-10727, OVER NICKEL PER ASTM B 656.
- 1.1.1 INSULATION (MIP): POLYETHERSULFONE.
- 1.2 COUPLING NUT (PLUG): BeCu ALLOY, ASTM B196, TB00 OR TD04, TIN PLATED PER MIL-T-10727, OVER NICKEL PER ASTM B 656.
- 1.2.1 INTERFACIAL SEAL: SILICONE RUBBER.
- 1.3 PANEL NUT (JACK): BRASS ALLOY PER ASTM B16, TIN PLATED PER MIL-T-10727, OVER NICKEL PER ASTM B 656.
- 1.4 WAVE WASHER (JACK): BeCu PER ASTM B194, TIN PLATED PER MIL-T-10727, OVER NICKEL PER ASTM B 656.
- 1.5 SEALING WASHER: (JACK) SILICONE RUBBER (ASM - 3304), STAINLESS STEEL PER MIL-S-5059, PASSIVATED PER QQ-P-35.

1.6 BRAID TERMINATOR

- 1.6.1 BODY: BRASS ALLOY PER ASTM B16, TIN-LEAD PLATED PER MIL-P-81728.
- 1.6.2 SOLDER PREFORM: Sn63 PER QQ-S-571.
- 1.6.3 INSULATION SLEEVE: POLYVINYLIDENE FLUORIDE.
- 1.6.4 SEALING INSERT: FLUOROCARBON BASED THERMOPLASTIC.
- 1.7 STRAIN RELIEF: WHITE RNF-100 WITH ADHESIVE

2.0 PERFORMANCE CAPABILITIES

- 2.1 QUALIFIED TO RAYCHEM SPECIFICATION D-6025.
- 2.2 GENERAL CHARACTERISTICS.
 - 2.2.1 OPERATING TEMPERATURE: -65°C TO 125°C
 - 2.2.2 INSULATION RESISTANCE: GREATER THAN 5K MEG
 - 2.2.3 DIELECTRIC STRENGTH: 900 VAC @ 60 Hz
 - 2.2.4 CURRENT RATING: 3 AMPS MAX.
 - 2.2.5 SALT SPRAY CORROSION RESISTANCE: 500 HOURS

3.0 CONTACT/CABLE CONSTRUCTIONS

3.1 THE CONNECTOR WILL ACCOMMODATE THE FOLLOWING RAYCHEM CONTACTS:

<u>PART No.</u>	<u>CABLE TYPE</u>	<u>CONTACT DESCRIPTION</u>
D-602-44	TRIAxIAL	SHIELDED PIN
D-602-45	TRIAxIAL	SHIELDED SOCKET
D-602-0126	TWINAXIAL	SHIELDED PIN, TWISTED PAIR
D-602-0127	TWINAXIAL	SHIELDED SOCKET, TWISTED PAIR
D-610-09	COAXIAL	POWER, PIN
D-610-10	COAXIAL	POWER, SOCKET

4.0 TERMINATION PROCEDURE: RAYCHEM ES-61162

**If this document is printed it becomes uncontrolled.
Check with the web for latest revision.**

CAD NAME: T21528c	REDRAWN	Z.E.T.	7/1/97	SIZE A	CODE IDENT. NO. 06090	DWG. NO. D-621-X633/X640	REV B
	ISSUED			DO NOT SCALE THIS DRAWING		SHEET 3 OF 3	