

- ① HOUSING MATERIAL: GLASS FILLED POLYESTER PER AMP 100-457. COLOR: BLUE (26682-2)
- ② NUMBERS MARKED ON MATING FACE. LINES INDICATING EVERY FIVE CAVITIES MARKED ON MATING FACE. (LINES OPTIONAL)
- ③ CONTACT SHOWN FOR REFERENCE ONLY AND MUST BE PURCHASED SEPARATELY. PART NUMBER 531215 FOR #28 TO #32 AWG WITH .000050 GOLD INLAY, TIN-LEAD IN WIRE BARREL, PART NUMBER 531216 FOR #22 TO #26 AWG WITH SAME FINISH.
- ④ AMP, PART NUMBER AND DATE CODE INK STAMPED OR LASER MARKED ON THIS SURFACE, COLOR, WHITE

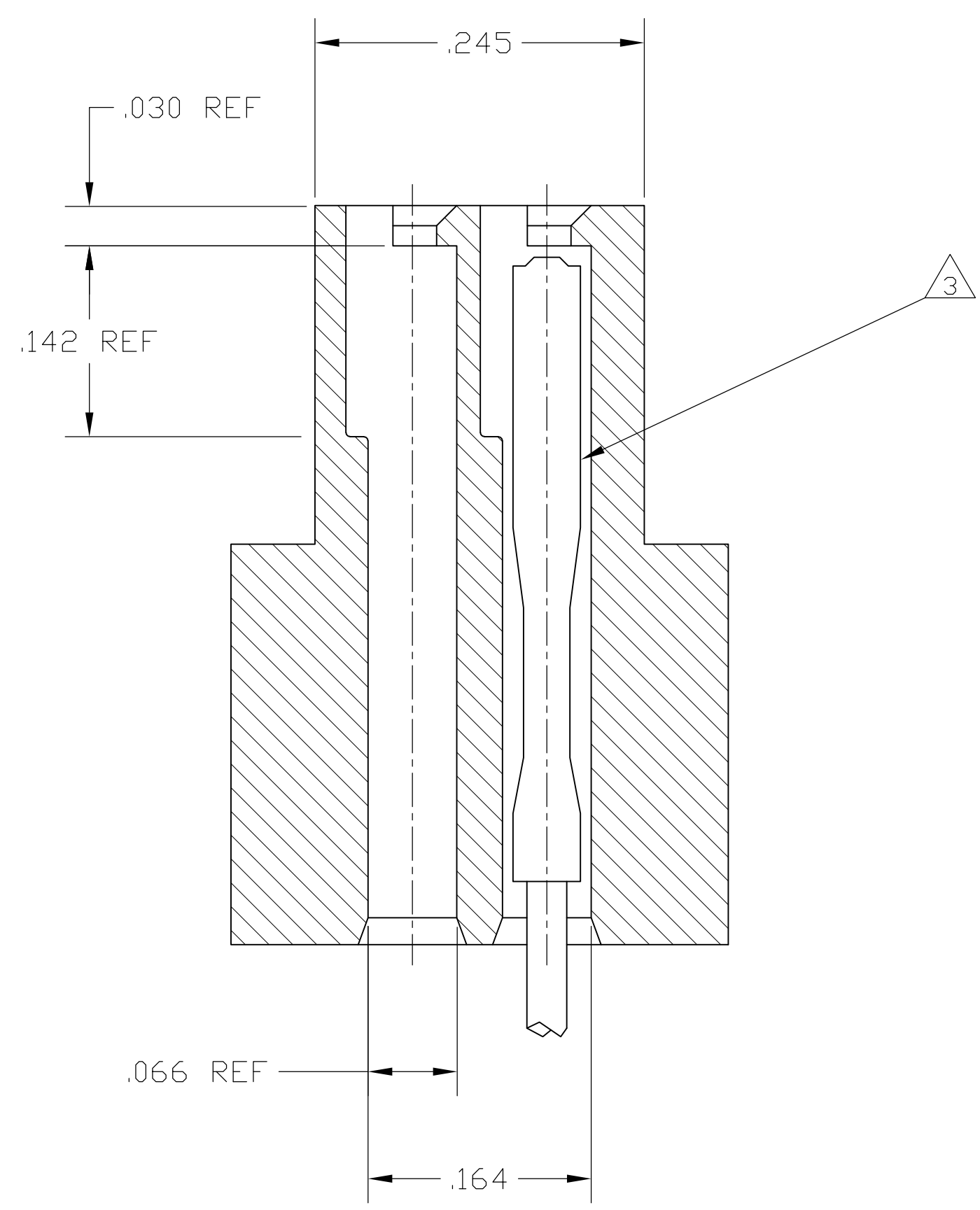
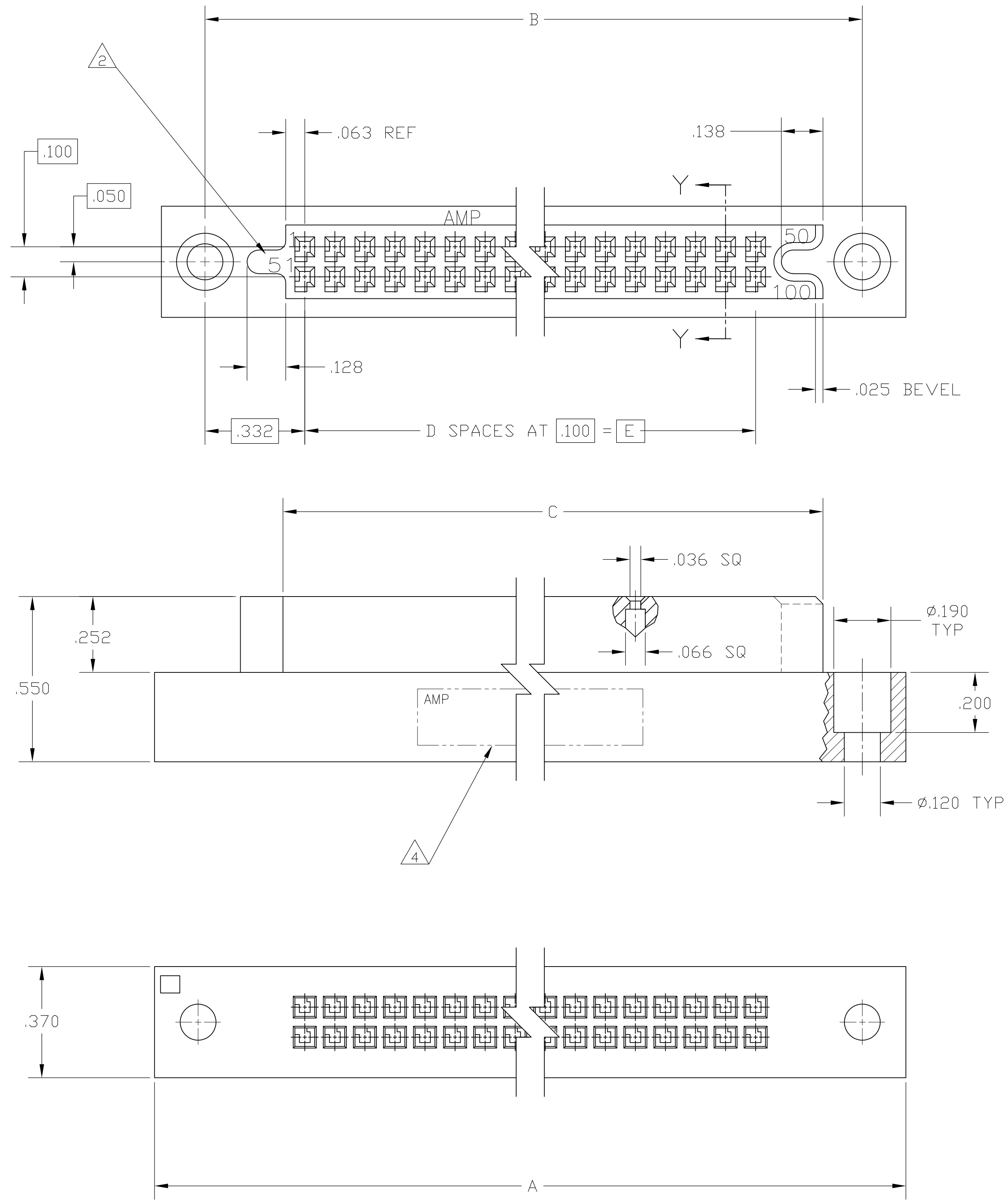

CAVITY IDENTIFICATION	E	D	C	B	A	NO OF POSN	PART NUMBER
56 - 55	5.400 [137.16]	54	5.665 [143.89]	6.065 [154.05]	6.355 [161.42]	110	1-531840-7
51 - 50	4.900 [124.46]	49	5.165 [131.19]	5.565 [141.35]	5.855 [148.72]	100	1-531840-5
46 - 45	4.400 [111.76]	44	4.665 [118.49]	5.065 [128.65]	5.355 [136.02]	90	1-531840-3
41 - 40	3.900 [99.06]	39	4.165 [105.79]	4.565 [115.95]	4.855 [123.32]	80	1-531840-1
36 - 35	3.400 [86.36]	34	3.665 [93.09]	4.065 [103.25]	4.355 [110.62]	70	531840-9
31 - 30	2.900 [73.66]	29	3.165 [80.39]	3.565 [90.55]	3.855 [97.92]	60	531840-7
26 - 25	2.400 [60.96]	24	2.665 [67.69]	3.065 [77.85]	3.355 [85.22]	50	531840-5
21 - 20	1.900 [48.26]	19	2.165 [54.99]	2.565 [65.15]	2.855 [72.52]	40	531840-3
16 - 15	1.400 [35.56]	14	1.665 [42.29]	2.065 [52.45]	2.355 [59.82]	30	531840-1

THIS DRAWING IS A CONTROLLED DOCUMENT.

APPROVED: T. THOMPSON 01JUN98
 CHK: D. GUTTER 01JUN98
 PRODUCT SPEC: D. GUTTER 01JUN98

NAME: RECEPTACLE HOUSING, BOX CONNECTOR
 .100 CENTERS FOR TANDEM SPRING

SIZE: A1
 CAGE CODE: 00779
 DRAWING NO: 531840

RESTRICTED TO: CUSTOMER DRAWING

SCALE: 4:1 SHEET: 1 OF 1 REV: C

THIS DRAWING IS UNPUBLISHED. RELEASED FOR PUBLICATION .19
 BY AMP INCORPORATED. ALL RIGHTS RESERVED.

LOC	DIST	REVISIONS					
DF	FO	P	LTR	DESCRIPTION	DATE	DWN	APVD
		-		SEE SHEET 1	-	-	-

- ① HOUSING MATERIAL: GLASS FILLED POLYESTER PER AMP 100-457. COLOR: BLUE (26682-2)
- ② NUMBERS MARKED ON MATING FACE. LINES INDICATING EVERY FIVE CAVITIES MARKED ON MATING FACE. (LINES OPTIONAL)
- ③ CONTACT SHOWN FOR REFERENCE ONLY AND MUST BE PURCHASED SEPARATELY. PART NUMBER 531215 FOR #28 TO #32 AWG WITH .000050 GOLD INLAY, TIN-LEAD IN WIRE BARREL, PART NUMBER 531216 FOR #22 TO #26 AWG WITH SAME FINISH.
- ④ AMP, PART NUMBER AND DATE CODE INK STAMPED WHITE THIS SURFACE.

1 - 55	5.400 [137.16]	54	5.665 [143.89]	6.065 [154.05]	6.355 [161.42]	110	1-531840-7
56 - 110							
1 - 50	4.900 [124.46]	49	5.165 [131.19]	5.565 [141.35]	5.855 [148.72]	100	1-531840-5
51 - 100							
1 - 45	4.400 [111.76]	44	4.665 [118.49]	5.065 [128.65]	5.355 [136.02]	90	1-531840-3
46 - 90							
1 - 40	3.900 [99.06]	39	4.165 [105.79]	4.565 [115.95]	4.855 [123.32]	80	1-531840-1
41 - 80							
1 - 35	3.400 [86.36]	34	3.665 [93.09]	4.065 [103.25]	4.355 [110.62]	70	531840-9
36 - 70							
1 - 30	2.900 [73.66]	29	3.165 [80.39]	3.565 [90.55]	3.855 [97.92]	60	531840-7
31 - 60							
1 - 25	2.400 [60.96]	24	2.665 [67.69]	3.065 [77.85]	3.355 [85.22]	50	531840-5
26 - 50							
1 - 20	1.900 [48.26]	19	2.165 [54.99]	2.565 [65.15]	2.855 [72.52]	40	531840-3
21 - 40							
1 - 15	1.400 [35.56]	14	1.665 [42.29]	2.065 [52.45]	2.355 [59.82]	30	531840-1
16 - 30							
CAVITY IDENTIFICATION	E	D	C	B	A	NO OF POSN	PART NUMBER

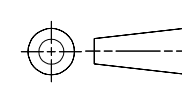
<small>THIS DRAWING IS A CONTROLLED DOCUMENT FOR AMP INCORPORATED. IT IS SUBJECT TO CHANGE AND THE CONTROLLING ENGINEERING ORGANIZATION SHOULD BE CONTACTED FOR THE LATEST REVISION.</small>		DWN T. ALEXANDER 10-20-94 CHK G. SCHAEFFER 1-23-95 APVD G. SCHAEFFER 1-23-95	AMP AMP Incorporated Harrisburg, PA 17105-3608
DIMENSIONS: mm 	TOLERANCES UNLESS OTHERWISE SPECIFIED: 0 PLC ±- 1 PLC ±- 2 PLC ±- 3 PLC ±.010 [0.25] 4 PLC ±- ANGLES ±0° 30' FINISH -	NAME RECEPTACLE HOUSING, BOX CONNECTOR, .100 FOR TANDEM SPRING	SIZE A2 CAGE CODE 00779 DRAWING NO C-531840
MATERIAL -		APPLICATION SPEC - WEIGHT - CUSTOMER DRAWING	SCALE - SHEET 2 OF 2 REV C

531840