



800-824 MHz Cavity Bandpass Filter

Part Number: AB815B899



ANATECH ELECTRONICS INC
RF & Microwave Filters & Products

Electrical specifications

- Passband Range:** 800-824 MHz
- Passband Insertion Loss:** <1.1 dB
- Passband Ripple:** <0.6 dB P-T-P
- Rejection 1:** @DC-800 MHz 50 dB min, 60 dB typ
- Rejection 2:** @passband +/- 4 MHz 30 dB min 35 dB typ
- Rejection 3:** @840-2400 MHz 50 dB min 55 dB typ
- Passband Return Loss:** -18 dB max, <1.28:1
- Input/Output Impedance:** 50 Ohm
- RF Power Capability CW:** 30 Watts

Mechanical

- Mounting Method:** Threaded Mounting Holes
- Connector Type:** SMA Female
- Dimensions:** 4.60" X 2.24" X 2.32" in

Environmental

- Operating Temperature:** -45 to +85° C
- Storage Temperature:** -55 to +95° C
- Shock:** 20 G. 11ms
- Vibration:** 20 G. 5 to 200 MHz

Outline Drawing:

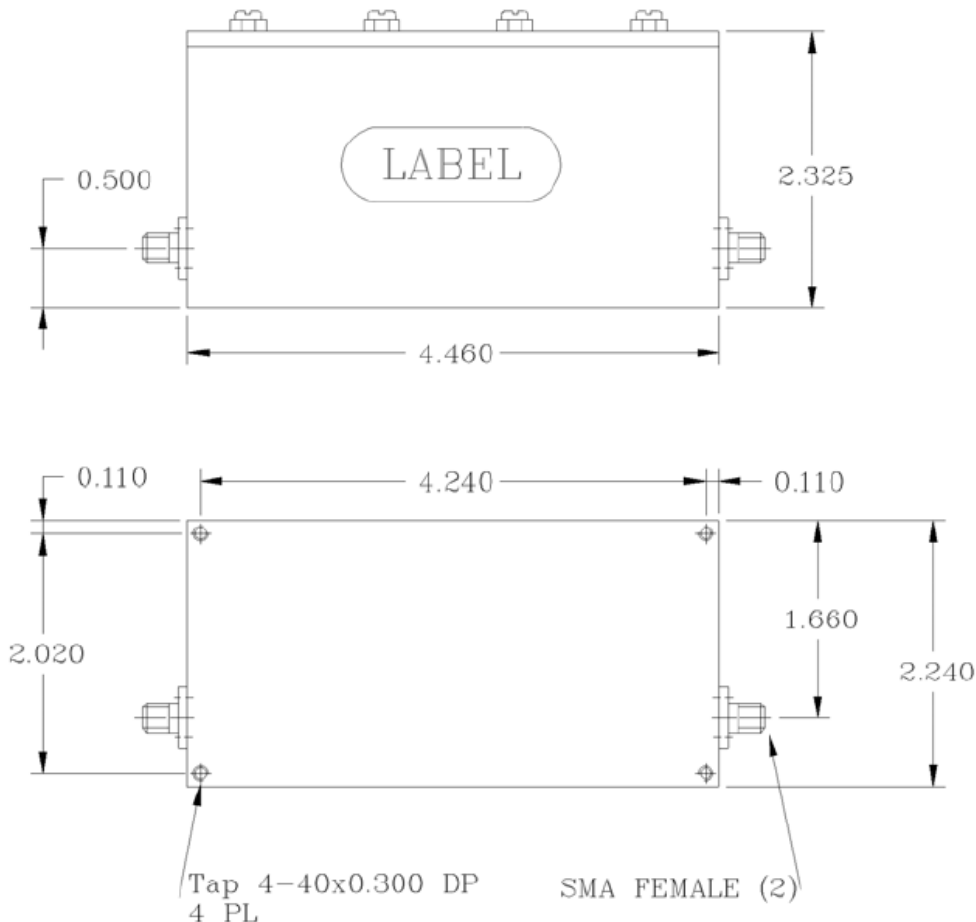



800-824 MHz Cavity Bandpass Filter

Part Number: AB815B899

ANATECH ELECTRONICS INC
RF & Microwave Filters & Products



Plot:

