

© COPYRIGHT 1976 BY AMP INCORPORATED, HARRISBURG, PA.
 ALL INTERNATIONAL RIGHTS RESERVED. AMP INCORPORATED PRODUCTS
 COVERED BY U. S. AND FOREIGN PATENTS AND/OR PATENTS PENDING.

REVISIONS						
P	F	ZONE	LTR	DESCRIPTION	DATE	APPROVED
			A	REVISED DIM.	DS	1-27-76
			B	WAS SK-54106-2	DS	4-7-76
			C	ADDED STRENGTHENING RIBS	DS	10-11-76
			D	ADDED NOTE 1	DS	4-29-77
✓	✓		E	REV PER DF-0693	TS	8-11-88
✓	✓		F	REV PER 0600-2174-94	TT	3-22-95
			G	REV PER OH14-0192-05		1-06

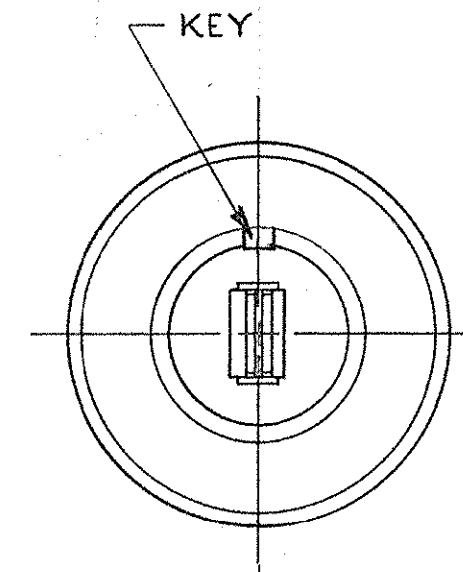
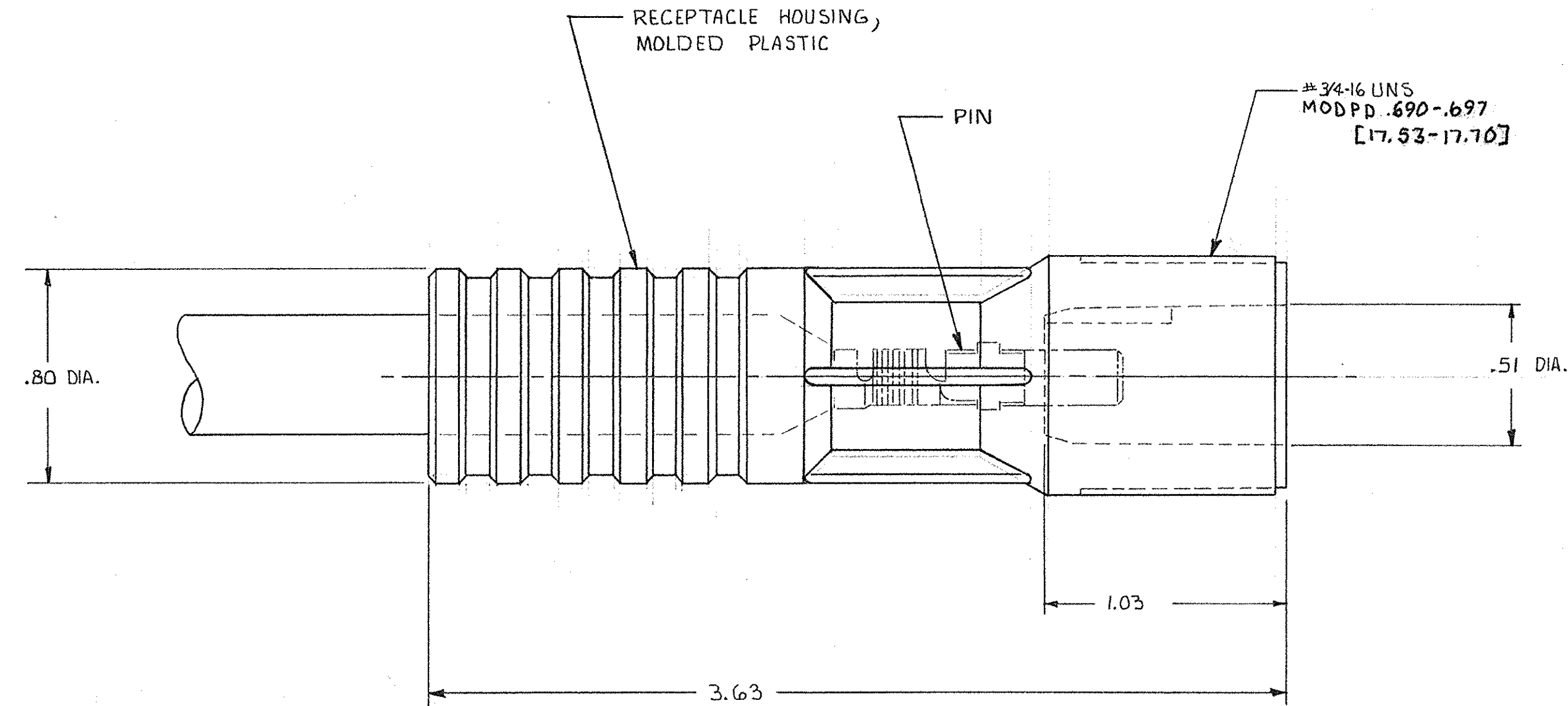

UNPUBLISHED COPY NOT TO BE
 REPRODUCED NOR PUBLISHED
 WITHOUT WRITER PERMISSION
 OF AMP INCORPORATED.

PART NO.	WIRE SIZE RANGE (AWG)	PIN NO.	DIE INSERT NOS. HAND TOOL 69710-1 OR PNEUMATIC TOOL 69365
863104-1	8-10	66259-1	90140-1
863104-2	12-14	66261-1	90145-1
863104-3	16	66261-1	90145-2
5-863104-1	8-10	66259-5	90140-1

OBSOLETE

NOTE:
 1. EXTRACTION TOOL # 863558-1.

				UNLESS OTHERWISE SPECIFIED DIMENSIONS ARE IN INCHES. TOLERANCES: .00 ± .02 .000 ± .005 ANGLES ±		CONTRACT NO DR DICK STONE 1-13-76 CHK		AMP INCORPORATED Elizabethtown, Pa.			
				MATERIAL MOLDED PLASTIC		APPD <i>J. Ashman</i> 1-15-76 APPD		NAME LGH CSL RECEPTACLE ASSEMBLY LGH			
				FINISH BLACK		DSGN APPD		SIZE CODE IDENT NO DRAWING NO C 00779 863104			
NEXT ASSY		FINAL ASSY		NEXT ASSY		USED ON		SCALE ~			
QTY REQD		APPLICATION								SHEET 1 of 1	