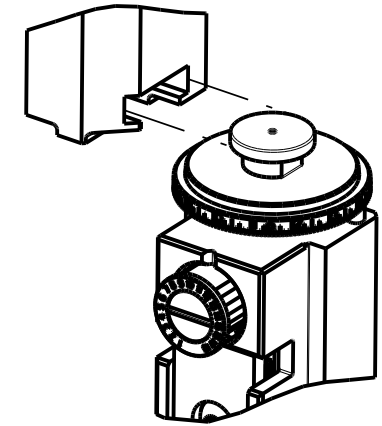
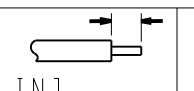

ATLANTIC VERSION TERMINATOR INTERFACE ADAPTER	PART NUMBER	REVISION	DESCRIPTION	FEED TYPE	APPLICATOR STYLE CONVERSION CHART						
					CONVERT TO	PART NUMBERS REQUIRED					
	2150396-2	A	FINE CRIMP HEIGHT ADJUST	PNEUMATIC	-	-	-	-	-	-	
	2150396-5	A	FINE CRIMP HEIGHT ADJUST	SERVO LATCH PLATE ⁴	SERVO LATCH PLATE	2119951-1	1901697-1	8-2150396-5	-	-	2168400-7 (QUANTITY 2)
					SMART APPLICATOR	2161326-1	-	8-2150396-4	-	-	-
	2150396-6	A	NON-CRIMP HEIGHT ADJUST	SERVO LATCH PLATE ⁴	PNEUMATIC FEED	2119950-1	2119792-2	-	2119641-1	-	2063440-2
					-	-	-	-	-	-	-
	2150396-7	A	FINE CRIMP HEIGHT ADJUST	NONE	-	-	-	-	-	-	-
	7-2150396-7	A	CRIMP TOOLING KIT	-	-	-	-	-	-	-	-

APPLICATOR DATA		
CRIMP	SIZE	TYPE
WIRE	2.79 mm [.110]	F
INSUL	4.06 mm [.160]	F
APPL INSTRUCTIONS 408-10390		

TERMINAL DATA: KET TERMINAL		TE CRIMP SPECIFICATION	
TERMINAL NAME: 312 CONNECTOR			
WIRE STRIP LENGTH		INSULATION DIAMETER RANGE	
5.24-5.25 mm [.206-.207 IN]		Ø1.80-2.18 mm [.071-.086 IN]	
TERMINAL APPLICATION SPECIFICATION	NONE		
TERMINALS APPLIED			
TE TERMINAL	KET TERMINAL	TE TERMINAL	KET TERMINAL
1949545-1	ST730371-1	1949545-2	ST730371-3

WIRE SIZE	CRIMP HEIGHT mm [INCH]	CRIMP HEIGHT REFERENCE SETTING
2.00mm2	1.93+/-0.05 [.076+/-0.002]	3.6
1.50mm2	1.78+/-0.05 [.070+/-0.002]	5.0
1.00mm2	1.63+/-0.05 [.064+/-0.002]	6.6
0.75mm2	1.56+/-0.05 [.061+/-0.002]	7.5
0.50mm2	1.48+/-0.05 [.058+/-0.002]	8.2

- ¹ RECOMMENDED SPARE PARTS
- ² GREASE BEARING SURFACES LIGHTLY
- 3. LUBRICATE DAILY PER THE APPLICATOR INSTRUCTION SHEET SUPPLIED WITH THE APPLICATOR.
- ⁴ APPLICATOR SPECIFIC DATA TO BE ENTERED INTO BLANK MEMORY CHIP AT ASSEMBLY. SEE BELOW FOR PART NUMBER:
 PNEUMATIC FEED WITH "SMART APPLICATOR" CONVERSION: 8-2150396-4
 SERVO FEED WITH "FINE CRIMP HEIGHT ADJUST": 8-2150396-5
 SERVO FEED WITH "NON-CRIMP HEIGHT ADJUST": 8-2150396-6
- 5. ADJUSTMENT OF THE STRIPPER MAY BE REQUIRED WHEN MOVING THE APPLICATOR BETWEEN BENCH AND LEADMAKER APPLICATIONS.
- ⁶ APPLY PART NUMBER 1-23419-5 LOCTITE TO THREADS OF ITEMS 50, 62 & 242. FOR -6 ONLY APPLY PART NUMBER 1-23419-5 LOCTITE TO THREADS OF ITEMS 37, 50 & 242.
- ⁷ GREASE THREADS, GROOVE AND O-RING ON ITEMS 35 & 252.
- ⁸ MAGNET, ITEM 166 MUST BE ORIENTED CORRECTLY IN ORDER TO PROPERLY ACTUATE THE COUNTER.
- ⁹ CRIMP HEIGHT REFERENCE SETTING WAS THE SETTING USED WHEN THE APPLICATOR WAS QUALIFIED AT THE FACTORY. ADJUSTMENT MAY BE NECESSARY WHEN RUNNING APPLICATOR IN THE FIELD.
- ¹⁰ TERMINAL PITCH NOT COMPATIBLE WITH MECHANICAL FEED.
- ¹¹ THE RECOMMENDED SET-UP FOR END FEED APPLICATORS IS POST-FEED WITH ITEM 2119653-1. THE APPLICATOR CAN BE CONFIGURED FOR PRE-FEED WITH ITEM 2119652-1 BUT MAY ENCOUNTER PROBLEMS WITH SOME APPLICATIONS. FEED ISSUES OR TERMINAL JAMMING MAY OCCUR IN THE PRE-FEED CONFIGURATION.
- ¹² WHEN ASSEMBLING -6 NON-CRIMP HEIGHT ADJUST APPLICATOR USE SHIM PACK 2119957-2 TO ALIGN APPLICATOR'S MAXIMUM WIRE CRIMP HEIGHT AT NORMAL TERMINATOR SHUT HEIGHT

***WARNING**
 ON INSTALLATION, SET WIRE DISC, ITEM 40 TO LARGEST WIRE SIZE SETTING. USE OF SETTINGS BELOW MINIMUM REQUIRED CRIMP HEIGHT SETTING WILL CAUSE DAMAGE TO CRIMP TOOLING.

-	-	1	-	-	2119957-2	APPLICATOR SHIM PACK	260
-	1	-	1	1	8-21084-0	O-RING, .676 ID, .070 DIA. MAT.	252
-	-	-	-	1	2119640-1	PUSH ROD, AIR FEED	250
-77	-7	-6	-5	-2	PART NO	DESCRIPTION	ITEM NO

ATLANTIC VERSION
 Shown on sheets 1 of 4 & 2 of 4
 (Pacific version shown on sheets 3 of 4 & 4 of 4)

SET UP GAUGE	LOC	DIST	REVISIONS			
2119599-2	A	66	REV	DATE	OWN	APVD
	A		RELEASED	20DEC2013	LG	TE
	A1		ECR-14-001140	26JAN2014	YY	UG

-	-	-	-	1	2079988-1	BUSHING, LCH5-12, MISUMI	249	
-	-	-	-	1	2119641-1	FEED CAM, AIR FEED	248	
-	1	-	-	1	2119798-1	DETENT PIN	247	
-	1	-	-	1	1-22279-3	SPRING, COMPRESSION	246	
-	-	1	-	-	2119759-1	RAM, AMP STYLE, END FEED, NON-ADJUST	245	
-	1	1	-	1	2119082-9	CAM, SNAIL, INSULATION ADJUSTMENT	244	
-	1	1	1	1	2079764-1	WASHER, WAVE SPRING, CREST-TO-CREST	243	
-	1	1	1	1	2119083-1	RETAINER, INSULATION DIAL	242	
-	-	2	2	-	2168400-7	SHCS, LOW HEAD, RoHS, M5 X 10	240	
-	-	-	-	1	2063440-2	AIR FEED MODULE	238	
-	-	1	1	-	2119740-2	TAG, IDENTIFICATION	213	
-	-	REFREF	-	-	1901697-1	FEED FINGER ASSEMBLY, EF	183	
-	1	1	1	1	6-993111-6	PIN, SLOTTED SPRING 3.0 X 14.0	177	
-	1	1	1	1	8-22280-7	SPRING, COMPRESSION	176	
-	1	1	1	1	1752353-2	GUIDE PIN, HOLDDOWN	175	
-	1	1	1	1	1901680-2	GUIDE PIN, HOLDDOWN	174	
-	-	-	-	2	21045-3	RING, RETAIN, EXTERN, 3/16 CRESCENT	172	
-	1	1	1	1	994969-1	MAGNET, RARE EARTH HIGH ENERGY	166	
-	REFREF	REFREF	REFREF	-	994970-2	COUNTER, MAGNETIC	164	
-	-	-	-	1	240638-1	SPRING, FEED FINGER	163	
-	-	-	-	1	3-23627-7	PIN, RETAIN, GRVD, 3/16 X .854	137	
-	REFREF	-	-	-	-	SEE NOTE 4	MEMORY CHIP, PROGRAMMED	135
-	1	1	1	-	1633743-1	SERVO FEED LATCH ASM	133	
-	1	1	1	1	455888-5	SPACER, CRIMPER	82	
-	1	1	1	1	2119956-2	DOCUMENTATION PACKAGE	71	
-	2	2	2	2	2-18032-2	SCR, SET, FLT POINT M3 X 10.0	70	
-	1	-	-	1	2119740-1	TAG, IDENTIFICATION	67	
-	2	2	2	2	2168078-1	SCREW, DRIVE, RH, RoHS, 2 x .188	66	
-	1	1	1	1	1901681-1	HOLDDOWN, TERMINAL	65	
-	2	2	2	2	2168400-5	SHCS, LOW HEAD, RoHS, M4 X 20	64	
-	1	-	-	1	2119793-1	LIMITER, ADJUSTMENT BOLT	63	
-	3	-	-	3	992763-5	SCR, SET, SOC, CONE POINT, M3 x 4.0	62	
-	1	1	1	1	2079383-4	SCR, BHSC, RoHS (M4 X 8)	60	
-	3	3	3	3	2168400-4	SHCS, LOW HEAD, RoHS, M4 X 8	57	
-	2	2	2	2	2168083-8	SCR, SKT HD CAP, RoHS, M4 X 16	56	
-	2	2	2	2	5018030-2	NUT, HEX, REG, RoHS, M4	55	
-	2	2	2	2	5018030-1	NUT, HEX, REG, RoHS, M3	54	
-	2	2	2	2	986965-8	NUT, LOCK, HEX, TORQUE (M4)	53	
-	1	1	1	1	1-5018030-0	NUT, HEX, REG, RoHS, M3.5	52	
-	-	-	-	1	2119792-2	PAWL, EF, AIR	51	
-	1	1	1	1	1-1752354-1	STANDOFF, HOLD-DOWN	50	
-	-	-	-	1	18023-9	SCR, SKT HD CAP M4 X 6.0	49	
-	1	1	1	1	2119655-5	APPLICATOR BASIC ASSEMBLY, EF	46	
-	1	-	-	1	2119369-1	RAM, AMP STYLE, END FEED	44	
-	1	1	1	1	2079383-7	SCR, BHSC, RoHS (M8 X 25)	41	
-	1	-	-	1	2119645-1	DISC, NUMBERED FA WIRE ADJUSTMENT	40	
-	1	-	-	1	2119957-1	APPLICATOR SHIM PACK	39	
-	1	1	1	1	1-2119644-2	RAM WASHER, PRECISION	38	
-	1	1	1	1	2119085-1	FA HEAD, ATLANTIC STYLE	37	
-	1	-	-	1	2119092-1	BOLT, ADJUSTMENT	35	
-	7	7	7	7	1-18028-2	WASHER, FLAT, REG M4	33	
-	2	2	2	2	2168083-9	SCR, SKT HD CAP, RoHS, M4 X 20	31	
-	2	2	2	2	1-2168083-0	SCR, SKT HD CAP, RoHS, M4 X 10	29	
-	1	1	1	1	240639-1	STRIPPER (MACHINING)	27	
-	2	2	2	2	1320906-1	STUD, THREADED	25	
-	1	1	1	1	1752371-5	PLATE, STRIP GUIDE	24	
-	1	1	1	1	240825-1	PLATE, STRIP HOLD DOWN	23	
-	2	2	2	2	2-22281-3	SPRING, COMPRESSION	22	
-	1	1	1	1	1752373-4	DRAG	20	
-	2	2	2	2	1901259-6	GUIDE, LOWER STRIP	18	
-	4	4	4	4	1-2079383-1	SCR, BHSC, RoHS (M6 X 12)	17	
-	1	1	1	1	1752360-1	SPACER, HOLD-DOWN	13	
-	1	1	1	1	240644-1	PLATE, REAR SHEAR	11	
-	-	-	-	-	-	-	10	
-	1	1	1	1	690482-3	PLATE, FRONT SHEAR	9	
-	1	1	1	1	3-1803000-9	ANVIL, COMBINATION, END FEED	8	
-	1	1	1	1	1-2217206-3	BLADE, SLUG	7	
-	-	-	-	-	-	-	6	
-	1	1	1	1	5-240641-3	SPACER	5	
-	1	1	1	1	238009-1	BLOCK, FL CRIMPER SPACER	4	
-	1	1	1	1	3-2119582-4	CRIMPER, INSULATION F PREMIUM	3	
-	1	1	1	1	1-455888-4	SPACER, CRIMPER	2	
-	1	1	1	1	3-456408-1	CRIMPER, WIRE PREMIUM	1	
-77	-7	-6	-5	-2	PART NO	DESCRIPTION	ITEM NO	

DIMENSIONS:		TOLERANCES UNLESS OTHERWISE SPECIFIED:		DWG		REV	
mm	0 PLC ±.5	1 PLC ±.5	2 PLC ±.5	3 PLC ±.5	4 PLC ±.5	5 PLC ±.5	6 PLC ±.5
	ANGLES ±.0001						
	FINISH						
MATERIAL		WEIGHT		SCALE	1:1	SHEET	1 OF 4
		Customer Accessible Production Drawing					

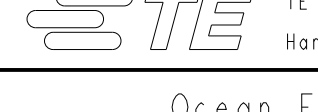

TE Connectivity
Harrisburg, PA 17105-3608

Product Name: Ocean End Feed Applicator

Part Number: 2150396

REVISONS		DATE	DMN	APVD
LOC	DIST			
A	66			
DESCRIPTION				
SEE SHEET 1				

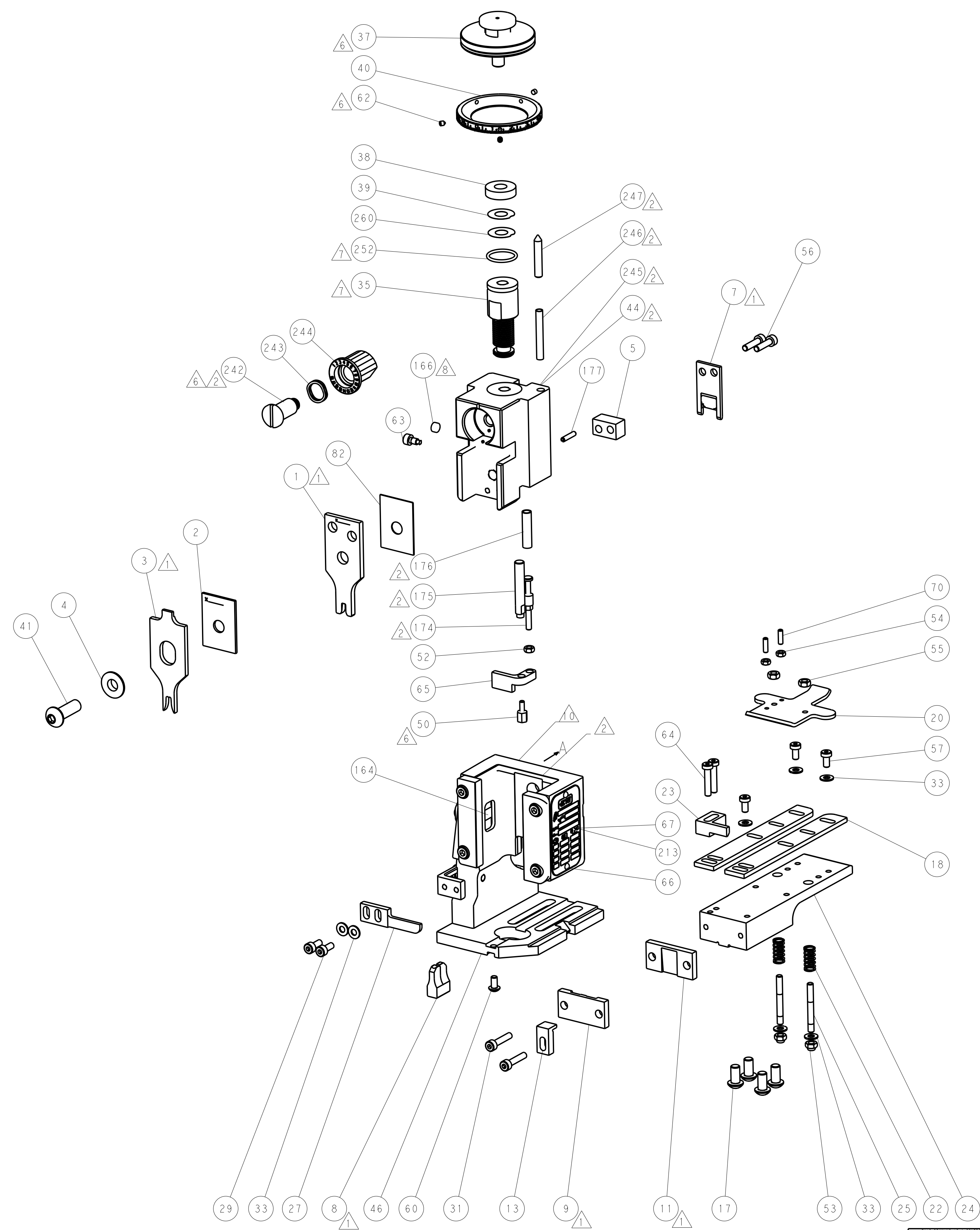
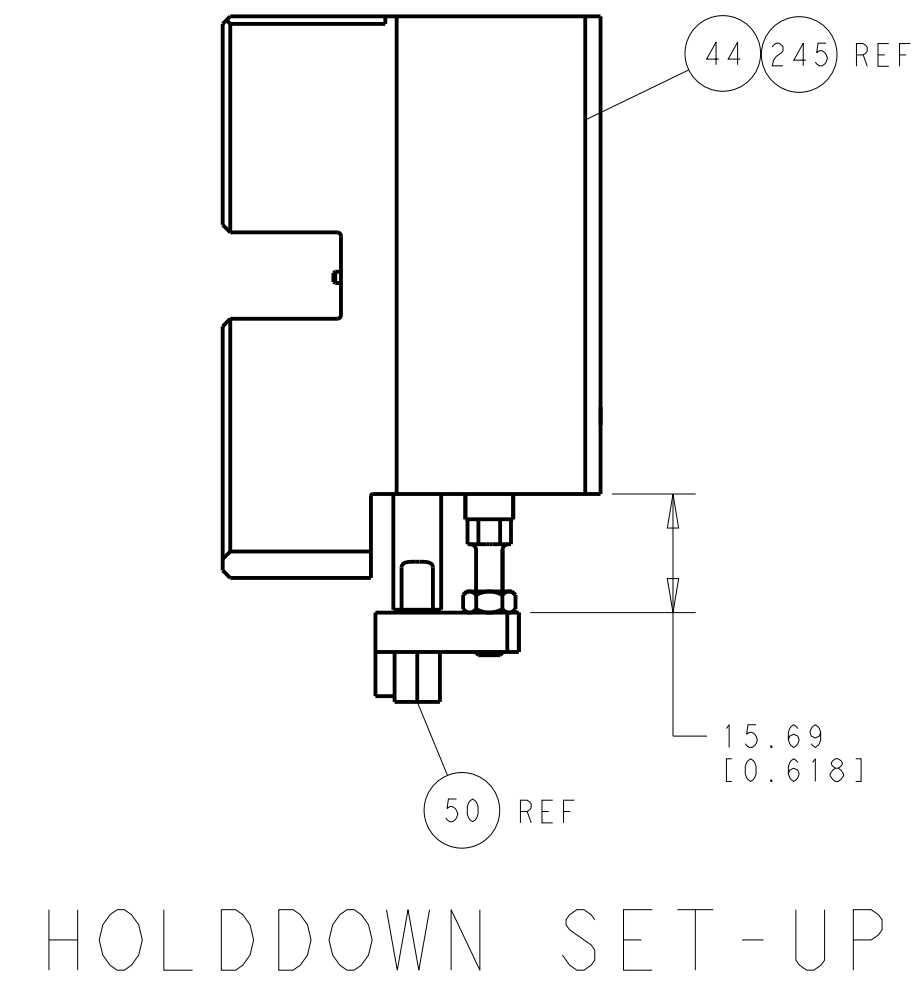

FEED TYPE
 PNEUMATIC

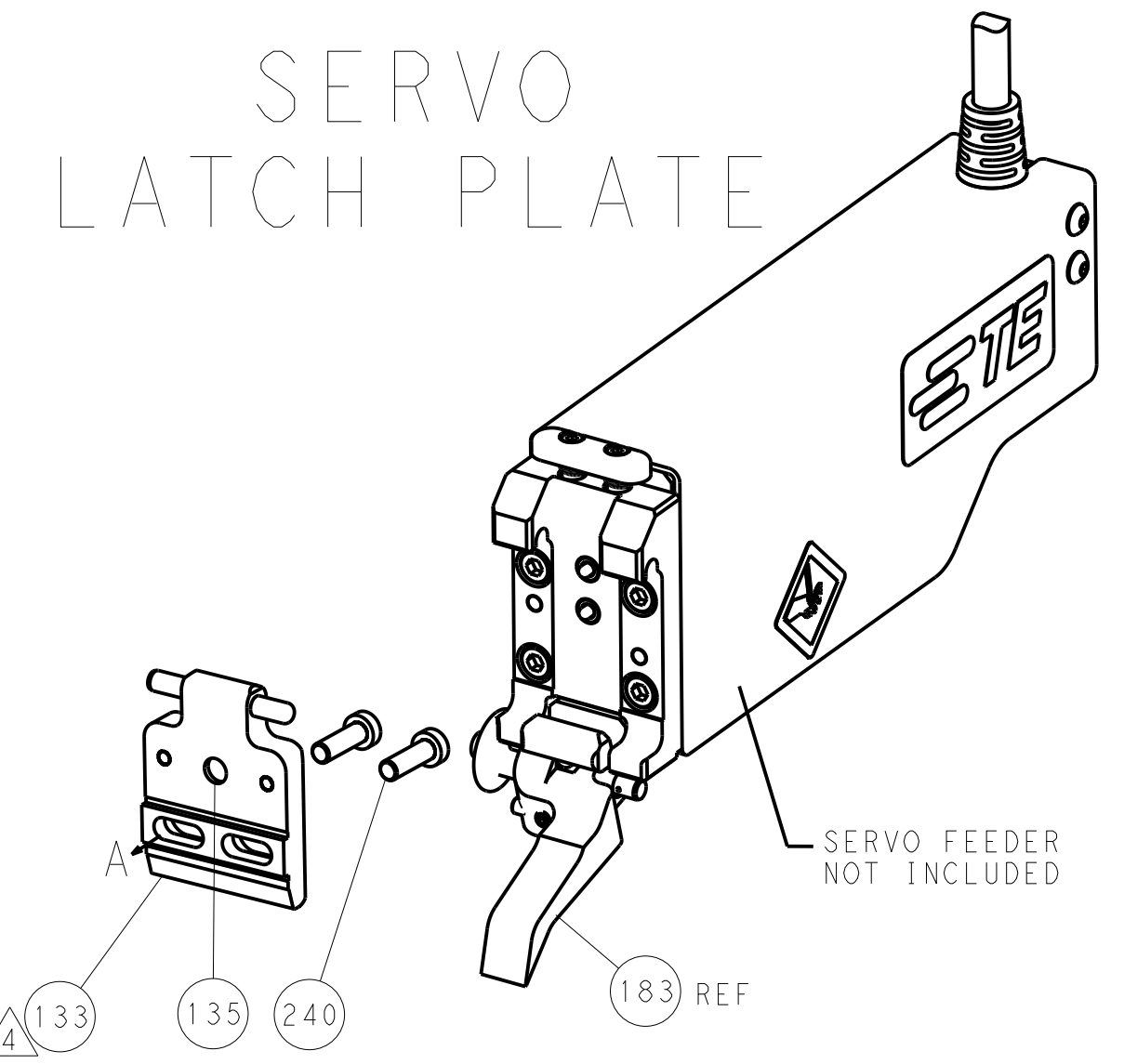
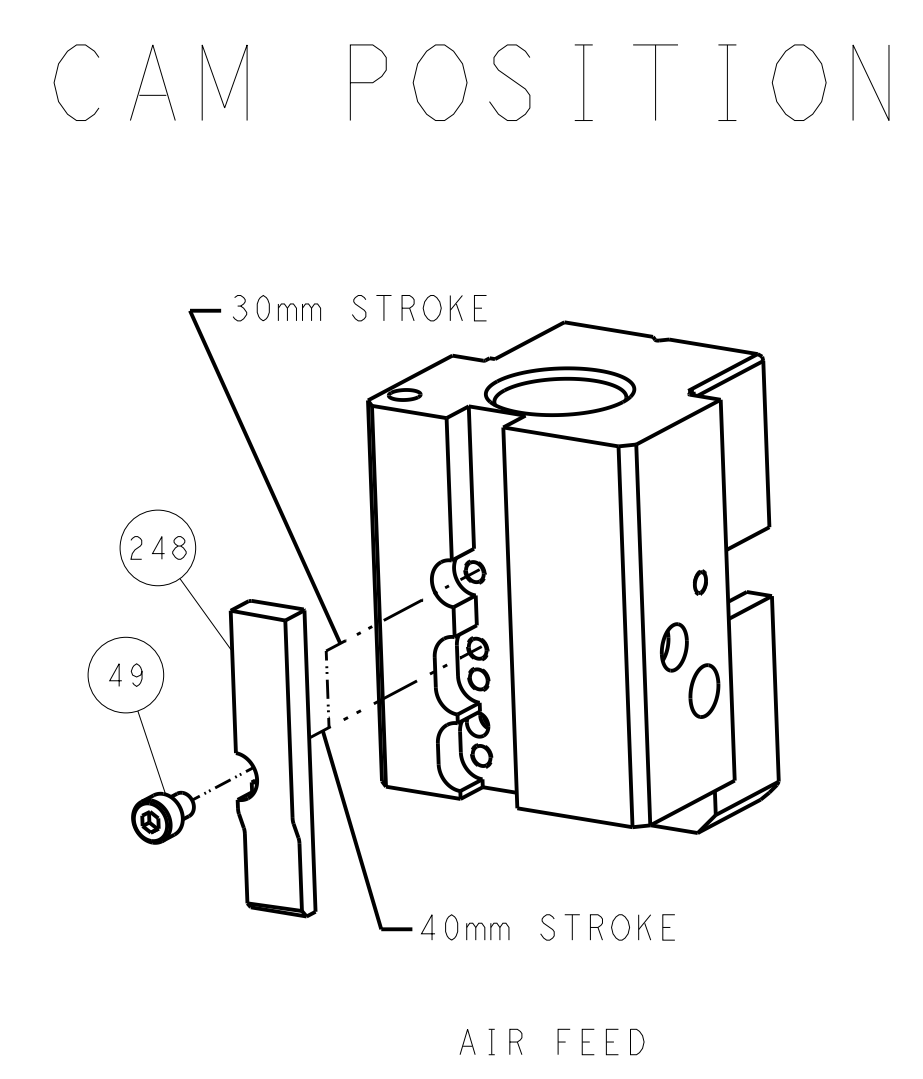
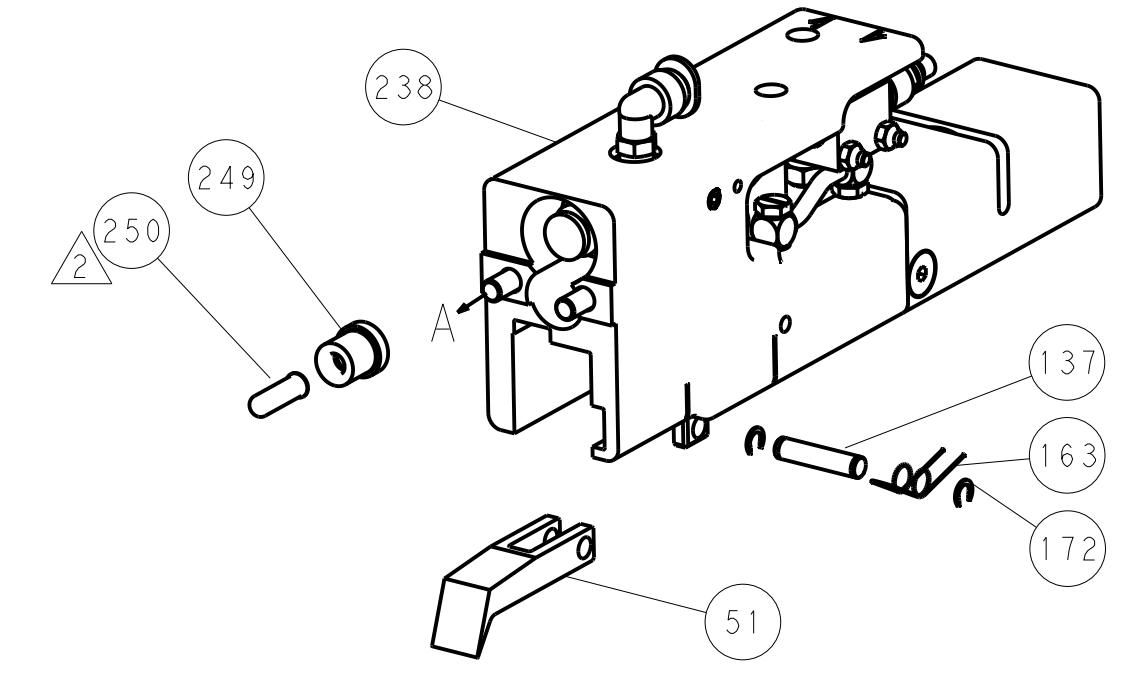

ATLANTIC VERSION
 Shown on sheets 1 of 4 & 2 of 4
 (Pacific version shown on sheets 3 of 4 & 4 of 4)

DIMENSIONS:		TOLERANCES UNLESS OTHERWISE SPECIFIED:		DWG: Y. YIN 05NOV2013		TE Connectivity	
mm	0 PLC ±0.5	1 PLC ±0.5	2 PLC ±0.13	3 PLC ±0.013	4 PLC ±0.001	APVD: G. BAILEY 05NOV2013	Harrisburg, PA 17105-3608
MATERIAL:		FINISH:		PRODUCT SPEC:		NAME: Ocean End Feed Applicator	
				APPLICATION SPEC:		SIZE: CAGE CODE: DRAWING NO: A1 00779 ©=2150396	
				WEIGHT:		RESTRICTED TO:	
				CUSTOMER ACCESSIBLE PRODUCTION DRAWING		SCALE: 1:1 SHEET 2 OF 4 REV A1	

PACIFIC VERSION TERMINATOR INTERFACE ADAPTER	PART NUMBER	REVISION	DESCRIPTION	FEED TYPE	APPLICATOR STYLE CONVERSION CHART						
					CONVERT TO	PART NUMBERS REQUIRED					
	2-2150396-2	A	FINE CRIMP HEIGHT ADJUST	PNEUMATIC	-	-	-	-	-	-	-
					SERVO LATCH PLATE	2119951-1	1901697-1	8-2150396-5	-	-	2168400-7 (QUANTITY 2)
	2-2150396-5	A	FINE CRIMP HEIGHT ADJUST	SERVO LATCH PLATE ⁴	-	-	-	-	-	-	-
					PNEUMATIC FEED	2119950-1	2119792-2	-	2119641-2	-	2063440-2
2-2150396-7	A	FINE CRIMP HEIGHT ADJUST	NONE	-	-	-	-	-	-	-	
7-2150396-7	A	CRIMP TOOLING KIT	-	-	-	-	-	-	-	-	

APPLICATOR DATA		
CRIMP	SIZE	TYPE
WIRE	2.79 mm [1.10]	F
INSUL	4.06 mm [1.60]	F
APPL INSTRUCTIONS 408-10390		

TERMINAL DATA: KET TERMINAL		TE CRIMP SPECIFICATION	
TERMINAL NAME: 312 CONNECTOR			
WIRE STRIP LENGTH		INSULATION DIAMETER RANGE	
5.24-5.25 mm [1.206-1.207 IN]		1.80-2.18 mm [1.071-.086 IN]	
TERMINAL APPLICATION SPECIFICATION	NONE	-	-
TERMINALS APPLIED			
TE TERMINAL	KET TERMINAL	TE TERMINAL	KET TERMINAL
1949545-1	ST730371-1	1949545-2	ST730371-3

WIRE SIZE	CRIMP HEIGHT mm [INCH]	CRIMP HEIGHT REFERENCE SETTING ⁹
2.00mm2	1.93 +/- 0.05 [1.076 +/- .002]	3.6
1.50mm2	1.78 +/- 0.05 [1.070 +/- .002]	5.0
1.00mm2	1.63 +/- 0.05 [1.064 +/- .002]	6.6
0.75mm2	1.56 +/- 0.05 [1.061 +/- .002]	7.5
0.50mm2	1.48 +/- 0.05 [1.058 +/- .002]	8.2

- RECOMMENDED SPARE PARTS
- GREASE BEARING SURFACES LIGHTLY
- 3. LUBRICATE DAILY PER THE APPLICATOR INSTRUCTION SHEET SUPPLIED WITH THE APPLICATOR.
- APPLICATOR SPECIFIC DATA TO BE ENTERED INTO BLANK MEMORY CHIP AT ASSEMBLY. SEE BELOW FOR PART NUMBER:
 PNEUMATIC FEED WITH "SMART APPLICATOR" CONVERSION: 8-2150396-4
 SERVO FEED WITH "FINE CRIMP HEIGHT ADJUST": 8-2150396-5
- 5. ADJUSTMENT OF THE STRIPPER MAY BE REQUIRED WHEN MOVING THE APPLICATOR BETWEEN BENCH AND LEADMAKER APPLICATIONS.
- APPLY PART NUMBER 1-23419-5 LOCTITE TO THREADS OF ITEMS 50, 62 & 242.
- GREASE THREADS, GROOVE AND O-RING ON ITEMS 139 & 153.
- MAGNET, ITEM 166 MUST BE ORIENTED CORRECTLY IN ORDER TO PROPERLY ACTUATE THE COUNTER.
- CRIMP HEIGHT REFERENCE SETTING WAS THE SETTING USED WHEN THE APPLICATOR WAS QUALIFIED AT THE FACTORY. ADJUSTMENT MAY BE NECESSARY WHEN RUNNING APPLICATOR IN THE FIELD.
- TERMINAL PITCH NOT COMPATIBLE WITH MECHANICAL FEED.
- THE RECOMMENDED SET-UP FOR END FEED APPLICATORS IS POST-FEED WITH ITEM 2119653-1. THE APPLICATOR CAN BE CONFIGURED FOR PRE-FEED WITH ITEM 2119652-1 BUT MAY ENCOUNTER PROBLEMS WITH SOME APPLICATIONS. FEED ISSUES OR TERMINAL JAMMING MAY OCCUR IN THE PRE-FEED CONFIGURATION.

***WARNING**
 ON INSTALLATION, SET WIRE DISC, ITEM 40 TO LARGEST WIRE SIZE SETTING. USE OF SETTINGS BELOW MINIMUM REQUIRED CRIMP HEIGHT SETTING WILL CAUSE DAMAGE TO CRIMP TOOLING.

-	1	1	1	2119782-1	FINE ADJUST HEAD ASM, PACIFIC STYLE	251
-77-27-25-22				PART NO	DESCRIPTION	ITEM NO

PACIFIC VERSION
 Shown on sheets 3 of 4 & 4 of 4
 (Atlantic version shown on sheets 1 of 4 & 2 of 4)

SET UP GAUGE	LOC	DIST	REVISIONS			
2119599-2	A	66	REV	DATE	BY	APPD
			-	SEE SHEET 1	-	-

-	-	-	1	2119640-1	PUSH ROD, AIR FEED	250
-	-	-	1	2079988-1	BUSHING, LCH5-12, MISUMI	249
-	1	1	1	1-22279-3	SPRING, COMPRESSION	246
-	1	1	1	2119082-9	CAM, SNAIL, INSULATION ADJUSTMENT	244
-	1	1	1	2079764-1	WASHER, WAVE SPRING, CREST-TO-CREST	243
-	1	1	1	2119083-1	RETAINER, INSULATION DIAL	242
-	-	2	-	2168400-7	SHCS, LOW HEAD, RoHS, M5 X 10	240
-	-	-	1	2063440-2	AIR FEED MODULE	238
-	-	1	-	2119740-2	TAG, IDENTIFICATION	213
-	4	4	4	2079383-9	SCR, BHSC, RoHS (M6 X 20)	186
-	-	REF	-	1901697-1	FEED FINGER ASSEMBLY, EF	183
-	1	1	1	6-993111-6	PIN, SLOTTED SPRING 3.0 X 14.0	177
-	1	1	1	8-22280-7	SPRING, COMPRESSION	176
-	1	1	1	1752353-2	GUIDE PIN, HOLDDOWN	175
-	1	1	1	1901680-2	GUIDE PIN, HOLDDOWN	174
-	-	-	2	21045-3	RING, RETAIN, EXTERN, 3/16 CRESCENT	172
-	1	1	1	994969-1	MAGNET, RARE EARTH HIGH ENERGY	166
-	REF	REF	REF	994970-2	COUNTER, MAGNETIC	164
-	-	-	1	240638-1	SPRING, FEED FINGER	163
-	1	1	1	8-21084-1	O-RING, .801 ID, .070 DIA. MAT.	153
-	-	-	1	2119641-2	FEED CAM, AIR FEED	152
-	1	1	1	2119798-2	DETENT PIN	145
-	1	1	1	2079383-8	SCR, BHSC, RoHS (M4 X 16)	144
-	1	1	1	2119655-6	APPLICATOR BASIC ASSEMBLY, EF	141
-	1	1	1	2119651-1	RAM, ASIAN STYLE, END FEED	140
-	1	1	1	2119092-2	BOLT, ADJUSTMENT	139
-	-	-	1	3-23627-7	PIN, RETAIN, GRVD, 3/16 X .854	137
-	-	REF	-	SEE NOTE 4	MEMORY CHIP, PROGRAMMED	135
-	-	1	-	1633743-1	SERVO FEED LATCH ASM	133
-	1	1	1	455888-5	SPACER, CRIMPER	82
-	1	1	1	2119956-2	DOCUMENTATION PACKAGE	71
-	2	2	2	2-18032-2	SCR, SET, FLT POINT M3 X 10.0	70
-	1	-	1	2119740-1	TAG, IDENTIFICATION	67
-	2	2	2	2168078-1	SCREW, DRIVE, RH, RoHS, 2 x .188	66
-	1	1	1	1901681-1	HOLDDOWN, TERMINAL	65
-	2	2	2	2168400-5	SHCS, LOW HEAD, RoHS, M4 X 20	64
-	1	1	1	2119793-1	LIMITER, ADJUSTMENT BOLT	63
-	3	3	3	992763-5	SCR, SET, SOC, CONE POINT, M3 X 4.0	62
-	3	3	3	2168400-4	SHCS, LOW HEAD, RoHS, M4 X 8	57
-	2	2	2	2168083-8	SCR, SKT HD CAP, RoHS, M4 X 16	56
-	2	2	2	5018030-2	NUT, HEX, REG, RoHS, M4	55
-	2	2	2	5018030-1	NUT, HEX, REG, RoHS, M3	54
-	2	2	2	986965-8	NUT, LOCK, HEX, TORQUE (M4)	53
-	1	1	1	1-5018030-0	NUT, HEX, REG, RoHS, M3.5	52
-	-	-	1	2119792-2	PAWL, EF, AIR	51
-	1	1	1	1-1752354-1	STANDOFF, HOLD-DOWN	50
-	-	-	1	18023-9	SCR, SKT HD CAP M4 X 6.0	49
-	1	1	1	2079383-7	SCR, BHSC, RoHS (M8 X 25)	41
-	1	1	1	2119645-1	DISC, NUMBERED FA WIRE ADJUSTMENT	40
-	1	1	1	2119957-1	APPLICATOR SHIM PACK	39
-	1	1	1	1-2119644-2	RAM WASHER, PRECISION	38
-	7	7	7	1-18028-2	WASHER, FLAT, REG M4	33
-	2	2	2	2168083-9	SCR, SKT HD CAP, RoHS, M4 X 20	31
-	2	2	2	1-2168083-0	SCR, SKT HD CAP, RoHS, M4 X 10	29
-	1	1	1	240639-1	STRIPPER (MACHINING)	27
-	2	2	2	1320906-1	STUD, THREADED	25
-	1	1	1	1752371-5	PLATE, STRIP GUIDE	24
-	1	1	1	240825-1	PLATE, STRIP HOLD DOWN	23
-	2	2	2	2-22281-3	SPRING, COMPRESSION	22
-	1	1	1	1752373-4	DRAG	20
-	2	2	2	1901259-6	GUIDE, LOWER STRIP	18
-	1	1	1	1752360-1	SPACER, HOLD-DOWN	13
-	1	1	1	240644-1	PLATE, REAR SHEAR	11
-	-	-	-	-	-	10
-	1	1	1	690482-3	PLATE, FRONT SHEAR	9
1	1	1	1	3-1803000-9	ANVIL, COMBINATION, END FEED	8
-	1	1	1	1-2217206-3	BLADE, SLUG	7
-	-	-	-	-	-	6
-	1	1	1	5-240641-3	SPACER	5
-	1	1	1	238009-1	BLOCK, FL CRIMPER SPACER	4
1	1	1	1	3-2119582-4	CRIMPER, INSULATION F PREMIUM	3
-	1	1	1	1-455888-4	SPACER, CRIMPER	2
1	1	1	1	3-456408-1	CRIMPER, WIRE PREMIUM	1

DIMENSIONS:		TOLERANCES UNLESS OTHERWISE SPECIFIED:		DWG		REV	
mm	0 PLC ±.5	1 PLC ±.5	2 PLC ±.13	3 PLC ±.013	4 PLC ±.0001	5 ANGLE ±.0001	FINISH
MATERIAL		FINISH		DWG NO		REV	
				05NOV2013		05NOV2013	
				Y. YIN		G. BAILEY	
				H. GUO		05NOV2013	
				APVD		NAME	
				PRODUCT SPEC		Ocean End Feed Applicator	
				APPLICATION SPEC		SIZE	
				WEIGHT		CAGE CODE	
				A1		00779	
				Customer Accessible Production Drawing		SCALE	
				1:1		SHEET 3 OF 4	
				REV		A1	

LOC	DIST	REV	DATE	BY	APPV
A	66				

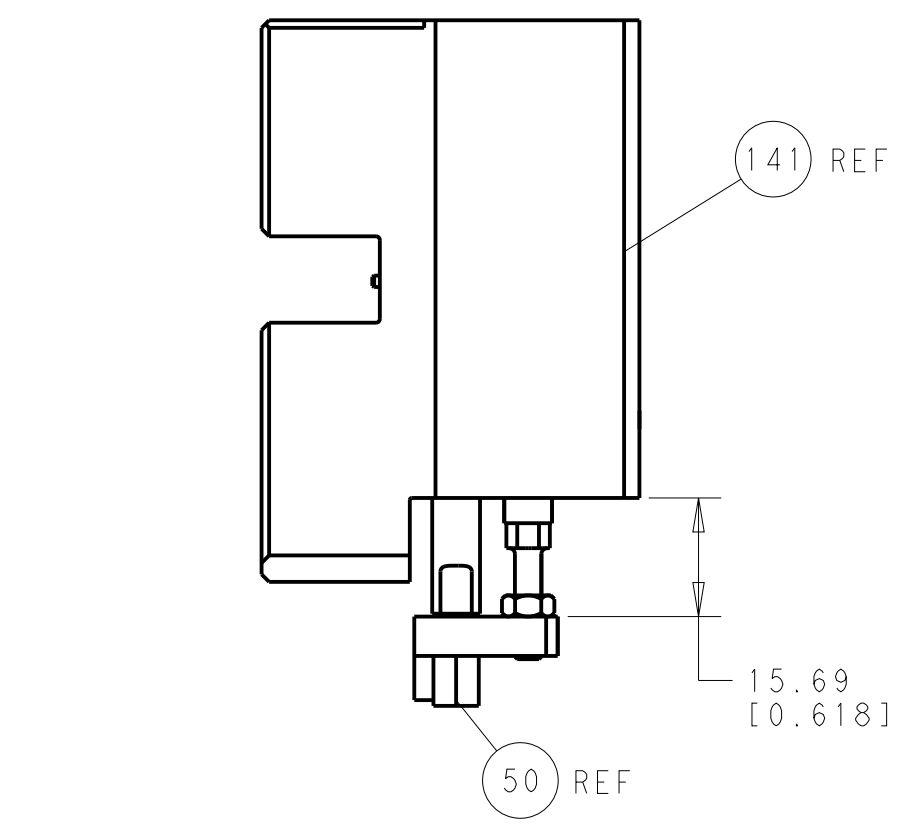

HOLDDOWN SET-UP

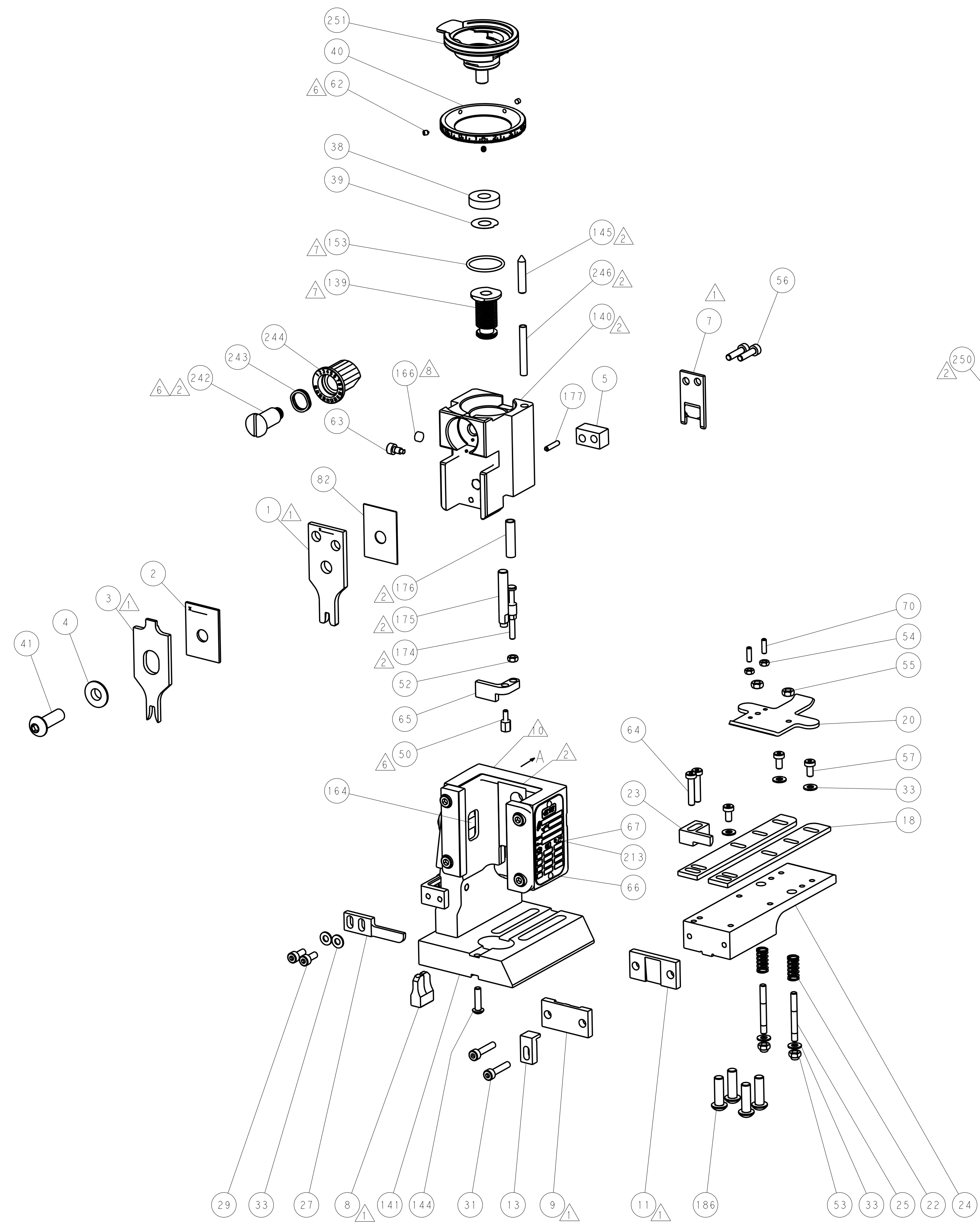

FEED TYPE

PNEUMATIC

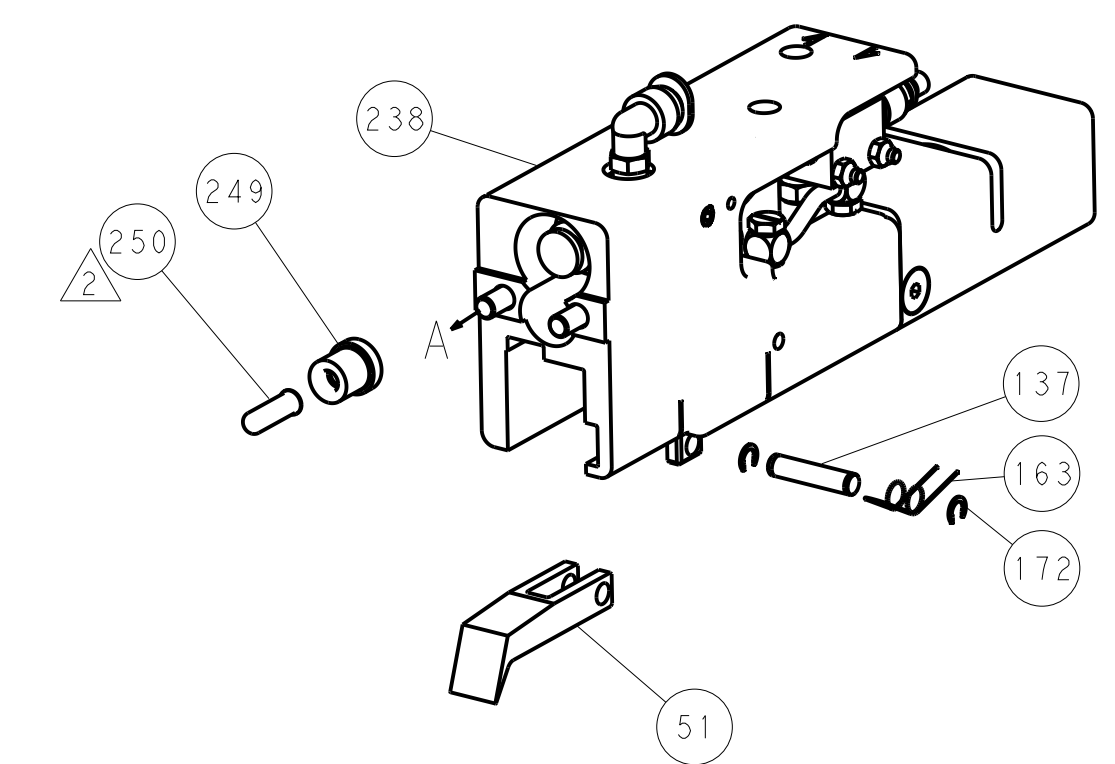

SERVO LATCH PLATE

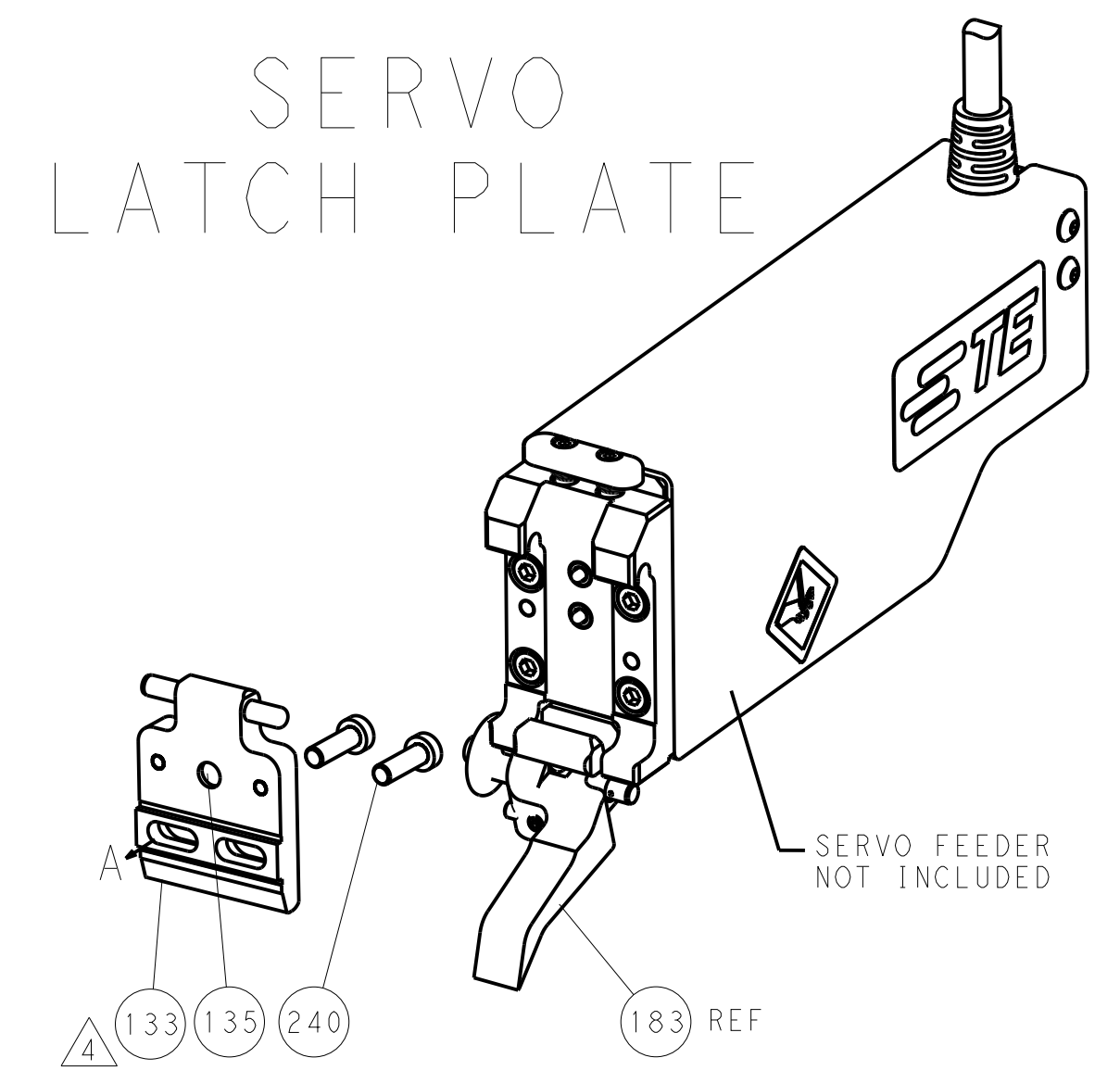

CAM POSITION

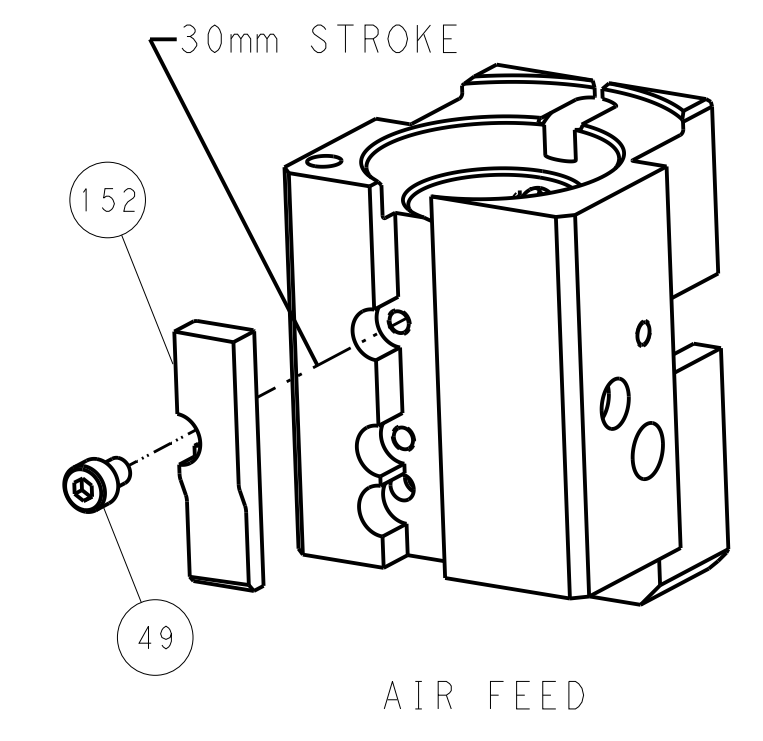

AIR FEED

PACIFIC VERSION
 Shown on sheets 3 of 4 & 4 of 4
 (Atlantic version shown on sheets 1 of 4 & 2 of 4)

DIMENSIONS:		TOLERANCES UNLESS OTHERWISE SPECIFIED:		DWN: Y. YIN 05NOV2013		CHK: G. BAILEY 05NOV2013		APVD: H. GUO 05NOV2013		NAME: TE Connectivity Harrisburg, PA 17105-3608	
mm	0 PLC ±0.5	1 PLC ±0.5	2 PLC ±0.13	3 PLC ±0.013	4 PLC ±0.0013	PRODUCT SPEC:		APPLICATION SPEC:		SIZE: CAGE CODE: DRAWING NO: RESTRICTED TO:	
MATERIAL:	FINISH:	ANGLES:		WEIGHT:		A1 00779 ©=2150396		SCALE: 1:1		SHEET 4 OF 4 REV A1	
Customer Accessible Production Drawing										Customer Accessible Production Drawing	