

TOP VIEW

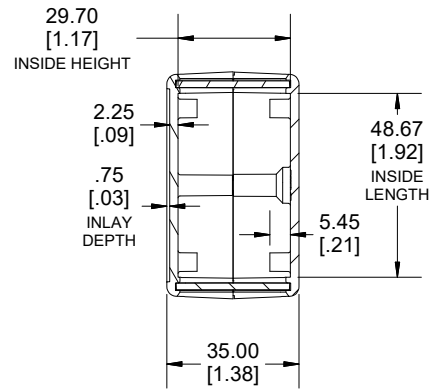

SECTION B-B

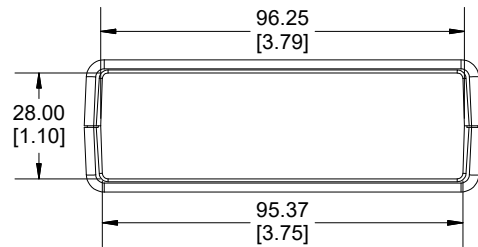
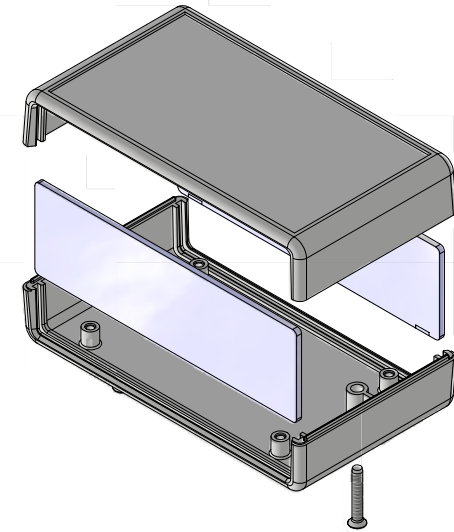

END VIEW

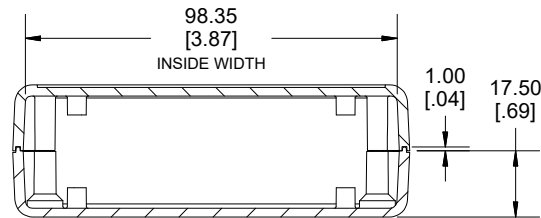

SECTION A-A

Enclosures can be Factory Modified (Milling, Drilling, Printing etc.)
 Contact Factory (modshop@hammfg.com) for quotes
 Solid models of this enclosure available in .stp or .x_t
 (Part number and text placement/orientation on our products are subject to change,
 we do not recommend using them as a locating reference for modification purposes)

NOTE	
Enclosure molded from GP ABS (UL94-HB) plastic. Purchased assembly includes top and bottom cover, 2 flat panels for front and rear and 2 cover screws.	
Recommended Torque: Cover screws - 40 cN-m [57 ozf-in] Internal mounting screws - 20-30 cN-m [29-42 ozf-in]	

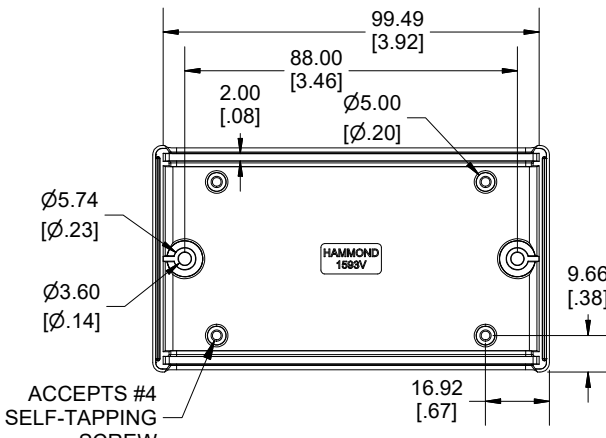

INSIDE BOTTOM

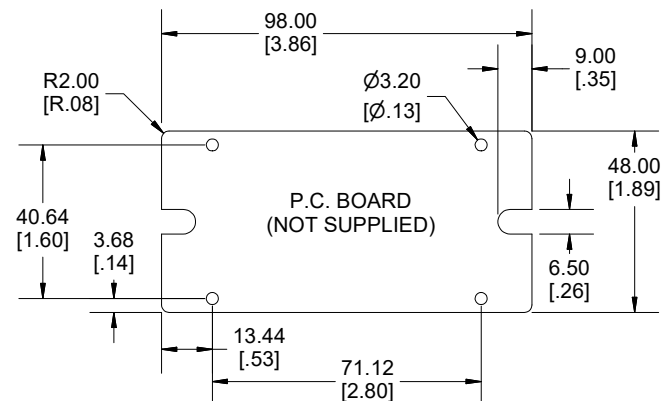

Dimensions:
mm
[inches]

1593		
1593V Regular Enclosure		
Black Enclosure	1593VBK	
Grey Enclosure	1593VGY	
Translucent Blue Enclosure	1593VTBU	
ACCESSORIES		
Cover Screws #4 X 3/4" Self-Tapping (100 Pkg)	1593QS100 (Silver)	
	1593QS100BK (Black)	
P.C. Board Screws #4 X 1/4" Self-Tapping	1593ATS50 (Pkg 50)	
	1593ATS100 (Pkg 100)	
Nylon Belt Clip	1599CLIP (Black)	
	1599CLIPGY (Grey)	
1593V STD FLAT PANEL (Pkg 10)	Black	1593VLBK-10
	Grey	1593VLGY-10
	Translucent Blue	1593VLTBU-10
	Aluminum	1593VAL10

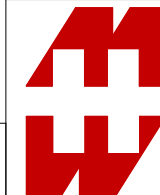

**HAMMOND
MANUFACTURING®**

1593V

www.hammondmfg.com