

### Features

- Frequency range : 10MHz to 52MHz
- SMD seam sealing ceramic package
- Supply voltage : 3.3V
- Free Run Stability for 20 Years :  
±4.6ppm (Stratum 3)
- Clipped Sinewave output
- Voltage control function available
- Tri-state function available
- External dimensions (mm)  
L : 5.0 x W : 3.2 x H : 2.1
- RoHS compliant & Pb free

### Applications

- Wireless communications,  
Smallcell, Base station
- Precise timing & synchronization  
network (IEEE1588, Sync.E),  
OTN, PTN, Switch
- Test and measurement equipment
- Smart grid
- Stratum 3

### Electrical Characteristics

Item		QTS532	Conditions
Nominal Frequency Range (F <sub>0</sub> )		10MHz ~ 52MHz	
Frequency Tolerance (F <sub>tol</sub> )		±2.0 ppm Max.	Note [1]
Frequency Stability	vs Temperature	±0.1ppm, ±0.28ppm, ±0.5ppm	Note [2]
	vs Load	±0.1 ppm Max.	Load ±5%
	vs Supply Voltage	±0.1 ppm Max.	V <sub>DD</sub> ±5%
Operating Temperature Range (T <sub>OTR</sub> )		-40°C ~ +85°C	
Supply Voltage (V <sub>DD</sub> )		3.3V	
Current Consumption (I <sub>DD</sub> )		5.0 mA Max.	
Output Type		Clipped Sinewave	
Output Load		10kΩ // 10pF	
Output Level		0.8 V(p-p) Min.	Note [3]
Tri-state Input	High (output enable)	80% V <sub>DD</sub> Min.	
	Low (output disable)	20% V <sub>DD</sub> Max.	
Start-up Time		2.5 ms Max.	
Auto Frequency Control (AFC) Range		±5ppm ~ ±16ppm	VCTCXO, optional V <sub>C</sub> = 1.5±1.0V
Phase Noise		-135 dBc/Hz Typ.	at 1kHz offset
Aging (F <sub>aging</sub> )		±1 ppm Max.	at 25°C, first year
24 Hours Holdover Stability		±40 ppb Max.	Note [4]
Free Run Stability for 20 Years		±4.6 ppm Max.	Note [5]
Storage Temperature Range (T <sub>STR</sub> )		-55°C ~ +125°C	

**Notes:**

- [1] Refer to nominal frequency, operation after 2 times of reflow at 25°C.
- [2] Refer to  $(F_{max} + F_{min})/2$ .
- [3] Decoupling capacitor is required in external circuit.
- [4] 24 hours at constant temperature after 48 hours operation
- [5] Inclusive of initial tolerance at 25°C, variations over temperature, supply voltage, load, reflow soldering and aging for 20 years.

**Dimensions**

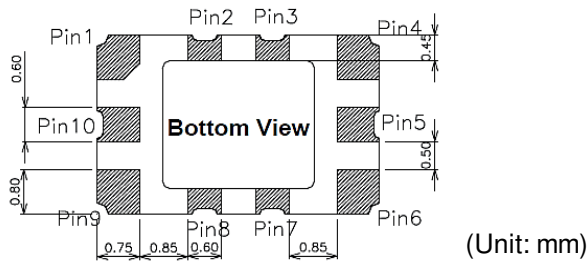
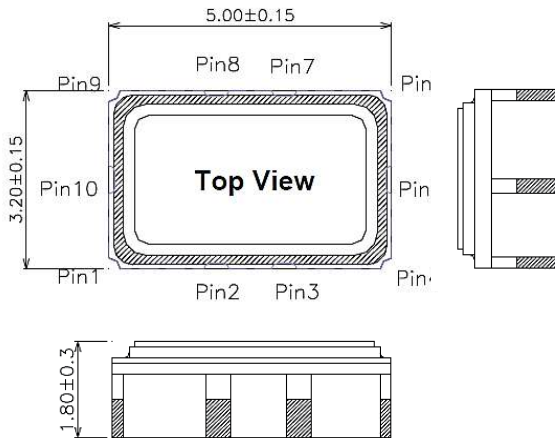

Pin	Pin function	
	TCXO	VCTCXO
Pin 1	GND or NC	AFC
Pin 2	Do not connection	
Pin 3	Tri-state	
Pin 4	GND	
Pin 5	Do not connection	
Pin 6	OUTPUT	
Pin 7	Do not connection	
Pin 8	Do not connection	
Pin 9	$V_{DD}$	
Pin 10	Do not connection	

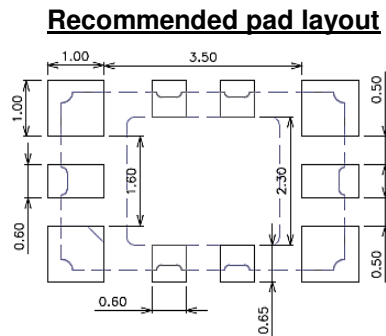

**Ordering Information**

**QTS532 - 19.200M B P - T**

**Frequency in Hz**  
Please contact us for available frequencies

**Supply Voltage**  
B 3.3 V

**Packaging Method**  
T Tape & Reel

**Frequency Stability (over Temp.)**

F	± 0.5 ppm	(-40°C ~ +85°C),	VCTCXO
G	± 0.5 ppm	(-40°C ~ +85°C),	TCXO
O	± 0.28 ppm	(-40°C ~ +85°C),	VCTCXO
P	± 0.28 ppm	(-40°C ~ +85°C),	TCXO
T	± 0.1 ppm	(-40°C ~ +85°C),	VCTCXO
U	± 0.1 ppm	(-40°C ~ +85°C),	TCXO

### Packing

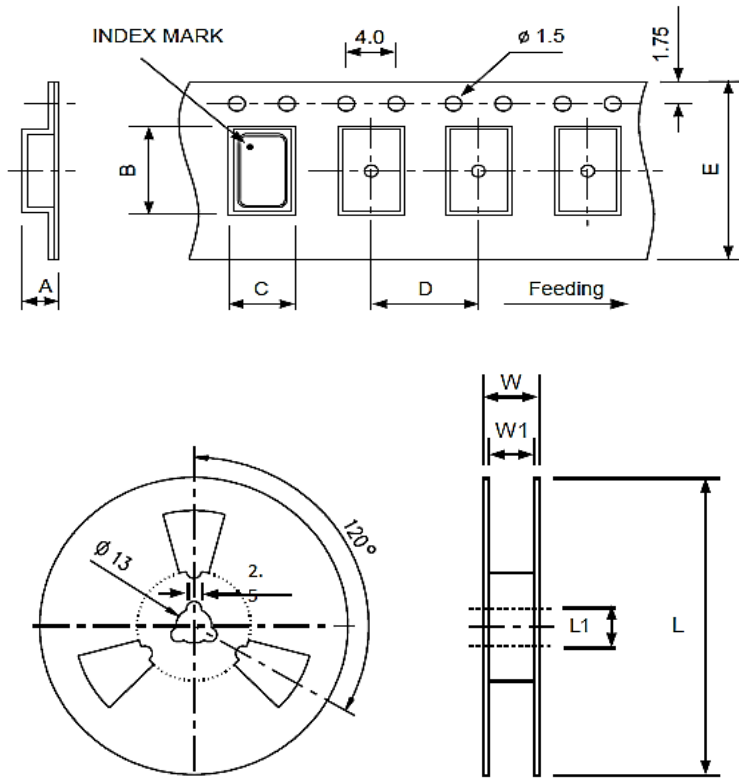

DIMENSIONS (mm)	A	B	C	D	E	L	L1	W	W1
	2.20	5.30	3.50	8.00	12.00	178	17.3	16.1	13.5

(Unit: mm)

### Reflow Profile

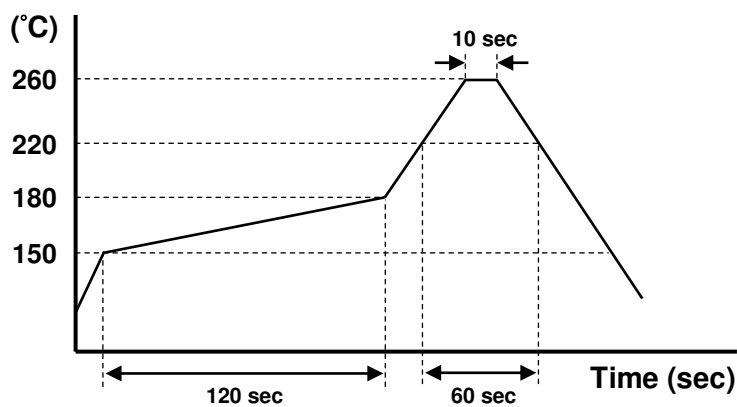

#### Notes:

- [1] Period while temperature exceeds the solder melting point 220°C should be less than 200 sec.
- [2] Period while temperature stays at the top melting point 260°C should be less than 30 sec.