

8

7

6

5

4

3

2

1

VICOR CONFIDENTIAL

THIS DOCUMENT AND THE DATA DISCLOSED HEREIN OR HEREWITH IS NOT TO BE REPRODUCED, USED OR DISCLOSED IN WHOLE OR IN PART TO ANYONE WITHOUT THE PERMISSION OF VICOR CORP.

REV.	DESCRIPTION	INTL	DATE	APVD
1	RELEASED PER E050350	LEK	11/16/05	EF
2	REVISED PER E100841	KUK	06/22/10	GCK
3	REVISED PER E131632	GCK	11/21/2013	TO

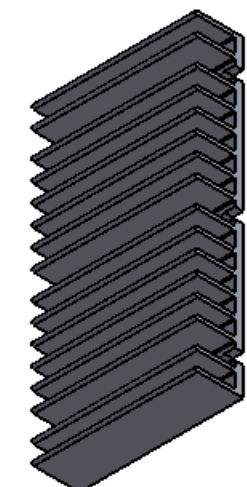
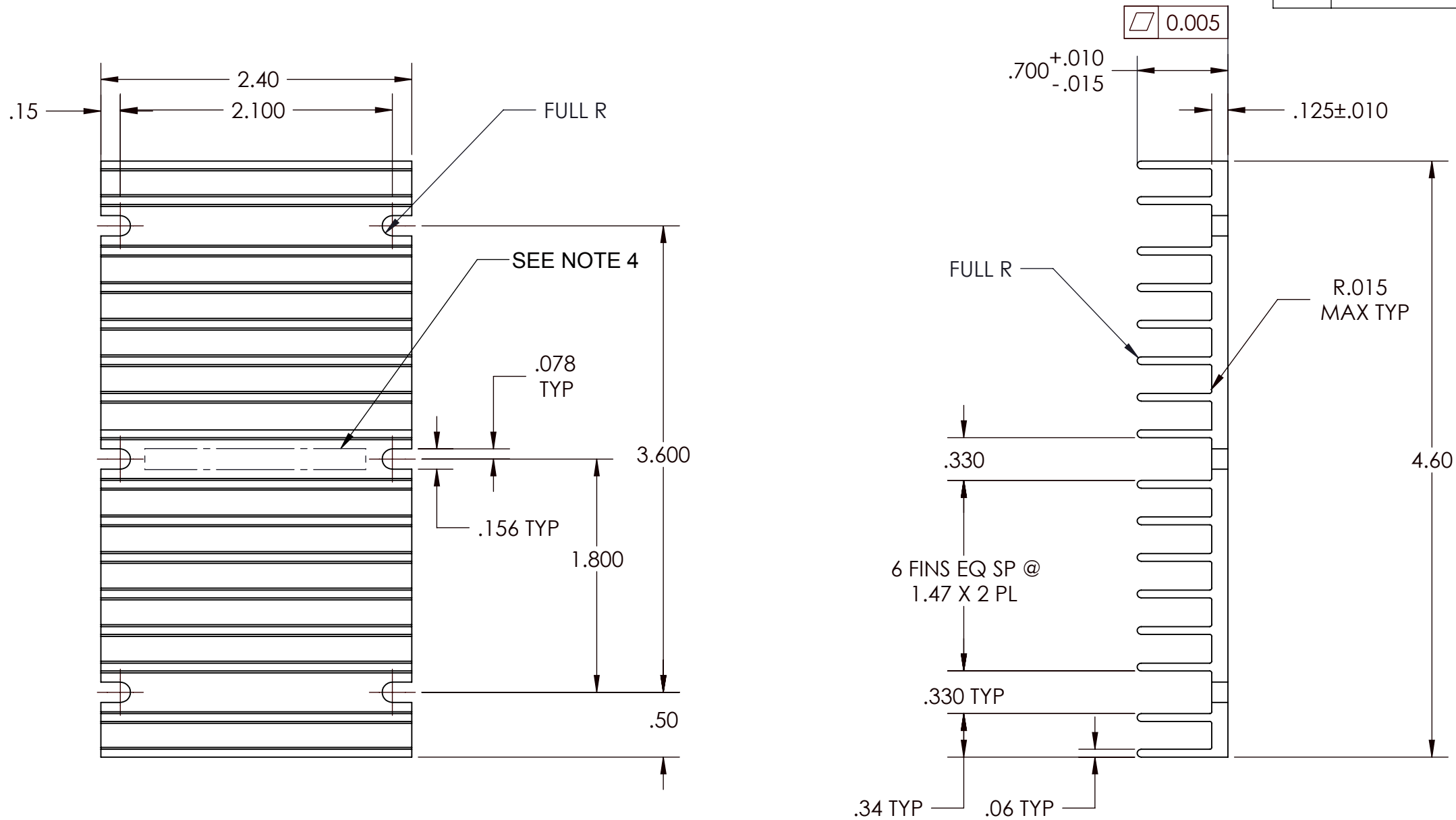

NOTES:

1. MATERIAL: AL. 6063-T5.
2. REMOVE ALL LOOSE AND HANGING BURRS. OTHERWISE, BURRS SHALL NOT EXCEED .003.
- <> 3. CLEAR FINISH RoHS COMPLIANT PER CST-0001, LATEST REVISION PER: A) CHROMIUM FREE OR B.) TRIVALENT CHROMIUM IN ACCORDANCE WITH MIL-D-5541 TYPE II, CLASS 1A OR 3. SEE CST-0003 FOR TYPES OF AVAILABLE FINISHES.
4. MECHANICALLY STAMP OR USE WHITE OR BLACK EPOXY INK FOR PART NUMBER.
5. <> DENOTES CRITICAL CHARACTERISTIC FOR LOT INSPECTION.
6. TOLERANCE ON ALL DIMENSIONS SHOWN AS REFERENCE SHALL FOLLOW STANDARD ALUMINUM ASSOCIATION TOLERANCE.

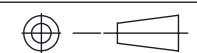
DRAWN BY	DATE			SWD	
Krishna Kamath	05/14/2010				
UNLESS OTHERWISE SPECIFIED DIMENSIONS ARE : INCH / [MM]		HS XF 17.78MM			
TOLERANCES ARE: DECIMALS ANGLES X.XX [X.X] = ±0.01 [0.25] ±1° X.XXX [X.XX] = ±0.005 [0.127]					
THIRD ANGLE PROJECTION		SIZE	CAGE CODE	DWG NO	REV
 DO NOT SCALE DRAWING		B	67131	30193	3
		SCALE 1:1	SHEET 1 OF 1		

8

7

6

5

4

3

2

1