

Analog Displacement Sensors for Transportation Applications



FEATURES

- Conductive plastic potentiometer technology
- Use in engine compartment
- Lever drive with return spring
- Wire outputs
- Material categorization: for definitions of compliance please see www.vishay.com/doc?99912

RoHS
COMPLIANT

LINKS TO ADDITIONAL RESOURCES



QUICK REFERENCE DATA	
Sensor type	ROTATIONAL, conductive plastic
Output type	Output by wires
Market appliance	Transportation
Dimensions	39.2 mm (or 42 mm, or 47 mm) x 31.5 mm (or 34.2 mm) x 23.37 mm

ELECTRICAL SPECIFICATIONS	
PARAMETER	
Total electrical travel	94° ± 2°
Independent linearity standard	± 1.5 %
Total resistance (R _n)	3.85 kΩ ± 20 %
Output smoothness	< 0.1 % (NFC 93255)
Power rating at +40 °C	0.5 W
Power rating at +125 °C	0.05 W
Wiper current limiting resistance (R _w)	1.7 kΩ ± 20 %
Recommended wiper current	< 100 μA
Maximum wiper current	15 mA for 1 min
Recommended load impedance	≥ 100 R _n

MECHANICAL SPECIFICATIONS	
PARAMETER	
Mechanical travel	125° ± 4°
Lever return torque at start of travel	≥ 1 N cm
Lever return torque at end of travel	≤ 10 N cm
Stop strength	60 N cm
Lever return	Counterclockwise
Protection class	See "Specific Characteristics" table
Mounting screw tightening torque	1.2 N m maximum

PERFORMANCE	
PARAMETER	
Operating temperature range	-40 °C to +125 °C
Storage temperature range	-55 °C to +135 °C
Vibrations	Severity 10 Hz to 2000 Hz, 10 mm or 50 g
Life	See "Specific Characteristics" table
Micro-movements (dither stroke)	> 50M cycles



SAP PART NUMBERING GUIDELINES						
MODEL	TYPE	LEVER TYPE	VALUE	ANGLE	LEADS	PACKAGING
PMR4	03	A = lever A C = lever C	392 = 3K9	094	W = wire	C = 20 pcs G = 100 pcs P = 500 pcs
	23					
	02					
	22					
	04					
	24					
	01					
	21					
	11					
	31					
	12					
	16					
	26					
	18					
	28					
	(see "Specific Characteristics")					

SPECIFIC CHARACTERISTICS				
SENSOR TYPE	LIFE		PROTECTION CLASS	PACKAGE TYPE ⁽¹⁾
	MICRO-MOVEMENTS (dither stroke)	NUMBER OF CYCLES ELECTRICAL TRAVEL		
403	10 x 10 ⁶	5 x 10 ⁶	IP64	1
423	10 x 10 ⁶	5 x 10 ⁶	IP64	2
402	10 x 10 ⁶	5 x 10 ⁶	IP64	3
422	10 x 10 ⁶	5 x 10 ⁶	IP64	4
404	10 x 10 ⁶	5 x 10 ⁶	IP66	1
424	10 x 10 ⁶	5 x 10 ⁶	IP66	2
401	10 x 10 ⁶	5 x 10 ⁶	IP66	3
421	10 x 10 ⁶	5 x 10 ⁶	IP66	4
411	50 x 10 ⁶	5 x 10 ⁶	IP64	1
431	50 x 10 ⁶	5 x 10 ⁶	IP64	2
412	50 x 10 ⁶	5 x 10 ⁶	IP64	3
416	50 x 10 ⁶	5 x 10 ⁶	IP66	1
426	50 x 10 ⁶	5 x 10 ⁶	IP66	2
418	50 x 10 ⁶	5 x 10 ⁶	IP66	3
428	50 x 10 ⁶	5 x 10 ⁶	IP66	4

Notes

- Nothing stated herein shall be construed as a guarantee of quality or durability.

⁽¹⁾ Package types

- 1: Little ears Fixation: 2 screws M4 with Ø: 31.5 mm
- 2: Little tightened ears Fixation: 2 screws M4 with Ø: 31.5 mm
- 3: Big ears Fixation: 2 screws M4 with Ø: 34 mm
- 4: Big tightened ears Fixation: 2 screws M4 with Ø: 34 mm

LEVER OPTIONS

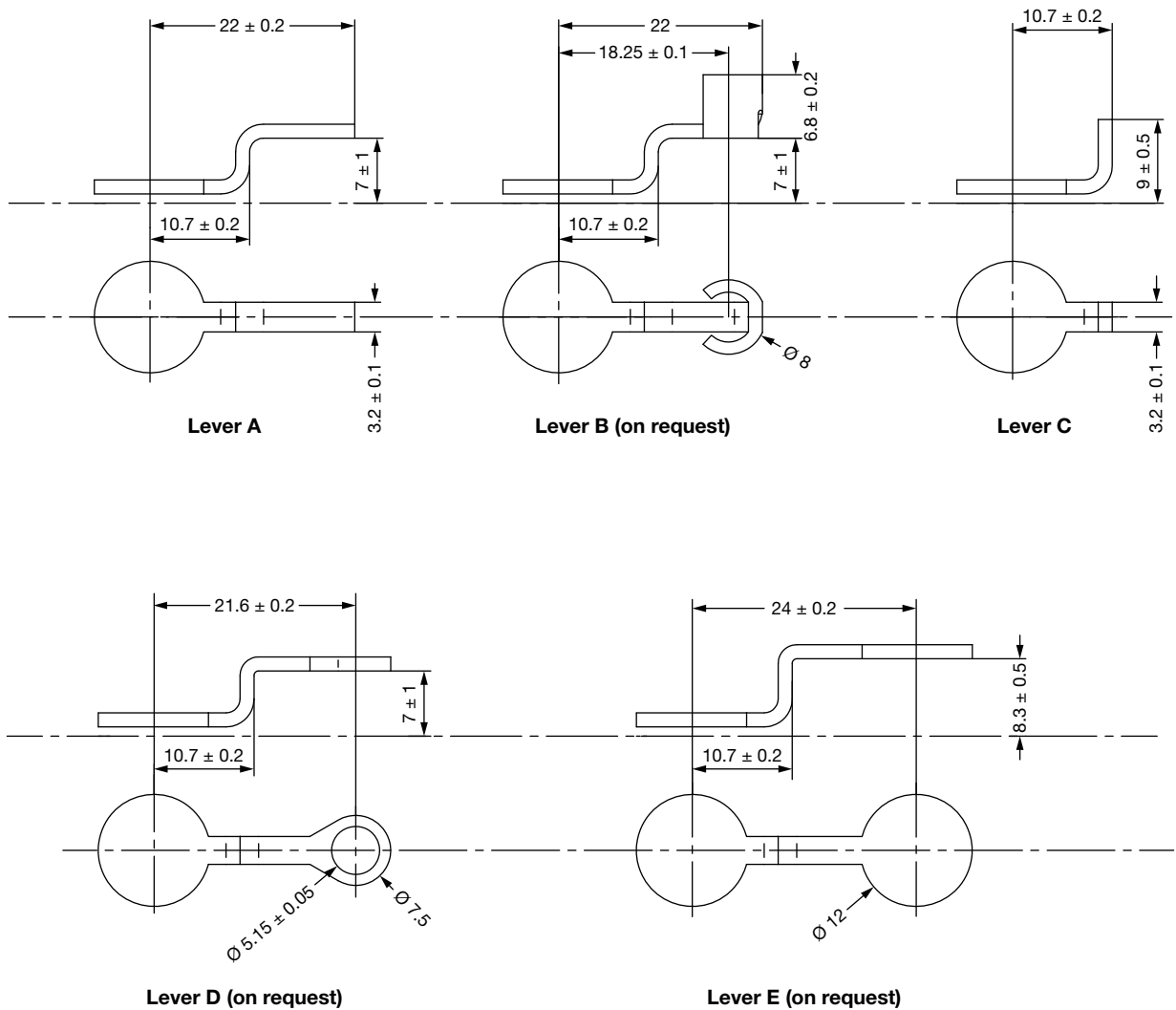

CONNECTIONS

Wire Outputs: -40 °C to +105 °C (3 x 0.93 mm² length 300 mm)
Sheathed Wire Outputs: -40 °C to +125 °C optional

DIMENSIONS in millimeters

PACKAGE TYPE 1 (FOR SENSOR TYPES 403, 404, 411, AND 416)

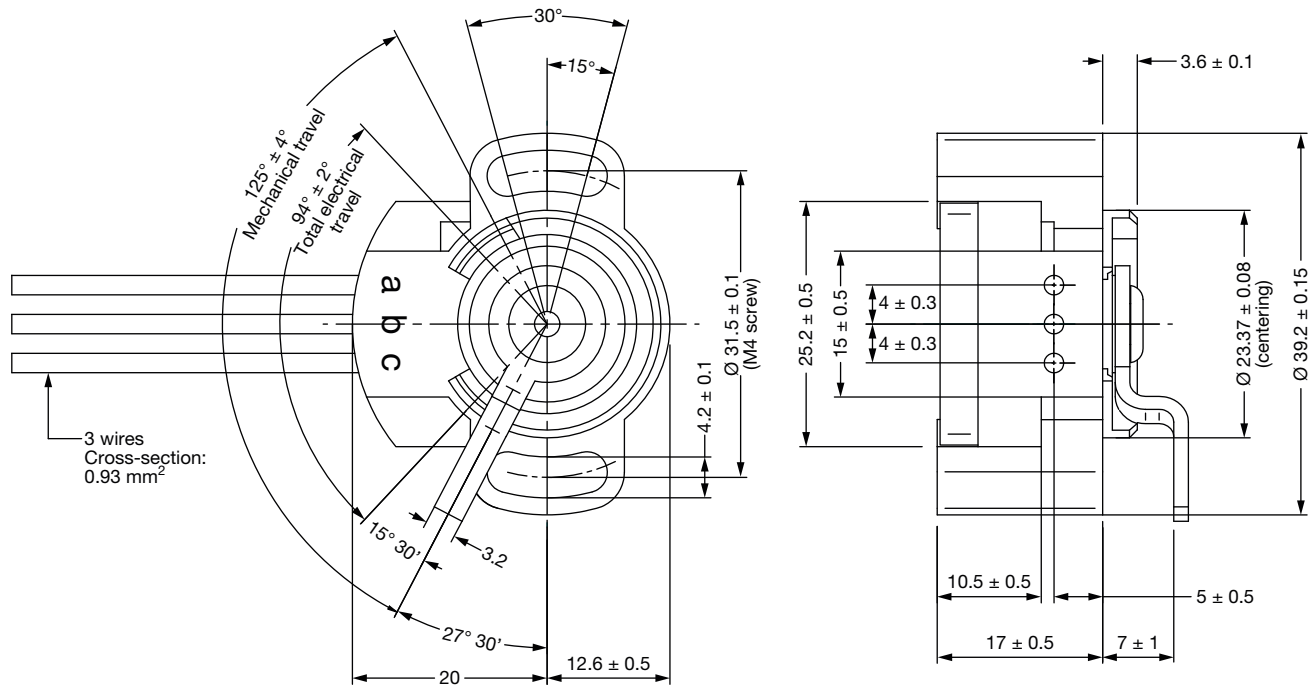

PACKAGE TYPE 2 (FOR SENSOR TYPES 423, 424, 426, AND 431)

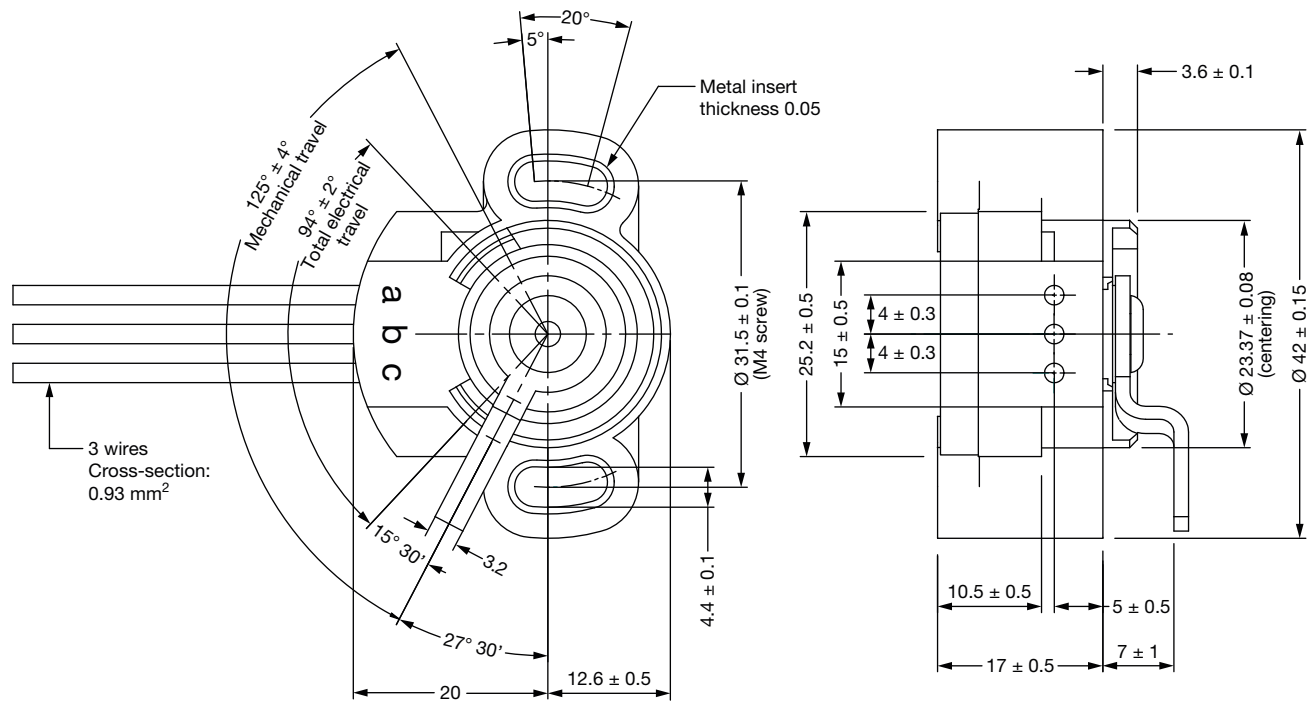

DIMENSIONS in millimeters

PACKAGE TYPE 3 (FOR SENSOR TYPES 401, 402, 412, AND 418)

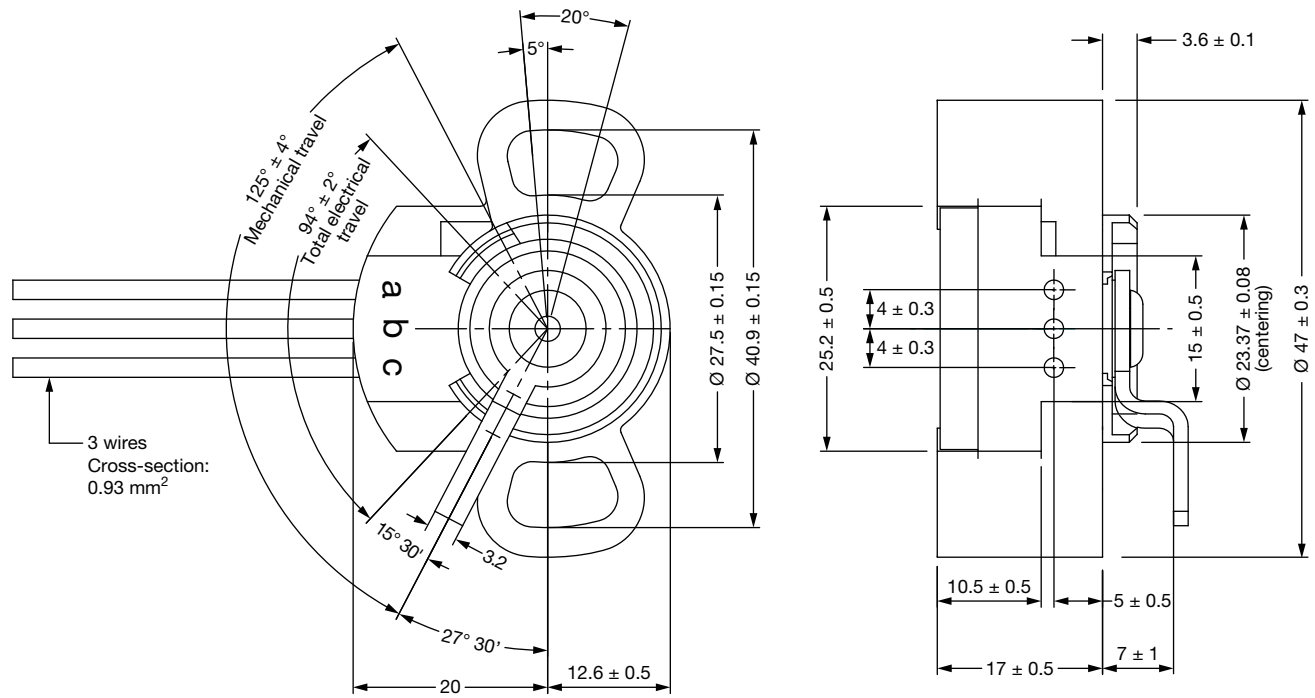

PACKAGE TYPE 4 (FOR SENSOR TYPES 421, 422, AND 428)

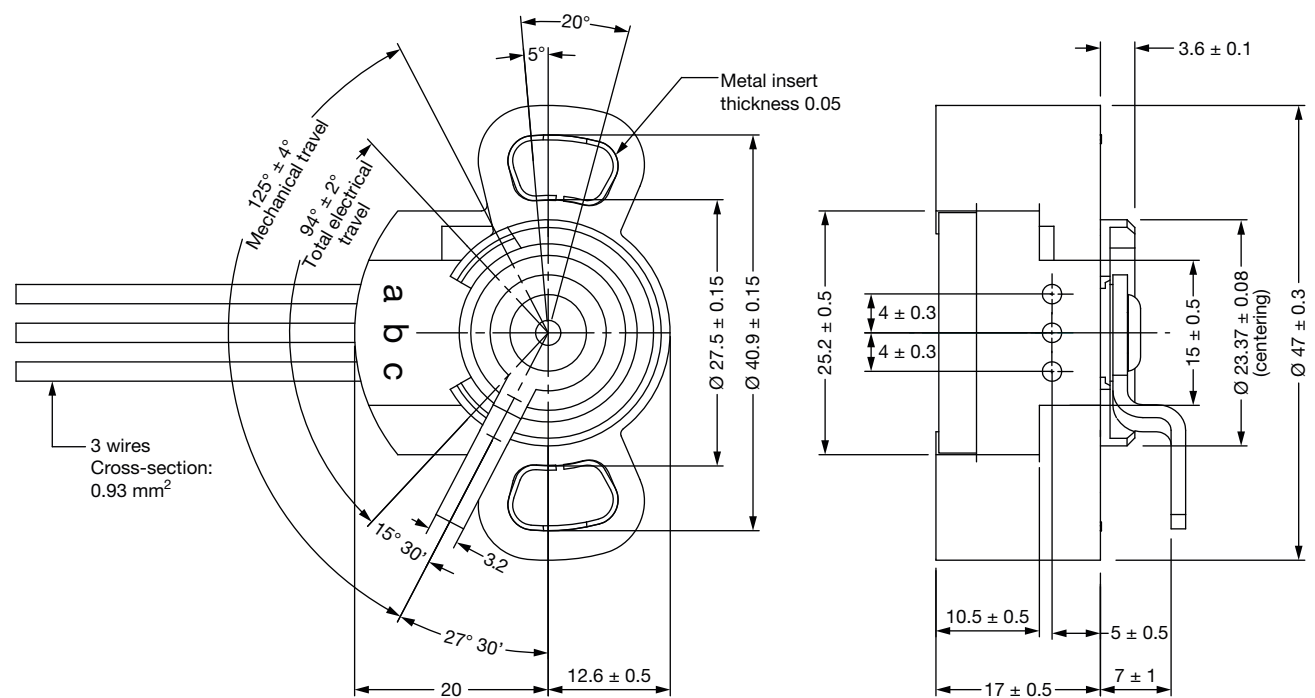

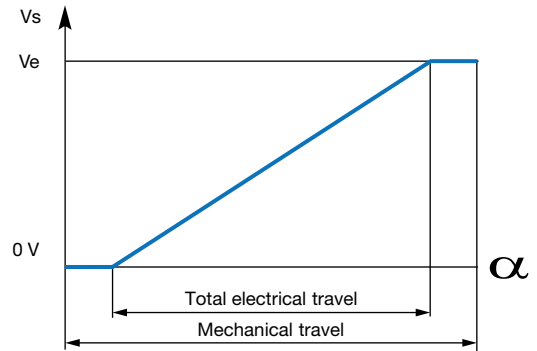
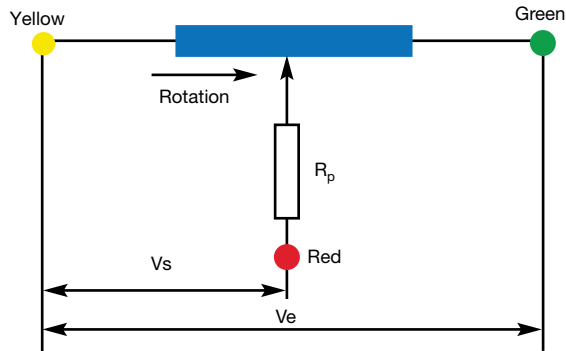
ELECTRICAL DIAGRAM

OPTIONS (on request)

- Other total electrical travel
- Other resistance values
- Other linearity
- No protection resistance (R_p)
- High temperature sheathed wire outputs
- Specific connections
- Clockwise spring lever direction
- Other lever



Disclaimer

ALL PRODUCT, PRODUCT SPECIFICATIONS AND DATA ARE SUBJECT TO CHANGE WITHOUT NOTICE TO IMPROVE RELIABILITY, FUNCTION OR DESIGN OR OTHERWISE.

Vishay Intertechnology, Inc., its affiliates, agents, and employees, and all persons acting on its or their behalf (collectively, "Vishay"), disclaim any and all liability for any errors, inaccuracies or incompleteness contained in any datasheet or in any other disclosure relating to any product.

Vishay makes no warranty, representation or guarantee regarding the suitability of the products for any particular purpose or the continuing production of any product. To the maximum extent permitted by applicable law, Vishay disclaims (i) any and all liability arising out of the application or use of any product, (ii) any and all liability, including without limitation special, consequential or incidental damages, and (iii) any and all implied warranties, including warranties of fitness for particular purpose, non-infringement and merchantability.

Statements regarding the suitability of products for certain types of applications are based on Vishay's knowledge of typical requirements that are often placed on Vishay products in generic applications. Such statements are not binding statements about the suitability of products for a particular application. It is the customer's responsibility to validate that a particular product with the properties described in the product specification is suitable for use in a particular application. Parameters provided in datasheets and / or specifications may vary in different applications and performance may vary over time. All operating parameters, including typical parameters, must be validated for each customer application by the customer's technical experts. Product specifications do not expand or otherwise modify Vishay's terms and conditions of purchase, including but not limited to the warranty expressed therein.

Hyperlinks included in this datasheet may direct users to third-party websites. These links are provided as a convenience and for informational purposes only. Inclusion of these hyperlinks does not constitute an endorsement or an approval by Vishay of any of the products, services or opinions of the corporation, organization or individual associated with the third-party website. Vishay disclaims any and all liability and bears no responsibility for the accuracy, legality or content of the third-party website or for that of subsequent links.

Except as expressly indicated in writing, Vishay products are not designed for use in medical, life-saving, or life-sustaining applications or for any other application in which the failure of the Vishay product could result in personal injury or death. Customers using or selling Vishay products not expressly indicated for use in such applications do so at their own risk. Please contact authorized Vishay personnel to obtain written terms and conditions regarding products designed for such applications.

No license, express or implied, by estoppel or otherwise, to any intellectual property rights is granted by this document or by any conduct of Vishay. Product names and markings noted herein may be trademarks of their respective owners.