2.4 GHz High-Gain, High-Efficiency Power Amplifier

Features

- High Gain:
 - Typically 39 dB gain across 2.4–2.5 GHz over temperature -20°C to +85°C
- High linear output power:
 - >30 dBm P1dB
 - Please refer to “[Absolute Maximum Stress Ratings](#)” on page 5
 - Meets 802.11g OFDM spectrum mask requirement up to 28 dBm
 - Typically 25 dBm with <3% EVM, 802.11g, 54 Mbps, 350 mA current
 - Typically 24 dBm with <2.5% EVM, 802.11n, MCS7-HT20, 50% duty cycle
 - Typically 23 dBm with <1.75% EVM, MCS9-HT40, 50% duty cycle, 320 mA current
 - Meets 802.11b ACPR requirement up to 28 dBm with 30% power-added efficiency
- High-speed power-up/down
 - Turn on/off time (10%-90%) <100 ns
- 10:1 VSWR survivability (unconditionally stable up to 28 dBm)
- On-chip power detection
 - >20 dB dynamic range
 - VSWR- and temperature-insensitive
- Simple input/output matching
- Packages available
 - 16-contact UQFN (3mm x 3mm)
- All non-Pb (lead-free) devices are RoHS compliant

Applications

- WLAN (IEEE 802.11b/g/n)
- WLAN 256 QAM
- AP router
- Home RF
- Cordless phones
- 2.4 GHz ISM wireless equipment

1.0 PRODUCT DESCRIPTION

SST12CP21 is a high-power and high-gain power amplifier (PA) based on the highly-reliable InGaP/GaAs HBT technology.

This PA can be easily configured for high-power applications with high power-added efficiency while operating over the 2.4-2.5 GHz frequency band. It typically provides 39 dB gain with 25% power-added efficiency @ $P_{OUT} = 28$ dBm for 802.11g.

SST12CP21 has excellent linearity, typically 25 dBm at 3% EVM with 54 Mbps 802.11g operation while meeting 802.11g spectrum mask at 28 dBm. SST12CP21 also has a single-ended power detector which lowers the users' cost for power control.

The power amplifier IC also features easy board-level usage along with high-speed power-up/-down control.

SST12CP21 is offered in 16-contact UQFN package. See [Figure 3-1](#) for pin assignments and [Table 4-1](#) for pin descriptions.

TO OUR VALUED CUSTOMERS

It is our intention to provide our valued customers with the best documentation possible to ensure successful use of your Microchip products. To this end, we will continue to improve our publications to better suit your needs. Our publications will be refined and enhanced as new volumes and updates are introduced.

If you have any questions or comments regarding this publication, please contact the Marketing Communications Department via E-mail at docerrors@microchip.com. We welcome your feedback.

Most Current Data Sheet

To obtain the most up-to-date version of this data sheet, please register at our Worldwide Web site at:

<http://www.microchip.com>

You can determine the version of a data sheet by examining its literature number found on the bottom outside corner of any page. The last character of the literature number is the version number, (e.g., DS30000000A is version A of document DS30000000).

Errata

An errata sheet, describing minor operational differences from the data sheet and recommended workarounds, may exist for current devices. As device/documentation issues become known to us, we will publish an errata sheet. The errata will specify the revision of silicon and revision of document to which it applies.

To determine if an errata sheet exists for a particular device, please check with one of the following:

- Microchip's Worldwide Web site; <http://www.microchip.com>
- Your local Microchip sales office (see last page)

When contacting a sales office, please specify which device, revision of silicon and data sheet (include literature number) you are using.

Customer Notification System

Register on our web site at www.microchip.com to receive the most current information on all of our products.

2.0 FUNCTIONAL BLOCKS

FIGURE 2-1: FUNCTIONAL BLOCK DIAGRAM

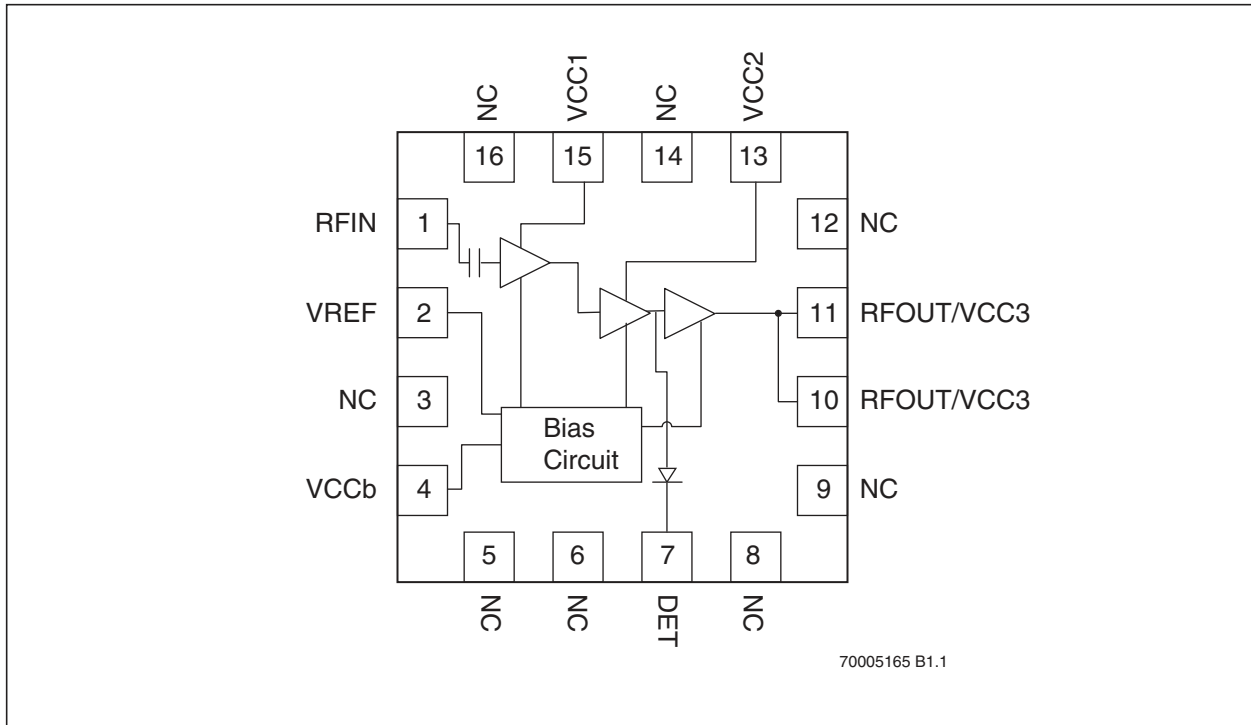

3.0 PIN ASSIGNMENTS

FIGURE 3-1: PIN ASSIGNMENTS FOR 16-CONTACT UQFN

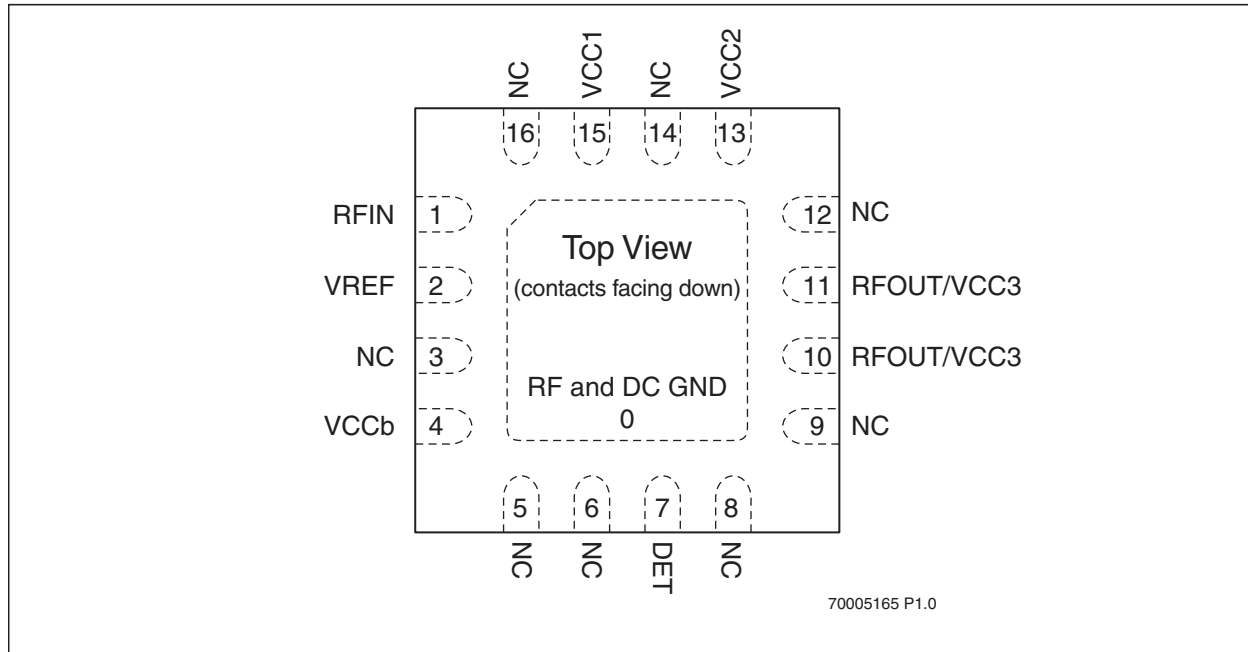

4.0 PIN DESCRIPTIONS

TABLE 4-1: PIN DESCRIPTION

Symbol	Pin No.	Pin Name	Type ¹	Function
GND	0	Ground		The center pad should be connected to RF ground
RFIN	1	RF _{IN}	I	RF input, DC decoupled
VREF	2	V _{REF}	PWR	PA enable and idle-current control
NC	3	No Connection		No Internal Connection
VCCb	4	Power Supply	PWR	Supply voltage for bias circuit
NC	5	No Connection		No Internal Connection
NC	6	No Connection		No Internal Connection
VDET	7	V _{DET}	O	On-chip power detector
NC	8	No Connection		No Internal Connection
NC	9	No Connection		No Internal Connection
RFOUT	10	RF _{OUT}	O	RF output
RFOUT	11	RF _{OUT}	O	RF output
NC	12	No Connection		No Internal Connection
VCC2	13	V _{CC2}	PWR	PWR power supply, 2 nd stage
NC	14	NC		No Internal Connection
VCC1	15	V _{CC1}	PWR	PWR power supply, 1 st stage
NC	16	No Connection		No Internal Connection

1. I=Input, O=Output

5.0 ELECTRICAL SPECIFICATIONS

The DC and RF specifications for the power amplifier are specified below. Refer to [Table 5-2](#) for the DC voltage and current specifications.

Absolute Maximum Stress Ratings (Applied conditions greater than those listed under “Absolute Maximum Stress Ratings” may cause permanent damage to the device. This is a stress rating only and functional operation of the device at these conditions or conditions greater than those defined in the operational sections of this data sheet is not implied. Exposure to absolute maximum stress rating conditions may affect device reliability.)

Input power to pin 1 (P_{IN}) ¹	+12 dBm
Supply voltage at pins 4, 10, 11, 13 and 15 (V_{CC})	+6 V
Reference voltage to pin 2 (V_{REF1})	+3.2 V
DC supply current (I_{CC})	600 mA
Operating Temperature (T_A)	-40°C to +85°C
Storage Temperature (T_{STG})	-40°C to +120°C
Maximum Junction Temperature (T_J)	+150°C
Surface Mount Solder Reflow Temperature	260°C for 10 seconds

1. Maximum input power for $V_{CC} = 5V$ with 50% duty cycle, 802.11g 54 Mbps, with maximum output VSWR = 10:1. At $V_{CC} = 5V$, a 10Ω resistor must be included on V_{CC1} , as shown in [Figures 6-8](#) and [6-9](#).

TABLE 5-1: OPERATING RANGE

Range	Ambient Temp	V_{CC}
Industrial	-20°C to +85°C	5.0V

TABLE 5-2: DC ELECTRICAL CHARACTERISTICS AT 25°C

Symbol	Parameter	Min.	Typ	Max.	Unit
V_{CC}	Supply Voltage	4.0	5.0	5.5	V
I_{CC}	DC Current				
	for 802.11g, 28 dBm		440		mA
	for 802.11b, 28 dBm		440		mA
I_{CQ}	Idle Current		275		mA
V_{REG}	Reference Voltage see Figure 6-8 on page 10	2.9	2.95	3.1	V
I_{REG}	Reference Current		8		mA

TABLE 5-3: AC ELECTRICAL CHARACTERISTICS FOR CONFIGURATION AT $V_{CC} = 5V$, $V_{REF} = 2.95V$, 25°C, 50% DUTY CYCLE

Symbol	Parameter	Min.	Typ	Max.	Unit
F_{L-U}	Frequency range in 802.11b/g applications	2400		2500	MHz
P_{OUT}	Output power at 3% EVM with 802.11g OFDM at 54 Mbps		25		dBm
	Output power at 2.5% EVM with 802.11n MCS7 HT20		24		dBm
	Output power at 1.75% EVM with 256 QAM MCS9 HT40		23		dBm
	Output power meeting 802.11g spectral mask, 6 Mbps		28		dBm
	Output power meeting 802.11n HT20 spectral mask		26		dBm
	Output power meeting MCS9-HT40 spectral mask		26		dBm
	Output power meeting 802.11b spectral mask with 11 Mbps CCK		28		dBm
G	Power gain for 802.11b/g/n/256 QAM	37	39		dB
G_{VAR}	Gain variation over band			±0.5	dB
2f	Second Harmonic at 29 dBm, 802.11b mask compliance ¹		-50		dBm/MHz
3f	Third Harmonic at 29 dBm, 802.11b mask compliance ¹		-50		dBm/MHz

1. See Figure 6-9

6.0 TYPICAL PERFORMANCE CHARACTERISTICS

Test Conditions: $V_{CC} = 5.0V$, $V_{REG} = 2.95V$, $T_A = 25^\circ C$, IEEE 802.11g, 54 Mbps, 50% duty cycle unless otherwise specified

FIGURE 6-1: S-PARAMETER

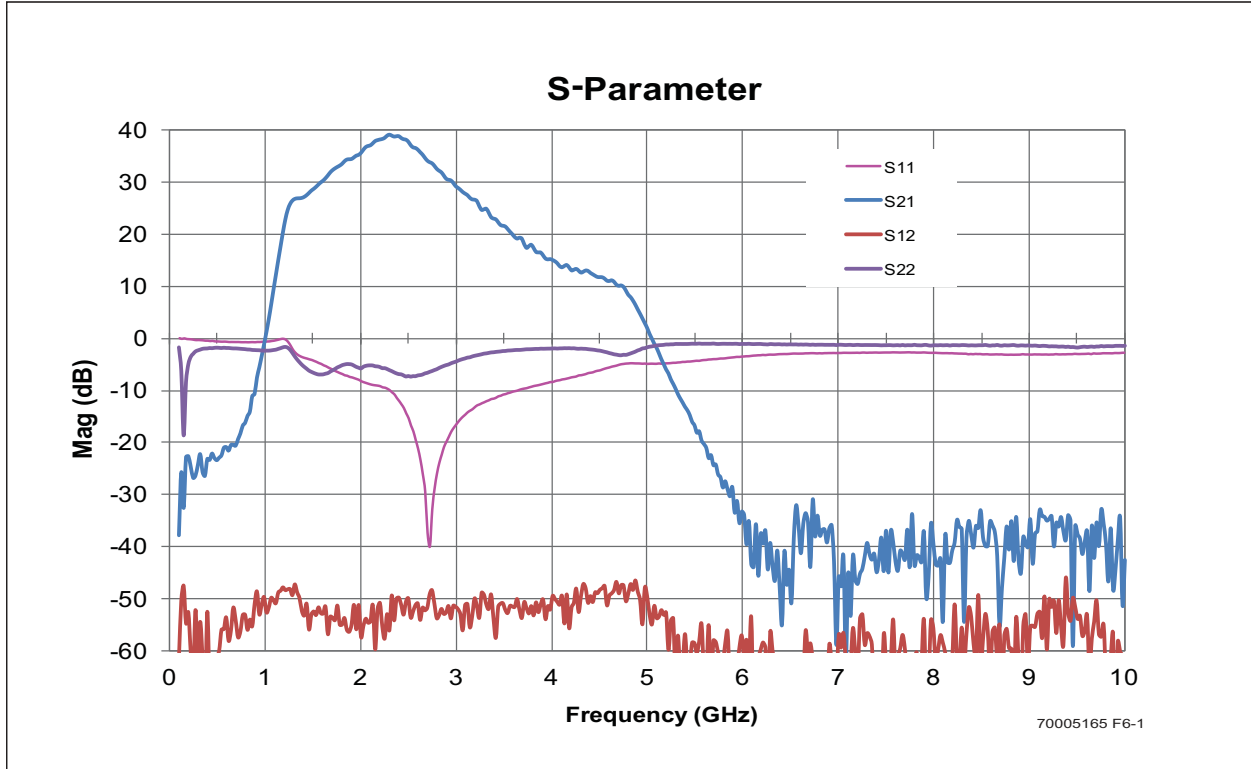

FIGURE 6-2: DYNAMIC EVM VERSUS OUTPUT POWER

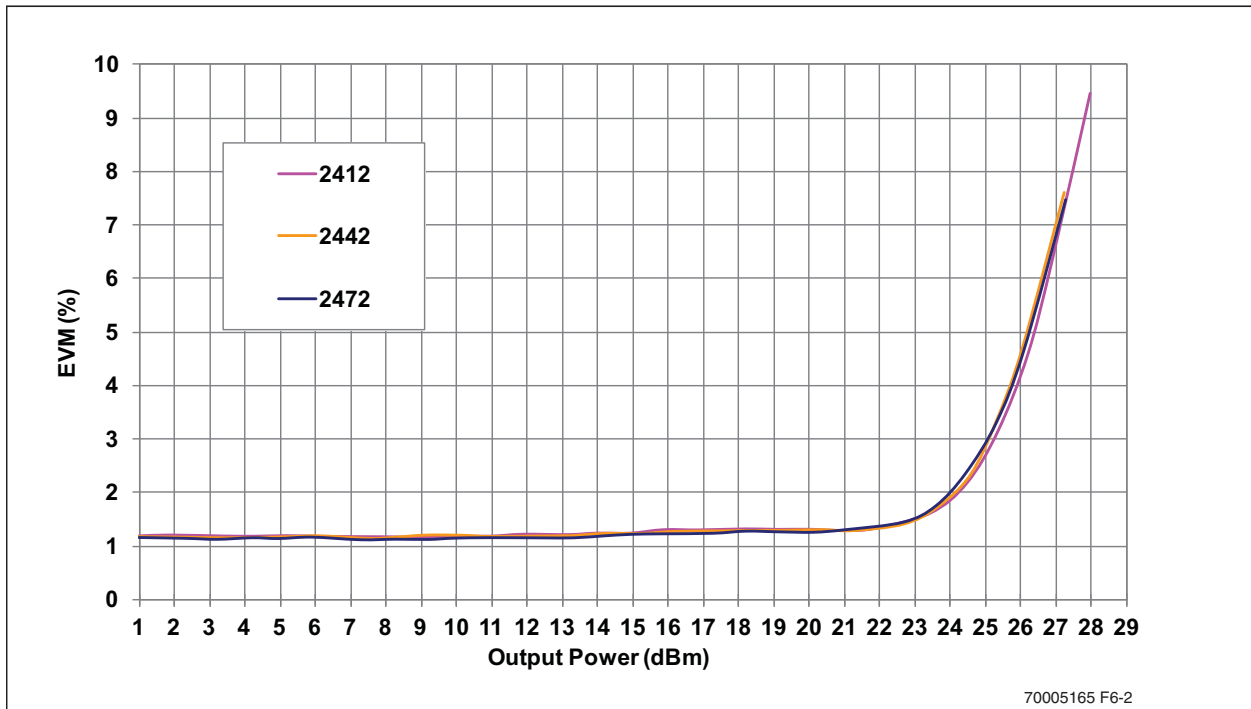

FIGURE 6-3: DYNAMIC EVM VERSUS OUTPUT POWER 802.11AC, MCS0-HT40, 50% DUTY CYCLE

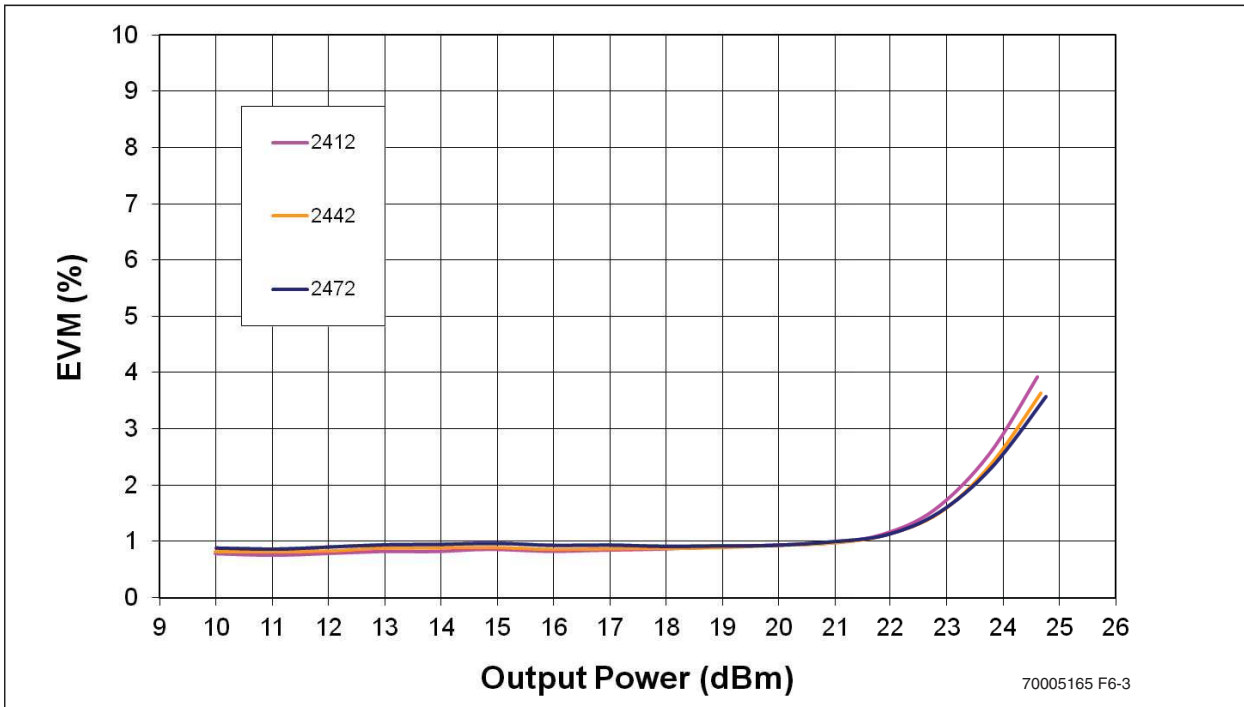

FIGURE 6-4: POWER GAIN VERSUS OUTPUT POWER

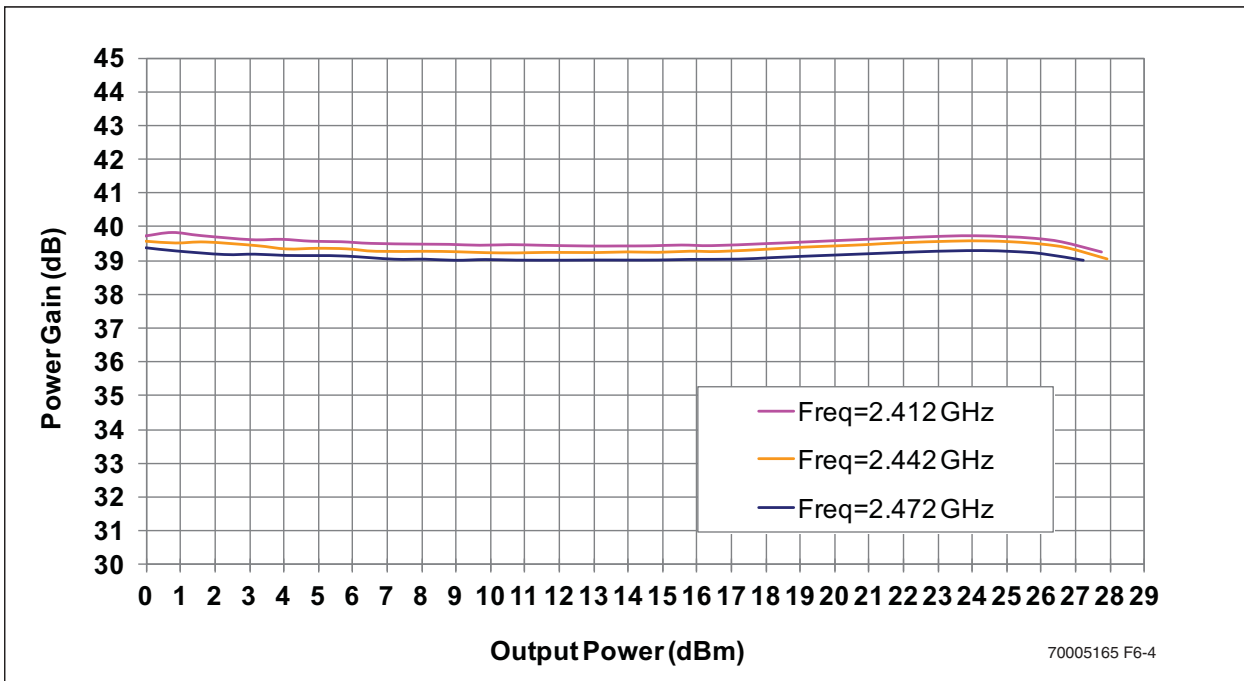

FIGURE 6-5: DC CURRENT VERSUS OUTPUT POWER

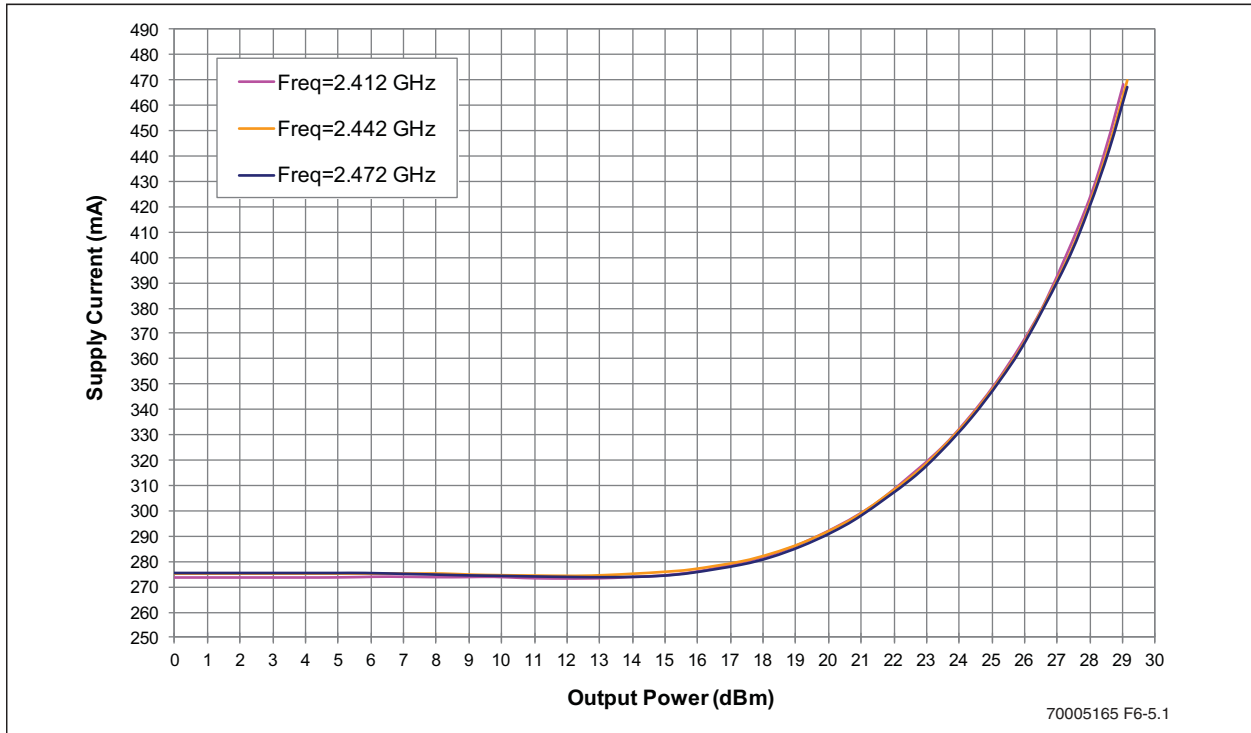

FIGURE 6-6: DETECTOR OUTPUT VOLTAGE VERSUS OUTPUT POWER

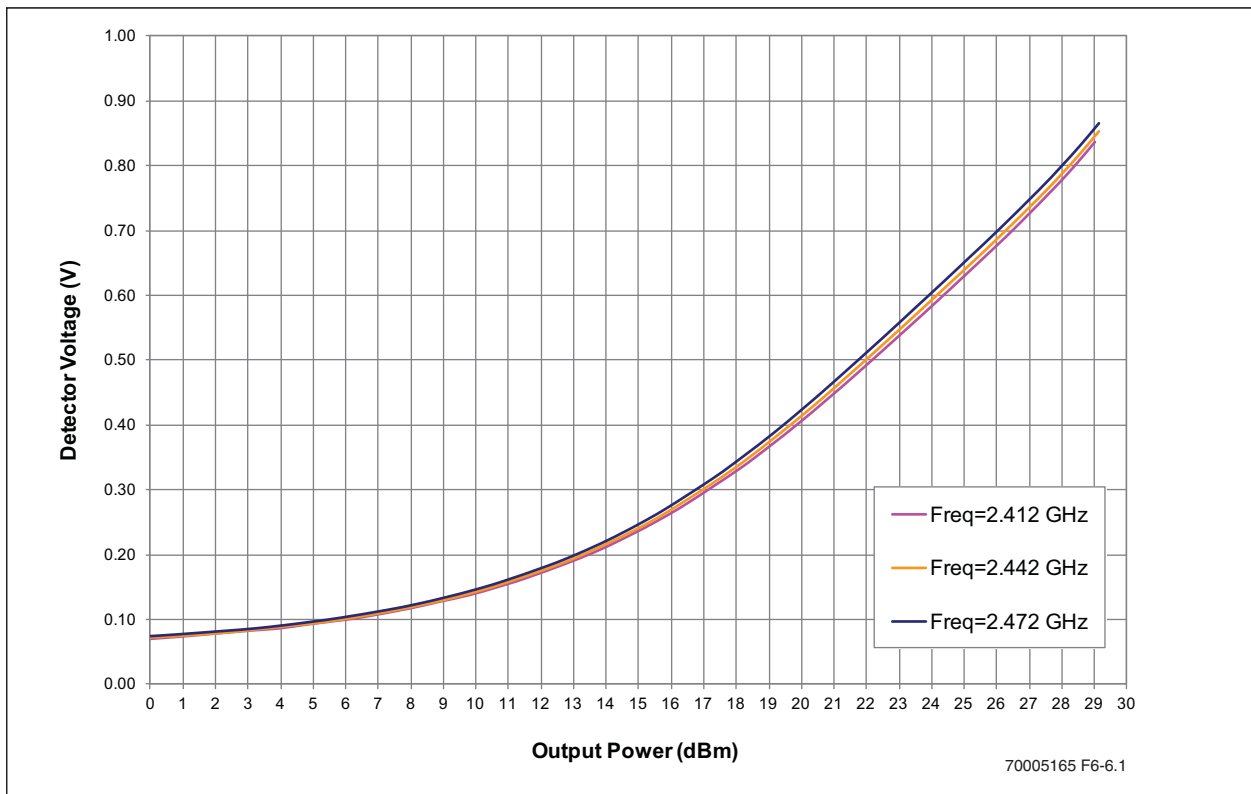

FIGURE 6-7: DYNAMIC EVM VERSUS OUTPUT POWER (WITH HARMONIC FILTER)

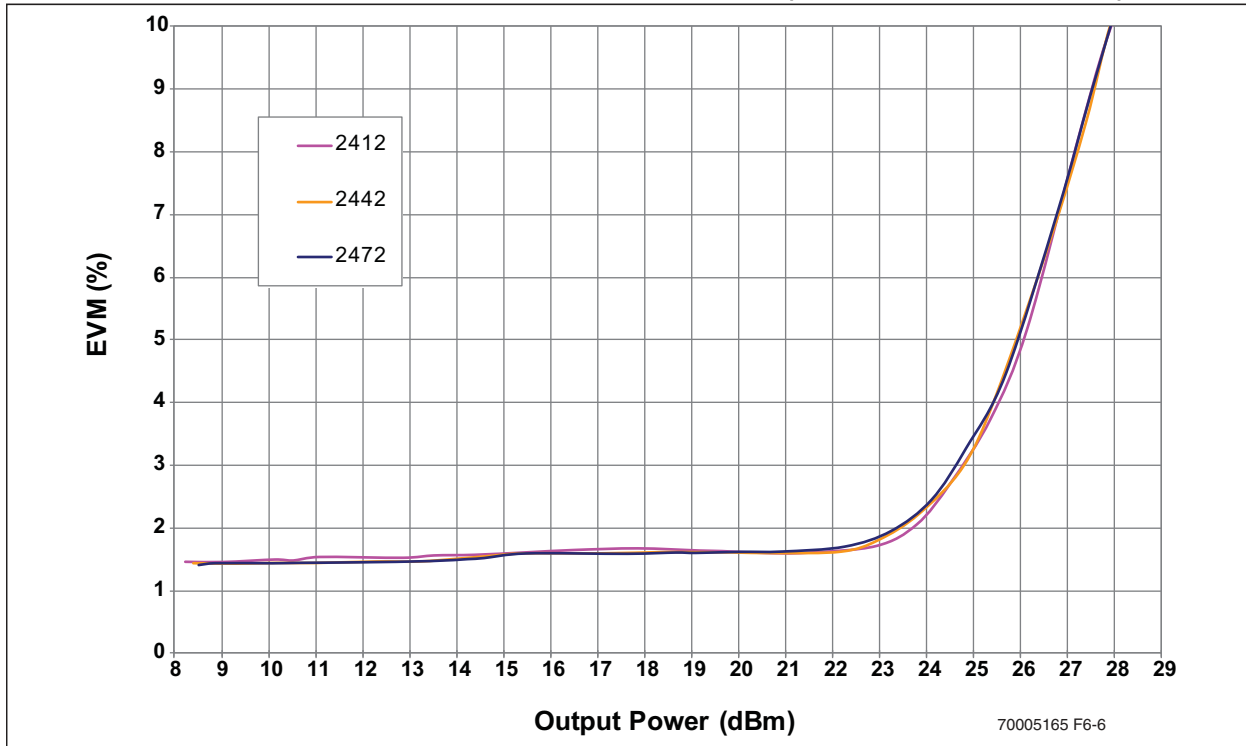

FIGURE 6-8: TYPICAL SCHEMATIC FOR 256 QAM APPLICATIONS

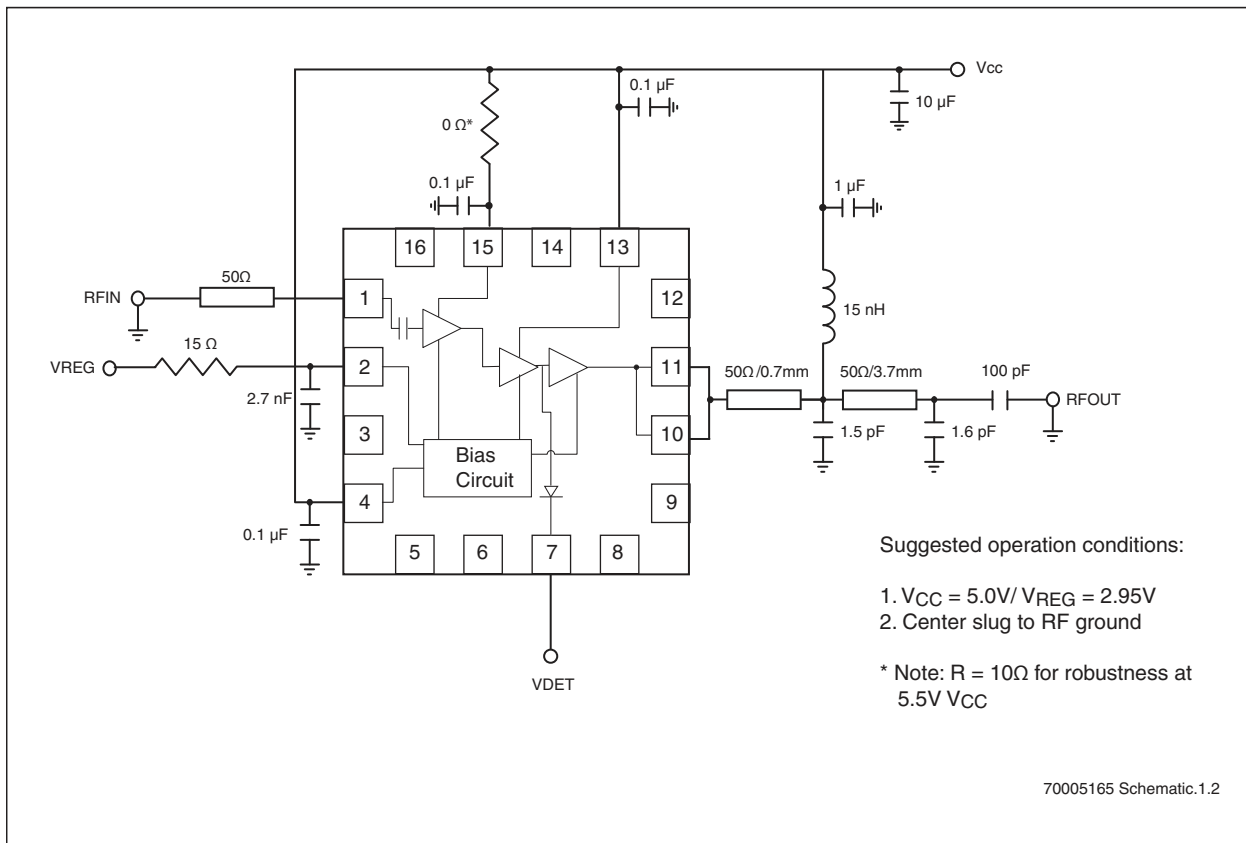
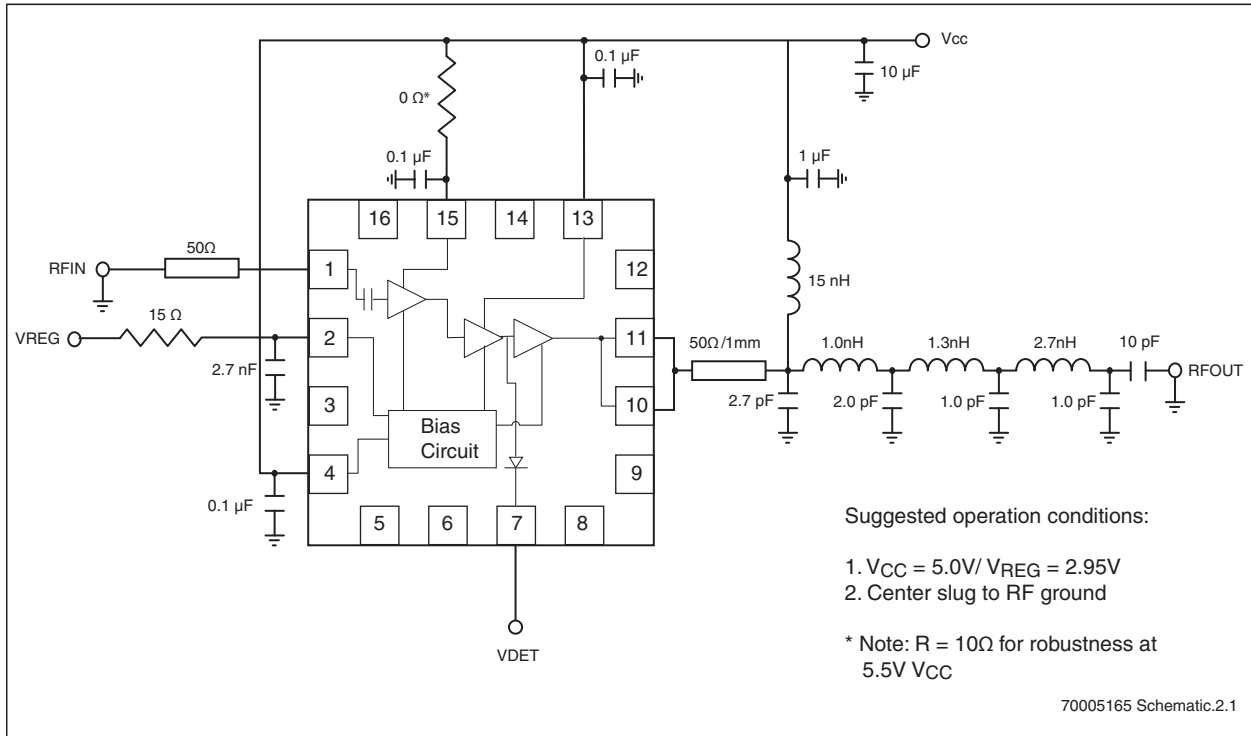

FIGURE 6-9: SCHEMATIC WITH HARMONIC FILTER FOR 256 QAM APPLICATIONS



7.0 PACKAGING DIAGRAMS

16-Lead Ultra Thin Quad Flatpack No-Leads (QUCE/F) - 3x3 mm Body [UQFN]

Note: For the most current package drawings, please see the Microchip Packaging Specification located at <http://www.microchip.com/packaging>

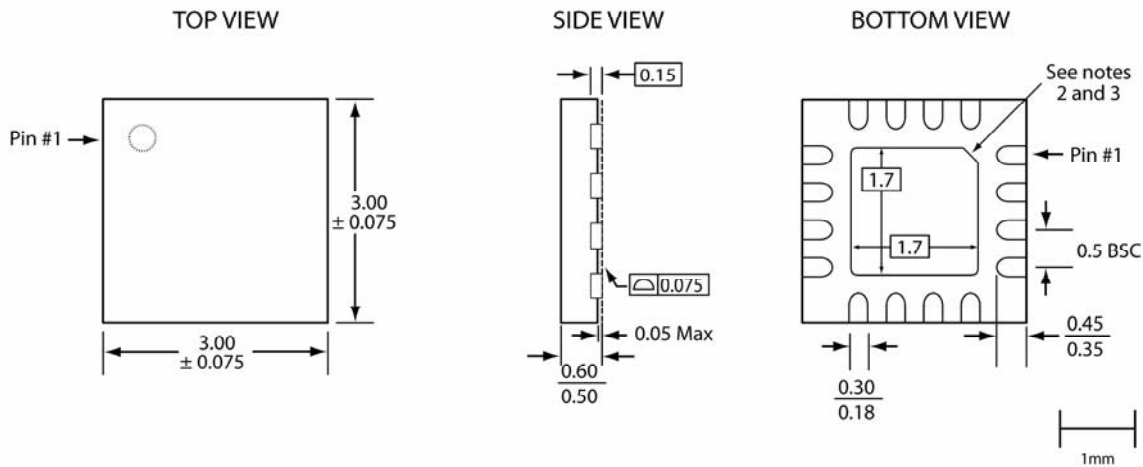

16-uqfn-3x3-QUC-0.0

Note:

1. Complies with JEDEC JEP95 MO-248D, variant UEED-4 except external paddle nominal dimensions.
2. From the bottom view, the pin #1 indicator may be either a 45-degree chamfer or a half-circle notch.
3. The external paddle is electrically connected to the die back-side and possibly to certain VSS leads. This paddle can be soldered to the PC board; it is suggested to connect this paddle to the VSS of the unit. Connection of this paddle to any other voltage potential can result in shorts and/or electrical malfunction of the device.
4. Untoleranced dimensions are nominal target dimensions.
5. All linear dimensions are in millimeters (max/min).

TABLE 7-1: REVISION HISTORY

Revision	Description	Date
A	<ul style="list-style-type: none">Initial release of data sheet	Aug 2014

THE MICROCHIP WEB SITE

Microchip provides online support via our WWW site at www.microchip.com. This web site is used as a means to make files and information easily available to customers. Accessible by using your favorite Internet browser, the web site contains the following information:

- **Product Support** – Data sheets and errata, application notes and sample programs, design resources, user's guides and hardware support documents, latest software releases and archived software
- **General Technical Support** – Frequently Asked Questions (FAQ), technical support requests, online discussion groups, Microchip consultant program member listing
- **Business of Microchip** – Product selector and ordering guides, latest Microchip press releases, listing of seminars and events, listings of Microchip sales offices, distributors and factory representatives

CUSTOMER CHANGE NOTIFICATION SERVICE

Microchip's customer notification service helps keep customers current on Microchip products. Subscribers will receive e-mail notification whenever there are changes, updates, revisions or errata related to a specified product family or development tool of interest.

To register, access the Microchip web site at www.microchip.com. Under "Support", click on "Customer Change Notification" and follow the registration instructions.

CUSTOMER SUPPORT

Users of Microchip products can receive assistance through several channels:

- Distributor or Representative
- Local Sales Office
- Field Application Engineer (FAE)
- Technical Support

Customers should contact their distributor, representative or Field Application Engineer (FAE) for support. Local sales offices are also available to help customers. A listing of sales offices and locations is included in the back of this document.

Technical support is available through the web site at: <http://microchip.com/support>

8.0 PRODUCT IDENTIFICATION SYSTEM

To order or obtain information, e.g., on pricing or delivery, refer to the factory or the listed sales office.

<u>PART NO.</u>		<u>XXX</u>
Device		Package
Device:	SST12CP21	= 2.4 GHz High-Gain, High-Efficiency Power Amplifier
Package:	QUCE	= UQFN (3mm x 3mm), 0.6 max thickness 16-contact
Evaluation Kit Flag	K	= Evaluation Kit

Valid Combinations:
 SST12CP21-QUCE
 SST12CP21-QUCE-K

Note the following details of the code protection feature on Microchip devices:

- Microchip products meet the specification contained in their particular Microchip Data Sheet.
- Microchip believes that its family of products is one of the most secure families of its kind on the market today, when used in the intended manner and under normal conditions.
- There are dishonest and possibly illegal methods used to breach the code protection feature. All of these methods, to our knowledge, require using the Microchip products in a manner outside the operating specifications contained in Microchip's Data Sheets. Most likely, the person doing so is engaged in theft of intellectual property.
- Microchip is willing to work with the customer who is concerned about the integrity of their code.
- Neither Microchip nor any other semiconductor manufacturer can guarantee the security of their code. Code protection does not mean that we are guaranteeing the product as "unbreakable."

Code protection is constantly evolving. We at Microchip are committed to continuously improving the code protection features of our products. Attempts to break Microchip's code protection feature may be a violation of the Digital Millennium Copyright Act. If such acts allow unauthorized access to your software or other copyrighted work, you may have a right to sue for relief under that Act.

Information contained in this publication regarding device applications and the like is provided only for your convenience and may be superseded by updates. It is your responsibility to ensure that your application meets with your specifications. MICROCHIP MAKES NO REPRESENTATIONS OR WARRANTIES OF ANY KIND WHETHER EXPRESS OR IMPLIED, WRITTEN OR ORAL, STATUTORY OR OTHERWISE, RELATED TO THE INFORMATION, INCLUDING BUT NOT LIMITED TO ITS CONDITION, QUALITY, PERFORMANCE, MERCHANTABILITY OR FITNESS FOR PURPOSE. Microchip disclaims all liability arising from this information and its use. Use of Microchip devices in life support and/or safety applications is entirely at the buyer's risk, and the buyer agrees to defend, indemnify and hold harmless Microchip from any and all damages, claims, suits, or expenses resulting from such use. No licenses are conveyed, implicitly or otherwise, under any Microchip intellectual property rights.

Trademarks

The Microchip name and logo, the Microchip logo, dsPIC, FlashFlex, flexPWR, JukeBlox, KEELOQ, KEELOQ logo, Kleer, LANCheck, MediaLB, MOST, MOST logo, MPLAB, OptoLyzer, PIC, PICSTART, PIC³² logo, RightTouch, SpyNIC, SST, SST Logo, SuperFlash and UNI/O are registered trademarks of Microchip Technology Incorporated in the U.S.A. and other countries.

The Embedded Control Solutions Company and mTouch are registered trademarks of Microchip Technology Incorporated in the U.S.A.

Analog-for-the-Digital Age, BodyCom, chipKIT, chipKIT logo, CodeGuard, dsPICDEM, dsPICDEM.net, ECAN, In-Circuit Serial Programming, ICSP, Inter-Chip Connectivity, KleerNet, KleerNet logo, MiWi, MPASM, MPF, MPLAB Certified logo, MPLIB, MPLINK, MultiTRAK, NetDetach, Omniscient Code Generation, PICDEM, PICDEM.net, PICKit, PICtail, RightTouch logo, REAL ICE, SQI, Serial Quad I/O, Total Endurance, TSHARC, USBCheck, VariSense, ViewSpan, WiperLock, Wireless DNA, and ZENA are trademarks of Microchip Technology Incorporated in the U.S.A. and other countries.

SQTP is a service mark of Microchip Technology Incorporated in the U.S.A.

Silicon Storage Technology is a registered trademark of Microchip Technology Inc. in other countries.

GestIC is a registered trademarks of Microchip Technology Germany II GmbH & Co. KG, a subsidiary of Microchip Technology Inc., in other countries.

All other trademarks mentioned herein are property of their respective companies.

© 2014, Microchip Technology Incorporated, Printed in the U.S.A., All Rights Reserved.

ISBN:
978-1-63276-526-0

Microchip received ISO/TS-16949:2009 certification for its worldwide headquarters, design and wafer fabrication facilities in Chandler and Tempe, Arizona; Gresham, Oregon and design centers in California and India. The Company's quality system processes and procedures are for its PIC® MCUs and dsPIC® DSCs, KEELOQ® code hopping devices, Serial EEPROMs, microperipherals, nonvolatile memory and analog products. In addition, Microchip's quality system for the design and manufacture of development systems is ISO 9001:2000 certified.

**QUALITY MANAGEMENT SYSTEM
CERTIFIED BY DNV
= ISO/TS 16949 =**



World Wide Sales and Service

AMERICAS

Corporate Office
2355 West Chandler Blvd.
Chandler, AZ 85224-6199
Tel: 480-792-7200
Fax: 480-792-7277
Technical Support:
[http://www.microchip.com/
support](http://www.microchip.com/support)
Web Address:
www.microchip.com

Atlanta

Duluth, GA
Tel: 678-957-9614
Fax: 678-957-1455

Austin, TX

Tel: 512-257-3370

Boston

Westborough, MA
Tel: 774-760-0087
Fax: 774-760-0088

Chicago

Itasca, IL
Tel: 630-285-0071
Fax: 630-285-0075

Cleveland

Independence, OH
Tel: 216-447-0464
Fax: 216-447-0643

Dallas

Addison, TX
Tel: 972-818-7423
Fax: 972-818-2924

Detroit

Novi, MI
Tel: 248-848-4000

Houston, TX

Tel: 281-894-5983

Indianapolis

Noblesville, IN
Tel: 317-773-8323
Fax: 317-773-5453

Los Angeles

Mission Viejo, CA
Tel: 949-462-9523
Fax: 949-462-9608

New York, NY

Tel: 631-435-6000

San Jose, CA

Tel: 408-735-9110

Canada - Toronto

Tel: 905-673-0699
Fax: 905-673-6509

ASIA/PACIFIC

Asia Pacific Office
Suites 3707-14, 37th Floor
Tower 6, The Gateway
Harbour City, Kowloon
Hong Kong
Tel: 852-2943-5100
Fax: 852-2401-3431

Australia - Sydney

Tel: 61-2-9868-6733
Fax: 61-2-9868-6755

China - Beijing

Tel: 86-10-8569-7000
Fax: 86-10-8528-2104

China - Chengdu

Tel: 86-28-8665-5511
Fax: 86-28-8665-7889

China - Chongqing

Tel: 86-23-8980-9588
Fax: 86-23-8980-9500

China - Hangzhou

Tel: 86-571-8792-8115
Fax: 86-571-8792-8116

China - Hong Kong SAR

Tel: 852-2943-5100
Fax: 852-2401-3431

China - Nanjing

Tel: 86-25-8473-2460
Fax: 86-25-8473-2470

China - Qingdao

Tel: 86-532-8502-7355
Fax: 86-532-8502-7205

China - Shanghai

Tel: 86-21-5407-5533
Fax: 86-21-5407-5066

China - Shenyang

Tel: 86-24-2334-2829
Fax: 86-24-2334-2393

China - Shenzhen

Tel: 86-755-8864-2200
Fax: 86-755-8203-1760

China - Wuhan

Tel: 86-27-5980-5300
Fax: 86-27-5980-5118

China - Xian

Tel: 86-29-8833-7252
Fax: 86-29-8833-7256

China - Xiamen

Tel: 86-592-2388138
Fax: 86-592-2388130

China - Zhuhai

Tel: 86-756-3210040
Fax: 86-756-3210049

ASIA/PACIFIC

India - Bangalore
Tel: 91-80-3090-4444
Fax: 91-80-3090-4123

India - New Delhi

Tel: 91-11-4160-8631
Fax: 91-11-4160-8632

India - Pune

Tel: 91-20-3019-1500

Japan - Osaka

Tel: 81-6-6152-7160
Fax: 81-6-6152-9310

Japan - Tokyo

Tel: 81-3-6880-3770
Fax: 81-3-6880-3771

Korea - Daegu

Tel: 82-53-744-4301
Fax: 82-53-744-4302

Korea - Seoul

Tel: 82-2-554-7200
Fax: 82-2-558-5932 or
82-2-558-5934

Malaysia - Kuala Lumpur

Tel: 60-3-6201-9857
Fax: 60-3-6201-9859

Malaysia - Penang

Tel: 60-4-227-8870
Fax: 60-4-227-4068

Philippines - Manila

Tel: 63-2-634-9065
Fax: 63-2-634-9069

Singapore

Tel: 65-6334-8870
Fax: 65-6334-8850

Taiwan - Hsin Chu

Tel: 886-3-5778-366
Fax: 886-3-5770-955

Taiwan - Kaohsiung

Tel: 886-7-213-7830

Taiwan - Taipei

Tel: 886-2-2508-8600
Fax: 886-2-2508-0102

Thailand - Bangkok

Tel: 66-2-694-1351
Fax: 66-2-694-1350

EUROPE

Austria - Wels

Tel: 43-7242-2244-39
Fax: 43-7242-2244-393

Denmark - Copenhagen

Tel: 45-4450-2828
Fax: 45-4485-2829

France - Paris

Tel: 33-1-69-53-63-20
Fax: 33-1-69-30-90-79

Germany - Dusseldorf

Tel: 49-2129-3766400

Germany - Munich

Tel: 49-89-627-144-0
Fax: 49-89-627-144-44

Germany - Pforzheim

Tel: 49-7231-424750

Italy - Milan

Tel: 39-0331-742611
Fax: 39-0331-466781

Italy - Venice

Tel: 39-049-7625286

Netherlands - Druenen

Tel: 31-416-690399
Fax: 31-416-690340

Poland - Warsaw

Tel: 48-22-3325737

Spain - Madrid

Tel: 34-91-708-08-90
Fax: 34-91-708-08-91

Sweden - Stockholm

Tel: 46-8-5090-4654

UK - Wokingham

Tel: 44-118-921-5800
Fax: 44-118-921-5820