

REVISIONS					
P	LTR	DESCRIPTION	DATE	DWN	APVD
A1		ECR-19-014657	13DEC2020	RR	SZ

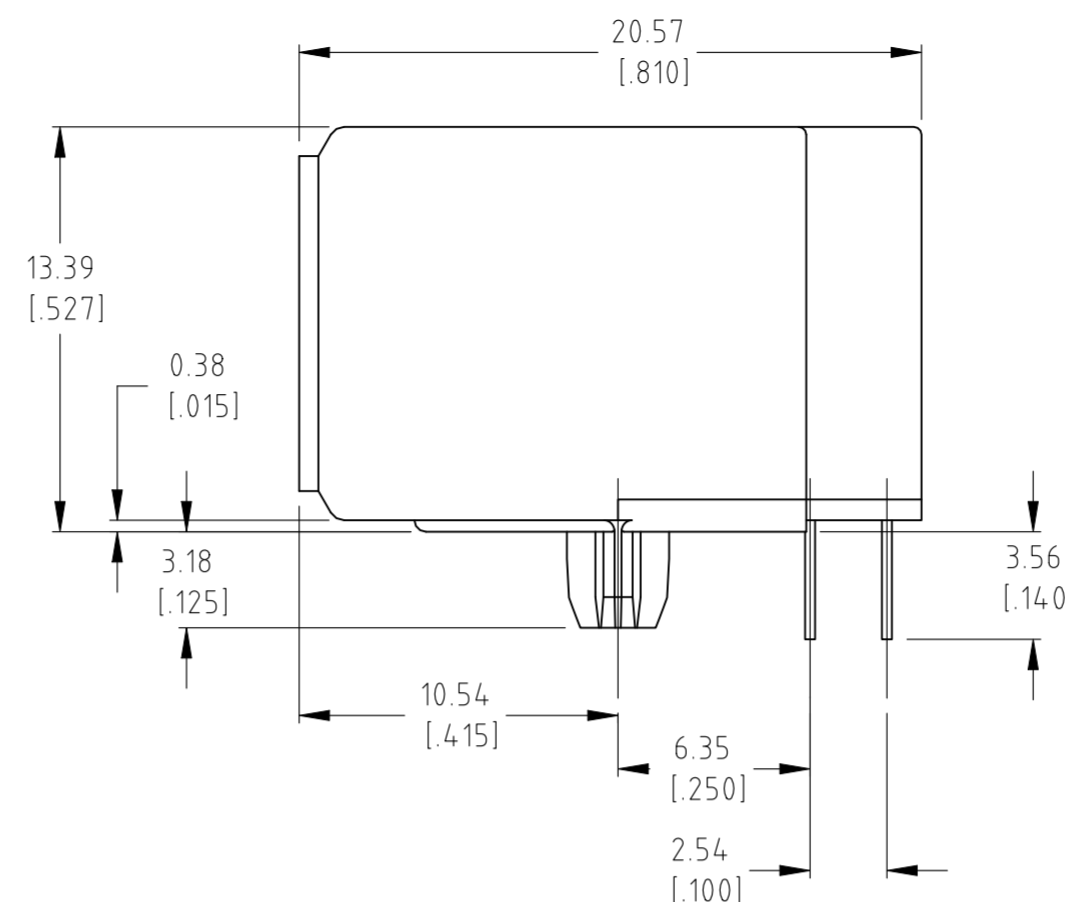
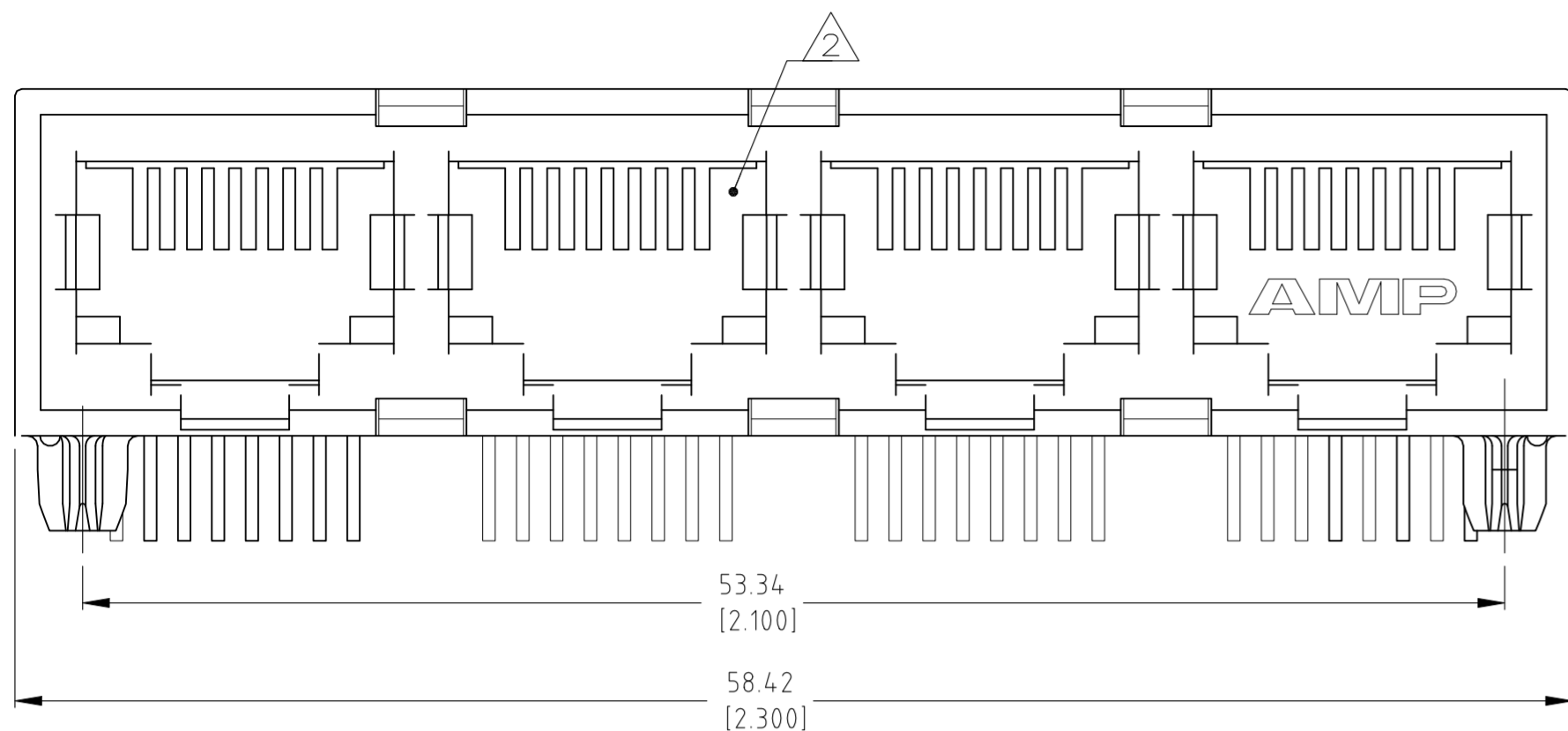

1. MATERIAL: HOUSING – HIGH TEMPERATURE NYLON, BLACK, IR COMPATIBLE, UL 94V-0.
 TERMINALS – 0.33[.013] THICK PHOS BRONZE PLATED WITH 1.27 μ m[.000050] MINIMUM HARD GOLD ON LOCALIZED AREA AND 3.81 μ m [.000150] MINIMUM MATTE TIN IN SOLDER AREA OVER 1.27 μ m [.000050] MINIMUM NICKEL UNDERPLATE.

2. JACK CAVITY CONFORMS TO FCC RULES AND REGULATIONS, PART 68 SUBPART F.

3. CAUTION: CATEGORY 5 JACK SOLDER TAIL POSITIONS DO NOT FOLLOW SAME NUMBER SEQUENCE AS THAT OF THE TRADITIONAL JACKS.



TRADITIONAL JACK 3 CATEGORY 5 & 5e JACK

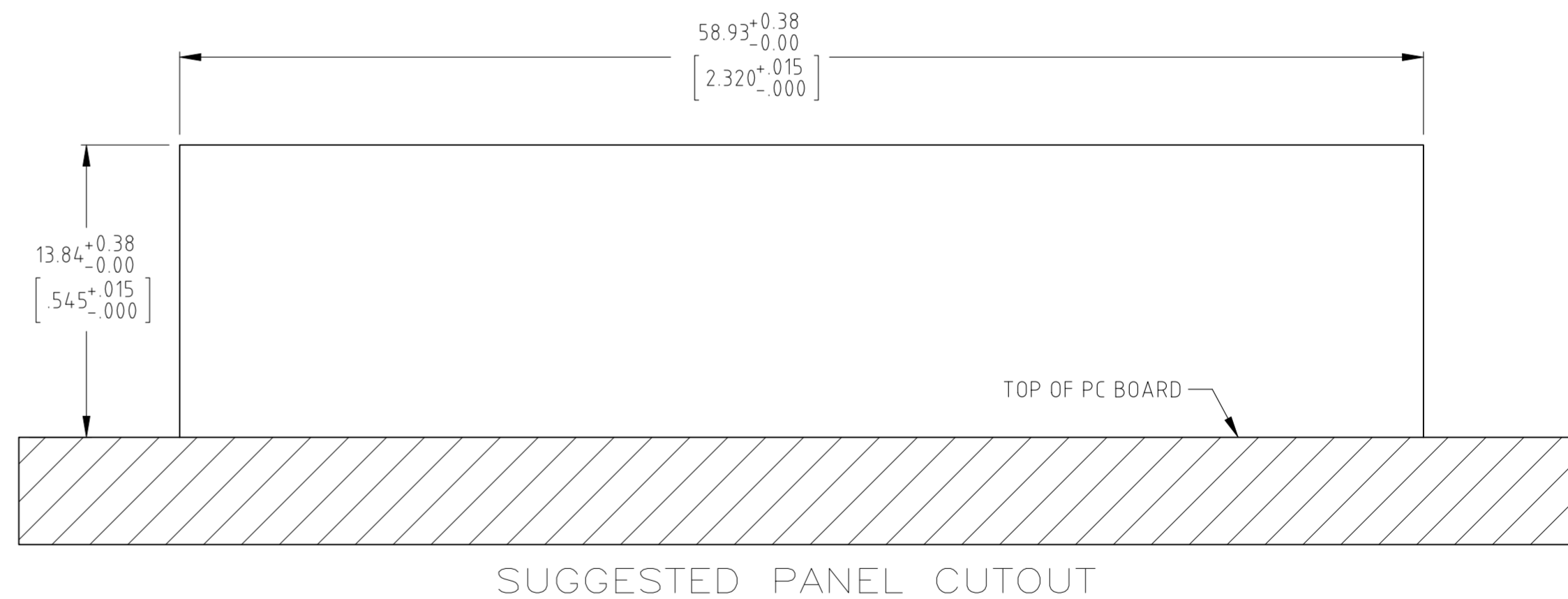
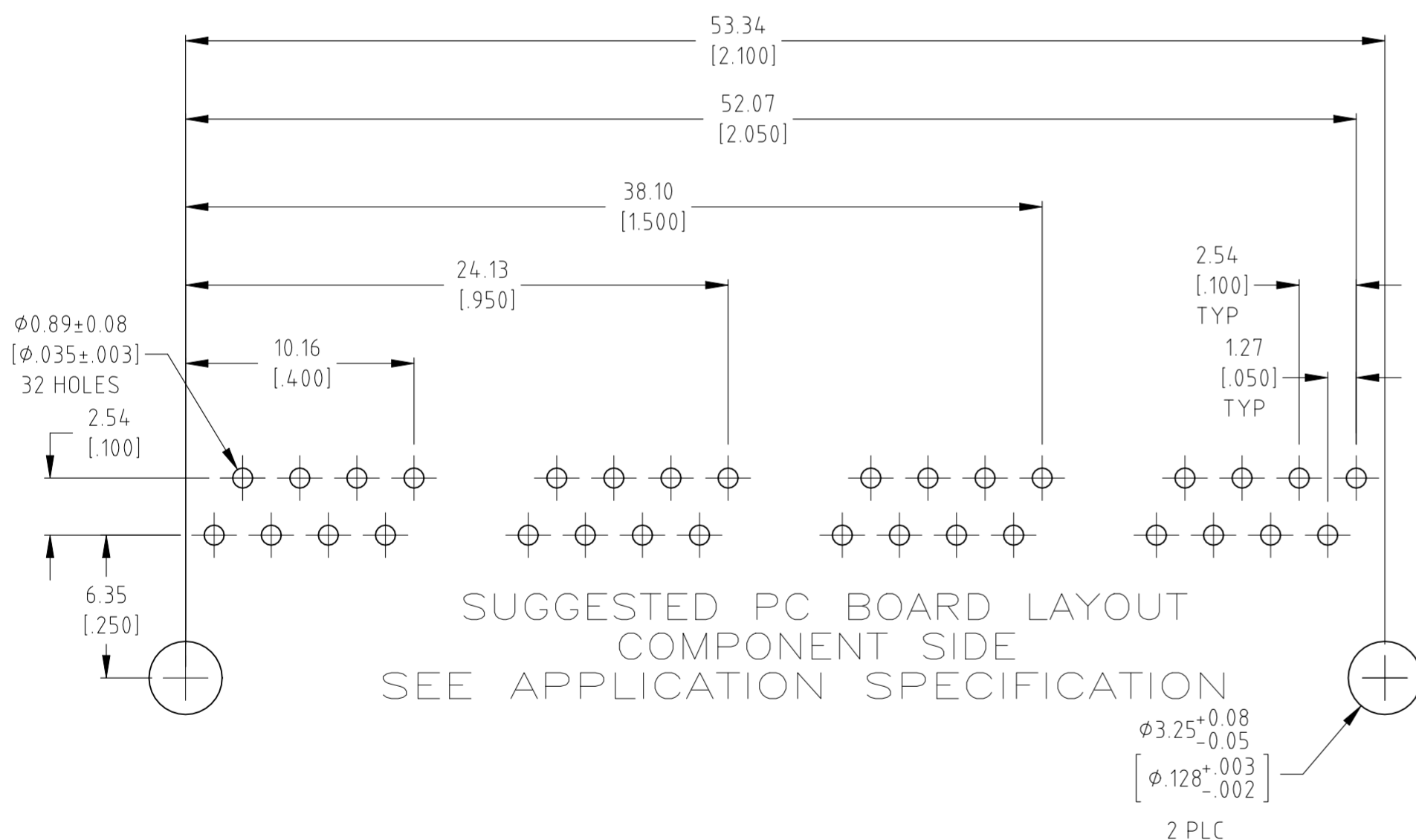

1932371-1
 PART NO.

THIS DRAWING IS A CONTROLLED DOCUMENT.		DWN TERRY.YU 19MAY2009	TE Connectivity		
DIMENSIONS: mm [INCHES]		CHK MARTIN.LI 19MAY2009			
TOLERANCES UNLESS OTHERWISE SPECIFIED:		APVD STEVEN.YAO 19MAY2009	NAME		
0 PLC ± -		PRODUCT SPEC	MODULAR JACK ASSEMBLY, 4 PORT, 8 POSITION, RIGHT ANGLE, CATEGORY 5e		
1 PLC ± -		APPLICATION SPEC	SIZE	CAGE CODE	DRAWING NO
2 PLC ± 0.25 [.010]		108-1392	A2	00779	C=1932371
3 PLC ± -		114-2048	RESTRICTED TO		
4 PLC ± -		WEIGHT	-		
ANGLES ± -		0.000000	SCALE 4:1 SHEET 1 OF 1 REV A1		
FINISH		CUSTOMER DRAWING			
SEE NOTE 1					