



## N-CHANNEL MOSFET

Qualified per MIL-PRF-19500/557

Qualified Levels:  
JAN, JANTX, JANTXV  
and JANS\*

### DESCRIPTION

This family of switching transistors is military qualified up to the JANTXV level for high-reliability applications. The 2N6798U part number is also qualified to the JANS level. These devices are also available in a TO-205AF (TO-39) package. Microsemi also offers numerous other transistor products to meet higher and lower power ratings with various switching speed requirements in both through-hole and surface-mount packages.

**Important:** For the latest information, visit our website <http://www.microsemi.com>.

### FEATURES

- Surface mount equivalent of JEDEC registered 2N6796, 2N6798, 2N6800 and 2N6802 number series.
- JAN, JANTX, and JANTXV qualifications are available per MIL-PRF-19500/557.  
\*JANS qualification is available on 2N6798U only.  
(See [part nomenclature](#) for all available options.)
- RoHS compliant by design.

### APPLICATIONS / BENEFITS

- Compact surface mount design enables mounting in crowded areas.
- Military and other high-reliability applications.

### MAXIMUM RATINGS @ T<sub>A</sub> = +25 °C unless otherwise stated

Parameters / Test Conditions	Symbol	Value	Unit
Operating & Storage Junction Temperature Range	T <sub>J</sub> & T <sub>stg</sub>	-55 to +150	°C
Thermal Resistance Junction-to-Case (see <a href="#">Figure 1</a> )	R <sub>θJC</sub>	5.0	°C/W
Total Power Dissipation	P <sub>T</sub>	@ T <sub>A</sub> = +25 °C	0.8
		@ T <sub>C</sub> = +25 °C <sup>(1)</sup>	25
Drain-Source Voltage, dc	V <sub>DS</sub>	2N6796U	100
		2N6798U	200
		2N6800U	400
		2N6802U	500
Gate-Source Voltage, dc	V <sub>GS</sub>	± 20	V
Drain Current, dc @ T <sub>C</sub> = +25 °C <sup>(2)</sup>	I <sub>D1</sub>	2N6796U	8.0
		2N6798U	5.5
		2N6800U	3.0
		2N6802U	2.5
Drain Current, dc @ T <sub>C</sub> = +100 °C <sup>(2)</sup>	I <sub>D2</sub>	2N6796U	5.0
		2N6798U	3.5
		2N6800U	2.0
		2N6802U	1.5
Off-State Current (Peak Total Value) <sup>(3)</sup>	I <sub>DM</sub>	2N6796U	32
		2N6798U	22
		2N6800U	14
		2N6802U	11
Source Current	I <sub>S</sub>	2N6796U	8.0
		2N6798U	5.5
		2N6800U	3.0
		2N6802U	2.5

See notes on next page.

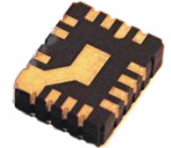

### U-18 LCC Package

Also available in:

**TO-205AF (TO-39) package**

(Leaded Top Hat)  
2N6796, 2N6798,  
2N6800 & 2N6802

#### MSC – Lawrence

6 Lake Street, Lawrence,  
MA 01841  
Tel: 1-800-446-1158 or  
(978) 620-2600  
Fax: (978) 689-0803

#### MSC – Ireland

Gort Road Business Park,  
Ennis, Co. Clare, Ireland  
Tel: +353 (0) 65 6840044  
Fax: +353 (0) 65 6822298

Website:

[www.microsemi.com](http://www.microsemi.com)

- Notes:**
- Derate linearly 0.2 W/°C for  $T_C > +25\text{ }^\circ\text{C}$ .
  - The following formula derives the maximum theoretical  $I_D$  limit.  $I_D$  is also limited by package and internal wires and may be limited due to pin diameter.

$$I_D = \sqrt{\frac{T_J(\text{max}) - T_C}{R_{\theta JC} \times R_{DS(on)} @ T_J(\text{max})}}$$

- $I_{DM} = 4 \times I_{D1}$  as calculated in note 1.

### MECHANICAL and PACKAGING

- CASE: Ceramic LCC-18 with kovar gold plated lid.
- TERMINALS: Gold plating over nickel.
- MARKING: Manufacturer's ID, part number, date code, ESD symbol at Pin 1 location.
- TAPE & REEL option: Standard per EIA-481-D. Consult factory for quantities.
- See [Package Dimensions](#) on last page.

### PART NOMENCLATURE

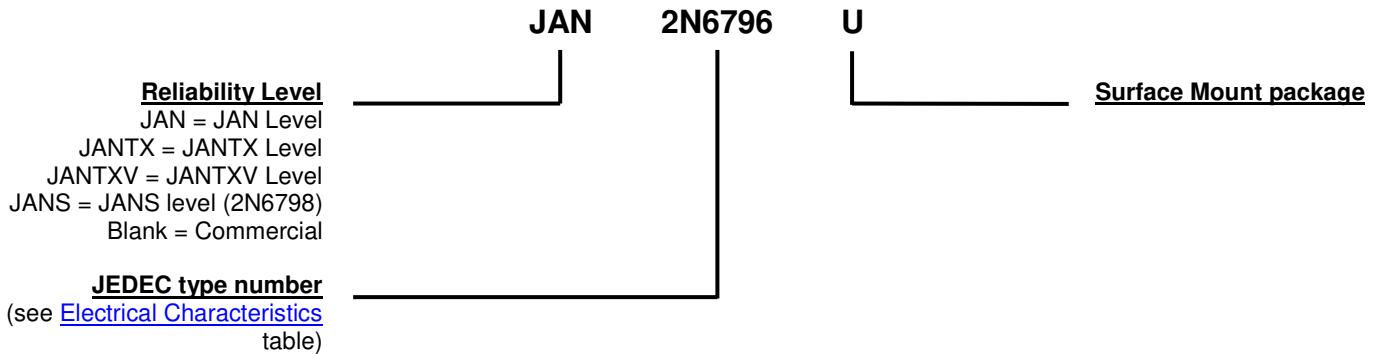

### SYMBOLS & DEFINITIONS

Symbol	Definition
di/dt	Rate of change of diode current while in reverse-recovery mode, recorded as maximum value.
$I_F$	Forward current
$R_G$	Gate drive impedance
$V_{DD}$	Drain supply voltage
$V_{DS}$	Drain source voltage, dc
$V_{GS}$	Gate source voltage, dc

**ELECTRICAL CHARACTERISTICS @  $T_A = +25\text{ }^\circ\text{C}$ , unless otherwise noted**

Parameters / Test Conditions	Symbol	Min.	Max.	Unit
<b>OFF CHARACTERISTICS</b>				
Drain-Source Breakdown Voltage $V_{GS} = 0\text{ V}, I_D = 1.0\text{ mA}$	$V_{(BR)DSS}$	100 200 400 500		V
Gate-Source Voltage (Threshold) $V_{DS} \geq V_{GS}, I_D = 0.25\text{ mA}$ $V_{DS} \geq V_{GS}, I_D = 0.25\text{ mA}, T_J = +125\text{ }^\circ\text{C}$ $V_{DS} \geq V_{GS}, I_D = 0.25\text{ mA}, T_J = -55\text{ }^\circ\text{C}$	$V_{GS(th)1}$ $V_{GS(th)2}$ $V_{GS(th)3}$	2.0 1.0	4.0 5.0	V
Gate Current $V_{GS} = \pm 20\text{ V}, V_{DS} = 0\text{ V}$ $V_{GS} = \pm 20\text{ V}, V_{DS} = 0\text{ V}, T_J = +125\text{ }^\circ\text{C}$	$I_{GSS1}$ $I_{GSS2}$		$\pm 100$ $\pm 200$	nA
Drain Current $V_{GS} = 0\text{ V}, V_{DS} = 80\text{ V}$ $V_{GS} = 0\text{ V}, V_{DS} = 160\text{ V}$ $V_{GS} = 0\text{ V}, V_{DS} = 320\text{ V}$ $V_{GS} = 0\text{ V}, V_{DS} = 400\text{ V}$	$I_{DSS1}$		25	$\mu\text{A}$
Drain Current $V_{GS} = 0\text{ V}, V_{DS} = 80\text{ V}, T_J = +125\text{ }^\circ\text{C}$ $V_{GS} = 0\text{ V}, V_{DS} = 160\text{ V}, T_J = +125\text{ }^\circ\text{C}$ $V_{GS} = 0\text{ V}, V_{DS} = 320\text{ V}, T_J = +125\text{ }^\circ\text{C}$ $V_{GS} = 0\text{ V}, V_{DS} = 400\text{ V}, T_J = +125\text{ }^\circ\text{C}$	$I_{DSS2}$		0.25	mA
Static Drain-Source On-State Resistance $V_{GS} = 10\text{ V}, I_D = 5.0\text{ A pulsed}$ $V_{GS} = 10\text{ V}, I_D = 3.5\text{ A pulsed}$ $V_{GS} = 10\text{ V}, I_D = 2.0\text{ A pulsed}$ $V_{GS} = 10\text{ V}, I_D = 1.5\text{ A pulsed}$	$r_{DS(on)1}$		0.18 0.40 1.00 1.50	$\Omega$
Static Drain-Source On-State Resistance $V_{GS} = 10\text{ V}, I_D = 8.0\text{ A pulsed}$ $V_{GS} = 10\text{ V}, I_D = 5.5\text{ A pulsed}$ $V_{GS} = 10\text{ V}, I_D = 3.0\text{ A pulsed}$ $V_{GS} = 10\text{ V}, I_D = 2.5\text{ A pulsed}$	$r_{DS(on)2}$		0.195 0.420 1.100 1.600	$\Omega$
Static Drain-Source On-State Resistance $T_J = +125\text{ }^\circ\text{C}$ $V_{GS} = 10\text{ V}, I_D = 5.0\text{ A pulsed}$ $V_{GS} = 10\text{ V}, I_D = 3.5\text{ A pulsed}$ $V_{GS} = 10\text{ V}, I_D = 2.0\text{ A pulsed}$ $V_{GS} = 10\text{ V}, I_D = 1.5\text{ A pulsed}$	$r_{DS(on)3}$		0.35 0.75 2.40 3.50	$\Omega$
Diode Forward Voltage $V_{GS} = 0\text{ V}, I_D = 8.0\text{ A pulsed}$ $V_{GS} = 0\text{ V}, I_D = 5.5\text{ A pulsed}$ $V_{GS} = 0\text{ V}, I_D = 3.0\text{ A pulsed}$ $V_{GS} = 0\text{ V}, I_D = 2.5\text{ A pulsed}$	$V_{SD}$		1.5 1.4 1.4 1.4	V

**ELECTRICAL CHARACTERISTICS @  $T_A = +25\text{ }^\circ\text{C}$ , unless otherwise noted (continued)**
**DYNAMIC CHARACTERISTICS**

Parameters / Test Conditions	Symbol	Min.	Max.	Unit
<b>Gate Charge:</b>				
On-State Gate Charge				
$V_{GS} = 10\text{ V}, I_D = 8.0\text{ A}, V_{DS} = 50\text{ V}$ 2N6796U	$Q_{g(\text{on})}$		28.51	nC
$V_{GS} = 10\text{ V}, I_D = 5.5\text{ A}, V_{DS} = 50\text{ V}$ 2N6798U		42.07		
$V_{GS} = 10\text{ V}, I_D = 3.0\text{ A}, V_{DS} = 50\text{ V}$ 2N6800U		34.75		
$V_{GS} = 10\text{ V}, I_D = 2.5\text{ A}, V_{DS} = 50\text{ V}$ 2N6802U		33.00		
Gate to Source Charge				
$V_{GS} = 10\text{ V}, I_D = 8.0\text{ A}, V_{DS} = 50\text{ V}$ 2N6796U	$Q_{gs}$		6.34	nC
$V_{GS} = 10\text{ V}, I_D = 5.5\text{ A}, V_{DS} = 50\text{ V}$ 2N6798U		5.29		
$V_{GS} = 10\text{ V}, I_D = 3.0\text{ A}, V_{DS} = 50\text{ V}$ 2N6800U		5.75		
$V_{GS} = 10\text{ V}, I_D = 2.5\text{ A}, V_{DS} = 50\text{ V}$ 2N6802U		4.46		
Gate to Drain Charge				
$V_{GS} = 10\text{ V}, I_D = 8.0\text{ A}, V_{DS} = 50\text{ V}$ 2N6796U	$Q_{gd}$		16.59	nC
$V_{GS} = 10\text{ V}, I_D = 5.5\text{ A}, V_{DS} = 50\text{ V}$ 2N6798U		28.11		
$V_{GS} = 10\text{ V}, I_D = 3.0\text{ A}, V_{DS} = 50\text{ V}$ 2N6800U		16.59		
$V_{GS} = 10\text{ V}, I_D = 2.5\text{ A}, V_{DS} = 50\text{ V}$ 2N6802U		28.11		

**SWITCHING CHARACTERISTICS**

Parameters / Test Conditions	Symbol	Min.	Max.	Unit
Turn-on delay time				
$I_D = 8.0\text{ A}, V_{GS} = +10\text{ V}, R_G = 7.5\text{ }\Omega, V_{DD} = 30\text{ V}$ 2N6796U	$t_{d(\text{on})}$		30	ns
$I_D = 5.5\text{ A}, V_{GS} = +10\text{ V}, R_G = 7.5\text{ }\Omega, V_{DD} = 77\text{ V}$ 2N6798U				
$I_D = 3.0\text{ A}, V_{GS} = +10\text{ V}, R_G = 7.5\text{ }\Omega, V_{DD} = 176\text{ V}$ 2N6800U				
$I_D = 2.5\text{ A}, V_{GS} = +10\text{ V}, R_G = 7.5\text{ }\Omega, V_{DD} = 225\text{ V}$ 2N6802U				
Rinse time				
$I_D = 8.0\text{ A}, V_{GS} = +10\text{ V}, R_G = 7.5\text{ }\Omega, V_{DD} = 30\text{ V}$ 2N6796U	$t_r$		75	ns
$I_D = 5.5\text{ A}, V_{GS} = +10\text{ V}, R_G = 7.5\text{ }\Omega, V_{DD} = 77\text{ V}$ 2N6798U		50		
$I_D = 3.0\text{ A}, V_{GS} = +10\text{ V}, R_G = 7.5\text{ }\Omega, V_{DD} = 176\text{ V}$ 2N6800U		35		
$I_D = 2.5\text{ A}, V_{GS} = +10\text{ V}, R_G = 7.5\text{ }\Omega, V_{DD} = 225\text{ V}$ 2N6802U		30		
Turn-off delay time				
$I_D = 8.0\text{ A}, V_{GS} = +10\text{ V}, R_G = 7.5\text{ }\Omega, V_{DD} = 30\text{ V}$ 2N6796U	$t_{d(\text{off})}$		40	ns
$I_D = 5.5\text{ A}, V_{GS} = +10\text{ V}, R_G = 7.5\text{ }\Omega, V_{DD} = 77\text{ V}$ 2N6798U		50		
$I_D = 3.0\text{ A}, V_{GS} = +10\text{ V}, R_G = 7.5\text{ }\Omega, V_{DD} = 176\text{ V}$ 2N6800U		55		
$I_D = 2.5\text{ A}, V_{GS} = +10\text{ V}, R_G = 7.5\text{ }\Omega, V_{DD} = 225\text{ V}$ 2N6802U		55		
Fall time				
$I_D = 8.0\text{ A}, V_{GS} = +10\text{ V}, R_G = 7.5\text{ }\Omega, V_{DD} = 30\text{ V}$ 2N6796U	$t_f$		45	ns
$I_D = 5.5\text{ A}, V_{GS} = +10\text{ V}, R_G = 7.5\text{ }\Omega, V_{DD} = 77\text{ V}$ 2N6798U		40		
$I_D = 3.0\text{ A}, V_{GS} = +10\text{ V}, R_G = 7.5\text{ }\Omega, V_{DD} = 176\text{ V}$ 2N6800U		35		
$I_D = 2.5\text{ A}, V_{GS} = +10\text{ V}, R_G = 7.5\text{ }\Omega, V_{DD} = 225\text{ V}$ 2N6802U		30		
Diode Reverse Recovery Time				
$di/dt \leq 100\text{ A}/\mu\text{s}, V_{DD} \leq 50\text{ V}, I_F = 8.0\text{ A}$ 2N6796U	$t_{rr}$		300	ns
$di/dt \leq 100\text{ A}/\mu\text{s}, V_{DD} \leq 50\text{ V}, I_F = 5.5\text{ A}$ 2N6798U		500		
$di/dt \leq 100\text{ A}/\mu\text{s}, V_{DD} \leq 50\text{ V}, I_F = 3.0\text{ A}$ 2N6800U		700		
$di/dt \leq 100\text{ A}/\mu\text{s}, V_{DD} \leq 50\text{ V}, I_F = 2.5\text{ A}$ 2N6802U		900		

## GRAPHS

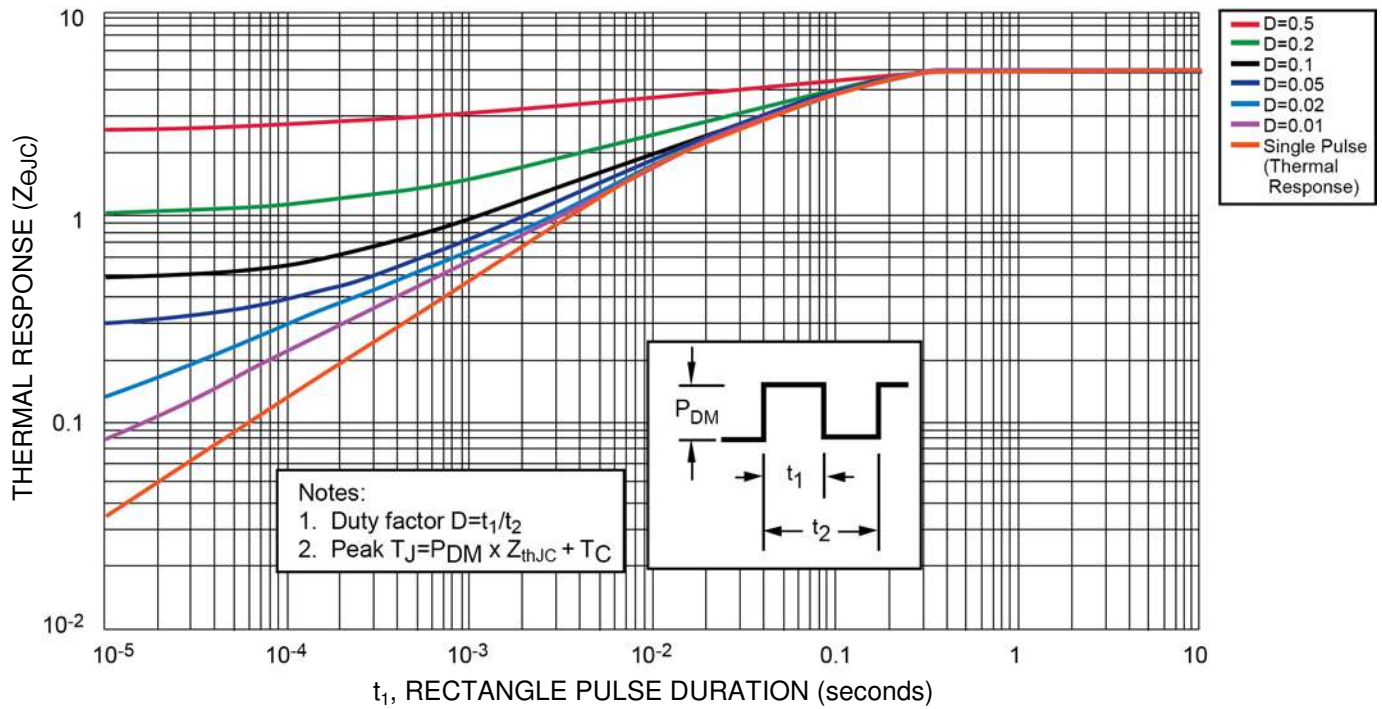
**FIGURE 1 – Normalized Transient Thermal Impedance**

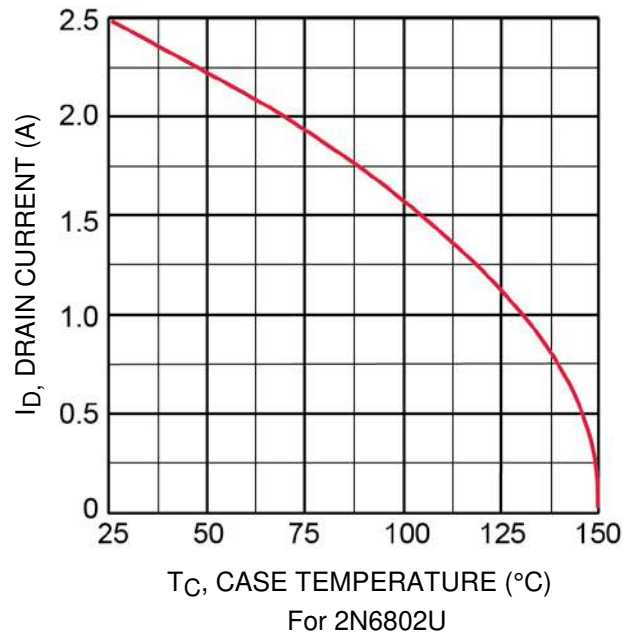
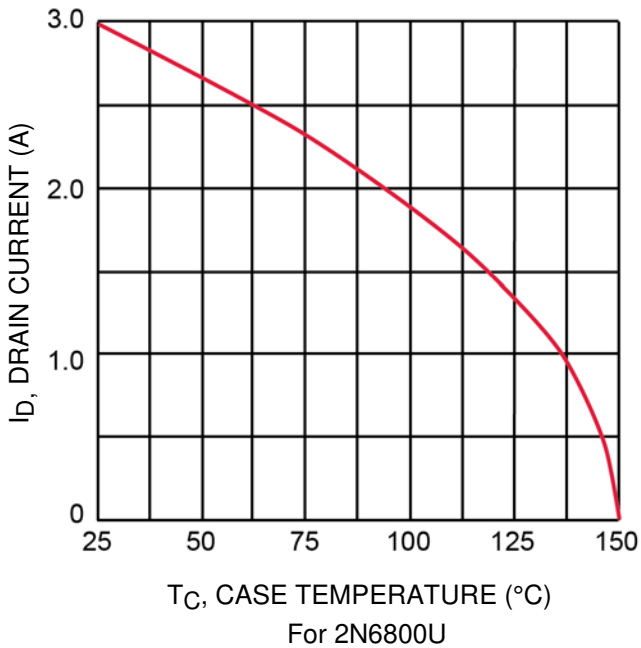
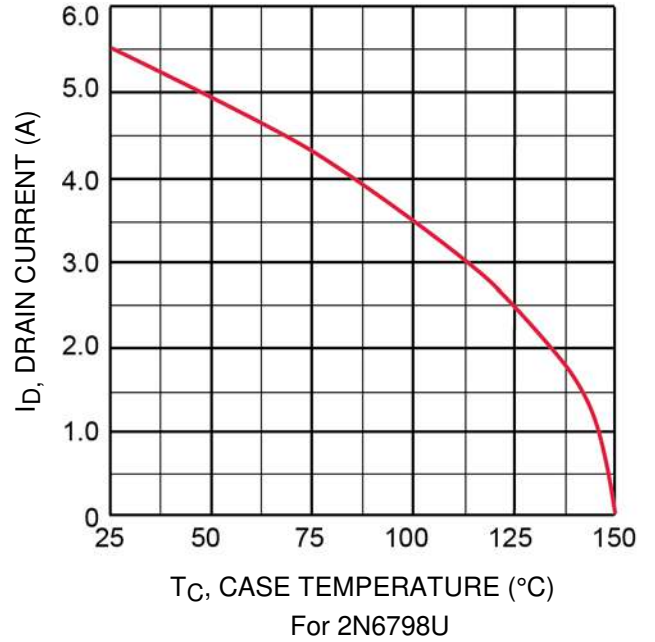
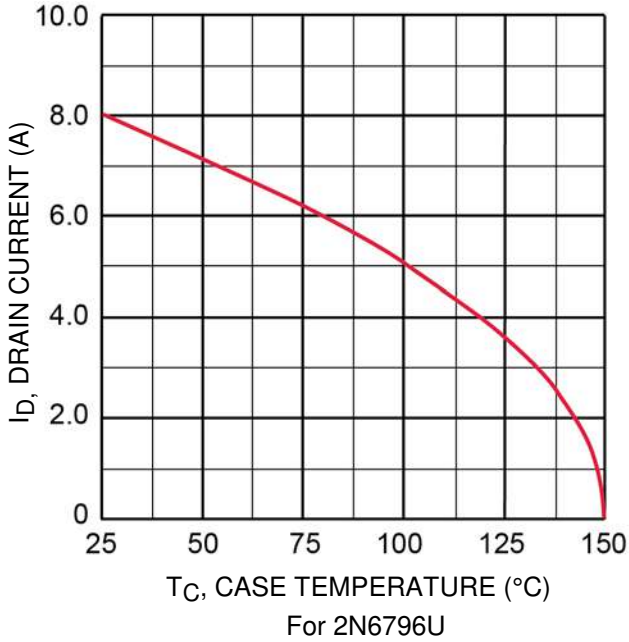
**GRAPHS (continued)**
**FIGURE 2 – Maximum Drain Current vs Case Temperature Graphs**

GRAPHS (continued)

FIGURE 3 – Maximum Safe Operating Area

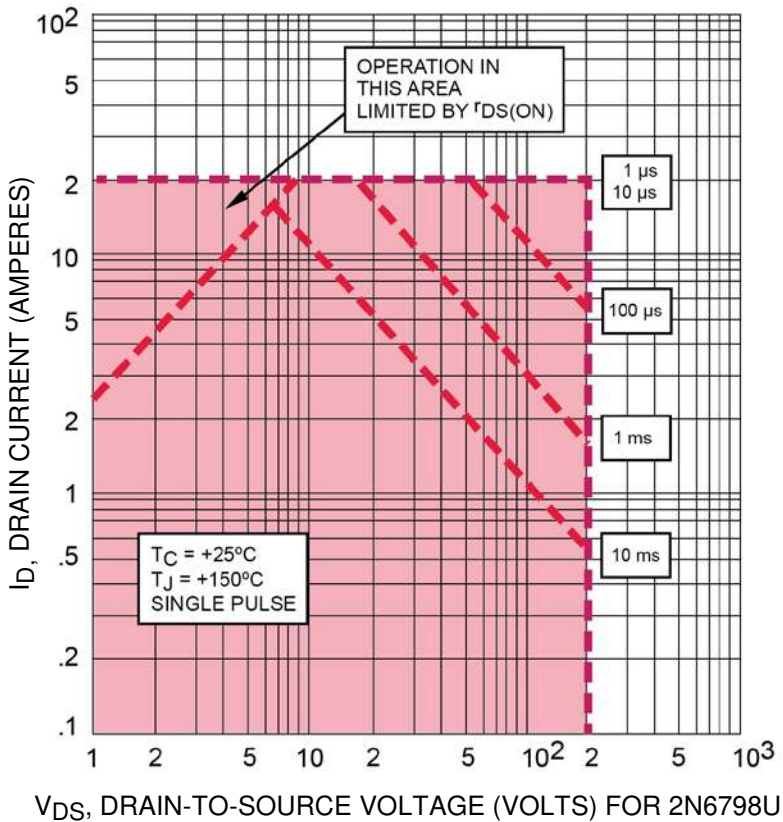
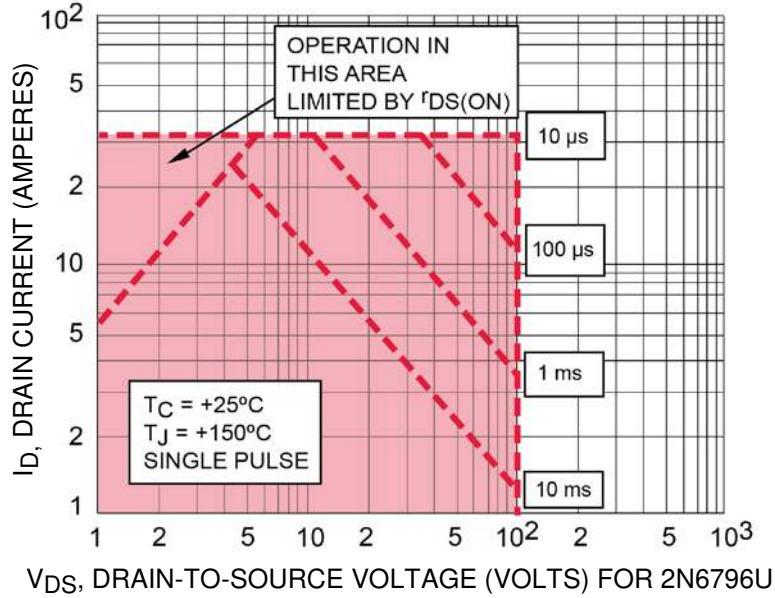

GRAPHS (continued)

FIGURE 3 – Maximum Safe Operating Area (continued)

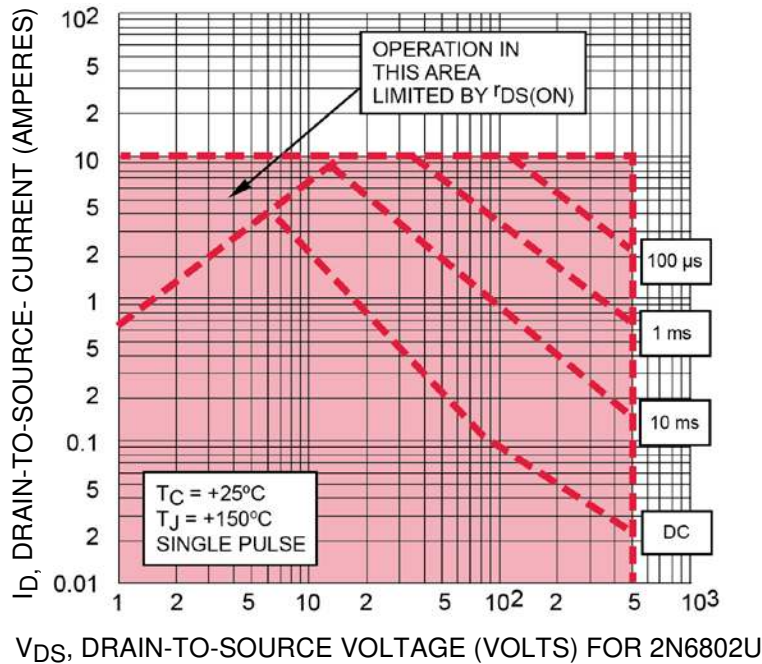
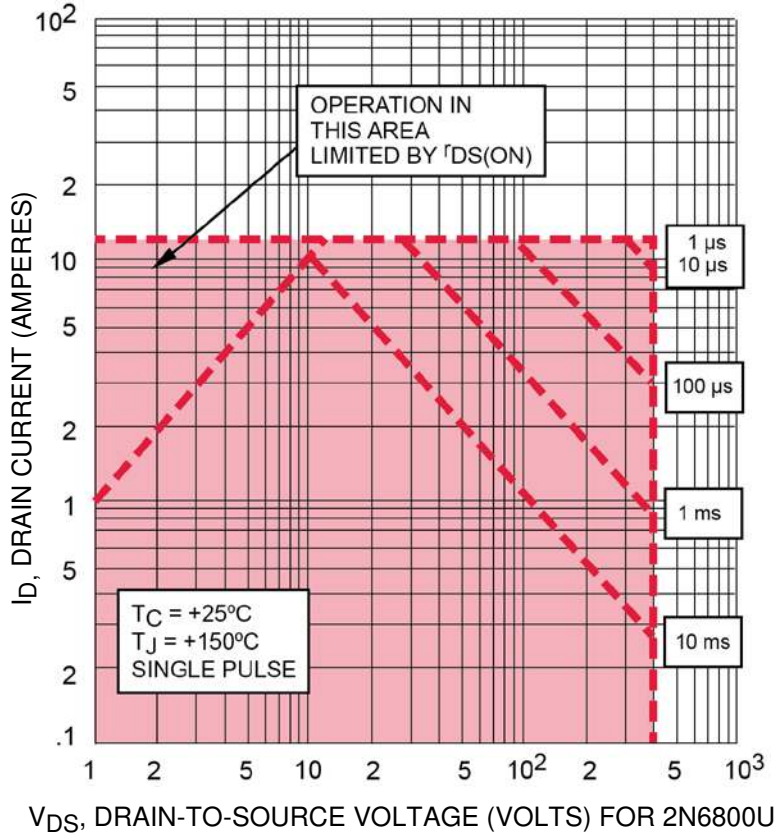



PACKAGE DIMENSIONS

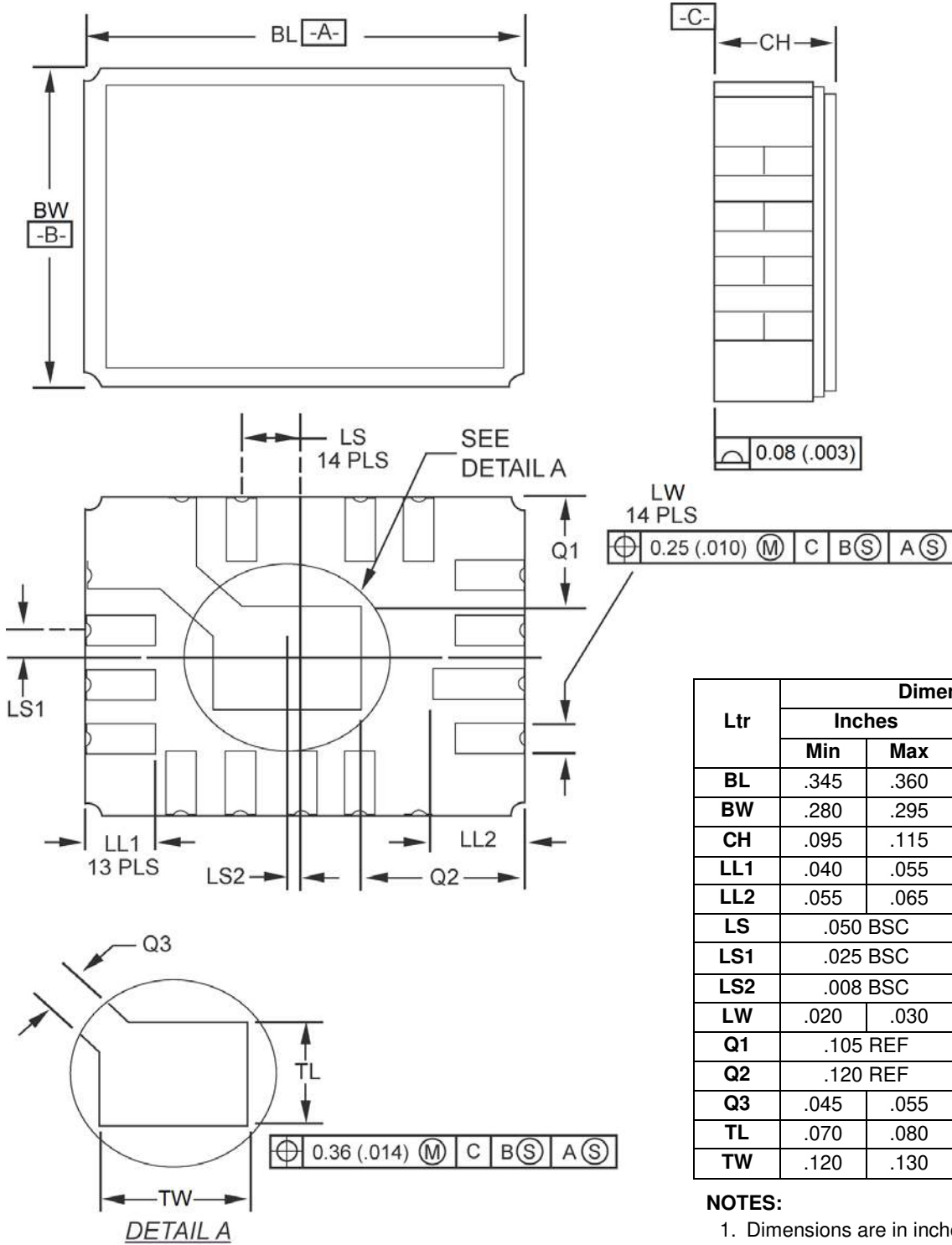

Ltr	Dimensions			
	Inches		Millimeters	
	Min	Max	Min	Max
BL	.345	.360	8.77	9.14
BW	.280	.295	7.12	7.49
CH	.095	.115	2.42	2.92
LL1	.040	.055	1.02	1.39
LL2	.055	.065	1.40	1.65
LS	.050 BSC		1.27 BSC	
LS1	.025 BSC		0.635 BSC	
LS2	.008 BSC		0.203 BSC	
LW	.020	.030	0.51	0.76
Q1	.105 REF		2.67 REF	
Q2	.120 REF		3.05 REF	
Q3	.045	.055	1.14	1.40
TL	.070	.080	1.78	2.03
TW	.120	.130	3.05	3.30

NOTES:

1. Dimensions are in inches.
2. Millimeters are given for general information only.
3. In accordance with ASME Y14.5M, diameters are equivalent to  $\Phi$  symbology.
4. Ceramic package only.

**PAD LAYOUT**

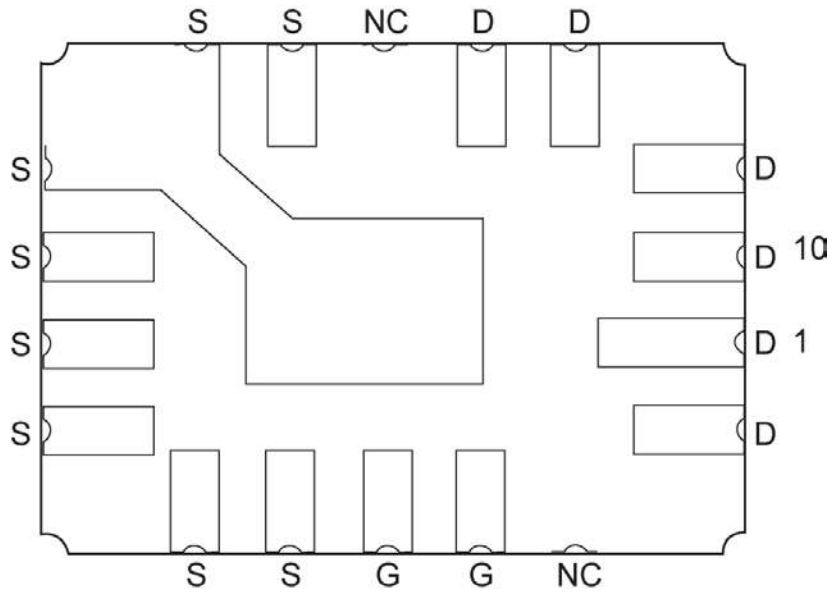

**PAD ASSIGNMENTS**