



MICROCHIP

**dsPIC33EP128GS808
Development Board
User's Guide**

Note the following details of the code protection feature on Microchip devices:

- Microchip products meet the specification contained in their particular Microchip Data Sheet.
- Microchip believes that its family of products is one of the most secure families of its kind on the market today, when used in the intended manner and under normal conditions.
- There are dishonest and possibly illegal methods used to breach the code protection feature. All of these methods, to our knowledge, require using the Microchip products in a manner outside the operating specifications contained in Microchip's Data Sheets. Most likely, the person doing so is engaged in theft of intellectual property.
- Microchip is willing to work with the customer who is concerned about the integrity of their code.
- Neither Microchip nor any other semiconductor manufacturer can guarantee the security of their code. Code protection does not mean that we are guaranteeing the product as "unbreakable."

Code protection is constantly evolving. We at Microchip are committed to continuously improving the code protection features of our products. Attempts to break Microchip's code protection feature may be a violation of the Digital Millennium Copyright Act. If such acts allow unauthorized access to your software or other copyrighted work, you may have a right to sue for relief under that Act.

Information contained in this publication regarding device applications and the like is provided only for your convenience and may be superseded by updates. It is your responsibility to ensure that your application meets with your specifications. MICROCHIP MAKES NO REPRESENTATIONS OR WARRANTIES OF ANY KIND WHETHER EXPRESS OR IMPLIED, WRITTEN OR ORAL, STATUTORY OR OTHERWISE, RELATED TO THE INFORMATION, INCLUDING BUT NOT LIMITED TO ITS CONDITION, QUALITY, PERFORMANCE, MERCHANTABILITY OR FITNESS FOR PURPOSE. Microchip disclaims all liability arising from this information and its use. Use of Microchip devices in life support and/or safety applications is entirely at the buyer's risk, and the buyer agrees to defend, indemnify and hold harmless Microchip from any and all damages, claims, suits, or expenses resulting from such use. No licenses are conveyed, implicitly or otherwise, under any Microchip intellectual property rights unless otherwise stated.

Microchip received ISO/TS-16949:2009 certification for its worldwide headquarters, design and wafer fabrication facilities in Chandler and Tempe, Arizona; Gresham, Oregon and design centers in California and India. The Company's quality system processes and procedures are for its PIC® MCUs and dsPIC® DSCs, KEELOQ® code hopping devices, Serial EEPROMs, microperipherals, nonvolatile memory and analog products. In addition, Microchip's quality system for the design and manufacture of development systems is ISO 9001:2000 certified.

**QUALITY MANAGEMENT SYSTEM
CERTIFIED BY DNV
= ISO/TS 16949 =**

Trademarks

The Microchip name and logo, the Microchip logo, AnyRate, AVR, AVR logo, AVR Freaks, BeaconThings, BitCloud, CryptoMemory, CryptoRF, dsPIC, FlashFlex, flexPWR, Helder, JukeBlox, KEELOQ, KEELOQ logo, Klear, LANCheck, LINK MD, maXStylus, maXTouch, MediaLB, megaAVR, MOST, MOST logo, MPLAB, OptoLyzer, PIC, picoPower, PICSTART, PIC32 logo, Prochip Designer, QTouch, RightTouch, SAM-BA, SpyNIC, SST, SST Logo, SuperFlash, tinyAVR, UNI/O, and XMEGA are registered trademarks of Microchip Technology Incorporated in the U.S.A. and other countries.

ClockWorks, The Embedded Control Solutions Company, EtherSynch, Hyper Speed Control, HyperLight Load, IntelliMOS, mTouch, Precision Edge, and Quiet-Wire are registered trademarks of Microchip Technology Incorporated in the U.S.A.

Adjacent Key Suppression, AKS, Analog-for-the-Digital Age, Any Capacitor, AnyIn, AnyOut, BodyCom, chipKIT, chipKIT logo, CodeGuard, CryptoAuthentication, CryptoCompanion, CryptoController, dsPICDEM, dsPICDEM.net, Dynamic Average Matching, DAM, ECAN, EtherGREEN, In-Circuit Serial Programming, ICSP, Inter-Chip Connectivity, JitterBlocker, KlearNet, KlearNet logo, Mindi, MiWi, motorBench, MPASM, MPF, MPLAB Certified logo, MPLIB, MPLINK, MultiTRAK, NetDetach, Omniscient Code Generation, PICDEM, PICDEM.net, PICkit, PICTail, PureSilicon, QMatrix, RightTouch logo, REAL ICE, Ripple Blocker, SAM-ICE, Serial Quad I/O, SMART-I.S., SQI, SuperSwitcher, SuperSwitcher II, Total Endurance, TSHARC, USBCheck, VariSense, ViewSpan, WiperLock, Wireless DNA, and ZENA are trademarks of Microchip Technology Incorporated in the U.S.A. and other countries.

SQTP is a service mark of Microchip Technology Incorporated in the U.S.A.

Silicon Storage Technology is a registered trademark of Microchip Technology Inc. in other countries.

GestIC is a registered trademark of Microchip Technology Germany II GmbH & Co. KG, a subsidiary of Microchip Technology Inc., in other countries.

All other trademarks mentioned herein are property of their respective companies.

© 2017, Microchip Technology Incorporated, All Rights Reserved.

ISBN: 978-1-5224-1406-3

Object of Declaration: dsPIC33EP128GS808 Development Board

EU Declaration of Conformity

This declaration of conformity is issued by the manufacturer.

The development/evaluation tool is designed to be used for research and development in a laboratory environment. This development/evaluation tool is not a Finished Appliance, nor is it intended for incorporation into Finished Appliances that are made commercially available as single functional units to end users under EU EMC Directive 2004/108/EC and as supported by the European Commission's Guide for the EMC Directive 2004/108/EC (8th February 2010).

This development/evaluation tool complies with EU RoHS2 Directive 2011/65/EU.

This development/evaluation tool, when incorporating wireless and radio-telecom functionality, is in compliance with the essential requirement and other relevant provisions of the R&TTE Directive 1999/5/EC and the FCC rules as stated in the declaration of conformity provided in the module datasheet and the module product page available at www.microchip.com.

For information regarding the exclusive, limited warranties applicable to Microchip products, please see Microchip's standard terms and conditions of sale, which are printed on our sales documentation and available at www.microchip.com.

Signed for and on behalf of Microchip Technology Inc. at Chandler, Arizona, USA.

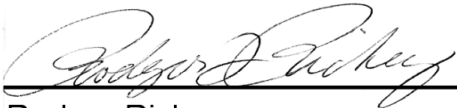

Rodger Richey
Director of Development Tools



Date

dsPIC33EP128GS808 Development Board User's Guide

NOTES:



dsPIC33EP128GS808 DEVELOPMENT BOARD USER'S GUIDE

Table of Contents

Preface	7
Introduction.....	7
Document Layout	7
Conventions Used in this Guide	8
Recommended Reading.....	9
The Microchip Web Site	9
Product Change Notification Service.....	9
Customer Support	9
Document Revision History	9
Chapter 1. Product Overview	
1.1 Introduction	11
1.2 Overview	11
1.3 Development Board Functionality and Features	12
1.4 Electrical Specifications	12
Chapter 2. Hardware	
2.1 Top Assembly	13
2.2 Signal Configuration	15
2.3 Application Components	17
2.4 Board Connectors	17
2.5 Indicators and Human Interfaces	18
2.6 Test Points	19
2.7 Programmer/Debugger	20
Chapter 3. Demonstration Program Operation	
3.1 Hardware Description	21
3.2 Program Demonstration	25
3.3 Code Demonstration	28
3.4 Other Code Examples	30
Appendix A. Board Layout and Schematics.....	31
Worldwide Sales and Service	36

dsPIC33EP128GS808 Development Board User's Guide

NOTES:



dsPIC33EP128GS808 DEVELOPMENT BOARD USER'S GUIDE

Preface

NOTICE TO CUSTOMERS

All documentation becomes dated, and this manual is no exception. Microchip tools and documentation are constantly evolving to meet customer needs, so some actual dialogs and/or tool descriptions may differ from those in this document. Please refer to our web site (www.microchip.com) to obtain the latest documentation available.

Documents are identified with a “DS” number. This number is located on the bottom of each page, in front of the page number. The numbering convention for the DS number is “DSXXXXXXXXA”, where “XXXXXXXX” is the document number and “A” is the revision level of the document.

For the most up-to-date information on development tools, see the MPLAB® IDE online help. Select the Help menu, and then Topics, to open a list of available online help files.

INTRODUCTION

This chapter contains general information that will be useful to know before using the dsPIC33EP128GS808 Development Board. Items discussed in this chapter include:

- [Document Layout](#)
- [Conventions Used in this Guide](#)
- [Recommended Reading](#)
- [The Microchip Web Site](#)
- [Customer Support](#)
- [Document Revision History](#)

DOCUMENT LAYOUT

This document describes how to use the dsPIC33EP128GS808 Development Board as a development tool to emulate and debug firmware on a target board. The manual layout is as follows:

- Product Overview – This chapter introduces the dsPIC33EP128GS808 Development Board and provides an overview of its features.
- Hardware – This chapter describes the hardware components of the dsPIC33EP128GS808 Development Board.
- Demonstration Program Operation – This chapter includes a program demonstration, code demonstration and code examples for the dsPIC33EP128GS808 Development Board.
- Appendix A – Shows the schematics and board layouts for the dsPIC33EP128GS808 Development Board.

dsPIC33EP128GS808 Development Board User's Guide

CONVENTIONS USED IN THIS GUIDE

This manual uses the following documentation conventions:

DOCUMENTATION CONVENTIONS

Description	Represents	Examples
Arial font:		
Italic characters	Referenced books	<i>MPLAB® IDE User's Guide</i>
	Emphasized text	...is the <i>only</i> compiler...
Initial caps	A window	the Output window
	A dialog	the Settings dialog
	A menu selection	select Enable Programmer
Quotes	A field name in a window or dialog	"Save project before build"
Underlined, italic text with right angle bracket	A menu path	<u><i>File>Save</i></u>
Bold characters	A dialog button	Click OK
	A tab	Click the Power tab
N'Rnnnn	A number in verilog format, where N is the total number of digits, R is the radix and n is a digit.	4'b0010, 2'hF1
Text in angle brackets < >	A key on the keyboard	Press <Enter>, <F1>
Courier New font:		
Plain Courier New	Sample source code	#define START
	Filenames	autoexec.bat
	File paths	c:\mcc18\h
	Keywords	_asm, _endasm, static
	Command-line options	-Opa+, -Opa-
	Bit values	0, 1
	Constants	0xFF, 'A'
Italic Courier New	A variable argument	<i>file.o</i> , where <i>file</i> can be any valid filename
Square brackets []	Optional arguments	mcc18 [options] <i>file</i> [options]
Curly brackets and pipe character: { }	Choice of mutually exclusive arguments; an OR selection	errorlevel {0 1}
Ellipses...	Replaces repeated text	var_name [, var_name...]
	Represents code supplied by user	void main (void) { ... }

RECOMMENDED READING

This quick start guide describes how to use the dsPIC33EP128GS808 Development Board. Other useful documents are listed below. The following Microchip document is available and recommended as a supplemental reference resource:

- “*dsPIC33EPXXXGS70X/80X Family Data Sheet*” (DS70005258)

THE MICROCHIP WEB SITE

Microchip provides online support via our web site at www.microchip.com. This web site is used as a means to make files and information easily available to customers. Accessible by using your favorite Internet browser, the web site contains the following information:

- **Product Support** – Data sheets and errata, application notes and sample programs, design resources, user’s guides and hardware support documents, latest software releases and archived software
- **General Technical Support** – Frequently Asked Questions (FAQs), technical support requests, online discussion groups, Microchip consultant program member listing
- **Business of Microchip** – Product selector and ordering guides, latest Microchip press releases, listing of seminars and events, listings of Microchip sales offices, distributors and factory representatives

PRODUCT CHANGE NOTIFICATION SERVICE

Microchip’s customer notification service helps keep customers current on Microchip products. Subscribers will receive e-mail notifications whenever there are changes, updates, revisions or errata related to a specified product family or development tool of interest.

To register, access the Microchip web site at www.microchip.com, click on **Product Change Notification** and follow the registration instructions.

CUSTOMER SUPPORT

Users of Microchip products can receive assistance through several channels:

- Distributor or Representative
- Local Sales Office
- Embedded Solutions Engineer (ESE)
- Technical Support

Customers should contact their distributor, representative or Embedded Solutions Engineer (ESE) for support. Local sales offices are also available to help customers. A listing of sales offices and locations is included in the back of this document.

Technical support is available through the web site at:
<http://www.microchip.com/support>.

DOCUMENT REVISION HISTORY

Revision A (June 2017)

- Initial Release of this Document.

dsPIC33EP128GS808 Development Board User's Guide

NOTES:



dsPIC33EP128GS808 DEVELOPMENT BOARD USER'S GUIDE

Chapter 1. Product Overview

1.1 INTRODUCTION

This chapter introduces the dsPIC33EP128GS808 Development Board and provides an overview of its features. The topics covered include:

- [Overview](#)
- [Development Board Functionality and Features](#)
- [Electrical Specifications](#)

1.2 OVERVIEW

The dsPIC33EP128GS808 Development Board (referred to as development board) is designed to aid in the evaluation and development of firmware for the dsPIC33EP 'GS' family of Digital Signal Controllers (DSCs). There are 3 primary objectives for development of this board:

- Evaluation of peripherals and core features of the GS family
- Support for dual CAN solutions with the *"CAN/LIN/J2602 PICtail™ (Plus) Daughter Board User's Guide"* (DS70319)
- Demonstration of emulated power supply transient response

The development board can be used as a stand-alone platform for evaluating DSC core features, such as throughput and device peripherals, which include ADC, PWM, PGA, CMP, SPI, I²C, etc. [Table 2-3](#) provides a comprehensive list of I/O signals available for evaluation. Note that the remappable I/Os provide additional flexibility to access additional signals on the I/O pins. Refer to the *"dsPIC33EPXXXGS70X/80X Family Data Sheet"* (DS70005258) for further details.

The development board provides support for development of dual CAN applications, along with the CAN/LIN/J2602 PICtail (Plus) Daughter Board. The CAN/LIN/J2602 PICtail (Plus) Daughter Board consists of 2 sets of CAN drivers and 2 sets of LIN drivers. The development board plugs into the PICtail board and allows development of CAN or LIN communication.

The development board contains multiple first-order RC filters to emulate power supply functionality. The board can be operated in Open or Closed-Loop mode. Furthermore, there is additional hardware on the board to simulate power supply transient behavior. The board can be powered with a standard 9V adapter or through the mini-USB. The board can be programmed with standard Microchip programming tools via an RJ25 connector and contains LEDs, switch, selectable jumpers for maximizing peripheral interconnectivity, potentiometers and analog feedback networks, all of which help to facilitate development of firmware on the dsPIC33EP 'GS' devices.

1.3 DEVELOPMENT BOARD FUNCTIONALITY AND FEATURES

The dsPIC33EP128GS808 Development Board allows users to evaluate the features of dsPIC33EP 'GS' series devices. The dsPIC33EP 'GS' devices offer new peripherals and features that can be explored using the development board. Configurable connectors make it easy to connect different peripherals together to test features that would otherwise require additional hardware. The development board can also be used to develop dual CAN communication systems when used along with the CAN/LIN/J2602 PICtail (Plus) Daughter Board.

The development board provides the following features:

- Dual CAN/LIN Interface:
 - Used as an add-on board to the CAN/LIN/J2602 PICtail (Plus) Daughter Board
 - Interfaces with CAN and LIN drivers on the CAN/LIN/J2602 PICtail (Plus) Daughter Board
 - Provides power to CAN and LIN drivers on the CAN/LIN/J2602 PICtail (Plus) Daughter Board
- Power Supply Simulation Using First-Order Filters:
 - Separate voltage and current loop emulation
 - Provision to simulate dynamic response
 - Multiple first-order filters on board, selectable by jumpers
 - Ramp generator circuit
 - Constant-current test circuit
- General Features:
 - External voltage input provision
 - Debug switch and LEDs
 - On-board power supply – operates from 9V input
 - Optional USB power
 - RJ25 connector programming interface
 - PICKIT™ 3 serial analyzer

1.4 ELECTRICAL SPECIFICATIONS

TABLE 1-1: DC INPUT RATING (J1)

Parameter	Minimum	Typical	Maximum	Units	Remarks
Voltage	7.0	9	11	V	9V Adapter
Current	0.2	—	—	A	Stand-Alone Mode
	—	—	0.7	A	With CAN/LIN Operating on the PICtail™ Board

Chapter 2. Hardware

This chapter describes the hardware components of the dsPIC33EP128GS808 Development Board. The topics covered include:

- [Top Assembly](#)
- [Signal Configuration](#)
- [Application Components](#)
- [Board Connectors](#)
- [Indicators and Human Interfaces](#)
- [Test Points](#)
- [Programmer/Debugger](#)

2.1 TOP ASSEMBLY

The top and bottom assemblies of the board are shown in [Figure 2-1](#) and [Figure 2-2](#). [Table 2-1](#) and [Table 2-2](#) provide a description of the components.

FIGURE 2-1: DEVELOPMENT BOARD COMPONENTS (TOP)

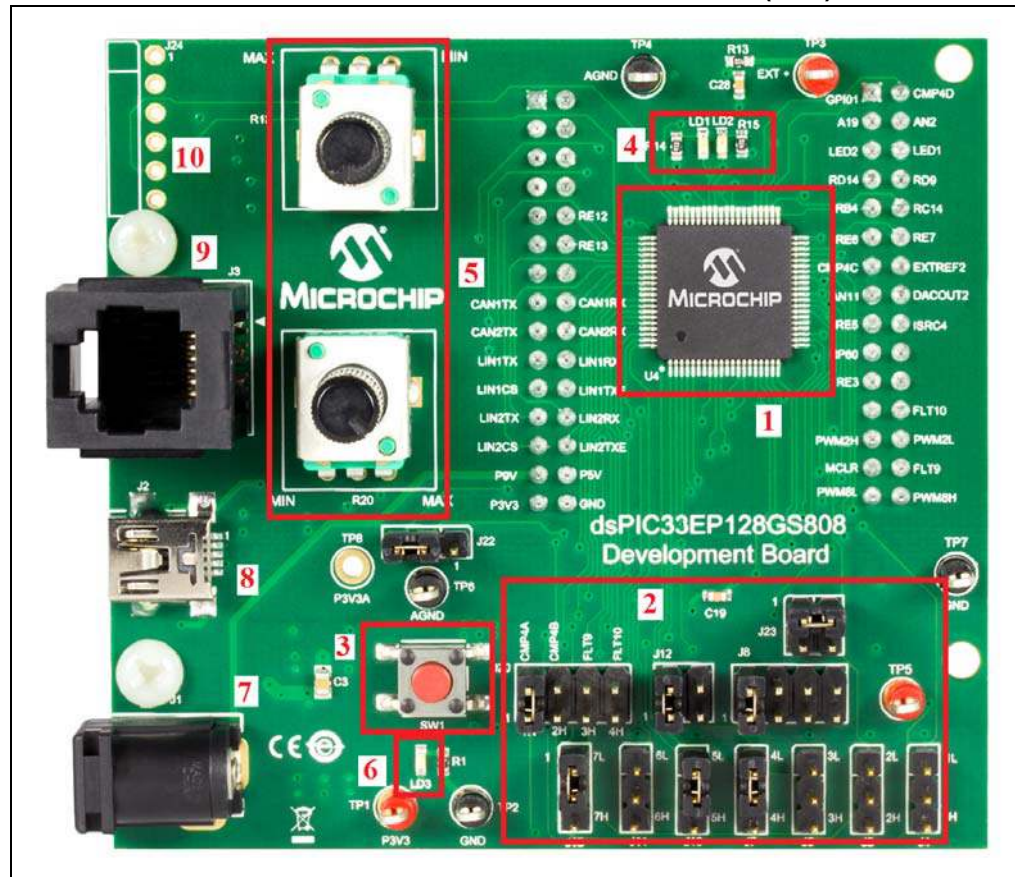

dsPIC33EP128GS808 Development Board User's Guide

TABLE 2-1: DEVELOPMENT BOARD COMPONENTS (TOP)

Number	Description
1	dsPIC33EP128GS808
2	Configurable Jumpers
3	Switch (SW1)
4	Diagnostic LEDs
5	Potentiometers
6	Power LED
7	9V Power Connector (J1)
8	USB Connector (J2)
9	Programming Connector
10	PICKit™ 3 Serial Analyzer (J24)

FIGURE 2-2: DEVELOPMENT BOARD COMPONENTS (BOTTOM)

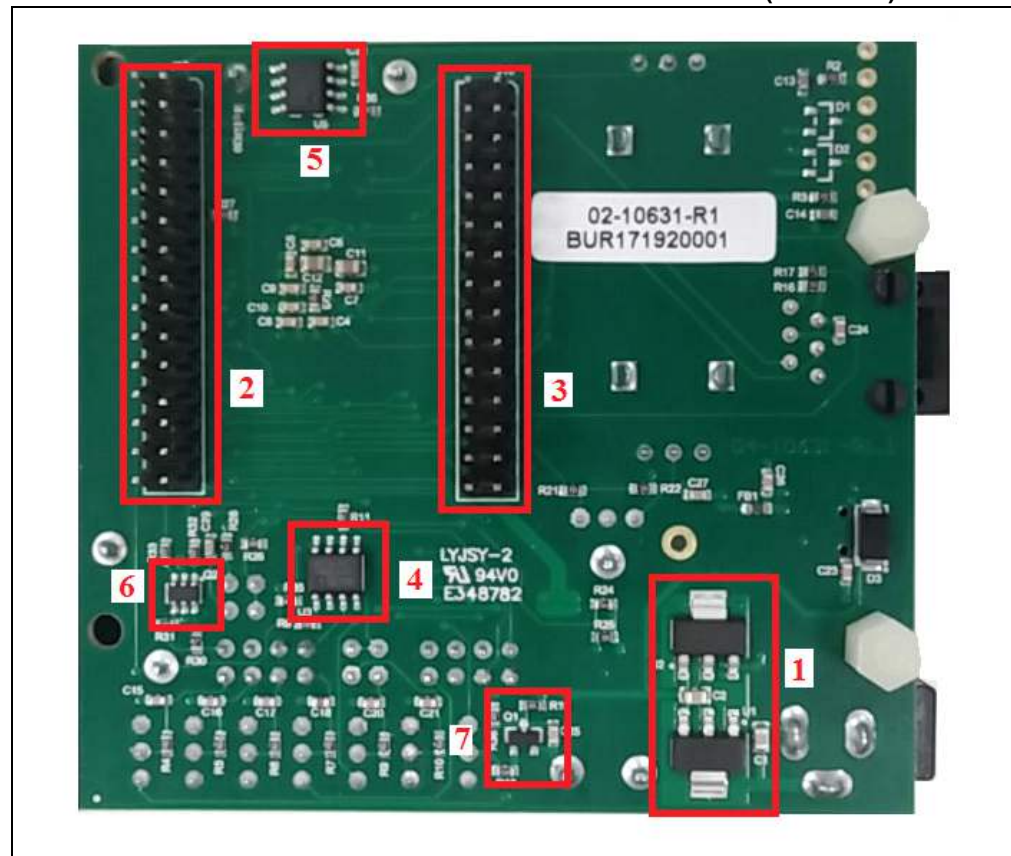

TABLE 2-2: DEVELOPMENT BOARD COMPONENTS (BOTTOM)

Number	Description
1	Voltage Regulators
2	Connector J17
3	Connector J18
4	Op Amp U3
5	Op Amp U5
6	MOSFET Q2
7	MOSFET Q1

2.2 SIGNAL CONFIGURATION

Table 2-3 provides a full list of the dsPIC33EP 'GS' DSC connections and a brief functional description of the pins used on the development board.

TABLE 2-3: dsPIC33 PIN CONFIGURATION DETAILS

Development Board Signal Label	Device Pin #	Device Pin Function	Description
PWM4L	1	PWM4L	PWM Output
PWM1H	2	PWM1H	PWM Output
PWM1L	3	PWM1L	PWM Output
PWM8L	4	PWM8L	PWM Output
PWM8H	5	PWM8H	PWM Output
RP48	6	CAN1TX	CAN1 Transmit
RP61	7	CAN1RX	CAN1 Receive
FLT10	8	FLT10	Fault Signal, I/O
$\overline{\text{MCLR}}$	9	$\overline{\text{MCLR}}$	Reset Signal
FLT9	10	FLT9	Fault Signal, I/O
Vss	11	Vss	3.3V Return
VDD	12	VDD	3.3V
RE2	13	RE2	I/O
RE3	14	RE3	I/O
AVDD	15	AVDD	Filtered 3.3V
RP60	16	RP60	Reconfigurable Pin
AN0	17	AN0	Analog ADC Input
AN1	18	AN1	Analog ADC Input
AN2	19	AN2	Analog ADC Input
AN3	20	AN3	Analog ADC Input
ISRC4	21	ISRC4	Current Source Input
RE4	22	SW1	Switch Input
RE5	23	RE5	I/O
AVDD	24	AVDD	Filtered 3.3V
AVDD	25	AVDD	Filtered 3.3V
AVss	26	AVss	Filtered 3.3V Return
AN15	27	AN15	Analog ADC Input
DACOUT2	28	DACOUT2	DAC Output
AN11	29	AN11	Analog ADC Input
EXTREF2	30	EXTREF2	External ADC Reference Voltage
Vss	31	Vss	3.3V Return
VDD	32	VDD	3.3V
CMP4C	33	CMP4C	Comparator Input
CMP4A	34	CMP4A	Comparator Input
CMP4B	35	CMP4B	Comparator Input
AN16	36	AN16	Analog ADC Input
RE6	37	RE6	I/O
RE7	38	RE7	I/O
RP63	39	LIN1RX	LIN1 Receive

dsPIC33EP128GS808 Development Board User's Guide

TABLE 2-3: dsPIC33 PIN CONFIGURATION DETAILS (CONTINUED)

Development Board Signal Label	Device Pin #	Device Pin Function	Description
DACOUT1	40	DACOUT1	DAC Output
RB4	41	RB4	I/O
RC14	42	RC14	I/O
RE8	43	GPIO1	I/O
RE9	44	GPIO2	I/O
CMP4D	45	CMP4D	Comparator Input
RP55	46	CAN2TX	CAN2 Transmit
RP56	47	CAN2RX	CAN2 Receive
VDD	48	VDD	3.3V
RD14	49	RD14	I/O
RD9	50	RD9	I/O
VSS	51	VSS	3.3V Return
RE10	52	LED2	LED Control Signal
RE11	53	LED1	LED Control Signal
RP72	54	LIN1TX	LIN1 Transmit
PGED3/SD2	55	PGED3	Programmer Interface for J3
PGEC3/SCL2	56	PGEC3	Programmer Interface for J3
RP75	57	LIN1TXE	LIN1 Transmit Enable
AN19	58	AN19	Analog ADC Input
RP64	59	LIN1CS	LIN1 Control Signal
PGED1/SCL1	60	SCL1	PICKIT™ Serial Analyzer
PGEC1/SDA1	61	SDA1	PICKIT Serial Analyzer
RP52	62	LIN2CS	LIN2 Control Signal
RE12	63	RE12	I/O
RE13	64	RE13	I/O
RP53	65	LIN2TX	LIN2 Transmit
RP54	66	LIN2RX	LIN2 Receive
RP69	67	LIN2TXE	LIN2 Transmit Enable
PWM5H	68	PWM5H	PWM Output
PWM5L	69	PWM5L	PWM Output
VCAP	70	VCAP	Core Voltage
VDD	71	VDD	3.3V
PWM6H	72	PWM6H	PWM Output
PWM6L	73	PWM6L	PWM Output
PWM7L	74	PWM7L	PWM Output
PWM7H	75	PWM7H	PWM Output
PWM3H	76	PWM3H	PWM Output
PWM3L	77	PWM3L	PWM Output
PWM2H	78	PWM2H	PWM Output
PWM2L	79	PWM2L	PWM Output
PWM4H	80	PWM4H	PWM Output

2.3 APPLICATION COMPONENTS

Table 2-4 describes the application components that are available on the dsPIC33EP128GS808 Development Board (see Figure 2-1 and Figure 2-2 for component locations).

TABLE 2-4: COMPONENT DETAILS

Component	Label	Description
Top Assembly Components (see Figure 2-1)		
Microcontroller (DSC)	U4	Main Controller
Configurable Jumpers	Jx	Jumpers for Selecting Various Inputs
Switch	SW1	Switch Input
Diagnostic LEDs	LD1, LD2	LEDs for Diagnostics
Potentiometers	R12, R20	Variable Input Voltage to Controller
Power LED	LD3	Power Indicator
Input Power Connector	J1	9V DC Input
USB Connector	J2	USB Power Connection
Programming Connector	J3	Connection to Programmer/Debugger
PICKit™ Serial Analyzer	J24	Communication Interface (not mounted)
Bottom Assembly Components (see Figure 2-2)		
Voltage Regulator	U1	Converts 9V DC Input to 5V
Voltage Regulator	U2	Converts 5V DC Input to 3.3V
Op Amp	U3	Used as a Buffer or Summing Node
Op Amp	U5	Used as a Buffer
MOSFET	Q1	Switch for Generating a Ramp Signal
MOSFET	Q2	Switch for Generating Transient Loading
Interface Connector	J17	CAN/LIN Interface with PICtail™ Plus
Interface Connector	J18	CAN/LIN Interface with PICtail Plus

2.4 BOARD CONNECTORS

Table 2-5 describes the hardware connections available on the development board (see Figure 2-1 and Figure 2-2 for component locations).

TABLE 2-5: CONNECTOR DETAILS

Label	Description
J1	9V DC Input
J2	USB Connection for Powering the Board (provides 5V DC input)
J3	J25 Connector to Provide External Programmer/Debugger Interface
J24	PICKit™ 3 Serial Analyzer Communication Interface (not mounted)

2.5 INDICATORS AND HUMAN INTERFACES

Table 2-6 describes the user interfaces available on the development board kit.

TABLE 2-6: HUMAN INTERFACE DETAILS

Label	Description
SW1	Switch Input.
LD1	Diagnostic Green LED.
LD2	Diagnostic Red LED.
LD3	Green LED Power Indicator.
R12	Potentiometer to Provide Variable Voltage (0-3.3V) to Controller I/O Pins.
R20	Potentiometer to Provide Variable Voltage (0-3.3V) to Controller I/O Pins.
J4	Selects PWM1H or PWM1L as an Input to the RC Filter.
J5	Selects PWM2H or PWM2L as an Input to the RC Filter.
J6	Selects PWM3H or PWM3L as an Input to the RC Filter.
J7	Selects PWM4H or PWM4L as an Input to the RC Filter.
J8	Selects PWM1-4 Passed through an RC Filter as Input to the Op Amp Buffer. The Circuit Emulates Output of a Switched Mode Power Supply (SMPS). Multiple PWMs can be Selected if Necessary.
J10	Selects PWM5H or PWM5L as an Input to the RC Filter.
J11	Selects PWM6H or PWM6L as an Input to the RC Filter.
J12	Selects PWM5-6 Passed through an RC Filter as Input to the Op Amp Buffer. The Circuit Emulates Output of a Switched Mode Power Supply (SMPS). Both PWMs can be Selected if Necessary.
J15	Selects PWM7H or PWM7L as an Input to the Ramp Generator Circuit.
J20	Allows Connection of PWM Signals to Comparator or Fault Inputs.
J22	Connects a Variable Voltage Generated by Potentiometer R20 or DACOUT2.
J23	Connects Current Source to a Resistive or Capacitive Load.

2.6 TEST POINTS

Table 2-7 describes the test points that are available on the development board. See Figure 2-3 for test point locations.

TABLE 2-7: TEST POINTS

Label	Description
TP1	3.3V (P3V3)
TP2	3.3V Return (GND)
TP3	External 3.3V Input to ADC
TP4	External 3.3V Return (AGND)
TP5	Buffer Output from RC Filters
TP6	Filtered 3.3V Return (AGND)
TP7	3.3V Return (GND)
TP8	Filtered 3.3V (P3V3A) (not mounted on board)

FIGURE 2-3: TEST POINT LOCATIONS

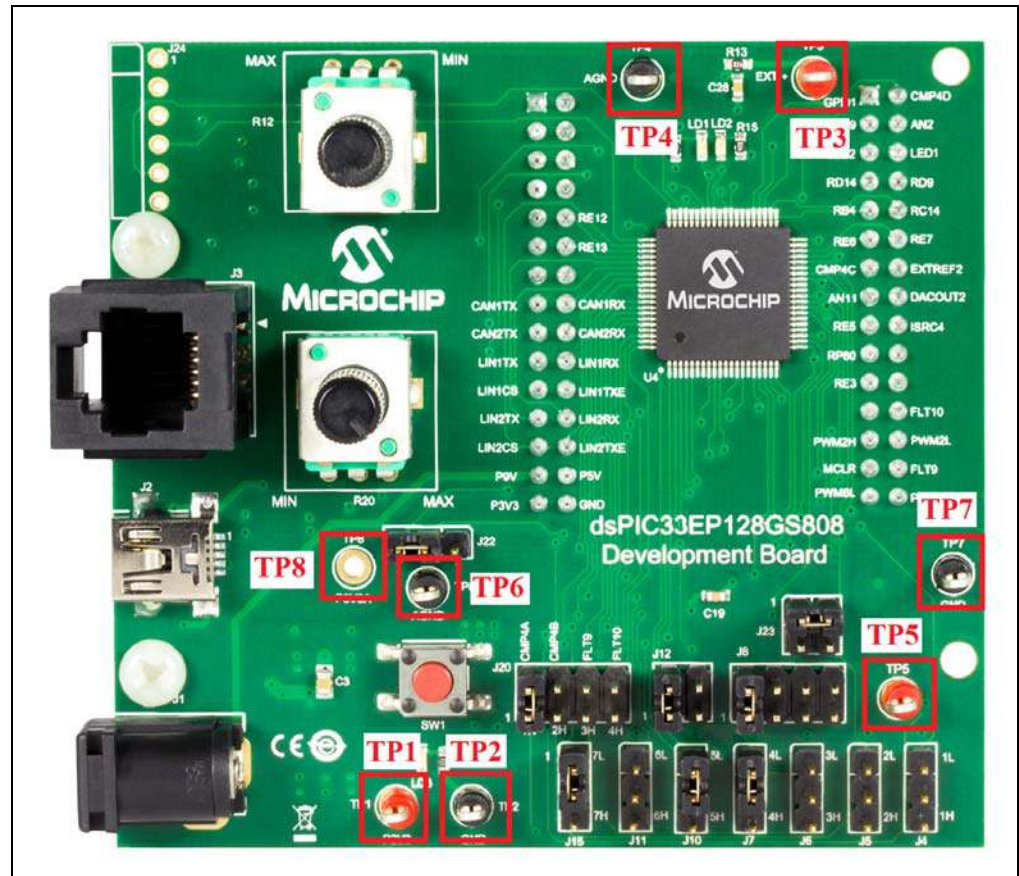

2.7 PROGRAMMER/DEBUGGER

The development board needs an external programmer/debugger, such as the MPLAB® ICD 3 or REAL ICE™ emulator to program the controller on the board.

TABLE 2-8: PROGRAMMER/DEBUGGER COMPONENTS

Component	Label	
Programmer/Debugger Connector	J3	RJ25 Connection for Interface to MPLAB® ICD 3 (DV164035)/REAL ICE™ Emulator (DV244005)

Chapter 3. Demonstration Program Operation

The dsPIC33EP128GS808 Development Board is preprogrammed with application software that emulates the closed-loop operation of a power supply. The program illustrates 2-Pole, 2-Zero (2P2Z) compensator control of the output voltage for the power supply emulation circuit. This code can be downloaded from Microchip web site (www.microchip.com).

This section covers the following topics:

- [Hardware Description](#)
- [Software Demonstration](#)
- [Code Demonstration](#)
- [Other Code Examples](#)

3.1 HARDWARE DESCRIPTION

The hardware on the development board emulates the behavior of a power supply. Most of the power supply topologies consist of 2nd order Inductor-Capacitor (LC) filters, which smooth out the high-frequency switching content from the output voltage, resulting in a DC output voltage. The controller monitors the output voltage, compares it with a reference voltage and generates the required PWM duty cycle to maintain the output voltage equal to the reference voltage. The switching frequency is fixed and the output voltage regulation is maintained by controlling the on time of the switch. The ratio of the on time to the total switch duration is known as the duty cycle. The DSC implements a digital compensator, with the voltage error as input and the duty cycle as output. The development board does not use any inductor, but relies on the single-order RC filter and PWM to emulate the power stage of the supply. [Figure 3-1](#) shows the hardware used for emulating the power supply.

FIGURE 3-1: EMULATED POWER SUPPLY HARDWARE

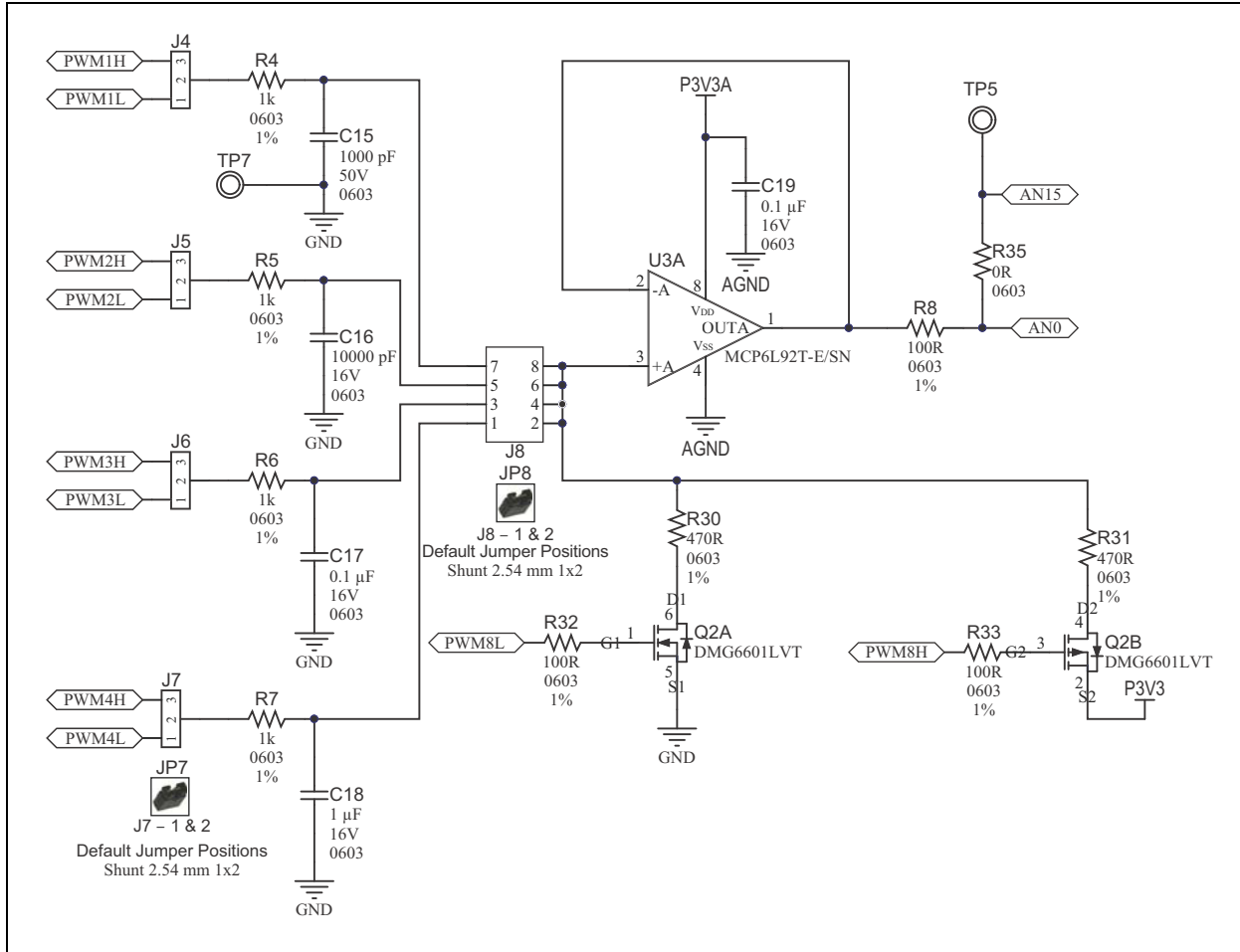

The power section on the board consists of one of the PWM outputs, depending on the jumper installed. The default jumper position uses the JP7 jumper between Pins 1 and 2, and JP8 between Pins 1 and 2. JP7 selects PWM4L as the input to the RC circuit, while JP8 connects the output of the RC filter to the input of the U3-A buffer. The PWM signal, together with the RC filter, forms a power stage. Note the difference in the RC filter values connected to jumper J8. The capacitor value changes by a factor of 10 and can be used to emulate power supplies with a wide range of switching frequencies. The output voltage can be monitored at test point, TP5. The range of the output voltage varies from 0-3.3V, depending upon the reference voltage and PWM duty cycle. The output voltage is connected to the ADC input, AN0. The DSC computes the duty cycle based on the output voltage sample by using a digitized version of a 2P2Z filter. The duty cycle controls the on time, during which, the output of the PWM pin is at 3.3V and at 0V for the rest of the duration. The PWM output generates a near DC value when passed through an RC filter.

Demonstration Program Operation

The load current in a power supply is dependent on the external load impedance and could be constant or varying. The real test for a power supply is when the load transitions from 0% to 100% or from 100% to 0% of rated current values. In a non-regulated power supply, a load transition leads to a drastic fall/rise in the output voltage. However, in a well regulated closed-loop system, a load transient will lead to a smaller output voltage drop (rise) when transitioning from 0 to 100% (100 to 0%), depending on the control design. The development board has additional hardware provided by the Q2 MOSFET to emulate the power supply loading condition. The Q2A and Q2B MOSFETS are controlled by signals PWM8L and PWM8H respectively. Q2A is connected between the buffer input and GND, while Q2B is connected between the buffer input and 3.3V. When Q2A is turned on, the buffer input gets pulled down to GND through the R30 resistor. Depending on the duration of the PWM8L pulse, the output voltage is pulled down from its steady-state value, thereby emulating a 0 to 100% loading condition. Figures 3-2 and 3-3 indicate the transient loading condition. The green waveform corresponds to the PWM4L signal and the blue waveform to the buffer output (TP5) in the following figures.

FIGURE 3-2: 0 TO 100% LOADING CONDITION

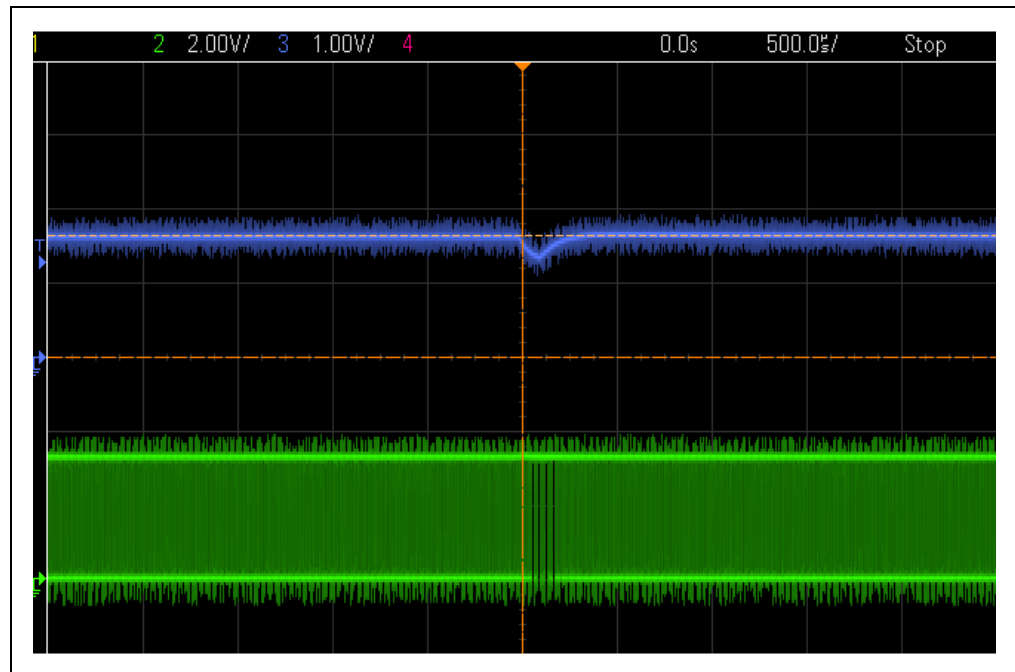
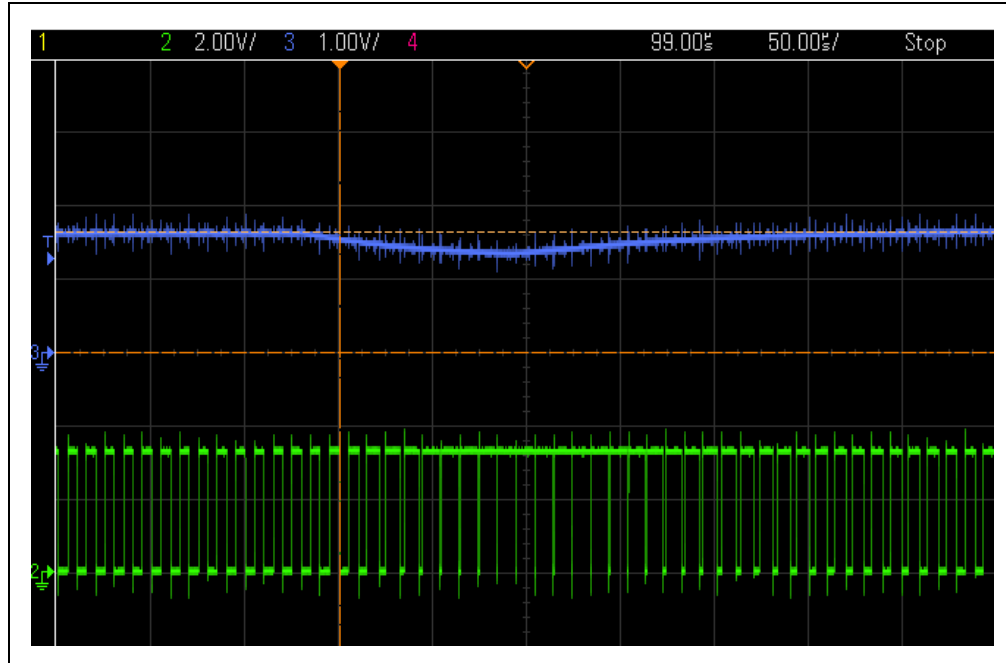

FIGURE 3-3: 0 TO 100% LOADING CONDITION



A load throw effect is seen when the load is suddenly switched off. During this condition, the output voltage rises. When PWM8H is turned on for a small duration, the input buffer gets connected to 3.3V through the R31 resistor. The output voltage subsequently rises, as seen from [Figure 3-4](#) and [Figure 3-5](#). The control loop tries to correct the situation by changing the duty cycle.

FIGURE 3-4: 100 TO 0% LOADING CONDITION

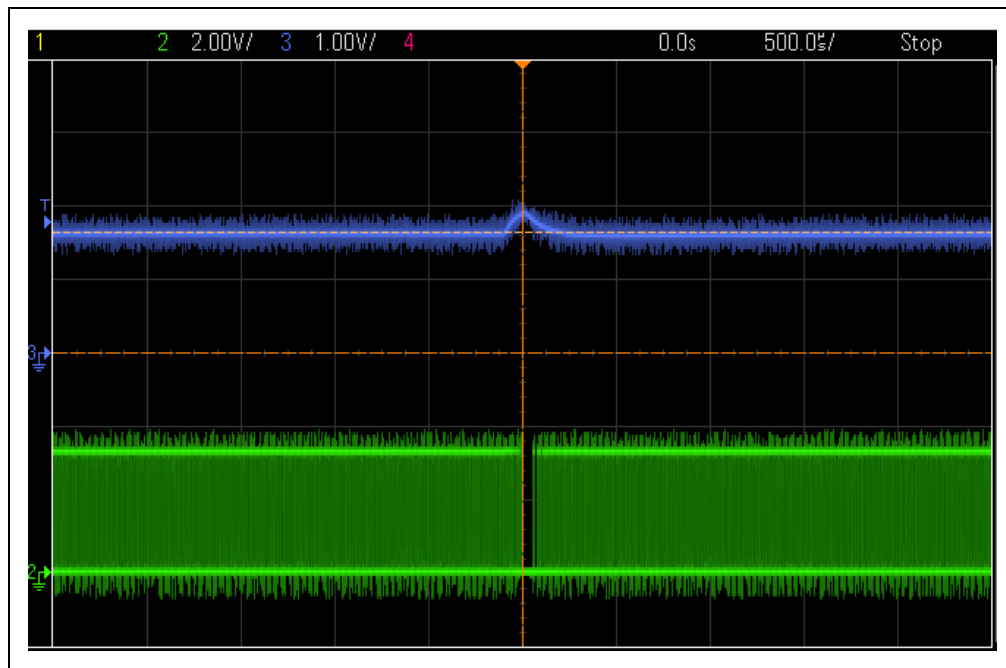
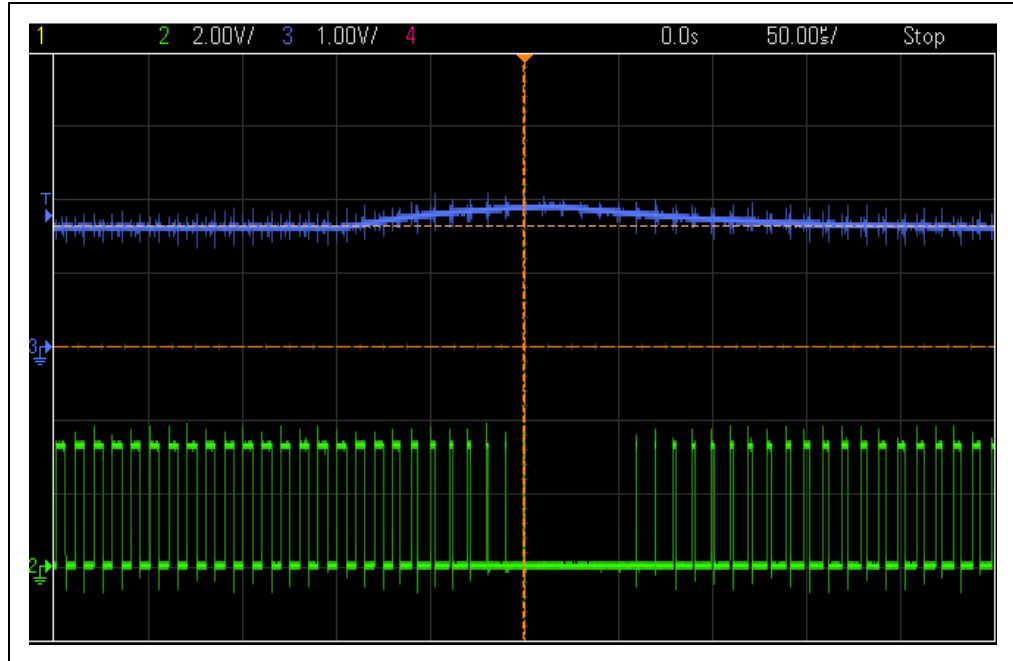

FIGURE 3-5: 100 TO 0% LOADING CONDITION (ZOOMED)



There are additional features on the board, such as a second power loop (PWM5-6 and U3-B) and a ramp generator (Q1), which can be used for demonstrating the Current mode control of the power supply.

3.2 SOFTWARE DEMONSTRATION

The demonstration software provides closed-loop control of the output voltage. The 2P2Z control loop controls the converter output voltage based on the reference voltage set by potentiometer R12. The switching frequency is fixed and set to 100 kHz.

The 2P2Z control scheme consists of the following parameters:

- Reference – Desired set point for the output voltage
- Error – Calculation of (Reference – Feedback)
- System Plant – This is the converter being controlled
- Output – Output voltage or current
- Feedback – The measured output signal level

The demonstration program requires no manual preparation except to connect 9V to the J1 connector or connecting a USB cable to connector J2 with the other end connected to a laptop.

dsPIC33EP128GS808 Development Board User's Guide

FIGURE 3-6: VOLTAGE MODE CONTROL BLOCK DIAGRAM

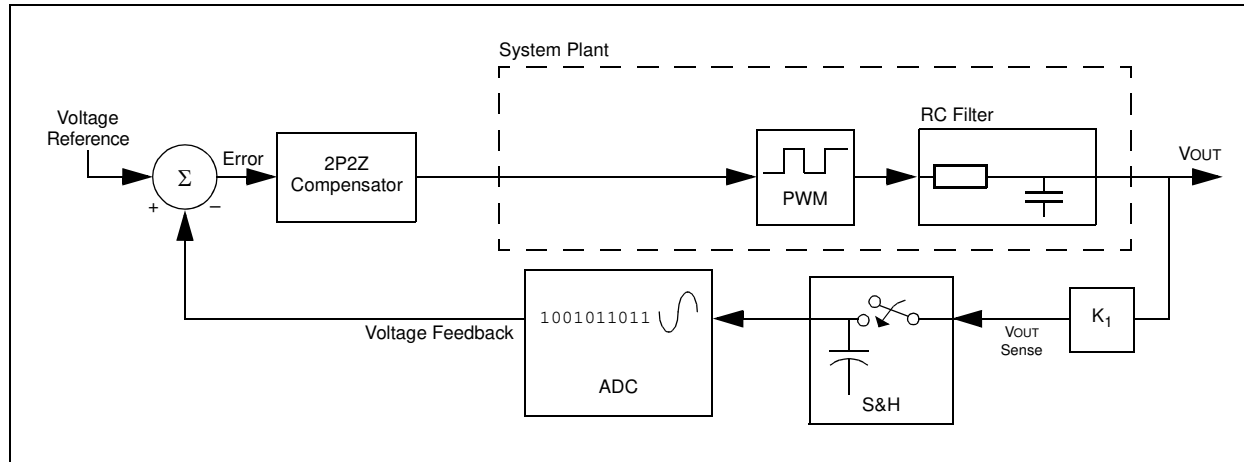

FIGURE 3-7: PROGRAM FLOWCHART

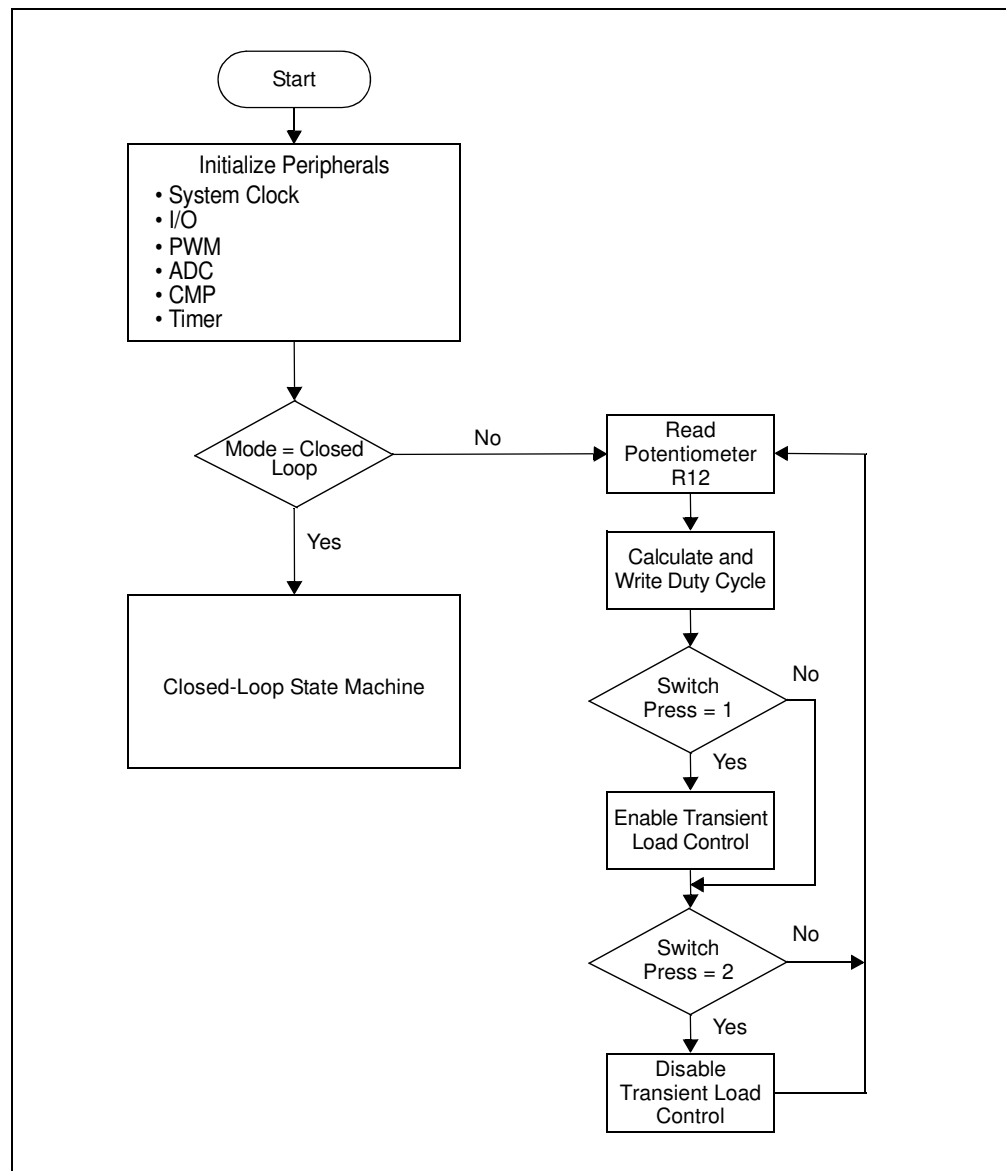
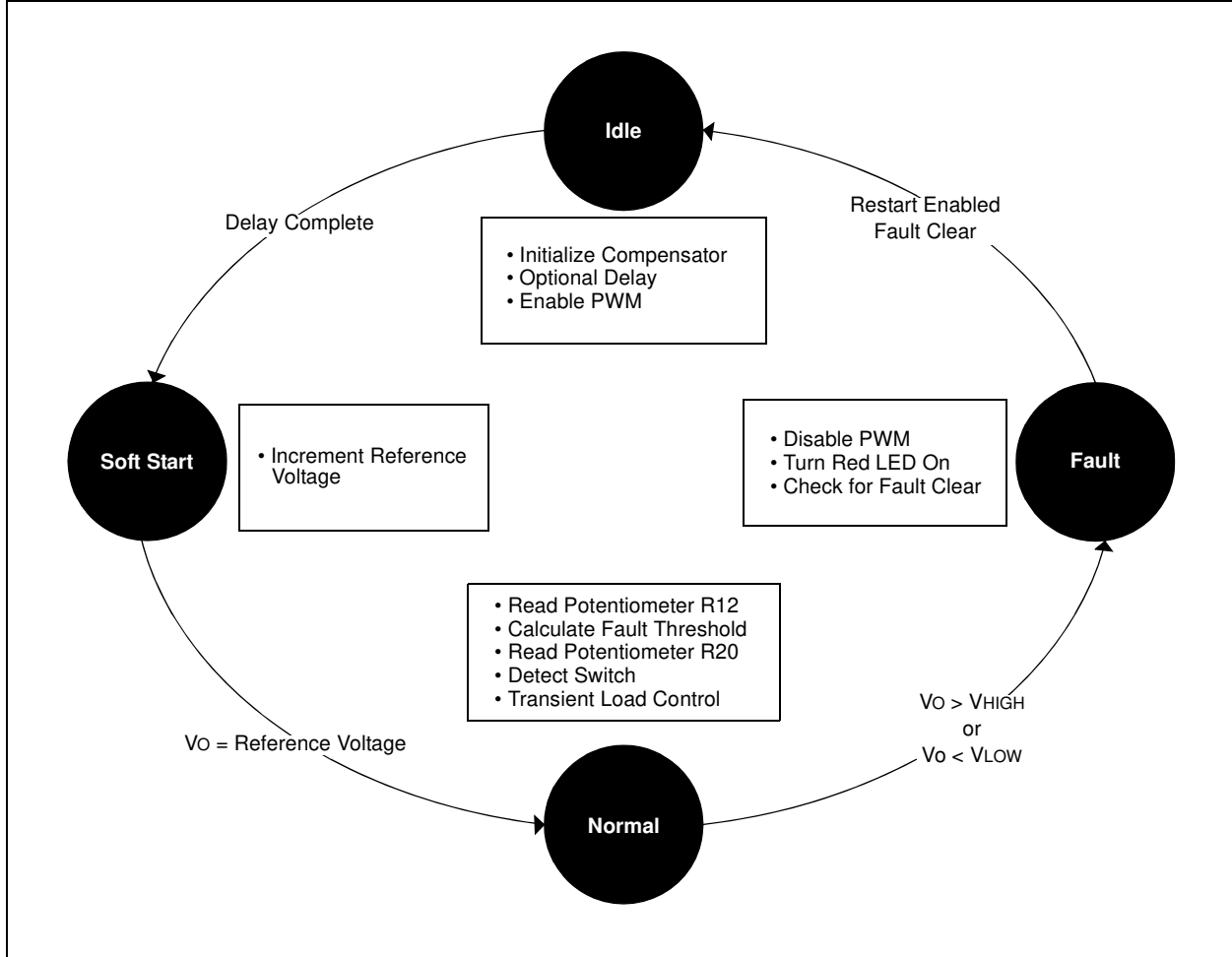

FIGURE 3-8: CLOSED-LOOP STATE MACHINE



3.3 CODE DEMONSTRATION

The software code is based on a state machine, implemented as a foreground process, and interrupt routines are executed in the background. After the initialization phase, the code checks for the operating mode. If it is Open-Loop mode, the output voltage is set to the value decided by potentiometer R12. If it is Closed Loop mode, the state machine routine is executed. There are four states in the state machine, namely Idle, Soft Start, Normal and Fault. The details of each mode are given in the following sections.

3.3.1 System Initialization

When power is applied to the board, the program starts by executing the following system initialization routines:

- Peripherals – The required peripherals (PWM, ADC, Comparators, Timers and GPIO) are configured and enabled.
- Interrupts – Include ADC(s), Timer(s) and comparator(s) interrupts.

3.3.2 Modes

There are two modes of operation: Open-Loop mode and Closed-Loop mode. The Closed-Loop mode is set as the default. In the Open-Loop mode, the output of the PWM is set based on the value set by potentiometer R12. The Open-Loop mode does not execute any Soft Start or Fault state, but executes a load control routine. The transient response of the supply can be monitored by pressing the SW1 switch once. This enables the load control routine, where the transient pulses appear periodically.

In the Closed-Loop mode, the output voltage is set by the control loop based on the reference voltage set. The Closed-Loop mode executes Idle, Soft Start, Normal and Fault states, as shown in [Figure 3-8](#). Load control is part of the Normal state. During load control, if SW1 is pressed once, a transient pulse of duration LDTRANSTIME is applied to MOSFET Q2 with a repeat duration of LDPERIOD. The default settings are set to 1000 μ s (LDTRANSTIME) and 1000 ms (LDPERIOD). Depending on the LOADSW setting to PULLUP or PULLDOWN in the `user.h` file, MOSFET Q2A or Q2B is controlled. A second press of SW1 will turn off the load control feature.

The mode can be changed by setting the variable, `MODE`, to either `OPENLOOPDEMO` or `CLOSELOOPDEMO` in the `user.h` file.

3.3.2.1 IDLE STATE

During the Idle state, the 2P2Z compensator is initialized. The ADC reads the value of potentiometer R12 and sets the reference voltage of the output. The PWM module and the interrupts are enabled in this state. Once all the tasks are completed, the next state is set to Soft Start.

3.3.2.2 SOFT START STATE

In this state, the Soft Start routine ramps up the output voltage in a closed-loop fashion until it is at the programmed output voltage value. This routine ensures that the output does not overshoot the desired voltage caused by a sudden inrush of current.

3.3.2.3 NORMAL STATE

The program reaches the Normal state of operation after Soft Start is complete and stays in this state as long as the operating parameters are within the Fault threshold. The routine checks for a switch press to enable/disable transient pulses. The Fault thresholds are set based on the value of the output voltage. Alternately, the Fault thresholds can be set by potentiometer R20. This helps in changing the thresholds to verify the Fault condition. The ADC interrupt routine runs in the background and occurs at regular intervals of the PWM cycle (decided by the TRIG value). The ADC routine samples the output voltage and runs the 2P2Z controller.

The 2-Pole, 2-Zero (2P2Z) controller, implemented in software, is the digital implementation of the Analog Type II controller. This filter maintains regulation of the output voltage and ensures stability during different line/load conditions. This controller requires three feedback errors multiplied by their associated coefficients, plus the two latest controller output values multiplied by their associated coefficients, along the delay line to provide proper compensation of the power converter. The control design is carried out using the DCDT tool which can be installed as an MPLAB® X plug-in. The DCDT supports different types of filters, such as 2P2Z, 3P3Z, PID, etc. The bode plots of the system plant, compensator and overall system can be viewed with the DCDT tool. The tool automatically converts the design into digital form and generates the coefficients. The coefficient file, `filterx_dcdt.h`, is added as a header file to the project. The filter routine is written in assembly language for faster execution. The routine, `smps_2p2z_dspic_v2.s`, refers to the coefficient file and creates a duty cycle based on the output voltage error.

During operation in Normal mode, the output voltage is checked against Fault thresholds. The Fault checking occurs at a fixed interval, set by Timer2, in the timer interrupt routine. The Fault is enabled or disabled based on the value set for `VLTFLTENABLED` in the `user.h` file. If the output voltage is beyond the thresholds, the state machine changes state to Fault mode.

3.3.2.4 FAULT STATE

The program enters the Fault mode when the output voltage is beyond the Fault thresholds. The PWM module is disabled immediately after entering the Fault state routine. The red LED is lit continuously for visual indication of a Fault. Based on the value set for `RESTARTENABLED` in the `user.h` file, the program enters Latch mode or Restart mode. In Latch mode, the program enters an endless `while` loop and needs a power recycle to start again. In the Restart mode, the routine checks for Faults to clear and enters Idle mode to start all over again.

3.4 OTHER CODE EXAMPLES

There are several code examples available on the Microchip web site. One such code example developed exclusively for this board is mentioned below. Refer to the `Readme` files located in each code example folder for details on what each code example demonstrates. Check the Microchip web site (www.microchip.com/SMPS) for the latest updates to the code examples and for additional code examples.

3.4.1 Dual CAN Communication

The dual CAN communication code is provided to demonstrate basic control of LEDs on the development board. The development board is connected to the CAN/LIN/J2602 PICtail™ (Plus) Daughter Board, which is connected to the CAN host (CAN analyzer). The CAN host communicates with both the CAN (CAN1/CAN2) modules on the development board. Each CAN module has a specific address. The controller on the development board reads the potentiometers R12 and R20, and sends the value to the CAN host periodically, along with the CAN module address. The CAN host sends specific timer values for the CAN1 and CAN2 modules, which are used to blink the LEDs. Thus, changing the potentiometer on the development board will change the LED blink rate based on successful CAN communication.

3.4.2 Other Code Ideas

The development board is versatile and can be programmed to test a number of features. Most of the I/O pins are accessible on one of the several connectors on the board. The connector pins can be used to monitor outputs, connect input signals or provide cross connection between different controller pins. Some of the code ideas are:

- Peak Current Mode Control
- Ramp Generation
- ADC Reference Voltage Control
- Constant Current Source
- Peripheral Pin Select (PPS)
- I²C Communication
- PGA
- PTG/CLC
- PWM Signal as a Fault/Comparator Input
- Fault/Current Limit
- External Period Reset

Appendix A. Board Layout and Schematics

This appendix contains the schematics and board layouts for the dsPIC33EP128GS808 Development Board.

FIGURE A-1: DEVELOPMENT BOARD LAYOUT (TOP)

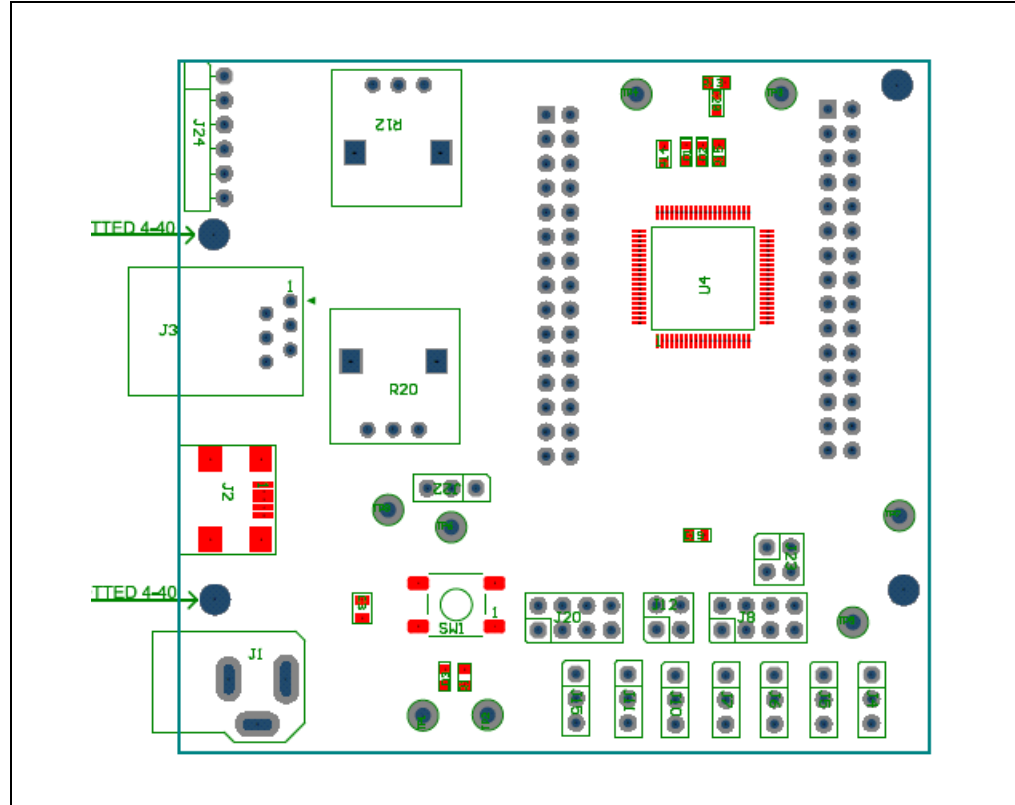

FIGURE A-2: DEVELOPMENT BOARD LAYOUT (BOTTOM)

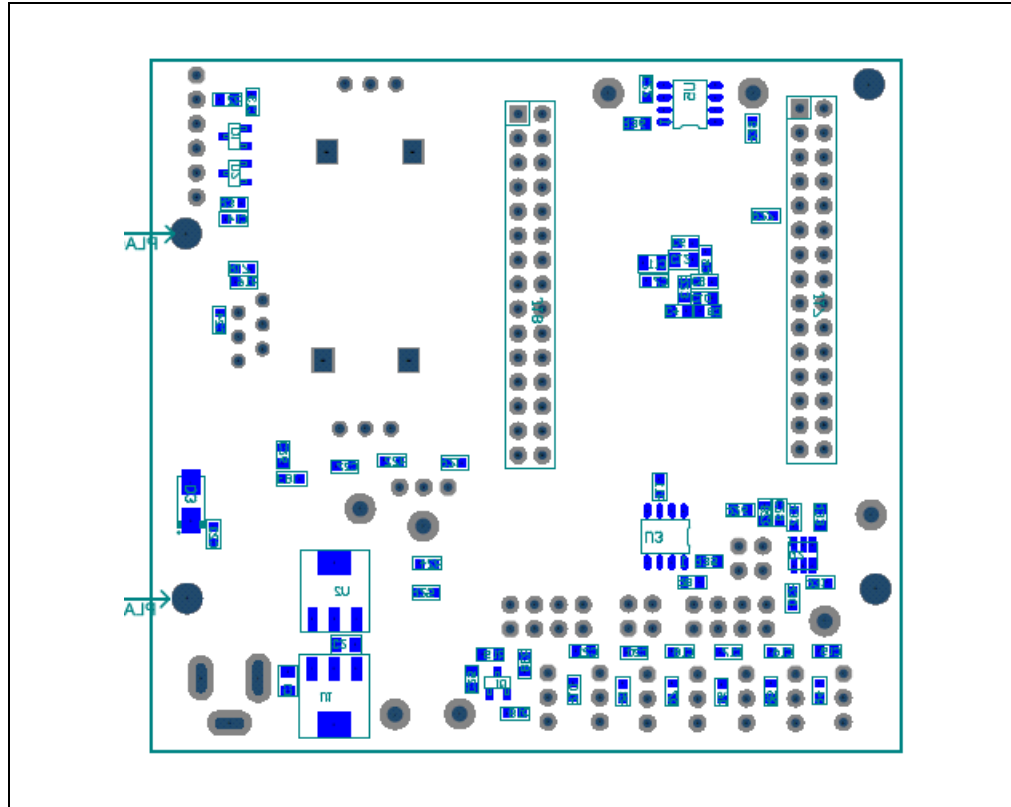

FIGURE A-3: DEVELOPMENT BOARD SCHEMATIC (PAGE 1 OF 2)

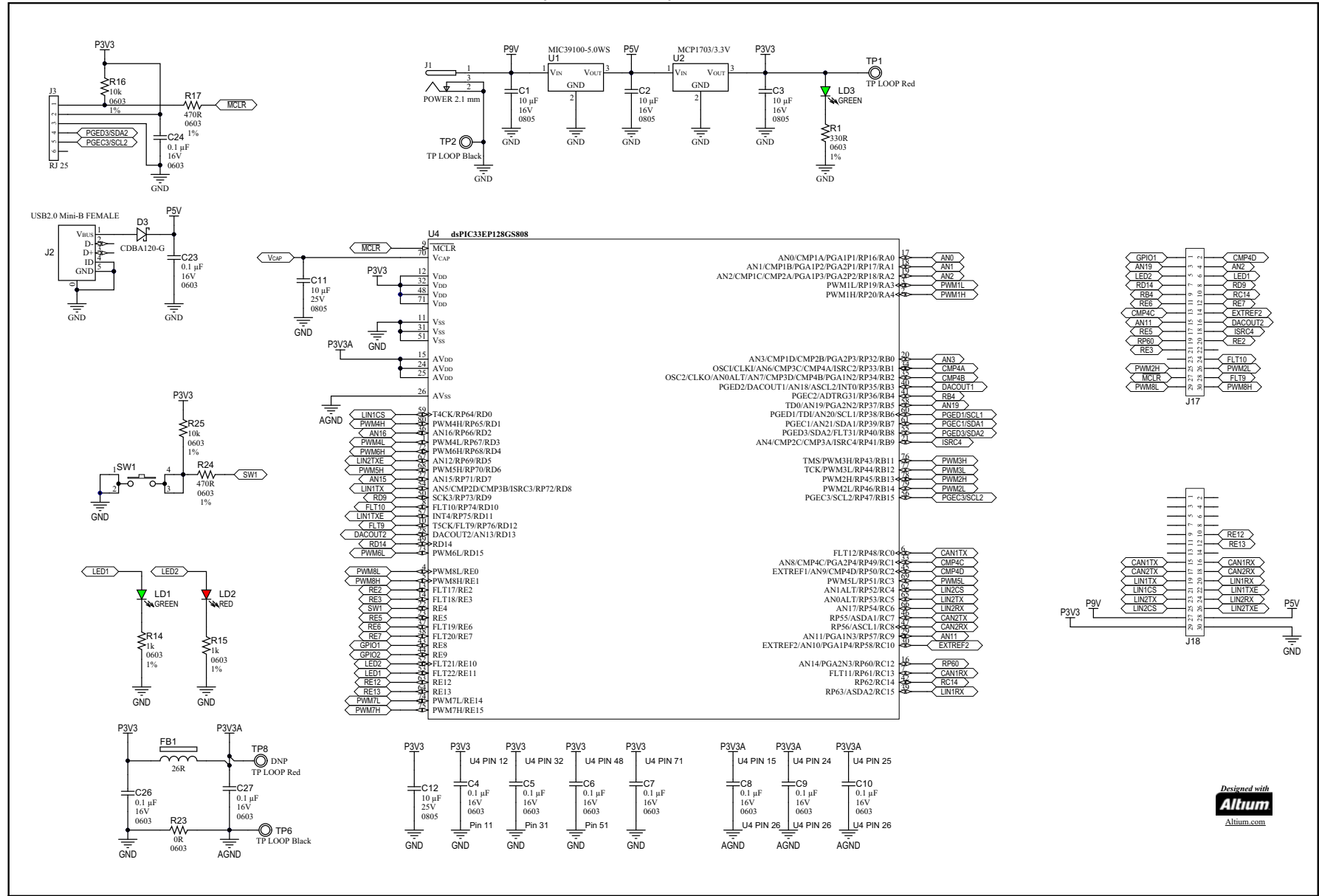
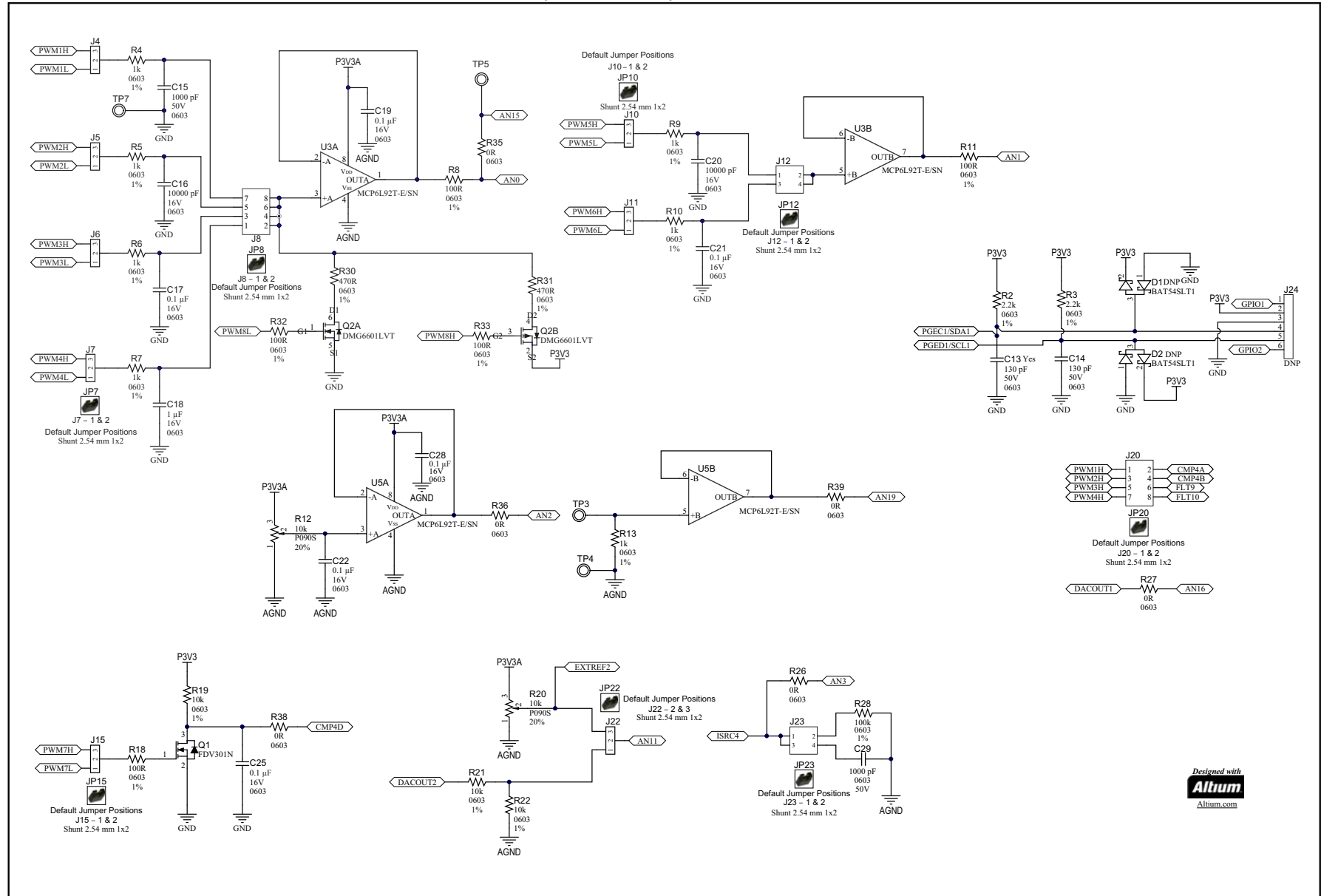

FIGURE A-4: DEVELOPMENT BOARD SCHEMATIC (PAGE 2 OF 2)



NOTES:



MICROCHIP

Worldwide Sales and Service

AMERICAS

Corporate Office
2355 West Chandler Blvd.
Chandler, AZ 85224-6199
Tel: 480-792-7200
Fax: 480-792-7277
Technical Support:
<http://www.microchip.com/support>
Web Address:
www.microchip.com

Atlanta
Duluth, GA
Tel: 678-957-9614
Fax: 678-957-1455

Austin, TX
Tel: 512-257-3370

Boston
Westborough, MA
Tel: 774-760-0087
Fax: 774-760-0088

Chicago
Itasca, IL
Tel: 630-285-0071
Fax: 630-285-0075

Dallas
Addison, TX
Tel: 972-818-7423
Fax: 972-818-2924

Detroit
Novi, MI
Tel: 248-848-4000

Houston, TX
Tel: 281-894-5983

Indianapolis
Noblesville, IN
Tel: 317-773-8323
Fax: 317-773-5453
Tel: 317-536-2380

Los Angeles
Mission Viejo, CA
Tel: 949-462-9523
Fax: 949-462-9608
Tel: 951-273-7800

Raleigh, NC
Tel: 919-844-7510

New York, NY
Tel: 631-435-6000

San Jose, CA
Tel: 408-735-9110
Tel: 408-436-4270

Canada - Toronto
Tel: 905-695-1980
Fax: 905-695-2078

ASIA/PACIFIC

Asia Pacific Office
Suites 3707-14, 37th Floor
Tower 6, The Gateway
Harbour City, Kowloon

Hong Kong
Tel: 852-2943-5100
Fax: 852-2401-3431

Australia - Sydney
Tel: 61-2-9868-6733
Fax: 61-2-9868-6755

China - Beijing
Tel: 86-10-8569-7000
Fax: 86-10-8528-2104

China - Chengdu
Tel: 86-28-8665-5511
Fax: 86-28-8665-7889

China - Chongqing
Tel: 86-23-8980-9588
Fax: 86-23-8980-9500

China - Dongguan
Tel: 86-769-8702-9880

China - Guangzhou
Tel: 86-20-8755-8029

China - Hangzhou
Tel: 86-571-8792-8115
Fax: 86-571-8792-8116

China - Hong Kong SAR
Tel: 852-2943-5100
Fax: 852-2401-3431

China - Nanjing
Tel: 86-25-8473-2460
Fax: 86-25-8473-2470

China - Qingdao
Tel: 86-532-8502-7355
Fax: 86-532-8502-7205

China - Shanghai
Tel: 86-21-3326-8000
Fax: 86-21-3326-8021

China - Shenyang
Tel: 86-24-2334-2829
Fax: 86-24-2334-2393

China - Shenzhen
Tel: 86-755-8864-2200
Fax: 86-755-8203-1760

China - Wuhan
Tel: 86-27-5980-5300
Fax: 86-27-5980-5118

China - Xian
Tel: 86-29-8833-7252
Fax: 86-29-8833-7256

ASIA/PACIFIC

China - Xiamen
Tel: 86-592-2388138
Fax: 86-592-2388130

China - Zhuhai
Tel: 86-756-3210040
Fax: 86-756-3210049

India - Bangalore
Tel: 91-80-3090-4444
Fax: 91-80-3090-4123

India - New Delhi
Tel: 91-11-4160-8631
Fax: 91-11-4160-8632

India - Pune
Tel: 91-20-3019-1500

Japan - Osaka
Tel: 81-6-6152-7160
Fax: 81-6-6152-9310

Japan - Tokyo
Tel: 81-3-6880-3770
Fax: 81-3-6880-3771

Korea - Daegu
Tel: 82-53-744-4301
Fax: 82-53-744-4302

Korea - Seoul
Tel: 82-2-554-7200
Fax: 82-2-558-5932 or
82-2-558-5934

Malaysia - Kuala Lumpur
Tel: 60-3-6201-9857
Fax: 60-3-6201-9859

Malaysia - Penang
Tel: 60-4-227-8870
Fax: 60-4-227-4068

Philippines - Manila
Tel: 63-2-634-9065
Fax: 63-2-634-9069

Singapore
Tel: 65-6334-8870
Fax: 65-6334-8850

Taiwan - Hsin Chu
Tel: 886-3-5778-366
Fax: 886-3-5770-955

Taiwan - Kaohsiung
Tel: 886-7-213-7830

Taiwan - Taipei
Tel: 886-2-2508-8600
Fax: 886-2-2508-0102

Thailand - Bangkok
Tel: 66-2-694-1351
Fax: 66-2-694-1350

EUROPE

Austria - Wels
Tel: 43-7242-2244-39
Fax: 43-7242-2244-393

Denmark - Copenhagen
Tel: 45-4450-2828
Fax: 45-4485-2829

Finland - Espoo
Tel: 358-9-4520-820

France - Paris
Tel: 33-1-69-53-63-20
Fax: 33-1-69-30-90-79

France - Saint Cloud
Tel: 33-1-30-60-70-00

Germany - Garching
Tel: 49-8931-9700

Germany - Haan
Tel: 49-2129-3766400

Germany - Heilbronn
Tel: 49-7131-67-3636

Germany - Karlsruhe
Tel: 49-721-625370

Germany - Munich
Tel: 49-89-627-144-0
Fax: 49-89-627-144-44

Germany - Rosenheim
Tel: 49-8031-354-560

Israel - Ra'anana
Tel: 972-9-744-7705

Italy - Milan
Tel: 39-0331-742611
Fax: 39-0331-466781

Italy - Padova
Tel: 39-049-7625286

Netherlands - Drunen
Tel: 31-416-690399
Fax: 31-416-690340

Norway - Trondheim
Tel: 47-7289-7561

Poland - Warsaw
Tel: 48-22-3325737

Romania - Bucharest
Tel: 40-21-407-87-50

Spain - Madrid
Tel: 34-91-708-08-90
Fax: 34-91-708-08-91

Sweden - Gothenberg
Tel: 46-31-704-60-40

Sweden - Stockholm
Tel: 46-8-5090-4654

UK - Wokingham
Tel: 44-118-921-5800
Fax: 44-118-921-5820