

KSDB SERIES

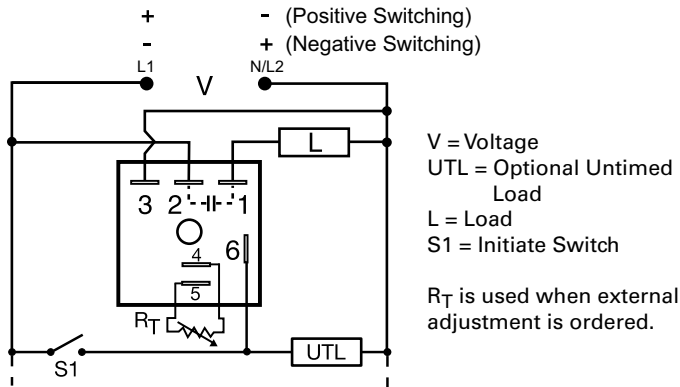

Wiring Diagram



Description

The KSDB Series is designed for general purpose commercial and industrial applications where a small, cost effective, reliable solid-state timer is required. The factory calibration for fixed time delays is within 5% of the target time delay. The repeat accuracy, under stable conditions, is 0.5% of the selected time delay. This series is designed for popular AC and DC voltages. Time delays of 0.1 seconds to 1000 minutes are available in 6 ranges. The output is rated 1A steady and 10A inrush. The modules are totally solid state and encapsulated to protect the electronic circuitry.

Operation (Delay-on-Break)

Input voltage must be applied before and during timing. Upon closure of the initiate switch, the output energizes. The time delay begins when the initiate switch is opened. The output remains energized during timing. At the end of the time delay, the output de-energizes. The output energizes if the initiate switch is closed when input voltage is applied.

Reset: Reclosing the initiate switch during timing resets the time delay. Loss of input voltage resets the time delay and output.

Features & Benefits

FEATURES	BENEFITS
Microcontroller based	Repeat accuracy +/- 0.5%, Factory calibration +/- 5%
1A Steady, 10A inrush solid-state output	Provides 100 million operations in typical conditions.
Totally solid state and encapsulated	No moving parts to arc and wear out over time and encapsulated to protect against shock, vibration, and humidity
Compact, low cost design	Allows flexibility for OEM applications

Ordering Information

MODEL	INPUT VOLTAGE	ADJUSTMENT	TIME DELAY	SWITCHING MODE	MODEL	INPUT VOLTAGE	ADJUSTMENT	TIME DELAY	SWITCHING MODE
KSDB1110MP	12VDC	Fixed	10m	Positive	KSDB314SP	24VDC	Fixed	4s	Positive
KSDB1115SP	12VDC	Fixed	15s	Positive	KSDB315SP	24VDC	Fixed	5s	Positive
KSDB1120SP	12VDC	Fixed	20s	Positive	KSDB324N	24VDC	External	1 - 100m	Negative
KSDB113MP	12VDC	Fixed	3m	Positive	KSDB330N	24VDC	Onboard	0.1 - 10s	Negative
KSDB113SP	12VDC	Fixed	3s	Positive	KSDB4120M	120VAC	Fixed	20m	n/a
KSDB120P	12VDC	External	0.1 - 10s	Positive	KSDB4160S	120VAC	Fixed	60s	n/a
KSDB134P	12VDC	Onboard	1 - 100m	Positive	KSDB4190M	120VAC	Fixed	90m	n/a
KSDB2115S	24VAC	Fixed	15s	n/a	KSDB431	120VAC	Onboard	1 - 100s	n/a
KSDB220	24VAC	External	0.1 - 10s	n/a	KSDB61150S	230VAC	Fixed	150s	n/a
KSDB231	24VAC	Onboard	1 - 100s	n/a	KSDB631	230VAC	Onboard	1 - 100s	n/a

If you don't find the part you need, call us for a custom product 800-843-8848

KSDB SERIES

Accessories



P1004-95, P1004-95-X Versa-Pot
Panel mountable, industrial potentiometer recommended for remote time delay adjustment.



P1023-6 Mounting bracket
The 90° orientation of mounting slots makes installation/removal of modules quick and easy.



P0700-7 Versa-Knob
Designed for 0.25 in. (6.35 mm) shaft of Versa-Pot. Semi-gloss industrial black finish.



P1015-64 (AWG 14/16), P1015-14 (AWG 18/22) Female Quick Connect
These 0.25 in. (6.35 mm) female terminals are constructed with an insulator barrel to provide strain relief.



P1015-18 Quick Connect to Screw Adapter
Screw adapter terminal designed for use with all modules with 0.25 in. (6.35 mm) male quick connect terminals.



C103PM (AL) DIN Rail
35 mm aluminum DIN rail available in a 36 in. (91.4 cm) length.



P1023-20 DIN Rail Adapter
Allows module to be mounted on a 35 mm DIN type rail with two #10 screws.

External Resistance vs. Time Delay

In Secs. or Mins.

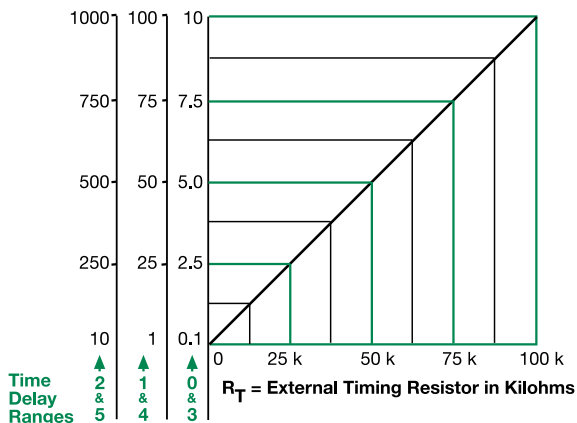

This chart applies to externally adjustable part numbers.
The time delay is adjustable over the time delay range selected by varying the resistance across the R_T terminals; as the resistance increases the time delay increases.

When selecting an external R_T , add the tolerances of the timer and the R_T for the full time range adjustment.

Examples: 1 to 50 S adjustable time delay, select time delay range 1 and a 50 K ohm R_T . For 1 to 100 S use a 100 K ohm R_T .

Specifications

Time Delay Range	0.1s - 1000m in 6 adjustable ranges or fixed
Repeat Accuracy Tolerance (Factory Calibration)	±0.5 % or 20ms, whichever is greater
Reset Time	≤ ±5%
Initiate Time	≤ 150ms
Time Delay vs Temp. & Voltage	≤ 20ms
Input Voltage	≤ ±10%
Tolerance	12, 24, or 120VDC; 24, 120, or 230VAC
Power Consumption	±20%
AC Line Frequency/DC Ripple	AC ≤ 2VA; DC ≤ 2W
Output Type	50/60 Hz / ≤ 10 %
Form	Solid state
Maximum Load Current	NO, closed before & during timing
OFF State Leakage Current	1A steady state, 10A inrush at 60°C
Voltage Drop	AC ≅ 5mA @ 230VAC; DC ≅ 1mA
DC Operation	AC ≅ 2.5V @ 1A; DC ≅ 1V @ 1A
Protection	Positive or negative switching
Circuitry	Encapsulated
Dielectric Breakdown	≥ 2000V RMS terminals to mounting surface
Insulation Resistance	≥ 100 MΩ
Polarity	DC units are reverse polarity protected
Mechanical Mounting Dimensions	Surface mount with one #10 (M5 x 0.8) screw H 50.8 mm (2.0"); W 50.8 mm (2.0"); D 30.7 mm (1.21")
Termination	0.25 in. (6.35 mm) male quick connect terminals
Environmental Operating/Storage Temperature	-40° to 60°C / -40° to 80°C
Humidity	95% relative, non-condensing
Weight	≅ 2.4 oz (68 g)

Function Diagram

