

| PART NUMBER | REVISION | DESCRIPTION                     | FEED TYPE |
|-------------|----------|---------------------------------|-----------|
| 2150522-2   | C        | FINE CRIMP HEIGHT ADJUST        | PNEUMATIC |
| 7-2150522-2 | C        | PNEUMATIC AND CRIMP TOOLING KIT | PNEUMATIC |
| 7-2150522-7 | A        | CRIMP TOOLING KIT               | -         |

ATLANTIC VERSION TERMINATOR INTERFACE ADAPTER

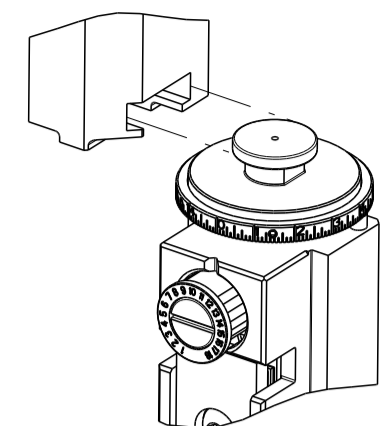

| APPLICATOR DATA                |                |      |
|--------------------------------|----------------|------|
| CRIMP                          | SIZE           | TYPE |
| WIRE                           | 2.54 mm [.100] | F    |
| INSUL                          | 4.57 mm [.180] | O    |
| APPL INSTRUCTIONS<br>408-35043 |                |      |

|                                                  |             |                              |             |
|--------------------------------------------------|-------------|------------------------------|-------------|
| TERMINAL DATA: TE TERMINAL - CRIMP SPECIFICATION |             |                              |             |
| TERMINAL NAME: TAB, FASTIN-FASTON, .187 SERIES   |             |                              |             |
| WIRE STRIP LENGTH                                |             | INSULATION DIAMETER RANGE    |             |
| 4.20-5.10 mm [.165-.201 IN]                      |             | ∅2.79-3.81 mm [.110-.150 IN] |             |
| TERMINAL APPLICATION SPECIFICATION               | NONE        |                              |             |
| TERMINALS APPLIED                                |             |                              |             |
| TE TERMINAL                                      | TE TERMINAL | TE TERMINAL                  | TE TERMINAL |
| 1742800-1                                        |             |                              |             |

| WIRE SIZE | CRIMP HEIGHT mm [INCH]        | CRIMP HEIGHT REFERENCE SETTING |
|-----------|-------------------------------|--------------------------------|
| 14 AWG    | 2.24 +/- 0.05 [.088 +/- .002] | 3.2                            |
| 16 AWG    | 1.98 +/- 0.05 [.078 +/- .002] | 6.2                            |
| 18 AWG    | 1.83 +/- 0.05 [.072 +/- .002] | 7.8                            |

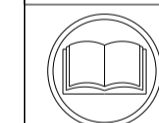

- 1 RECOMMENDED SPARE PARTS
- 2 REFER TO SUPPLIED INSTRUCTION SHEET FOR CLEANING, LUBRICATION AND STORAGE OF APPLICATOR.
- 3 APPLY PART NUMBER 2-23419-6 LOCTITE TO THREADS OF ITEM 242. APPLY PART NUMBER 1-23419-5 LOCTITE TO THREADS OF ITEM 180.
- 4 CRIMP HEIGHT REFERENCE SETTING WAS THE SETTING USED WHEN THE APPLICATOR WAS QUALIFIED AT THE FACTORY. ADJUSTMENT MAY BE NECESSARY WHEN RUNNING APPLICATOR IN THE FIELD.
- 5 TERMINAL PITCH NOT COMPATABLE WITH MECHANICAL FEED.
- 6. UNLESS SPECIFIED OTHERWISE TORQUE VALUES SHALL BE USED PER DOCUMENT, 101-35000.

**\*WARNING**  
ON INSTALLATION, SET WIRE DISC TO CRIMP HEIGHT REFERENCE SETTING FOR LARGEST WIRE SIZE. CRIMP HEIGHT REFERENCE SETTINGS GREATER THAN THE VALUE SHOWN MAY CAUSE DAMAGE TO THE CRIMP TOOLING. REFER TO THE INSTRUCTION SHEET FOR PROPER SETUP AND ADJUSTMENTS.

| LOC | DIST | REVISIONS |     |               |           |     |      |
|-----|------|-----------|-----|---------------|-----------|-----|------|
| A   | 66   | P         | LTN | DESCRIPTION   | DATE      | DWN | APVD |
|     |      | A         |     | RELEASED      | 19FEB2015 | BW  | GB   |
|     |      | B         |     | ECR-19-009504 | 18JUN2019 | TB  | TE   |
|     |      | C         |     | ECR-19-011869 | 27JUL2019 | TB  | TE   |

|   |     |     |             |                                     |             |         |
|---|-----|-----|-------------|-------------------------------------|-------------|---------|
| - | 1   | 1   | 2119641-1   | FEED CAM, AIR FEED                  | 248         |         |
| - | 1   | 1   | 2119082-3   | CAM, SNAIL, INSULATION ADJUSTMENT   | 244         |         |
| - | 1   | 1   | 2079764-1   | WASHER, WAVE SPRING, CREST-TO-CREST | 243         |         |
| - | 1   | 1   | 2119083-1   | RETAINER, INSULATION DIAL           | 242         |         |
| - | 1   | 1   | 2844940-4   | AIR FEED MODULE                     | 238         |         |
| - | 1   | 1   | 1-18028-0   | WASHER, FLAT, REG M8                | 192         |         |
| - | 1   | 1   | 1-1752354-0 | STANDOFF, HOLD-DOWN                 | 180         |         |
| - | 1   | 1   | 6-993111-6  | PIN, SLOTTED SPRING 3.0 X 14.0      | 177         |         |
| - | 1   | 1   | 8-22280-7   | SPRING, COMPRESSION                 | 176         |         |
| - | 1   | 1   | 1752353-2   | GUIDE PIN, HOLDDOWN                 | 175         |         |
| - | 1   | 1   | 1901680-2   | GUIDE PIN, HOLDDOWN                 | 174         |         |
| - | REF | REF | 994970-2    | COUNTER, MAGNETIC                   | 164         |         |
| - | 2   | 2   | 18024-1     | SCR, BTN SKT HD CAP (M3 X 6.0)      | 144         |         |
| - | 1   | 1   | 1-1976053-3 | LOCATER BLOCK, TERMINAL             | 143         |         |
| - | 1   | 1   | 455888-4    | SPACER, CRIMPER                     | 82          |         |
| - | 1   | 1   | 2119791-5   | DEPRESSOR, WIRE                     | 73          |         |
| - | 1   | 1   | 1803607-4   | DOCUMENTATION PACKAGE               | 71          |         |
| - | 2   | 2   | 2-18032-2   | SCR, SET, FLT PNT, M3 X 10.0        | 70          |         |
| - | 1   | 1   | 2119943-1   | WASHER, SPACER                      | 69          |         |
| - | 1   | 1   | 2119740-1   | TAG, IDENTIFICATION                 | 67          |         |
| - | 2   | 2   | 2168078-1   | SCREW, DRIVE, RH, RoHS, 2 x .188    | 66          |         |
| - | 1   | 1   | 1901681-8   | HOLDDOWN, TERMINAL                  | 65          |         |
| - | 1   | 1   | 2168083-2   | SCR, SKT HD CAP, RoHS, M4 X 8.0     | 60          |         |
| - | 1   | 1   | 5-18022-5   | SCR, HEX HD CAP, M4 X 6.0           | 59          |         |
| - | 4   | 4   | 2168400-4   | SHCS, LOW HEAD, RoHS, M4 X 8        | 57          |         |
| - | 2   | 2   | 2168083-9   | SCR, SKT HD CAP, RoHS, M4 X 20      | 56          |         |
| - | 2   | 2   | 5018030-1   | NUT, HEX, REG, RoHS, M3             | 54          |         |
| - | 2   | 2   | 986965-8    | NUT, LOCK, HEX, TORQUE (M4)         | 53          |         |
| - | 1   | 1   | 1-5018030-0 | NUT, HEX, REG, RoHS, M3.5           | 52          |         |
| - | 1   | 1   | 2063961-1   | FEED FINGER                         | 51          |         |
| - | 1   | 1   | 18023-9     | SCR, SKT HD CAP M4 X 6.0            | 49          |         |
| - | 1   | 1   | 2119655-5   | APPLICATOR BASIC ASSEMBLY, EF       | 46          |         |
| - | 1   | 1   | 1803517-1   | RAM ASSEMBLY, EF ATLANTIC           | 44          |         |
| - | 1   | 1   | 1803602-1   | SCR, BHSC, RoHS (M8 X 25)           | 41          |         |
| - | 8   | 8   | 1-18028-2   | WASHER, FLAT, REG M4                | 33          |         |
| - | 2   | 2   | 2168083-9   | SCR, SKT HD CAP, RoHS, M4 X 20      | 31          |         |
| - | 2   | 2   | 2168083-2   | SCR, SKT HD CAP, RoHS, M4 X 8.0     | 29          |         |
| - | 1   | 1   | 240639-1    | STRIPPER (MACHINING)                | 27          |         |
| - | 2   | 2   | 1-2168083-5 | SCR, SKT HD CAP, RoHS, M4 X 30      | 25          |         |
| - | 1   | 1   | 1752371-5   | PLATE, STRIP GUIDE                  | 24          |         |
| - | 2   | 2   | 2-22281-3   | SPRING, COMPRESSION                 | 22          |         |
| - | 1   | 1   | 1803292-4   | DRAG                                | 20          |         |
| - | 1   | 1   | 1-1901696-9 | STRIP GUIDE, REAR                   | 19          |         |
| - | 1   | 1   | 1-1901695-9 | STRIP GUIDE, FRONT                  | 18          |         |
| - | 4   | 4   | 1-2079383-1 | SCR, BHSC, RoHS (M6 X 12)           | 17          |         |
| - | 1   | 1   | 240641-4    | SPACER                              | 16          |         |
| - | 1   | 1   | 1752360-1   | SPACER, HOLD-DOWN                   | 13          |         |
| - | 1   | 1   | 240644-1    | PLATE, REAR SHEAR                   | 11          |         |
| - | 2   | 2   | 1-240645-4  | SPACER, SHEAR PLATE                 | 10          |         |
| - | 1   | 1   | 240642-4    | PLATE, FRONT SHEAR                  | 9           |         |
| 1 | 2   | 1   | 6-1633383-6 | ANVIL, COMBINATION                  | 8           |         |
| - | 1   | 1   | 9-240651-1  | BLADE, SLUG                         | 7           |         |
| - | -   | -   | -           | -                                   | 6           |         |
| - | 1   | 1   | 5-240641-5  | SPACER                              | 5           |         |
| - | 1   | 1   | 238011-2    | BLOCK, CRIMPER SPACER               | 4           |         |
| 1 | 2   | 1   | 6-2119784-0 | CRIMPER, INSULATION O PREMIUM       | 3           |         |
| - | 1   | 1   | 455888-3    | SPACER, CRIMPER                     | 2           |         |
| 1 | 2   | 1   | 456407-4    | CRIMPER, WIRE PREMIUM               | 1           |         |
| - | 77  | 72  | -2          | PART NO                             | DESCRIPTION | ITEM NO |

ATLANTIC VERSION  
Shown on sheets 1 of 4 & 2 of 4  
(Pacific version shown on sheets 3 of 4 & 4 of 4)

|             |  |                                        |  |                         |  |                                        |  |                          |  |                           |  |
|-------------|--|----------------------------------------|--|-------------------------|--|----------------------------------------|--|--------------------------|--|---------------------------|--|
| DIMENSIONS: |  | TOLERANCES UNLESS OTHERWISE SPECIFIED: |  | DWN B. WEAVER 23DEC2014 |  | CHK G. BAILEY 23DEC2014                |  | APVD G. BAILEY 23DEC2014 |  | NAME                      |  |
| mm          |  | 0 PLC ±                                |  | G. BAILEY 23DEC2014     |  | NAME                                   |  | PRODUCT SPEC             |  | Ocean End Feed Applicator |  |
|             |  | 1 PLC ±                                |  | APPLICATION SPEC        |  | SIZE                                   |  | CAGE CODE                |  | DRAWING NO                |  |
|             |  | 2 PLC ±                                |  | WEIGHT                  |  | A1                                     |  | 00779                    |  | ©=2150522                 |  |
|             |  | 3 PLC ±                                |  | MATERIAL                |  | Customer Accessible Production Drawing |  | SCALE                    |  | 1:1 SHEET 1 of 4 REV C    |  |
|             |  | 4 PLC ±                                |  | FINISH                  |  |                                        |  |                          |  |                           |  |
|             |  | ANGLES                                 |  |                         |  |                                        |  |                          |  |                           |  |
|             |  | FINISH                                 |  |                         |  |                                        |  |                          |  |                           |  |

| LOC | DIST | REVISIONS   |      |     |      |
|-----|------|-------------|------|-----|------|
| P   | LTN  | DESCRIPTION | DATE | OWN | APVD |
| A   | 66   | SEE SHEET 1 | -    | -   | -    |

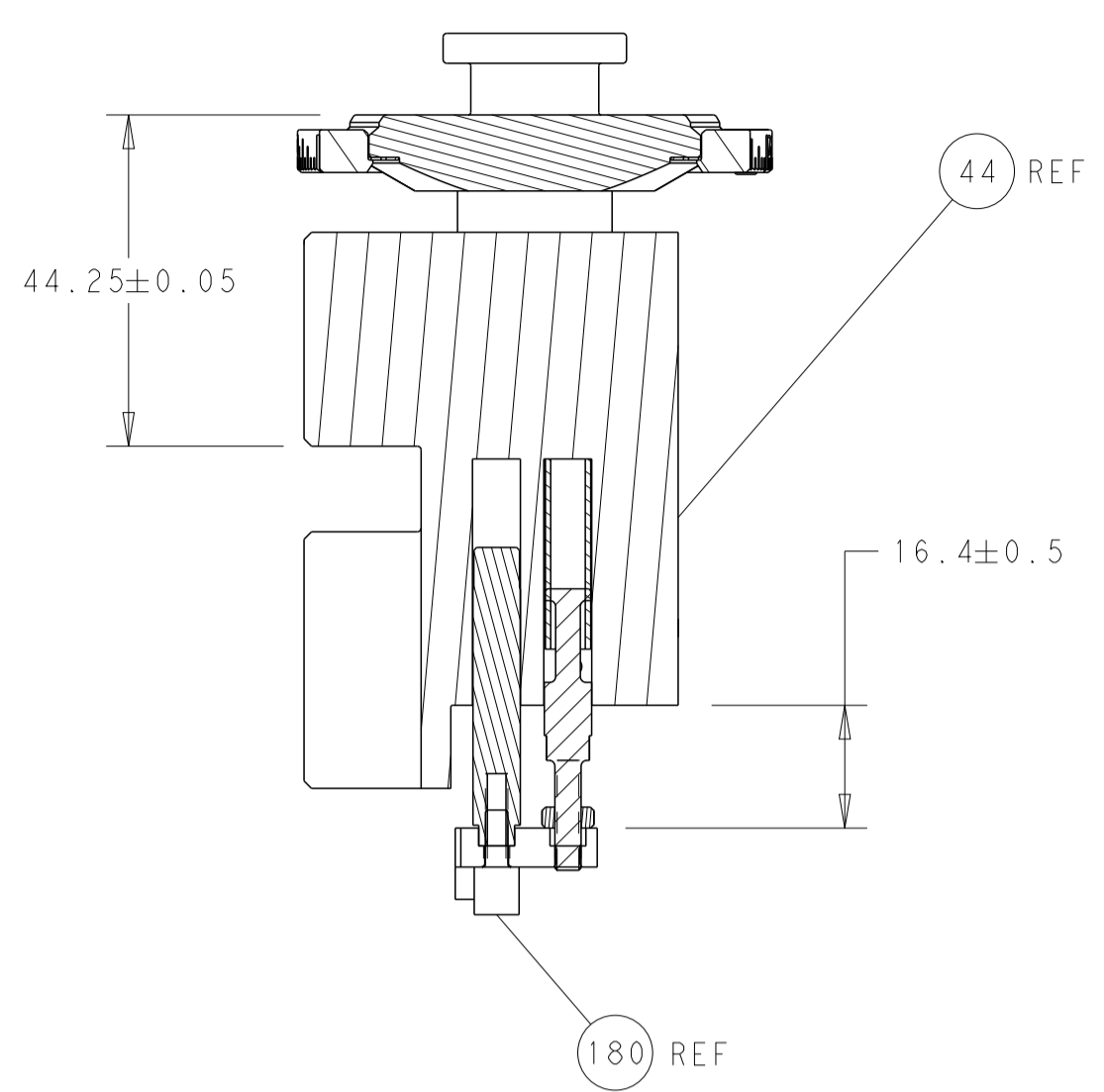

RAM AND HOLDDOWN SET-UP

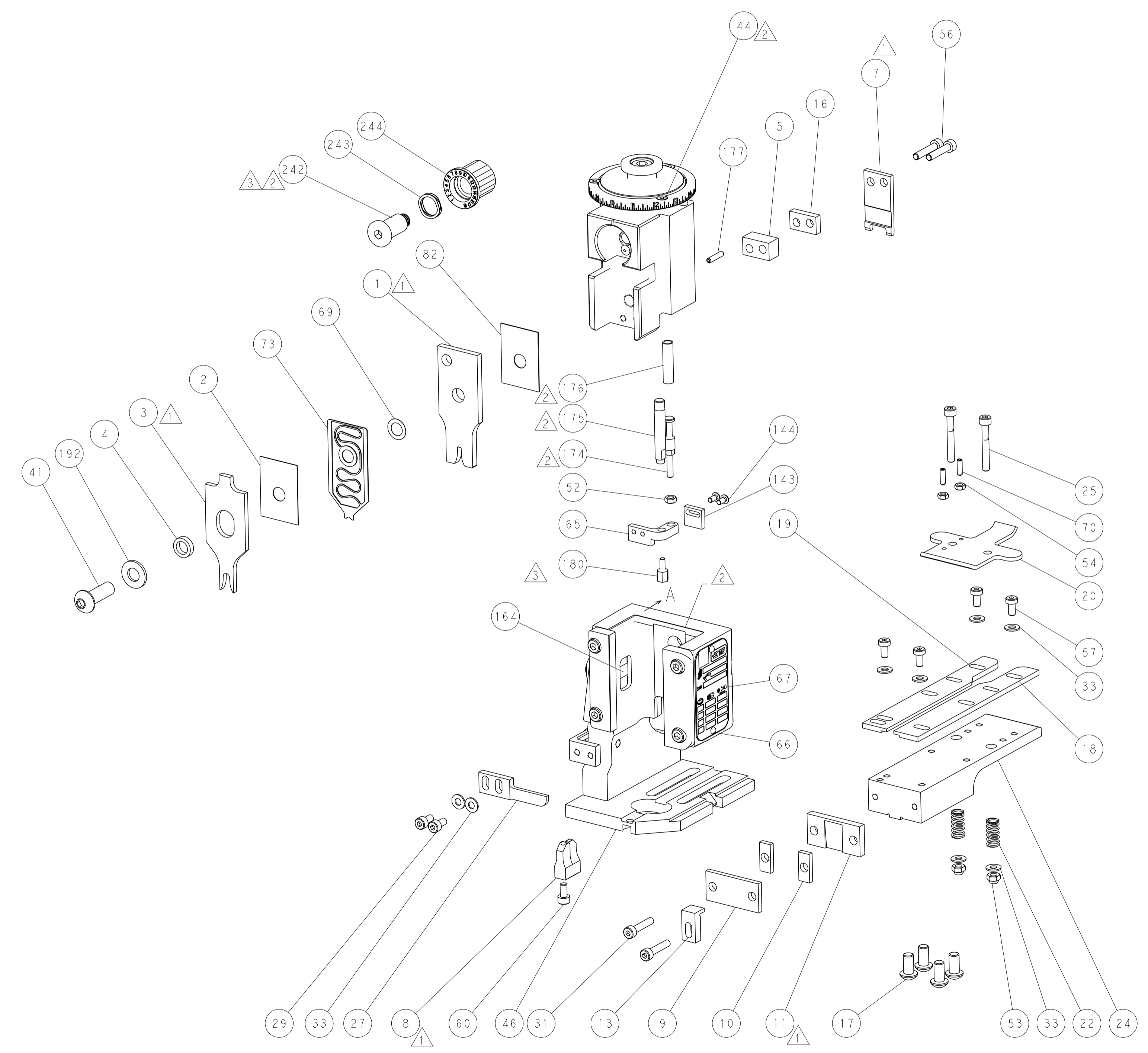

FEED TYPE

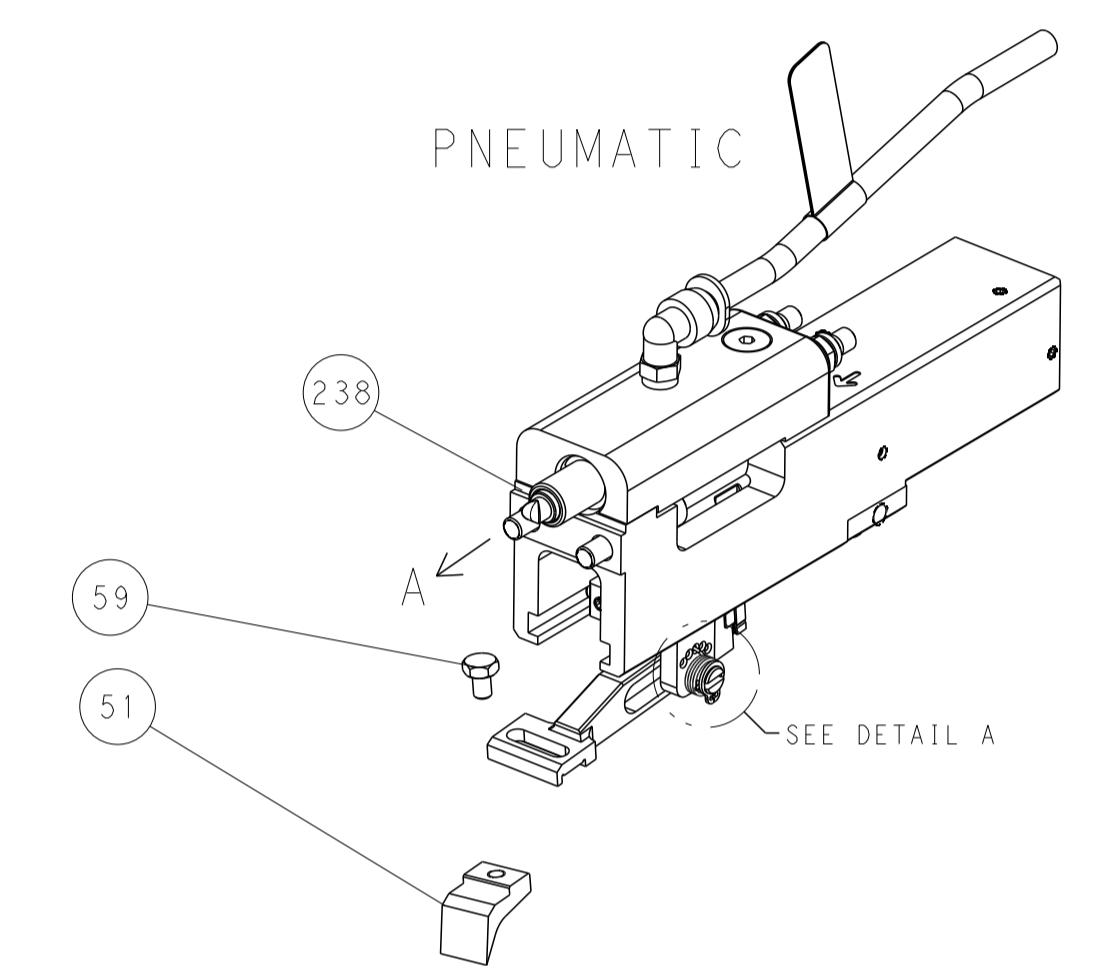

PNEUMATIC

FEED SPRING SETTING POSITION

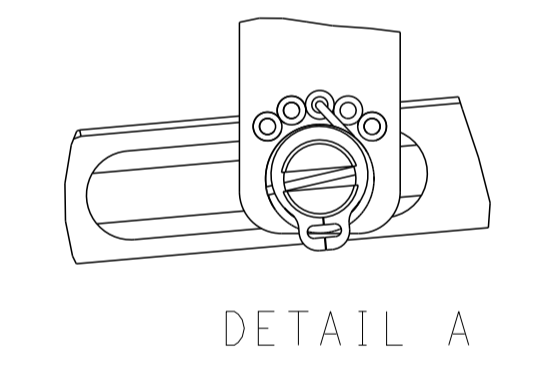

DETAIL A

CAM POSITION

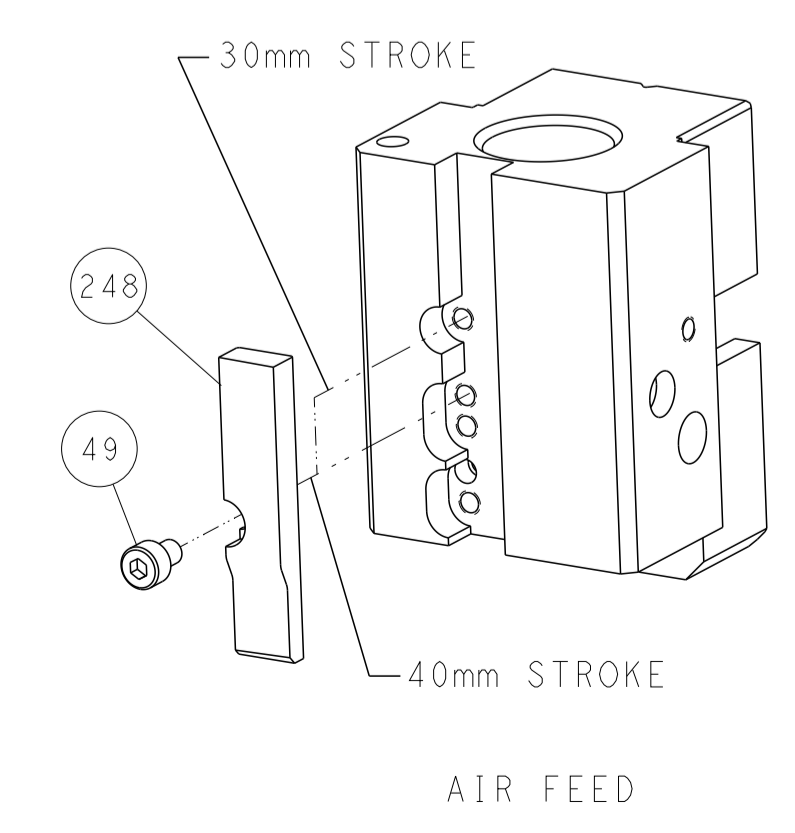

AIR FEED

ATLANTIC VERSION  
 Shown on sheets 1 of 4 & 2 of 4  
 (Pacific version shown on sheets 3 of 4 & 4 of 4)

|             |         |                                        |         |                                        |         |                              |                           |
|-------------|---------|----------------------------------------|---------|----------------------------------------|---------|------------------------------|---------------------------|
| DIMENSIONS: |         | TOLERANCES UNLESS OTHERWISE SPECIFIED: |         | DWG: B. WEAVER 23DEC2014               |         | TE Connectivity              |                           |
| mm          | 0 PLC ± | 1 PLC ±                                | 2 PLC ± | 3 PLC ±                                | 4 PLC ± | 5 PLC ±                      | Harrisburg, PA 17105-3608 |
| MATERIAL:   |         | FINISH:                                |         | CHK: G. BAILEY 23DEC2014               |         | NAME: Ocean End Feed Applier |                           |
|             |         |                                        |         | APVD: G. BAILEY 23DEC2014              |         | RESTRICTED TO:               |                           |
|             |         |                                        |         | PRODUCT SPEC:                          |         | SIZE: A1                     |                           |
|             |         |                                        |         | APPLICATION SPEC:                      |         | CAGE CODE: 00779             |                           |
|             |         |                                        |         | WEIGHT:                                |         | DRAWING NO: C=2150522        |                           |
|             |         |                                        |         | Customer Accessible Production Drawing |         | SCALE: 1:1                   |                           |
|             |         |                                        |         | SHEET: 2 of 4                          |         | REV: C                       |                           |

| 8                                                                    | 7        | 6                        | 5         | 4    | 3 | 2 | 1 |
|----------------------------------------------------------------------|----------|--------------------------|-----------|------|---|---|---|
| THIS DRAWING IS UNPUBLISHED.                                         |          | RELEASED FOR PUBLICATION |           | 2014 |   |   |   |
| COPYRIGHT 2014 BY TYCO ELECTRONICS CORPORATION. ALL RIGHTS RESERVED. |          |                          |           |      |   |   |   |
| PART NUMBER                                                          | REVISION | DESCRIPTION              | FEED TYPE |      |   |   |   |
| 2-2150522-2                                                          | C        | FINE CRIMP HEIGHT ADJUST | PNEUMATIC |      |   |   |   |
| 7-2150522-7                                                          | A        | CRIMP TOOLING KIT        | -         |      |   |   |   |

PACIFIC VERSION TERMINATOR  
INTERFACE ADAPTER

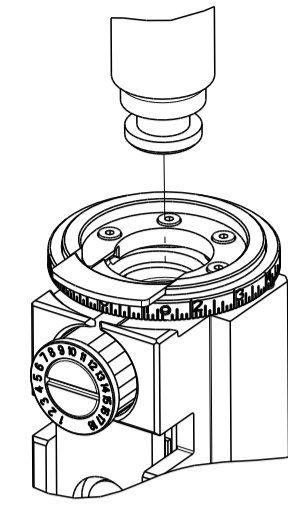

| APPLICATOR DATA                |                |      |
|--------------------------------|----------------|------|
| CRIMP                          | SIZE           | TYPE |
| WIRE                           | 2.54 mm [.100] | F    |
| INSUL                          | 4.57 mm [.180] | O    |
| APPL INSTRUCTIONS<br>408-35043 |                |      |

|                                                  |             |                              |             |
|--------------------------------------------------|-------------|------------------------------|-------------|
| TERMINAL DATA: TE TERMINAL - CRIMP SPECIFICATION |             |                              |             |
| TERMINAL NAME: TAB, FASTIN-FASTON, .187 SERIES   |             |                              |             |
| WIRE STRIP LENGTH                                |             | INSULATION DIAMETER RANGE    |             |
| 4.20-5.10 mm [.165-.201 IN]                      |             | Ø2.79-3.81 mm [.110-.150 IN] |             |
| TERMINAL APPLICATION SPECIFICATION               | NONE        |                              |             |
| TERMINALS APPLIED                                |             |                              |             |
| TE TERMINAL                                      | TE TERMINAL | TE TERMINAL                  | TE TERMINAL |
| 1742800-1                                        |             |                              |             |

| WIRE SIZE | CRIMP HEIGHT mm [INCH]        | CRIMP HEIGHT REFERENCE SETTING |
|-----------|-------------------------------|--------------------------------|
| 14 AWG    | 2.24 +/- 0.05 [.088 +/- .002] | 3.2                            |
| 16 AWG    | 1.98 +/- 0.05 [.078 +/- .002] | 6.2                            |
| 18 AWG    | 1.83 +/- 0.05 [.072 +/- .002] | 7.8                            |

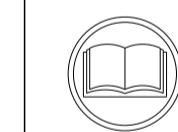

- RECOMMENDED SPARE PARTS
- REFER TO SUPPLIED INSTRUCTION SHEET FOR CLEANING, LUBRICATION AND STORAGE OF APPLICATOR.
- APPLY PART NUMBER 2-23419-6 LOCTITE TO THREADS OF ITEM 242. APPLY PART NUMBER 1-23419-5 LOCTITE TO THREADS OF ITEM 180.
- CRIMP HEIGHT REFERENCE SETTING WAS THE SETTING USED WHEN THE APPLICATOR WAS QUALIFIED AT THE FACTORY. ADJUSTMENT MAY BE NECESSARY WHEN RUNNING APPLICATOR IN THE FIELD.
- TERMINAL PITCH NOT COMPATIBLE WITH MECHANICAL FEED.
- UNLESS SPECIFIED OTHERWISE TORQUE VALUES SHALL BE USED PER DOCUMENT, 101-35000.

**\*WARNING**  
ON INSTALLATION, SET WIRE DISC TO CRIMP HEIGHT REFERENCE SETTING FOR LARGEST WIRE SIZE. CRIMP HEIGHT REFERENCE SETTINGS GREATER THAN THE VALUE SHOWN MAY CAUSE DAMAGE TO THE CRIMP TOOLING. REFER TO THE INSTRUCTION SHEET FOR PROPER SETUP AND ADJUSTMENTS.

| LOC | DIST | REVISIONS |     |             |      |     |      |
|-----|------|-----------|-----|-------------|------|-----|------|
| A   | 66   | P         | LTN | DESCRIPTION | DATE | OWN | APVD |
|     |      | -         |     | SEE SHEET 1 | -    | -   | -    |

|   |       |             |                                     |                           |     |
|---|-------|-------------|-------------------------------------|---------------------------|-----|
| - | 1     | 2119082-3   | CAM, SNAIL, INSULATION ADJUSTMENT   | 244                       |     |
| - | 1     | 2079764-1   | WASHER, WAVE SPRING, CREST-TO-CREST | 243                       |     |
| 3 | -     | 1           | 2119083-1                           | RETAINER, INSULATION DIAL | 242 |
| - | 1     | 2844940-4   | AIR FEED MODULE                     | 238                       |     |
| - | 1     | 1-18028-0   | WASHER, FLAT, REG M8                | 192                       |     |
| - | 4     | 2079383-9   | SCR, BHSC, RoHS (M6 X 20)           | 186                       |     |
| 3 | -     | 1           | 1-1752354-0                         | STANDOFF, HOLD-DOWN       | 180 |
| - | 1     | 6-993111-6  | PIN, SLOTTED SPRING 3.0 X 14.0      | 177                       |     |
| - | 1     | 8-22280-7   | SPRING, COMPRESSION                 | 176                       |     |
| - | 1     | 1752353-2   | GUIDE PIN, HOLDDOWN                 | 175                       |     |
| - | 1     | 1901680-2   | GUIDE PIN, HOLDDOWN                 | 174                       |     |
| - | REF   | 994970-2    | COUNTER, MAGNETIC                   | 164                       |     |
| - | 1     | 2119641-2   | FEED CAM, AIR FEED                  | 152                       |     |
| - | 1     | 2168083-8   | SCR, SKT HD CAP, RoHS, M4 X 16      | 144                       |     |
| - | 2     | 18024-1     | SCR, BTN SKT HD CAP (M3 X 6.0)      | 144                       |     |
| - | 1     | 1-1976053-3 | LOCATER BLOCK, TERMINAL             | 143                       |     |
| - | 1     | 2119655-6   | APPLICATOR BASIC ASSEMBLY, EF       | 141                       |     |
| - | 1     | 1803518-1   | RAM ASSEMBLY, EF PACIFIC            | 140                       |     |
| - | 1     | 455888-4    | SPACER, CRIMPER                     | 82                        |     |
| - | 1     | 2119791-5   | DEPRESSOR, WIRE                     | 73                        |     |
| - | 1     | 1803607-4   | DOCUMENTATION PACKAGE               | 71                        |     |
| - | 2     | 2-18032-2   | SCR, SET, FLT PNT, M3 X 10.0        | 70                        |     |
| - | 1     | 2119943-1   | WASHER, SPACER                      | 69                        |     |
| - | 1     | 2119740-1   | TAG, IDENTIFICATION                 | 67                        |     |
| - | 2     | 2168078-1   | SCREW, DRIVE, RH, RoHS, 2 x .188    | 66                        |     |
| - | 1     | 1901681-8   | HOLDDOWN, TERMINAL                  | 65                        |     |
| - | 1     | 5-18022-5   | SCR, HEX HD CAP, M4 X 6.0           | 59                        |     |
| - | 4     | 2168400-4   | SHCS, LOW HEAD, RoHS, M4 X 8        | 57                        |     |
| - | 2     | 2168083-9   | SCR, SKT HD CAP, RoHS, M4 X 20      | 56                        |     |
| - | 2     | 5018030-1   | NUT, HEX, REG, RoHS, M3             | 54                        |     |
| - | 2     | 986965-8    | NUT, LOCK, HEX, TORQUE (M4)         | 53                        |     |
| - | 1     | 1-5018030-0 | NUT, HEX, REG, RoHS, M3.5           | 52                        |     |
| - | 1     | 2063961-1   | FEED FINGER                         | 51                        |     |
| - | 1     | 18023-9     | SCR, SKT HD CAP M4 X 6.0            | 49                        |     |
| - | 1     | 1803602-1   | SCR, BHSC, RoHS (M8 X 25)           | 41                        |     |
| - | 8     | 1-18028-2   | WASHER, FLAT, REG M4                | 33                        |     |
| - | 2     | 2168083-9   | SCR, SKT HD CAP, RoHS, M4 X 20      | 31                        |     |
| - | 2     | 2168083-2   | SCR, SKT HD CAP, RoHS, M4 X 8.0     | 29                        |     |
| - | 1     | 240639-1    | STRIPPER (MACHINING)                | 27                        |     |
| - | 2     | 1-2168083-5 | SCR, SKT HD CAP, RoHS, M4 X 30      | 25                        |     |
| - | 1     | 1752371-5   | PLATE, STRIP GUIDE                  | 24                        |     |
| - | 2     | 2-22281-3   | SPRING, COMPRESSION                 | 22                        |     |
| - | 1     | 1803292-4   | DRAG                                | 20                        |     |
| - | 1     | 1-1901696-9 | STRIP GUIDE, REAR                   | 19                        |     |
| - | 1     | 1-1901695-9 | STRIP GUIDE, FRONT                  | 18                        |     |
| - | 1     | 240641-4    | SPACER                              | 16                        |     |
| - | 1     | 1752360-1   | SPACER, HOLD-DOWN                   | 13                        |     |
| 1 | -     | 1           | 240644-1                            | PLATE, REAR SHEAR         | 11  |
| - | 2     | 1-240645-4  | SPACER, SHEAR PLATE                 | 10                        |     |
| 1 | -     | 1           | 240642-4                            | PLATE, FRONT SHEAR        | 9   |
| 1 | 1     | 6-1633383-6 | ANVIL, COMBINATION                  | 8                         |     |
| 1 | -     | 1           | 9-240651-1                          | BLADE, SLUG               | 7   |
| - | -     | -           | -                                   | 6                         |     |
| - | 1     | 5-240641-5  | SPACER                              | 5                         |     |
| - | 1     | 238011-2    | BLOCK, CRIMPER SPACER               | 4                         |     |
| 1 | 1     | 6-2119784-0 | CRIMPER, INSULATION O PREMIUM       | 3                         |     |
| - | 1     | 455888-3    | SPACER, CRIMPER                     | 2                         |     |
| 1 | 1     | 456407-4    | CRIMPER, WIRE PREMIUM               | 1                         |     |
| - | 77-22 | PART NO     | DESCRIPTION                         | ITEM NO                   |     |

PACIFIC VERSION  
Shown on sheets 3 of 4 & 4 of 4  
(Atlantic version shown on sheets 1 of 4 & 2 of 4)

|             |         |                                        |            |                          |          |                           |              |                                                 |                  |
|-------------|---------|----------------------------------------|------------|--------------------------|----------|---------------------------|--------------|-------------------------------------------------|------------------|
| DIMENSIONS: |         | TOLERANCES UNLESS OTHERWISE SPECIFIED: |            | DWG: B. WEAVER 23DEC2014 |          | CHK: G. BAILEY 23DEC2014  |              | NAME: TE Connectivity Harrisburg, PA 17105-3608 |                  |
| mm          | 0 PLC ± | 1 PLC ±                                | 2 PLC ±    | 3 PLC ±                  | 4 PLC ±  | APVD: G. BAILEY 23DEC2014 | PRODUCT SPEC | SIZE: A1                                        | CAGE CODE: 00779 |
| MATERIAL:   | FINISH: | WEIGHT:                                | SCALE: 1:1 | DRAWING NO: 2150522      | SHEET: 3 | OF: 4                     | REV: C       | Customer Accessible Production Drawing          |                  |

| LOC | DIST | REV | DESCRIPTION | DATE | OWN | APVD |
|-----|------|-----|-------------|------|-----|------|
| A   | 66   |     | SEE SHEET 1 |      |     |      |

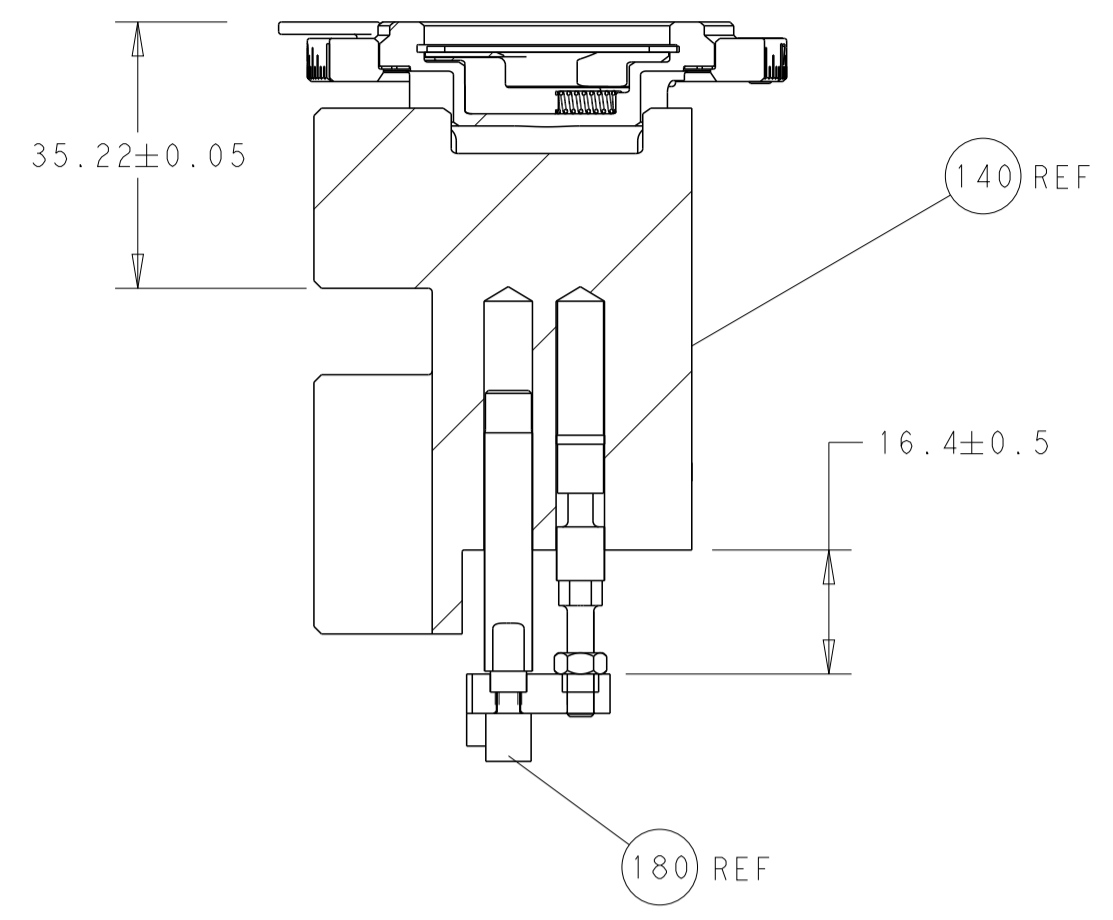

RAM AND HOLDDOWN SET-UP

FEED TYPE

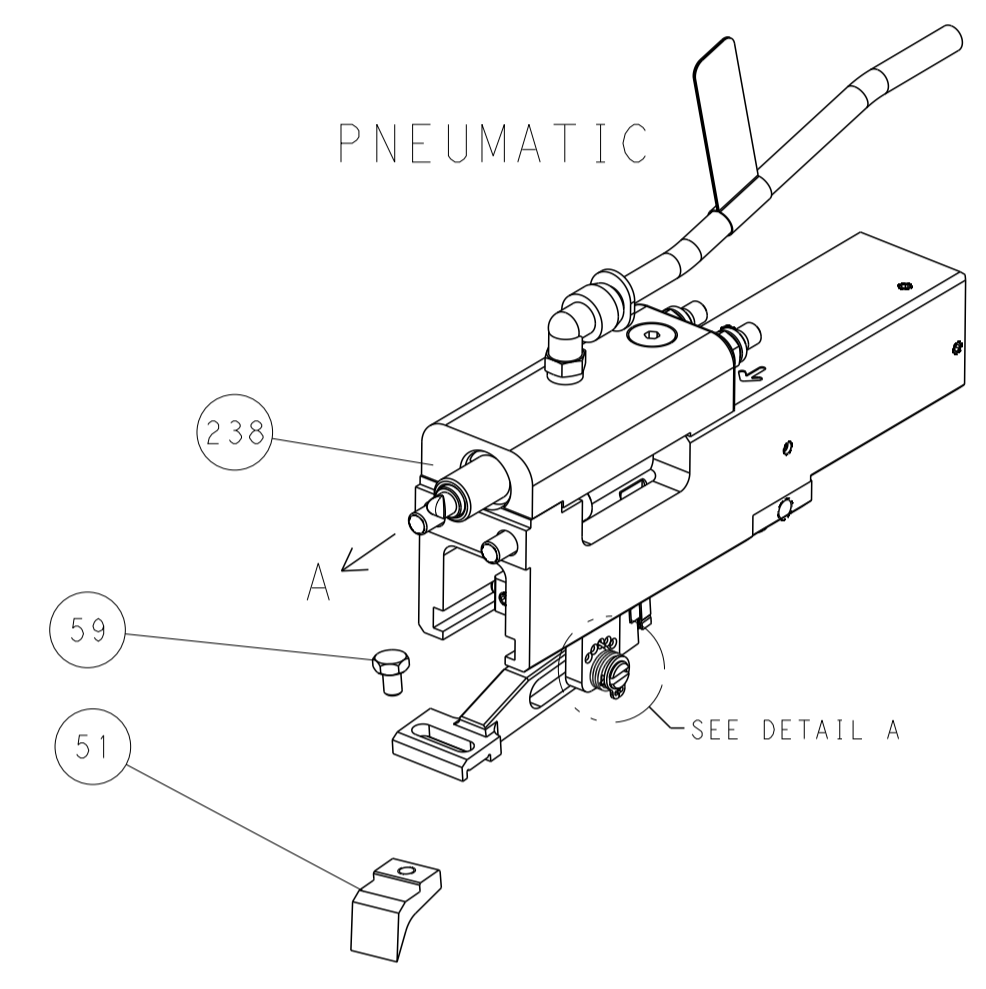

FEED SPRING SETTING POSITION

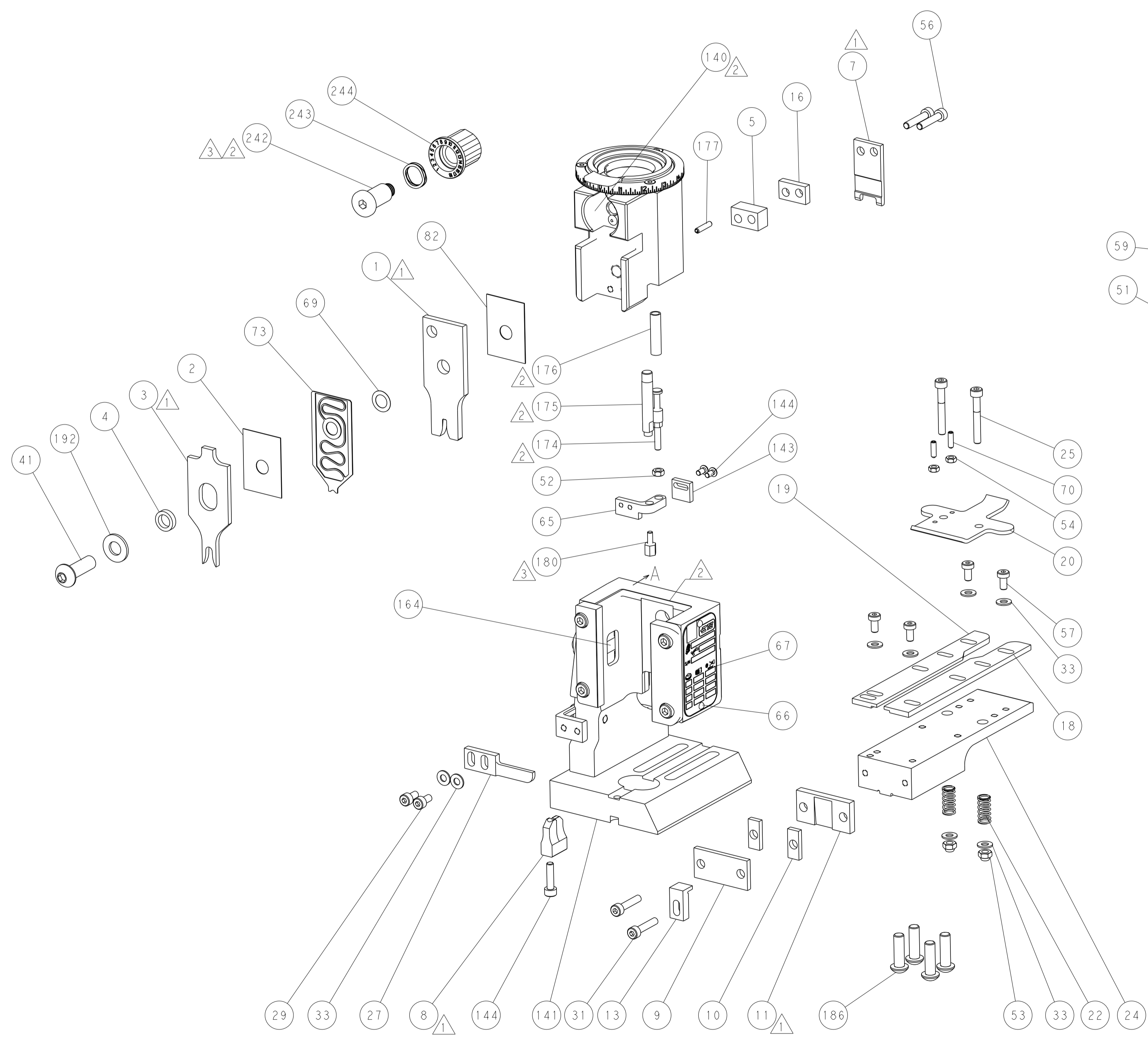
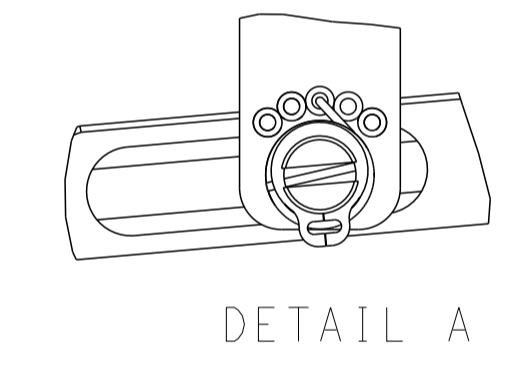

CAM POSITION

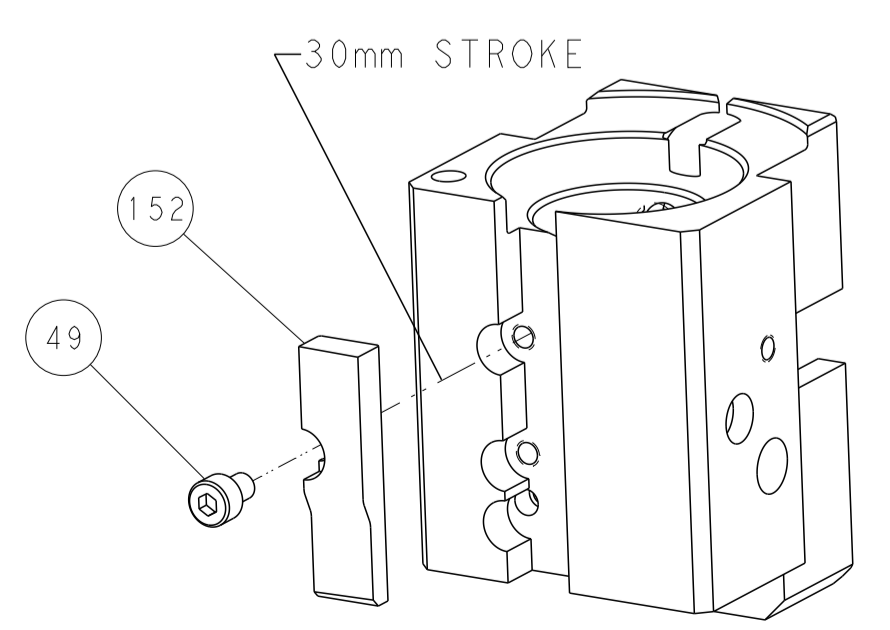

AIR FEED

PACIFIC VERSION  
 Shown on sheets 3 of 4 & 4 of 4  
 (Atlantic version shown on sheets 1 of 4 & 2 of 4)

|                                                                                                                                                         |                                                                                                                                       |                                                                                   |                                                                                        |                                                   |
|---------------------------------------------------------------------------------------------------------------------------------------------------------|---------------------------------------------------------------------------------------------------------------------------------------|-----------------------------------------------------------------------------------|----------------------------------------------------------------------------------------|---------------------------------------------------|
| <small>THIS DRAWING IS UNPUBLISHED. RELEASED FOR PUBLICATION 2014 BY TYCO ELECTRONICS CORPORATION. ALL RIGHTS RESERVED.</small>                         |                                                                                                                                       | DWN: B. WEAVER 23DEC2014<br>CHK: G. BAILEY 23DEC2014<br>APVD: G. BAILEY 23DEC2014 | NAME: Ocean End Feed Applicator<br>SIZE: A1<br>CAGE CODE: 00779<br>DRAWING NO: 2150522 | RESTRICTED TO: C                                  |
| DIMENSIONS: mm<br>TOLERANCES UNLESS OTHERWISE SPECIFIED:<br>0 PLC ±<br>1 PLC ±<br>2 PLC ±<br>3 PLC ±<br>4 PLC ±<br>ANGLES ±<br>MATERIAL: -<br>FINISH: - | TOLERANCES UNLESS OTHERWISE SPECIFIED:<br>0 PLC ±<br>1 PLC ±<br>2 PLC ±<br>3 PLC ±<br>4 PLC ±<br>ANGLES ±<br>MATERIAL: -<br>FINISH: - | WEIGHT: -<br>SCALE: 1:1<br>SHEET: 4 OF 4<br>REV: C                                | CUSTOMER ACCESSIBLE PRODUCTION DRAWING                                                 | SHEETS 1 & 2 ARE NOT REQUIRED FOR PACIFIC VERSION |