

## Very low drop voltage regulators with inhibit

### Features

- Very low dropout voltage (0.4 V)
- Very low quiescent current (typ. 50  $\mu$ A in OFF mode, 500  $\mu$ A in ON mode)
- Output current up to 500 mA
- Logic-controlled electronic shutdown
- Output voltages of 1.5; 2.5; 3.3; 4; 5; 8 V
- Internal current and thermal limit
- Only 2.2  $\mu$ F for stability
- Available in  $\pm 2$  % accuracy at 25 °C
- Supply voltage rejection: 70 db (typ.)
- Temperature range: -40 to 125 °C

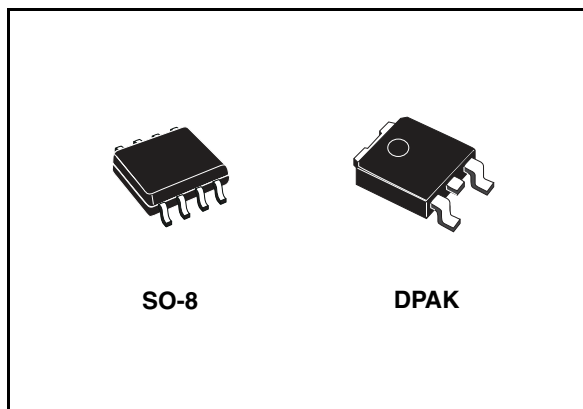

### Description

The KFxx series are very low drop regulators available in SO-8 package and in a wide range of output voltages.

The very low drop voltage (0.4 V) and the very low quiescent current make them particularly

suitable for low noise, low power applications and specially in battery powered systems.

A shutdown logic control function is available (pin 5, TTL compatible). This means that when the device is used as a local regulator, it is possible to put a part of the board in standby, decreasing the total power consumption. It requires only a 2.2  $\mu$ F capacitor for stability allowing space and cost saving.

**Table 1. Device summary**

Part numbers	
KF15B	KF40B
KF25B	KF50B
KF33B	KF80B

---

# Contents

1	Diagram .....	3
2	Pin configuration .....	4
3	Maximum ratings .....	5
4	Electrical characteristics .....	6
5	Typical performance characteristics .....	12
6	Package mechanical data .....	13
7	Order codes .....	18
8	Revision history .....	19

# 1 Diagram

Figure 1. Schematic diagram

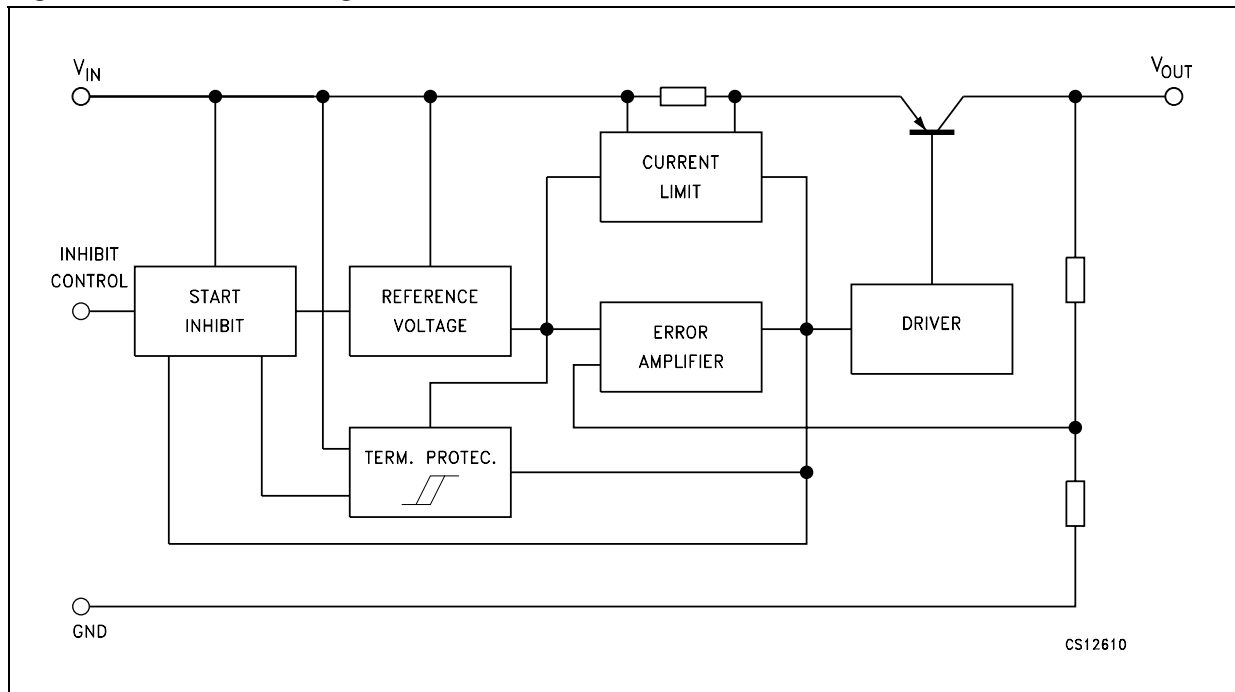

## 2 Pin configuration

Figure 2. Pin connections (top view)

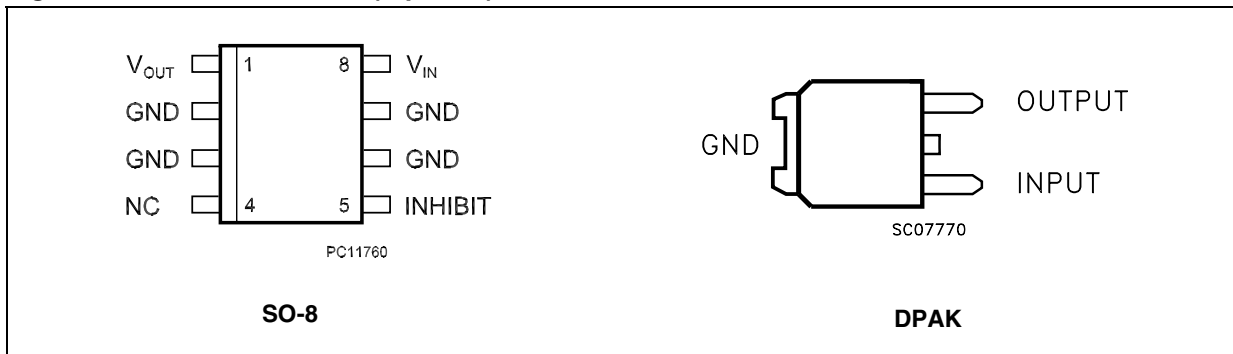

### 3 Maximum ratings

**Table 2. Absolute maximum ratings**

Symbol	Parameter	Value	Unit
$V_I$	DC input voltage	-0.5 to 20	V
$I_O$	Output current	Internally Limited	
$P_{TOT}$	Power dissipation	Internally Limited	
$T_{STG}$	Storage temperature range	-40 to 150	°C
$T_{OP}$	Operating junction temperature range	-40 to 125	°C

*Note: Absolute maximum ratings are those values beyond which damage to the device may occur. Functional operation under these condition is not implied.*

**Table 3. Thermal data**

Symbol	Parameter	DPAK	SO-8	Unit
$R_{thJC}$	Thermal resistance junction-case	8	20	°C/W

**Figure 3. Test circuit**

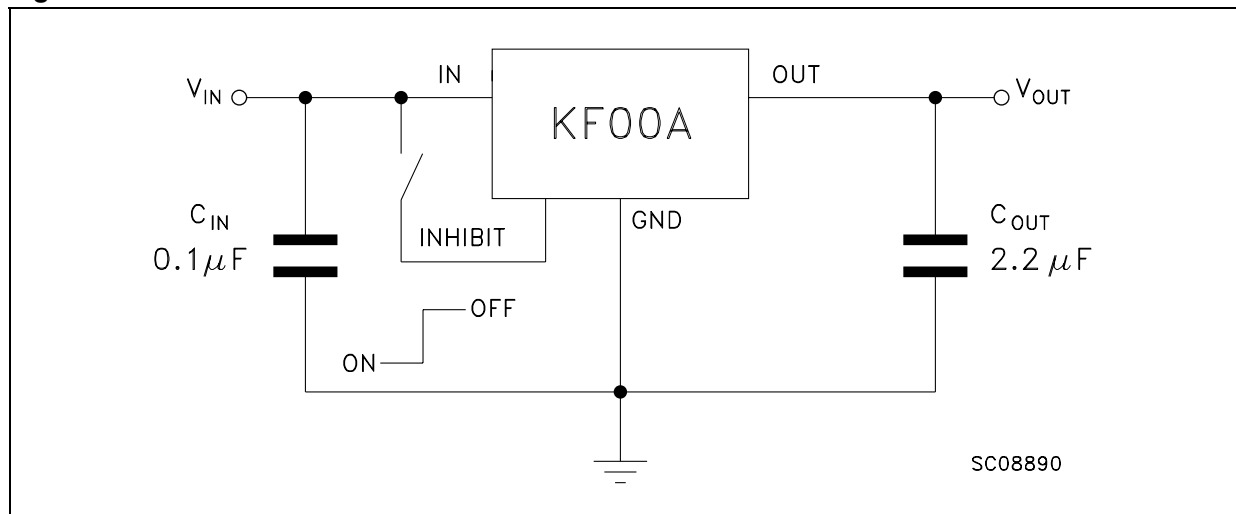

## 4 Electrical characteristics

**Table 4. Electrical characteristics for KF15** (refer to the test circuits,  $T_J = 25\text{ }^\circ\text{C}$ ,  $C_I = 0.1\text{ }\mu\text{F}$ ,  $C_O = 2.2\text{ }\mu\text{F}$  unless otherwise specified.)

Symbol	Parameter	Test conditions	Min.	Typ.	Max.	Unit	
$V_O$	Output voltage	$I_O = 50\text{ mA}$ , $V_I = 3.5\text{ V}$	1.47	1.5	1.53	V	
		$I_O = 50\text{ mA}$ , $V_I = 3.5\text{ V}$ , $T_a = -25\text{ to }85\text{ }^\circ\text{C}$	1.44		1.56		
$V_I$	Operating input voltage	$I_O = 500\text{ mA}$	2.5		20	V	
$I_O$	Output current limit			1		A	
$\Delta V_O$	Line regulation	$V_I = 2.5\text{ to }20\text{ V}$ , $I_O = 5\text{ mA}$		2	12	mV	
$\Delta V_O$	Load regulation	$V_I = 2.8\text{ V}$ , $I_O = 5\text{ to }500\text{ mA}$		2	50	mV	
$I_d$	Quiescent current	$V_I = 2.5\text{ to }20\text{ V}$ , $I_O = 0\text{ mA}$	ON MODE		0.5	1	mA
		$V_I = 2.8\text{ to }20\text{ V}$ , $I_O = 500\text{ mA}$				12	
		$V_I = 6\text{ V}$	OFF MODE		50	100	$\mu\text{A}$
SVR	Supply voltage rejection	$I_O = 5\text{ mA}$ , $V_I = 3.5 \pm 1\text{ V}$	$f = 120\text{ Hz}$		82	dB	
			$f = 1\text{ kHz}$		77		
			$f = 10\text{ kHz}$		60		
eN	Output noise voltage	$B = 10\text{ Hz to }100\text{ kHz}$		50		$\mu\text{V}$	
$V_d$	Dropout voltage	$I_O = 200\text{ mA}$		1		V	
$V_{IL}$	Control input logic low	$T_a = -40\text{ to }125\text{ }^\circ\text{C}$			0.8	V	
$V_{IH}$	Control input logic high	$T_a = -40\text{ to }125\text{ }^\circ\text{C}$	2			V	
$I_I$	Control input current	$V_I = 6\text{ V}$ , $V_C = 6\text{ V}$		10		$\mu\text{A}$	
$C_O$	Output bypass capacitance	$\text{ESR} = 0.1\text{ to }10\text{ }\Omega$ , $I_O = 0\text{ to }500\text{ mA}$	2	10		$\mu\text{F}$	

**Table 5. Electrical characteristics for KF25** (refer to the test circuits,  $T_J = 25\text{ }^\circ\text{C}$ ,  $C_I = 0.1\text{ }\mu\text{F}$ ,  $C_O = 2.2\text{ }\mu\text{F}$  unless otherwise specified.)

Symbol	Parameter	Test conditions	Min.	Typ.	Max.	Unit
$V_O$	Output voltage	$I_O = 50\text{ mA}$ , $V_I = 4.5\text{ V}$	2.45	2.5	2.55	V
		$I_O = 50\text{ mA}$ , $V_I = 4.5\text{ V}$ , $T_a = -25\text{ to }85\text{ }^\circ\text{C}$	2.4		2.6	
$V_I$	Operating input voltage	$I_O = 500\text{ mA}$			20	V
$I_O$	Output current limit			1		A
$\Delta V_O$	Line regulation	$V_I = 3.5\text{ to }20\text{ V}$ , $I_O = 5\text{ mA}$		2	12	mV
$\Delta V_O$	Load regulation	$V_I = 3.8\text{ V}$ , $I_O = 5\text{ to }500\text{ mA}$		2	50	mV
$I_d$	Quiescent current	$V_I = 3.5\text{ to }20\text{ V}$ , $I_O = 0\text{ mA}$	ON MODE	0.5	1	mA
		$V_I = 3.8\text{ to }20\text{ V}$ , $I_O = 500\text{ mA}$				
		$V_I = 6\text{ V}$	OFF MODE	50	100	$\mu\text{A}$
SVR	Supply voltage rejection	$I_O = 5\text{ mA}$ , $V_I = 4.5 \pm 1\text{ V}$	$f = 120\text{ Hz}$	82		dB
			$f = 1\text{ kHz}$	77		
			$f = 10\text{ kHz}$	60		
eN	Output noise voltage	$B = 10\text{ Hz to }100\text{ KHz}$		50		$\mu\text{V}$
$V_d$	Dropout voltage	$I_O = 200\text{ mA}$		0.2	0.35	V
		$I_O = 500\text{ mA}$		0.4	0.7	
$V_{IL}$	Control input logic low	$T_a = -40\text{ to }125\text{ }^\circ\text{C}$			0.8	V
$V_{IH}$	Control input logic high	$T_a = -40\text{ to }125\text{ }^\circ\text{C}$	2			V
$I_I$	Control input current	$V_I = 6\text{ V}$ , $V_C = 6\text{ V}$		10		$\mu\text{A}$
$C_O$	Output bypass capacitance	$\text{ESR} = 0.1\text{ to }10\text{ }\Omega$ , $I_O = 0\text{ to }500\text{ mA}$	2	10		$\mu\text{F}$

**Table 6. Electrical characteristics for KF33** (refer to the test circuits,  $T_J = 25\text{ }^\circ\text{C}$ ,  $C_I = 0.1\text{ }\mu\text{F}$ ,  $C_O = 2.2\text{ }\mu\text{F}$  unless otherwise specified.)

Symbol	Parameter	Test conditions	Min.	Typ.	Max.	Unit
$V_O$	Output voltage	$I_O = 50\text{ mA}$ , $V_I = 5.3\text{ V}$	3.234	3.3	3.366	V
		$I_O = 50\text{ mA}$ , $V_I = 5.3\text{ V}$ , $T_a = -25\text{ to }85\text{ }^\circ\text{C}$	3.168		3.432	
$V_I$	Operating input voltage	$I_O = 500\text{ mA}$			20	V
$I_O$	Output current limit			1		A
$\Delta V_O$	Line regulation	$V_I = 4.3\text{ to }20\text{ V}$ , $I_O = 5\text{ mA}$		2	12	mV
$\Delta V_O$	Load regulation	$V_I = 4.6\text{ V}$ , $I_O = 5\text{ to }500\text{ mA}$		2	50	mV
$I_d$	Quiescent current	$V_I = 4.3\text{ to }20\text{ V}$ , $I_O = 0\text{ mA}$	ON MODE	0.5	1	mA
		$V_I = 4.6\text{ to }20\text{ V}$ , $I_O = 500\text{ mA}$				
		$V_I = 6\text{ V}$	OFF MODE	50	100	$\mu\text{A}$
SVR	Supply voltage rejection	$I_O = 5\text{ mA}$ , $V_I = 5.3 \pm 1\text{ V}$	$f = 120\text{ Hz}$	80		dB
			$f = 1\text{ kHz}$	75		
			$f = 10\text{ kHz}$	60		
eN	Output noise voltage	$B = 10\text{ Hz to }100\text{ KHz}$		50		$\mu\text{V}$
$V_d$	Dropout voltage	$I_O = 200\text{ mA}$		0.2	0.35	V
		$I_O = 500\text{ mA}$		0.4	0.7	
$V_{IL}$	Control input logic low	$T_a = -40\text{ to }125\text{ }^\circ\text{C}$			0.8	V
$V_{IH}$	Control input logic high	$T_a = -40\text{ to }125\text{ }^\circ\text{C}$	2			V
$I_I$	Control input current	$V_I = 6\text{ V}$ , $V_C = 6\text{ V}$		10		$\mu\text{A}$
$C_O$	Output bypass capacitance	$\text{ESR} = 0.1\text{ to }10\text{ }\Omega$ , $I_O = 0\text{ to }500\text{ mA}$	2	10		$\mu\text{F}$



**Table 7. Electrical characteristics for KF40** (refer to the test circuits,  $T_J = 25\text{ }^\circ\text{C}$ ,  $C_I = 0.1\text{ }\mu\text{F}$ ,  $C_O = 2.2\text{ }\mu\text{F}$  unless otherwise specified.)

Symbol	Parameter	Test conditions	Min.	Typ.	Max.	Unit
$V_O$	Output voltage	$I_O = 50\text{ mA}$ , $V_I = 6\text{ V}$	3.92	4	4.08	V
		$I_O = 50\text{ mA}$ , $V_I = 6\text{ V}$ , $T_a = -25\text{ to }85\text{ }^\circ\text{C}$	3.84		4.16	
$V_I$	Operating input voltage	$I_O = 500\text{ mA}$			20	V
$I_O$	Output current limit			1		A
$\Delta V_O$	Line regulation	$V_I = 5\text{ to }20\text{ V}$ , $I_O = 5\text{ mA}$		3	18	mV
$\Delta V_O$	Load regulation	$V_I = 5.3\text{ V}$ , $I_O = 5\text{ to }500\text{ mA}$		2	50	mV
$I_d$	Quiescent current	$V_I = 5\text{ to }20\text{ V}$ , $I_O = 0\text{ mA}$	ON MODE	0.5	1	mA
		$V_I = 5.3\text{ to }20\text{ V}$ , $I_O = 500\text{ mA}$			12	
		$V_I = 6\text{ V}$	OFF MODE	50	100	$\mu\text{A}$
SVR	Supply voltage rejection	$I_O = 5\text{ mA}$ , $V_I = 6 \pm 1\text{ V}$	$f = 120\text{ Hz}$	78		dB
			$f = 1\text{ kHz}$	73		
			$f = 10\text{ kHz}$	60		
eN	Output noise voltage	$B = 10\text{ Hz to }100\text{ KHz}$		50		$\mu\text{V}$
$V_d$	Dropout voltage	$I_O = 200\text{ mA}$		0.2	0.35	V
		$I_O = 500\text{ mA}$		0.4	0.7	
$V_{IL}$	Control input logic low	$T_a = -40\text{ to }125\text{ }^\circ\text{C}$			0.8	V
$V_{IH}$	Control input logic high	$T_a = -40\text{ to }125\text{ }^\circ\text{C}$	2			V
$I_I$	Control input current	$V_I = 6\text{ V}$ , $V_C = 6\text{ V}$		10		$\mu\text{A}$
$C_O$	Output bypass capacitance	$\text{ESR} = 0.1\text{ to }10\text{ }\Omega$ , $I_O = 0\text{ to }500\text{ mA}$	2	10		$\mu\text{F}$

**Table 8. Electrical characteristics for KF50** (refer to the test circuits,  $T_J = 25\text{ }^\circ\text{C}$ ,  $C_I = 0.1\text{ }\mu\text{F}$ ,  $C_O = 2.2\text{ }\mu\text{F}$  unless otherwise specified.)

Symbol	Parameter	Test conditions	Min.	Typ.	Max.	Unit
$V_O$	Output voltage	$I_O = 50\text{ mA}$ , $V_I = 7\text{ V}$	4.9	5	5.1	V
		$I_O = 50\text{ mA}$ , $V_I = 7\text{ V}$ , $T_a = -25\text{ to }85\text{ }^\circ\text{C}$	4.8		5.2	
$V_I$	Operating input voltage	$I_O = 500\text{ mA}$			20	V
$I_O$	Output current limit			1		A
$\Delta V_O$	Line regulation	$V_I = 6\text{ to }20\text{ V}$ , $I_O = 5\text{ mA}$		3	18	mV
$\Delta V_O$	Load regulation	$V_I = 6.3\text{ V}$ , $I_O = 5\text{ to }500\text{ mA}$		2	50	mV
$I_d$	Quiescent current	$V_I = 6\text{ to }20\text{ V}$ , $I_O = 0\text{ mA}$	ON MODE	0.5	1	mA
		$V_I = 6.3\text{ to }20\text{ V}$ , $I_O = 500\text{ mA}$			12	
		$V_I = 6\text{ V}$	OFF MODE	50	100	$\mu\text{A}$
SVR	Supply voltage rejection	$I_O = 5\text{ mA}$ , $V_I = 7 \pm 1\text{ V}$	$f = 120\text{ Hz}$	76		dB
			$f = 1\text{ kHz}$	71		
			$f = 10\text{ kHz}$	60		
eN	Output noise voltage	$B = 10\text{ Hz to }100\text{ KHz}$		50		$\mu\text{V}$
$V_d$	Dropout voltage	$I_O = 200\text{ mA}$		0.2	0.35	V
		$I_O = 500\text{ mA}$		0.4	0.7	
$V_{IL}$	Control input logic low	$T_a = -40\text{ to }125\text{ }^\circ\text{C}$			0.8	V
$V_{IH}$	Control input logic high	$T_a = -40\text{ to }125\text{ }^\circ\text{C}$	2			V
$I_I$	Control input current	$V_I = 6\text{ V}$ , $V_C = 6\text{ V}$		10		$\mu\text{A}$
$C_O$	Output bypass capacitance	$\text{ESR} = 0.1\text{ to }10\text{ }\Omega$ , $I_O = 0\text{ to }500\text{ mA}$	2	10		$\mu\text{F}$

**Table 9. Electrical characteristics for KF80** (refer to the test circuits,  $T_J = 25\text{ }^\circ\text{C}$ ,  $C_I = 0.1\text{ }\mu\text{F}$ ,  $C_O = 2.2\text{ }\mu\text{F}$  unless otherwise specified.)

Symbol	Parameter	Test conditions	Min.	Typ.	Max.	Unit
$V_O$	Output voltage	$I_O = 50\text{ mA}$ , $V_I = 10\text{ V}$	7.84	8	8.16	V
		$I_O = 50\text{ mA}$ , $V_I = 10\text{ V}$ , $T_a = -25\text{ to }85\text{ }^\circ\text{C}$	7.68		8.32	
$V_I$	Operating input voltage	$I_O = 500\text{ mA}$			20	V
$I_O$	Output current limit			1		A
$\Delta V_O$	Line regulation	$V_I = 9\text{ to }20\text{ V}$ , $I_O = 5\text{ mA}$		4	24	mV
$\Delta V_O$	Load regulation	$V_I = 9.3\text{ V}$ , $I_O = 5\text{ to }500\text{ mA}$		2	50	mV
$I_d$	Quiescent current	$V_I = 9\text{ to }20\text{ V}$ , $I_O = 0\text{ mA}$	ON MODE	0.7	1.5	mA
		$V_I = 9.3\text{ to }20\text{ V}$ , $I_O = 500\text{ mA}$			12	
		$V_I = 9\text{ V}$	OFF MODE	70	140	$\mu\text{A}$
SVR	Supply voltage rejection	$I_O = 5\text{ mA}$ , $V_I = 10 \pm 1\text{ V}$	$f = 120\text{ Hz}$	72		dB
			$f = 1\text{ kHz}$	67		
			$f = 10\text{ kHz}$	60		
eN	Output noise voltage	$B = 10\text{ Hz to }100\text{ KHz}$		50		$\mu\text{V}$
$V_d$	Dropout voltage	$I_O = 200\text{ mA}$		0.2	0.35	V
		$I_O = 500\text{ mA}$		0.4	0.7	
$V_{IL}$	Control input logic low	$T_a = -40\text{ to }125\text{ }^\circ\text{C}$			0.8	V
$V_{IH}$	Control input logic high	$T_a = -40\text{ to }125\text{ }^\circ\text{C}$	2			V
$I_I$	Control input current	$V_I = 6\text{ V}$ , $V_C = 6\text{ V}$		10		$\mu\text{A}$
$C_O$	Output bypass capacitance	$\text{ESR} = 0.1\text{ to }10\text{ }\Omega$ , $I_O = 0\text{ to }500\text{ mA}$	2	10		$\mu\text{F}$

# 5 Typical performance characteristics

(unless otherwise specified  $V_{O(NOM)} = 3.3\text{ V}$ )

**Figure 4. Dropout voltage vs output current**      **Figure 5. Dropout voltage vs temperature**

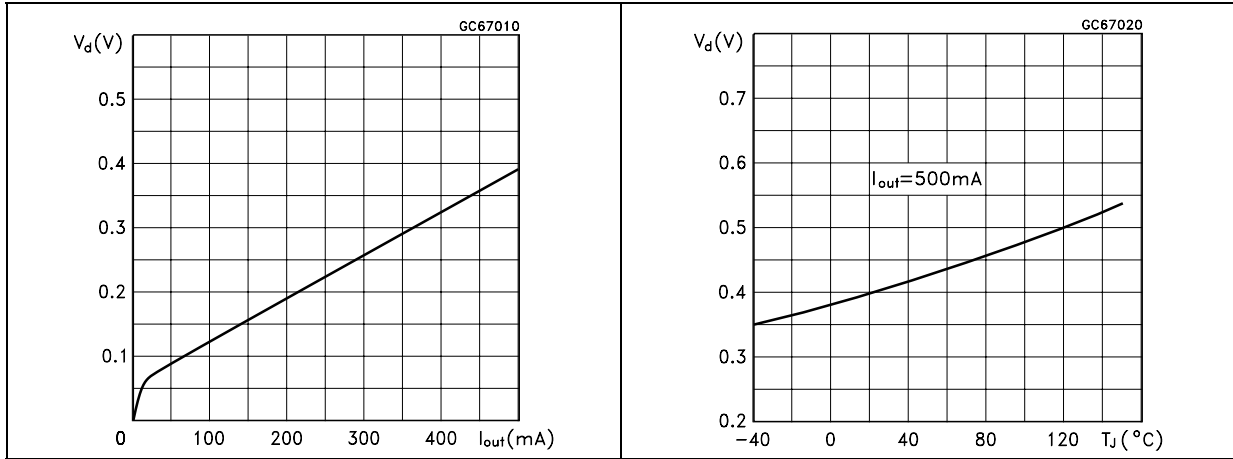

**Figure 6. Supply current vs input voltage**      **Figure 7. Supply current vs input voltage**

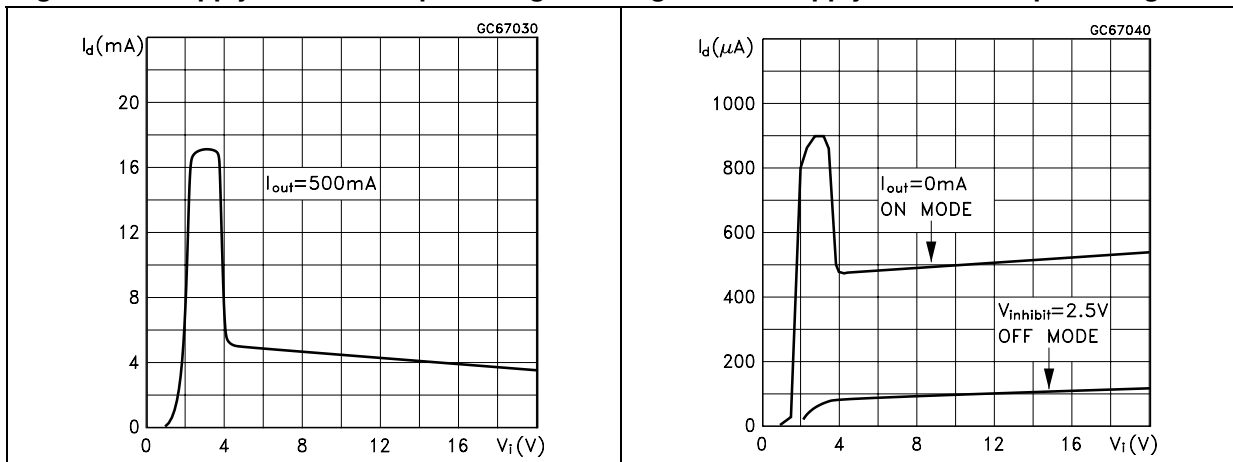

**Figure 8. Short circuit current vs input voltage**      **Figure 9. Supply current vs temperature**

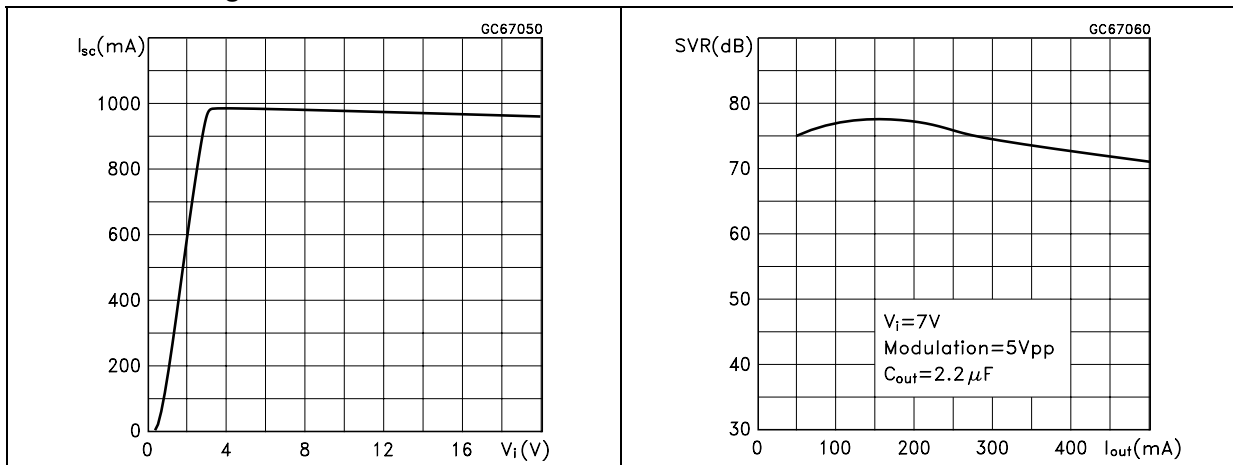

## 6 Package mechanical data

In order to meet environmental requirements, ST offers these devices in ECOPACK<sup>®</sup> packages. These packages have a lead-free second level interconnect. The category of second Level Interconnect is marked on the package and on the inner box label, in compliance with JEDEC Standard JESD97. The maximum ratings related to soldering conditions are also marked on the inner box label. ECOPACK is an ST trademark. ECOPACK specifications are available at: [www.st.com](http://www.st.com).

**SO-8 mechanical data**

Dim.	mm.			inch.		
	Min.	Typ.	Max.	Min.	Typ.	Max.
A	1.35		1.75	0.053		0.069
A1	0.10		0.25	0.04		0.010
A2	1.10		1.65	0.043		0.065
B	0.33		0.51	0.013		0.020
C	0.19		0.25	0.007		0.010
D	4.80		5.00	0.189		0.197
E	3.80		4.00	0.150		0.157
e		1.27			0.050	
H	5.80		6.20	0.228		0.244
h	0.25		0.50	0.010		0.020
L	0.40		1.27	0.016		0.050
k	8° (max.)					
ddd			0.1			0.04

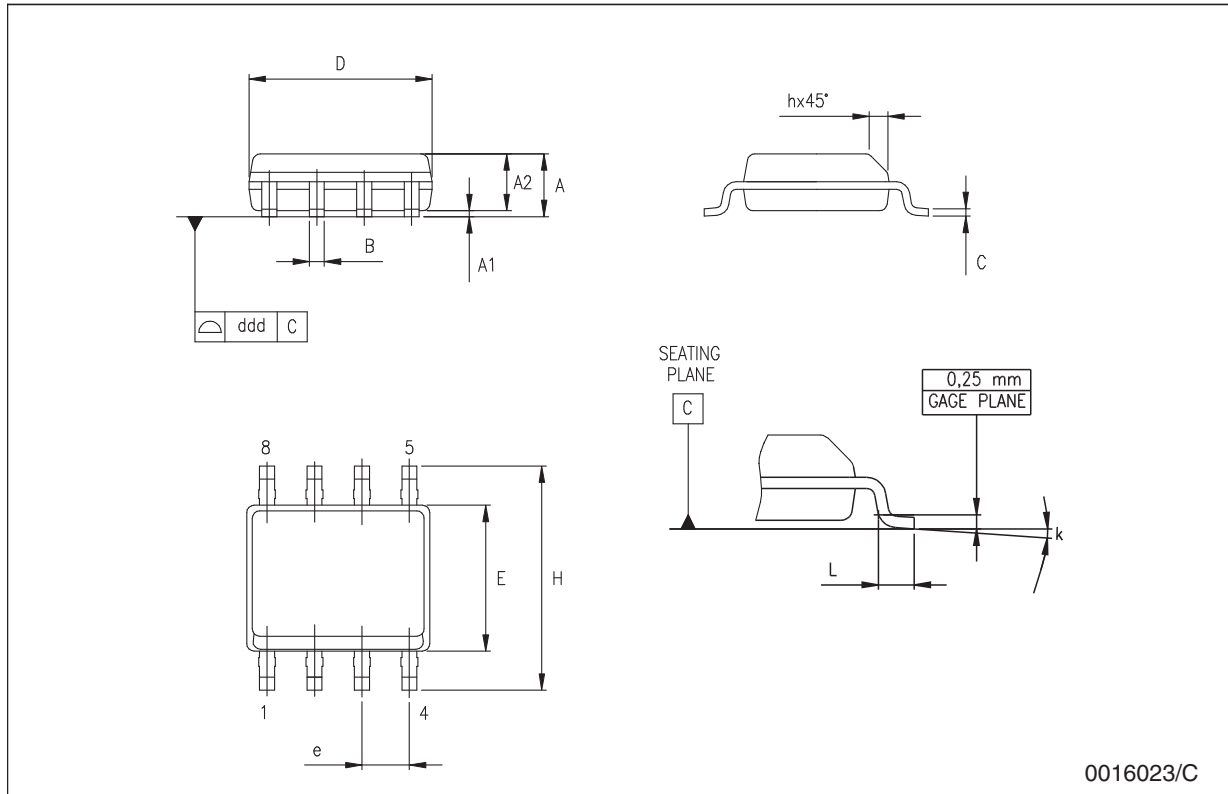

0016023/C



**Tape & reel SO-8 mechanical data**

Dim.	mm.			inch.		
	Min.	Typ.	Max.	Min.	Typ.	Max.
A			330			12.992
C	12.8		13.2	0.504		0.519
D	20.2			0.795		
N	60			2.362		
T			22.4			0.882
Ao	8.1		8.5	0.319		0.335
Bo	5.5		5.9	0.216		0.232
Ko	2.1		2.3	0.082		0.090
Po	3.9		4.1	0.153		0.161
P	7.9		8.1	0.311		0.319

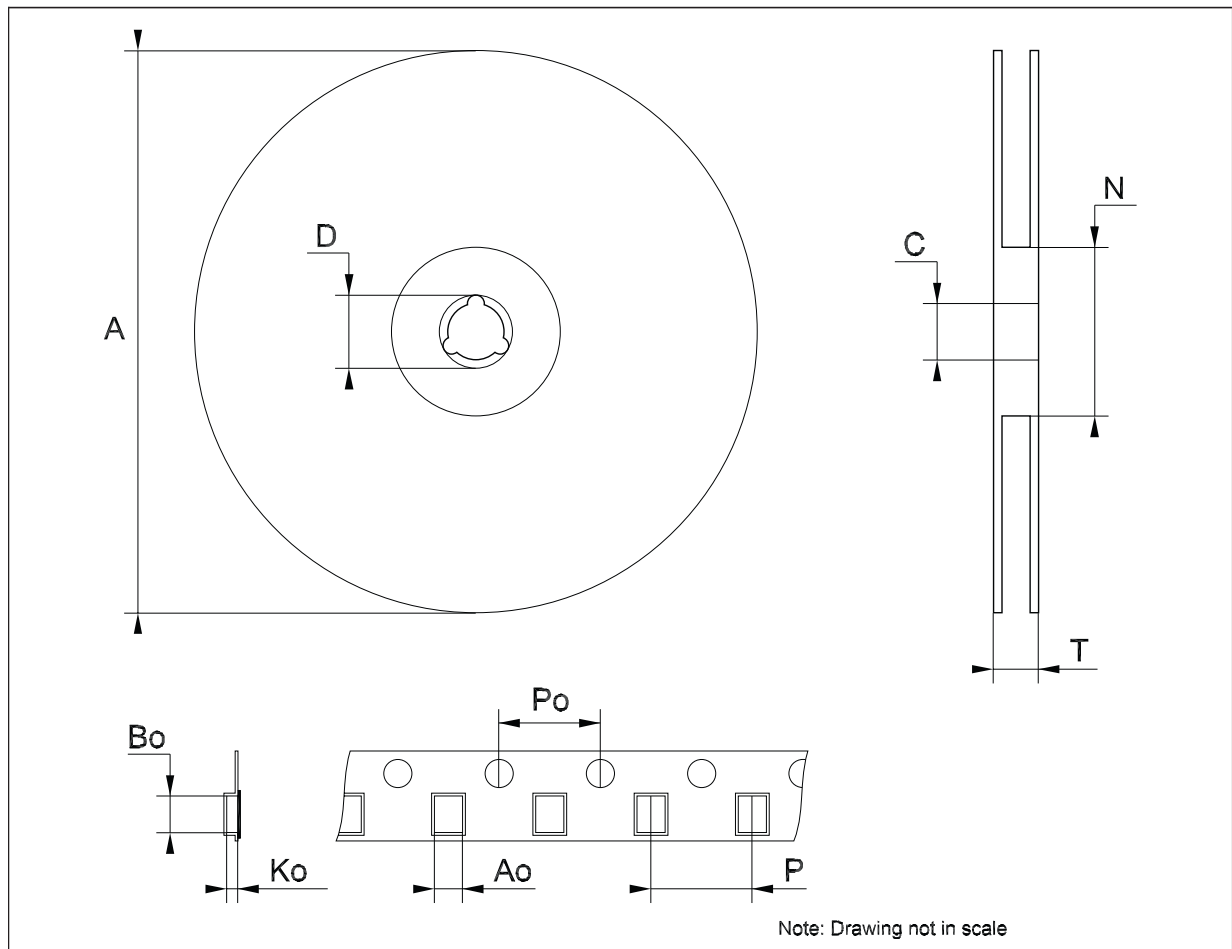



**Tape & reel DPAK-PPAK mechanical data**

Dim.	mm.			inch.		
	Min.	Typ.	Max.	Min.	Typ.	Max.
A			330			12.992
C	12.8	13.0	13.2	0.504	0.512	0.519
D	20.2			0.795		
N	60			2.362		
T			22.4			0.882
Ao	6.80	6.90	7.00	0.268	0.272	0.276
Bo	10.40	10.50	10.60	0.409	0.413	0.417
Ko	2.55	2.65	2.75	0.100	0.104	0.105
Po	3.9	4.0	4.1	0.153	0.157	0.161
P	7.9	8.0	8.1	0.311	0.315	0.319

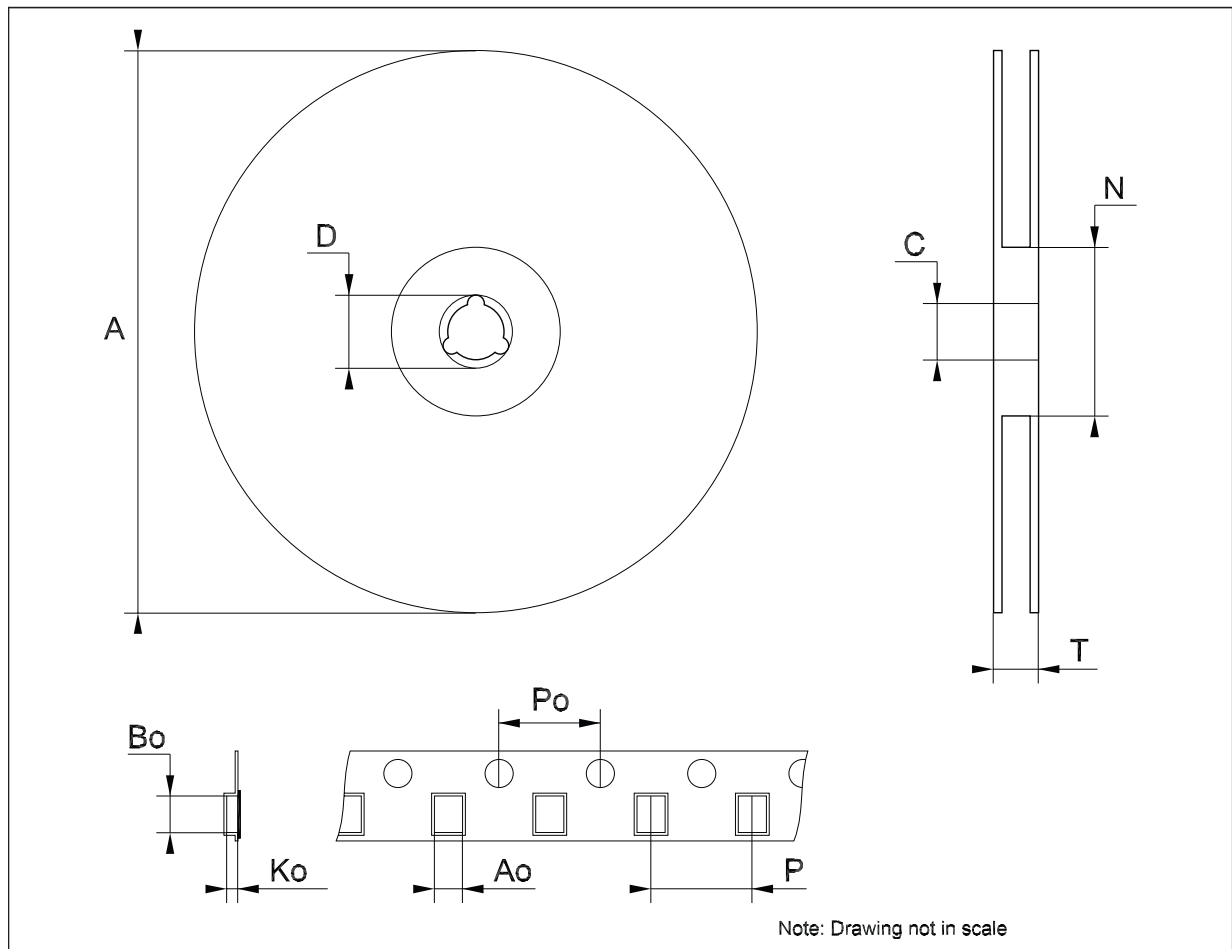

## 7 Order codes

Table 10. Order codes

Packages		Output voltage
SO-8 (tape and reel)	DPAK (tape and reel)	
	KF15BDT-TR	1.5 V
KF25BD-TR	KF25BDT-TR	2.5 V
KF33BD-TR	KF33BDT-TR	3.3 V
	KF40BDT-TR	4 V
KF50BD-TR	KF50BDT-TR	5 V
	KF80BDT-TR	8 V

## 8 Revision history

Table 11. Document revision history

Date	Revision	Changes
06-Jun-2007	9	Order codes updated.
14-Dec-2007	10	Modified: <a href="#">Table 10</a> .
21-Feb-2008	11	Modified: <a href="#">Table 10 on page 18</a> .

**Please Read Carefully:**

Information in this document is provided solely in connection with ST products. STMicroelectronics NV and its subsidiaries ("ST") reserve the right to make changes, corrections, modifications or improvements, to this document, and the products and services described herein at any time, without notice.

All ST products are sold pursuant to ST's terms and conditions of sale.

Purchasers are solely responsible for the choice, selection and use of the ST products and services described herein, and ST assumes no liability whatsoever relating to the choice, selection or use of the ST products and services described herein.

No license, express or implied, by estoppel or otherwise, to any intellectual property rights is granted under this document. If any part of this document refers to any third party products or services it shall not be deemed a license grant by ST for the use of such third party products or services, or any intellectual property contained therein or considered as a warranty covering the use in any manner whatsoever of such third party products or services or any intellectual property contained therein.

**UNLESS OTHERWISE SET FORTH IN ST'S TERMS AND CONDITIONS OF SALE ST DISCLAIMS ANY EXPRESS OR IMPLIED WARRANTY WITH RESPECT TO THE USE AND/OR SALE OF ST PRODUCTS INCLUDING WITHOUT LIMITATION IMPLIED WARRANTIES OF MERCHANTABILITY, FITNESS FOR A PARTICULAR PURPOSE (AND THEIR EQUIVALENTS UNDER THE LAWS OF ANY JURISDICTION), OR INFRINGEMENT OF ANY PATENT, COPYRIGHT OR OTHER INTELLECTUAL PROPERTY RIGHT.**

**UNLESS EXPRESSLY APPROVED IN WRITING BY AN AUTHORIZED REPRESENTATIVE OF ST, ST PRODUCTS ARE NOT DESIGNED, AUTHORIZED OR WARRANTED FOR USE IN MILITARY, AIR CRAFT, SPACE, LIFE SAVING, OR LIFE SUSTAINING APPLICATIONS, NOR IN PRODUCTS OR SYSTEMS, WHERE FAILURE OR MALFUNCTION MAY RESULT IN PERSONAL INJURY, DEATH, OR SEVERE PROPERTY OR ENVIRONMENTAL DAMAGE.**

Resale of ST products with provisions different from the statements and/or technical features set forth in this document shall immediately void any warranty granted by ST for the ST product or service described herein and shall not create or extend in any manner whatsoever, any liability of ST.

ST and the ST logo are trademarks or registered trademarks of ST in various countries.

Information in this document supersedes and replaces all information previously supplied.

The ST logo is a registered trademark of STMicroelectronics. All other names are the property of their respective owners.

© 2008 STMicroelectronics - All rights reserved

STMicroelectronics group of companies

Australia - Belgium - Brazil - Canada - China - Czech Republic - Finland - France - Germany - Hong Kong - India - Israel - Italy - Japan - Malaysia - Malta - Morocco - Singapore - Spain - Sweden - Switzerland - United Kingdom - United States of America

[www.st.com](http://www.st.com)