

# Board Level Heat Sinks

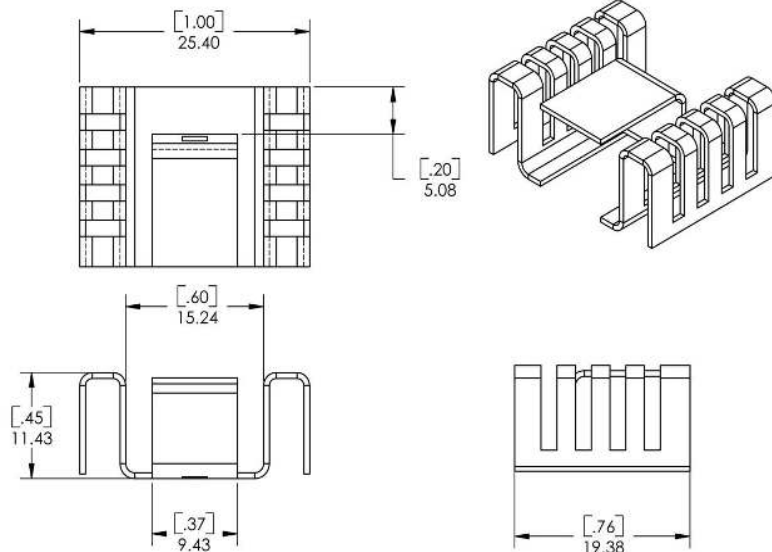

ThermaFlo

**P/N: 834000T00000 & 8340TRT00000**

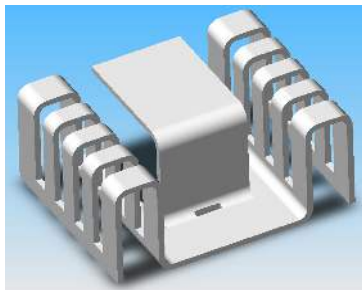

## PRODUCT SPECIFICATIONS

- Devices: D2 PAK, TO-263
- Size: 19.4 x 25.4 x 11.4 mm
- Material: Copper, 0.6 mm Thick
- Type: Stamped
- PCB Mounting: Surface Mount Technology
- Finish: Tin Plate
- Package: Bulk or Tape & Reel

## FEATURES & BENEFITS

- No Hardware Device Attachment
- Direct SMT Contact to PCB
- Solderable Legs
- RoHS Compliant



## CUSTOMIZED HEATSINKS

- Specialized Body Configurations
- Contact Applications Engineering

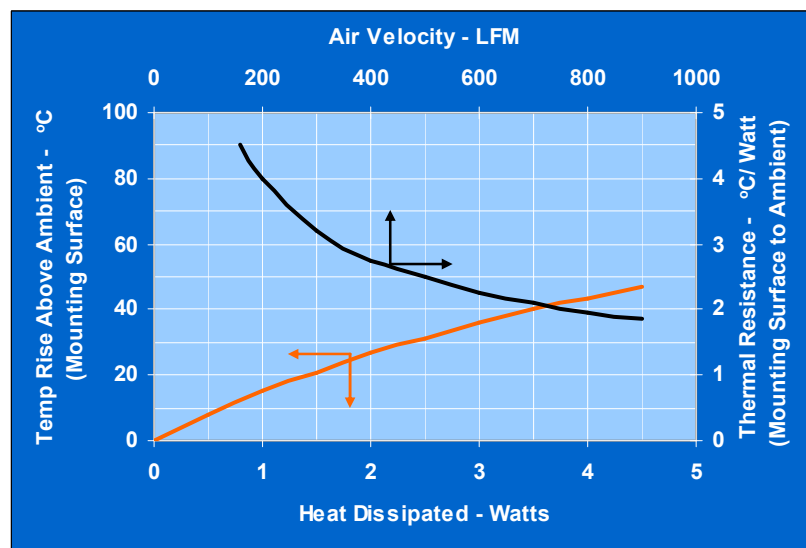

**D2 PAK, TO-263**

Part Number	Packaging	Notes
834000T00000	Bulk	
8340TRT00000	Tape & Reel	Contact Factory for Tape and Reel Specs

## COMAIR ROTRON, INC

8929 Terman Court, San Diego, CA 92121

Ph (858) 348-6200 Fax (858) 566-4577

E-mail: sales@comairrotron.com,

Web: www.comairrotron.com