

REVISIONS					
P.	LTM	DESCRIPTION	DATE	DWN	APVD
A5		Released as per ECR-07-030424	17.12.07	SP	TS
A6		ECR-16-016780	26SEP2017	GR	MKO
A7		REVISED PER ECR-17-014011	28MAR2018	GA	MKO
A8		ECR-21-123577	21MAR2022	RK	JB

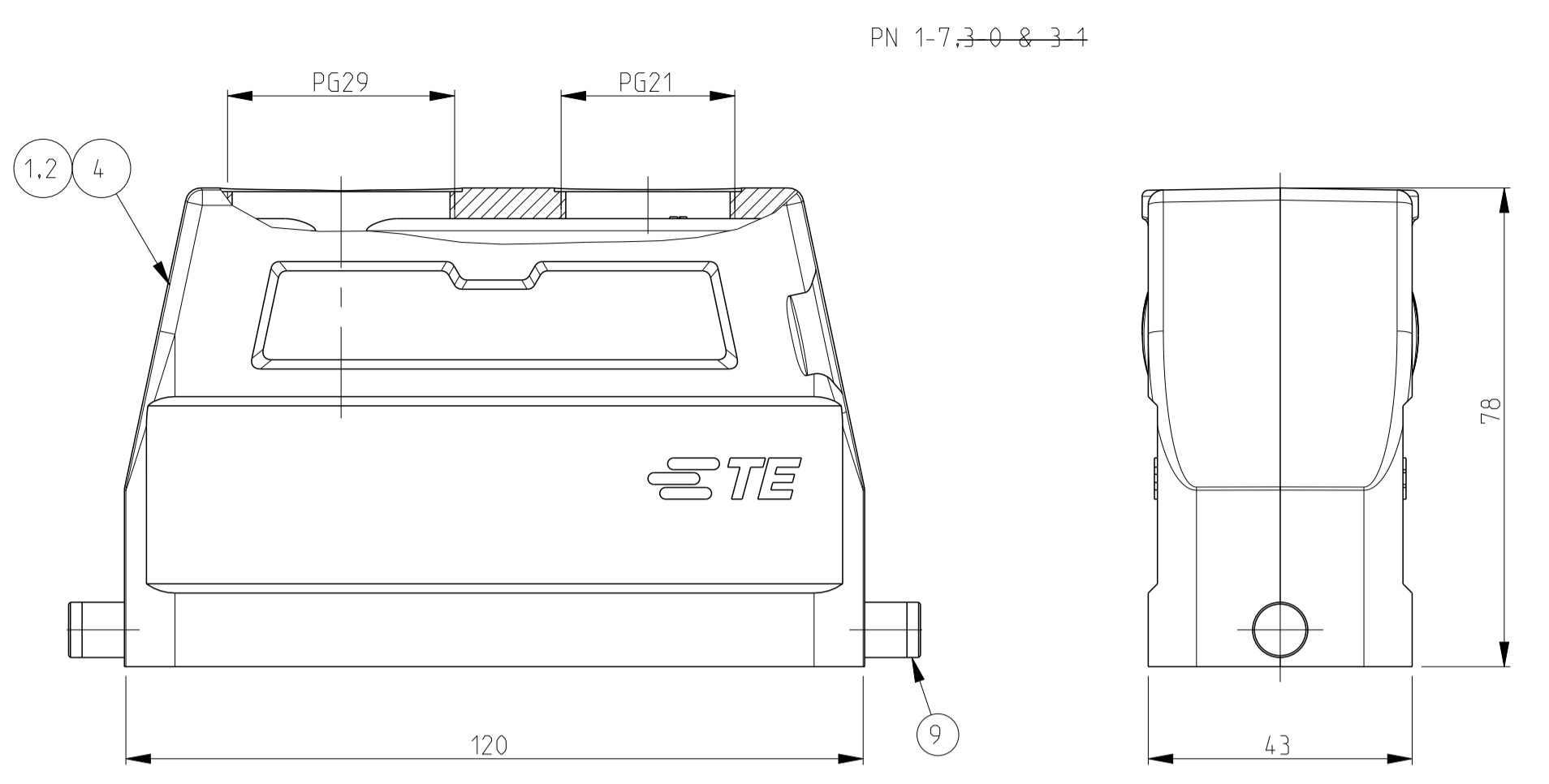

- NOTES:
- Material:Housing:Aluminium Diecasting Alloy
 - Surface:Varnish grey
 - Varnish on the inside not necessary
 - Packaging Quantity 5 Pieces in a box

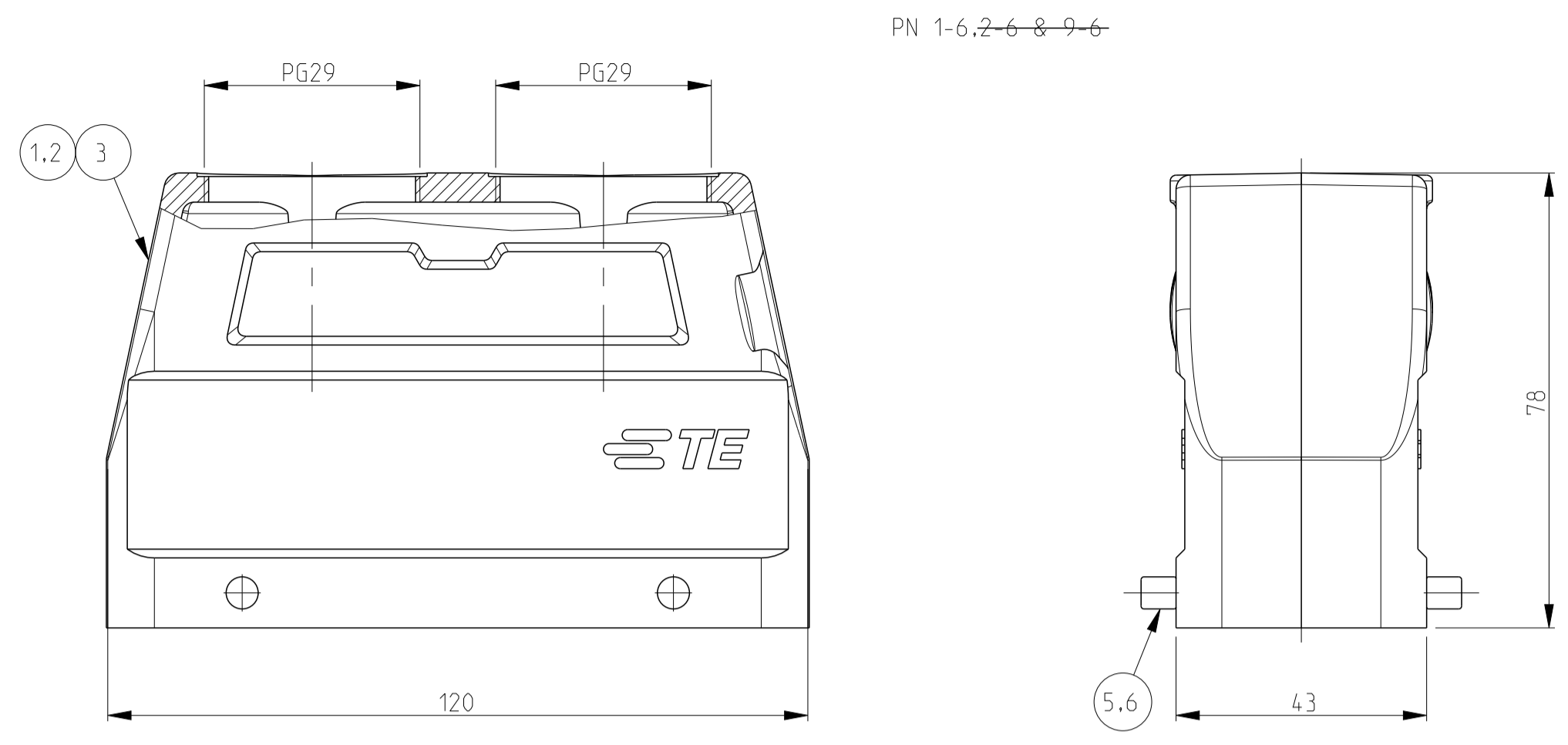
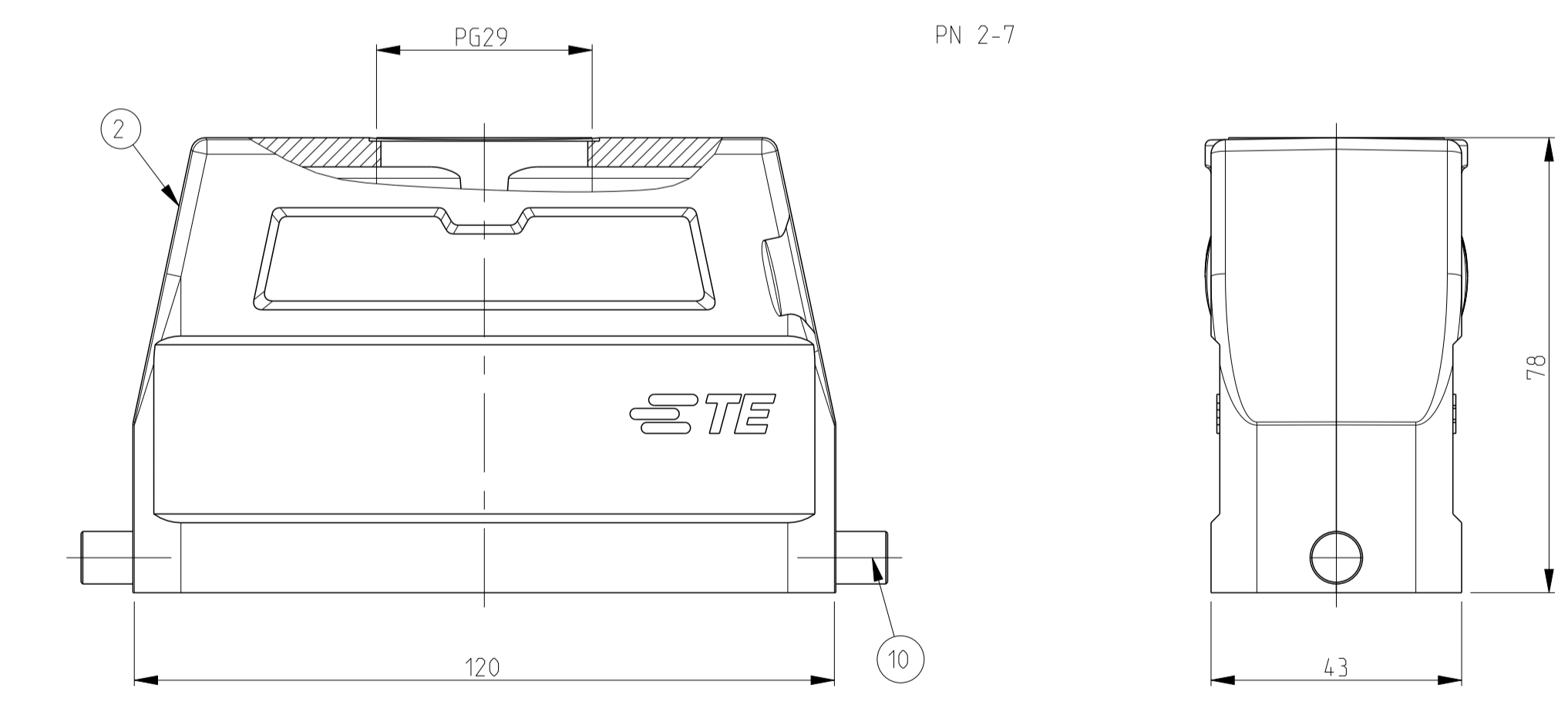
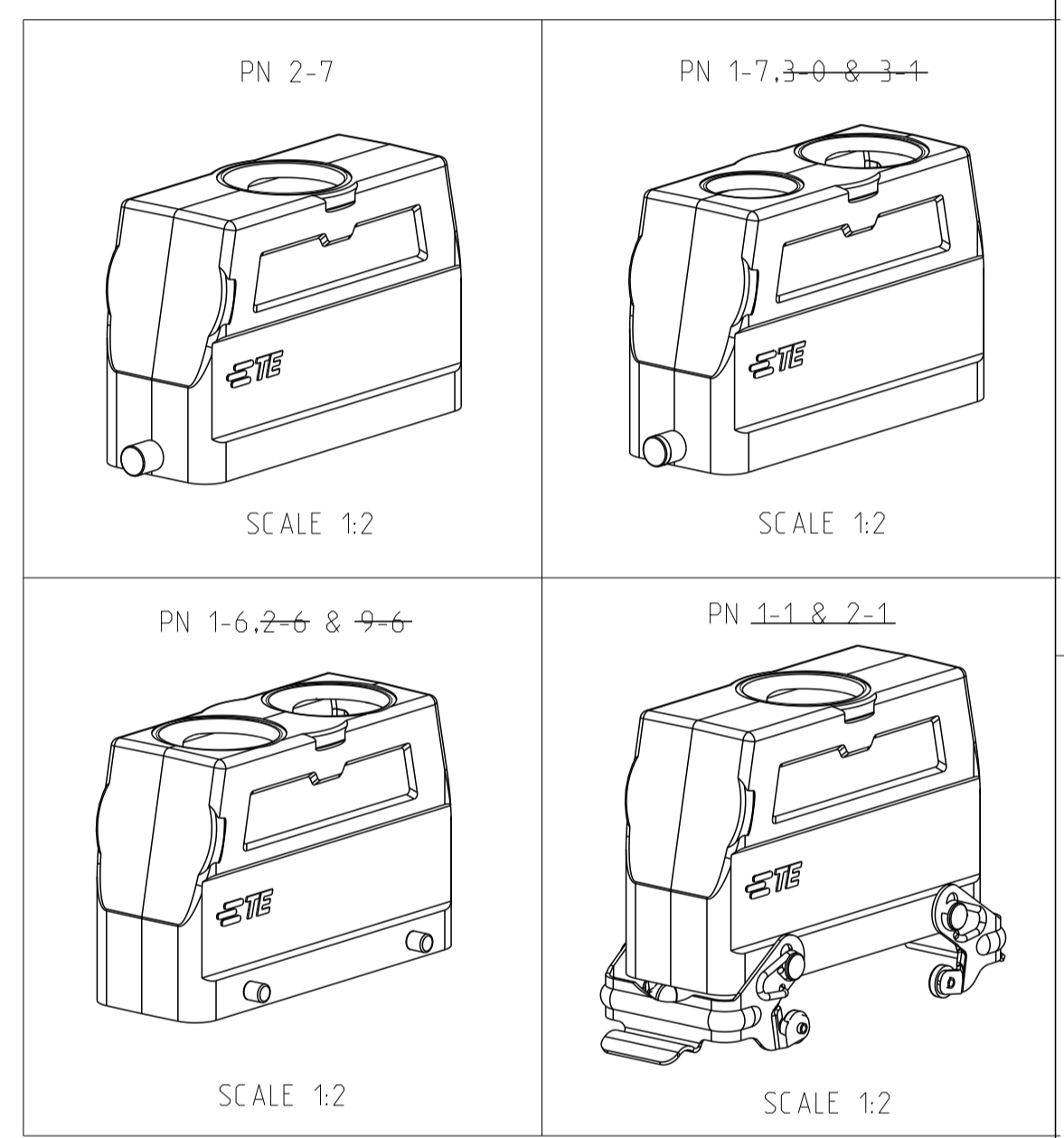
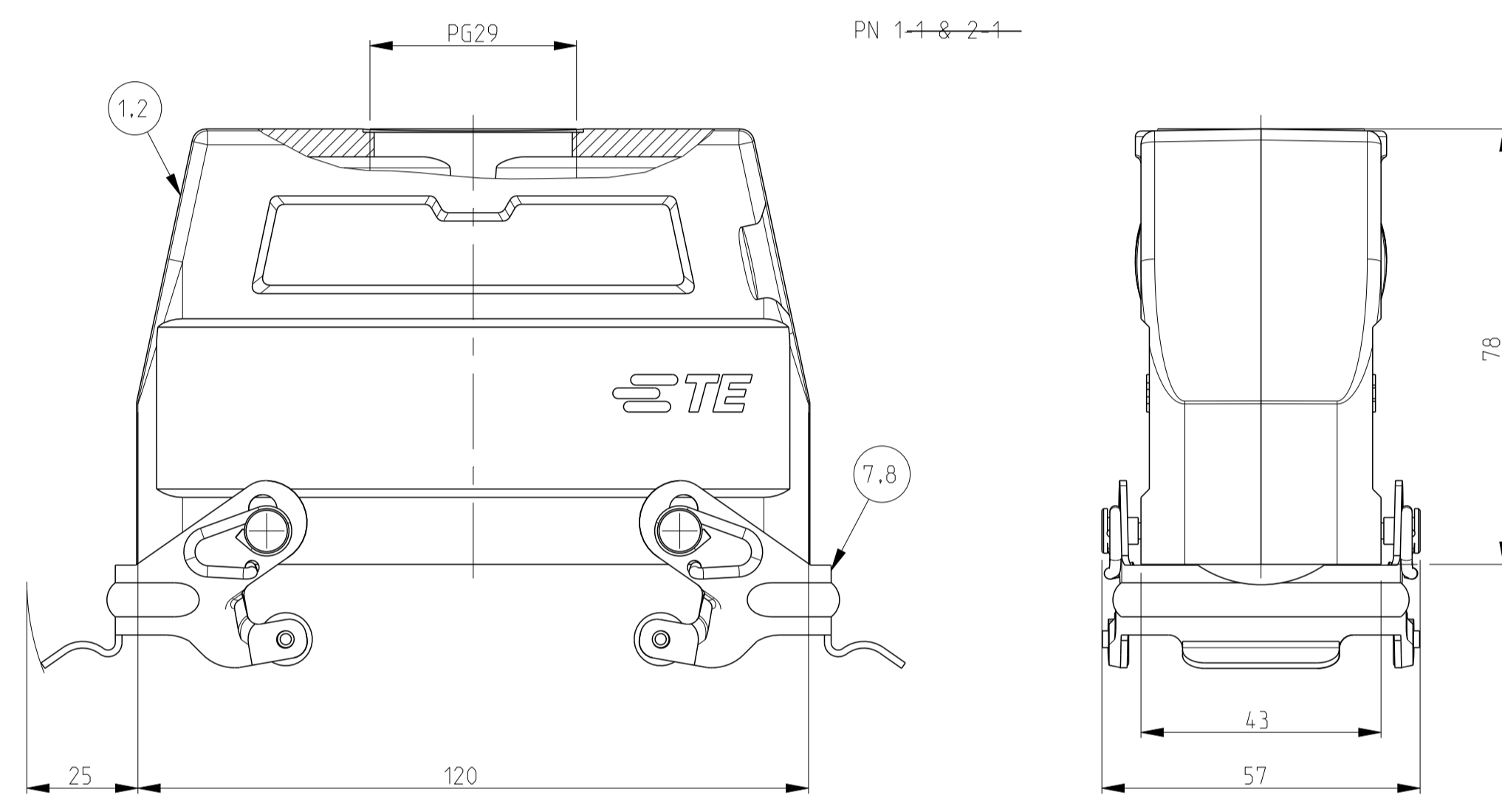

QTY	DESCRIPTION	MATERIAL	SURFACE	COLOR	ITEM NO	REMARKS
2	LB-Side clip	Stainless steel	-		10	
2	LB-Side clip	Steel	Zinc plated	Blue	9	
2	VS-Locking clip	Stainless steel	-		8	
2	VS-Locking clip	Steel	Zinc plated	Blue	7	
4	VS-Clip bolt	Stainless steel	-		6	
4	VS-Clip bolt	Steel	Zinc plated	Blue	5	
1	Hood HD.64.Pg.1.21+1.29	Aluminium	-	Grey	4	
1	Hood HD.64.Pg.1.29	Aluminium	-	Grey	3	
1	Hood HD.64.Pg.1.29	Aluminium	Aluminium oxide	Black	2	
1	Hood HD.64.Pg.1.29	Aluminium	-	Grey	1	

ORDERING TEXT

HD.64.STO.1.29.G
 HD-K.64.STO.1.29.G
 HD.64.STO.VS.1.29.G
 HD-K.64.STO.VS.1.29.G
 HD.64.STO-GR.1.29.G
 HD-K.64.STO-GR.1.29.G
 HD.64.STO-GR.2.29.G-SO
 HD.64.STO-GR.1.21.G+1.29.G-SO
 HD.64.STO.2.29.G-SO

THIS DRAWING IS A CONTROLLED DOCUMENT. DWN Schneider 08.12.1998
 CHK Schneider 08.12.1998

STE TE Connectivity

NAME: Hood HD.64.STO.1.29.G

PRODUCT SPEC: A1 00779 C=1103344

SCALE: 1:1 SHEET 1 OF 1 REV: A8