

MATERIALS & FINISHES

- INSULATORS
  - THERMOPLASTIC PER MIL-M-24519
- CONTACT MATERIAL
  - SOCKET - COPPER ALLOY PER MIL-DTL-32139
- CONTACT FINISH
  - GOLD PLATE PER ASTM B488, TYPE II (HARD GOLD), CODE C, CLASS 1.27
- WIRE - STANDARD
  - 32 AWG, 7 STRAND, TYPE ET PER NEMA HP3
- SHELLS
  - BRASS ALLOY 360
- SHELL FINISH
  - ELECTROLESS NICKEL PER SAE-AMS-2404

|          |            |     |       |          |     |
|----------|------------|-----|-------|----------|-----|
| PART NO. | A79153-001 | REV | ECO   | DATE     | APP |
|          |            | C   | 99177 | 01-02-13 | TLM |

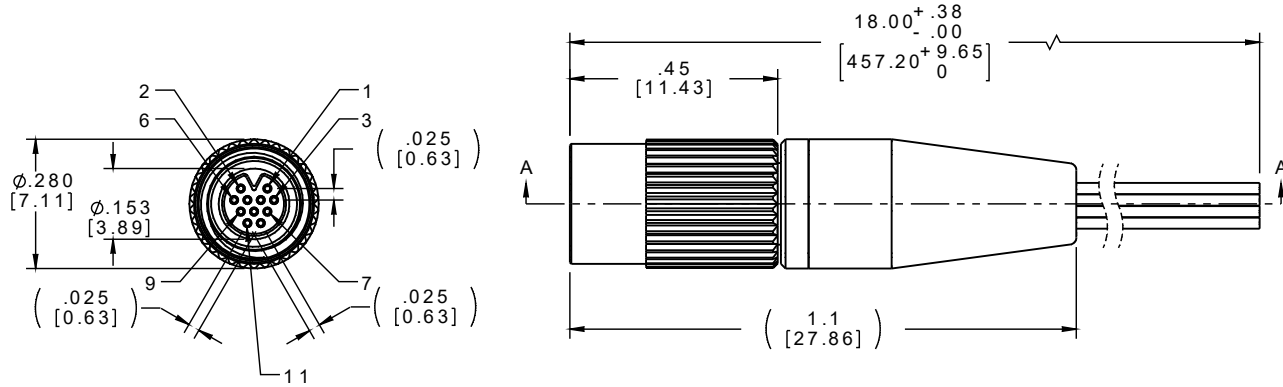

| SOCKET # | COLOR  |
|----------|--------|
| 1, 11    | BLACK  |
| 2        | BROWN  |
| 3        | RED    |
| 4        | ORANGE |
| 5        | YELLOW |
| 6        | GREEN  |
| 7        | BLUE   |
| 8        | VIOLET |
| 9        | GRAY   |
| 10       | WHITE  |

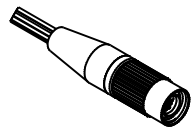

ACTUAL SIZE EXCLUDING WIRE LENGTH

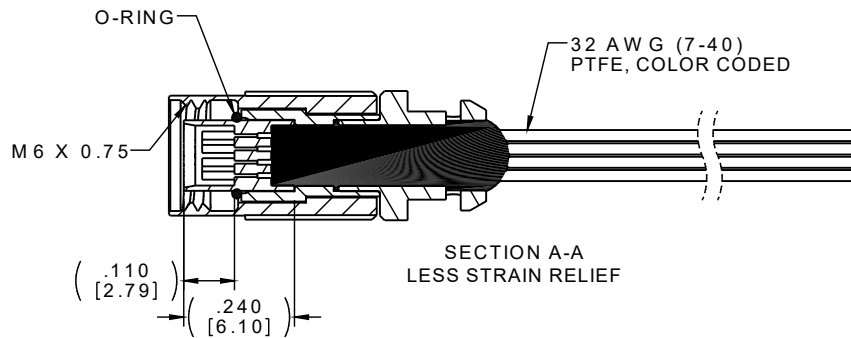

INTERNAL USE ONLY  
USE MFG LOADING  
PROCEDURE NC-115

NOTE:

DIMENSIONS IN [ ] ARE IN MILLIMETERS UNLESS OTHERWISE NOTED AND ARE FOR REFERENCE ONLY

|                      |                        |  |               |  |                    |            |
|----------------------|------------------------|--|---------------|--|--------------------|------------|
| MNS<br>SONS<br>SLDWS | THIRD ANGLE            | THIS DRAWING CONTAINS CONFIDENTIAL AND PROPRIETARY INFORMATION WHICH IS THE PROPERTY OF OMNETICS CONNECTOR CORP. THIS DOCUMENT MAY NOT, IN WHOLE OR IN PART, BE DUPLICATED, OR DISCLOSED FOR ANY PURPOSE, WITHOUT WRITTEN PERMISSION FROM OMNETICS CONNECTOR CORP. |               | <b>OMNETICS</b><br>CONNECTOR CORPORATION<br>7260 COMMERCE CIRCLE EAST<br>MINNEAPOLIS, MN 55432<br>WWW.OMNETICS.COM | CAGE CODE 61873    |            |
|                      | -TOLERANCES-           | DFTM. JPF  | DATE 03-23-09 |  | DWG NO. A79153-001 |            |
|                      | UNLESS OTHERWISE NOTED | CHK'D.   | DATE          |  | SHEET 1 OF 1       |            |
|                      | DIMENSIONS IN INCHES   | APP'D.   | DATE          |  | REV C              | SCALE: 3:1 |

TITLE: (11) SOCKET NANO  
CIRCULAR CONNECTOR  
W/ METAL SHELL