

NOTES:

1. MATERIALS AND FINISHES:

- BODY, R. RING, BODY REAR AND HEX NUTS - BRASS, NICKEL PLATING.
- CONTACTS - BERYLLIUM COPPER, GOLD PLATING.
- CRIMP FERRULE - ANNEALED COPPER, NICKEL PLATING.
- INSULATOR - PTFE
- O-RING - SILICONE RUBBER.
- GASKET - SILICONE RUBBER PER ZZ-R-765.
- LOCK WASHER - STAINLESS STEEL.

2. ELECTRICAL:

- A. IMPEDANCE: 50 OHM.
- B. FREQUENCY RANGE = DC TO 2.0 GHz

3. MECHANICAL:

- A. CONNECTOR IS IP-67 COMPLIANT.
- B. INTERFACE MEETS THE REQUIREMENTS OF MIL-STD-348, BNC SERIES

4. CABLE ASSEMBLY INSTRUCTIONS:

- A. TRIM CABLE AS SHOWN
- B. SLIDE FERRULE & BACKNUT ONTO CABLE
- C. CRIMP FERRULE USING A .128 HEX DIE
- D. CRIMP OR SOLDER BULLET CONTACT TO CABLE CENTER CONDUCTOR
INSERT CABLE WITH BULLET CONTACT INTO BODY
- E. APPLY THREAD LOCKING ADHESIVE ON THE THREADS OF THE BACK NUT
- F. TORQUE BACK NUT DOWN TO 15 IN-LB

5. PACKAGING:

- A. QUANTITY: SINGLE PACK
- B. MARKING: BAG TO BE MARKED
"AMPHENOL, 31-6332, AND DATE CODE"

THIRD ANGLE PROJ.

REVISIONS

REV	DESCRIPTION	DATE	ECO	APPR
A	RELEASED TO MFG	1/5/09	47386	NMV
B	SEE SHEET 1	22-Oct-09	47845	SH
C	SEE SHEET 1	25-Nov-09		SH
D	SEE SHEET 1	07-22-10	48211	AC
E	GASKET WAS CHANGED	22-Nov-10	48349	SH

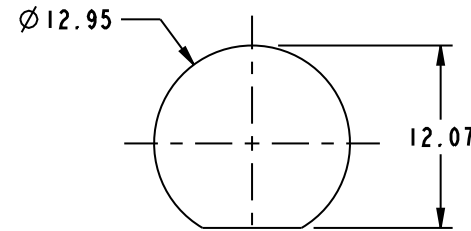

SCALE 2.000
RECOMENDED MOUNTING HOLE DIMENSIONS

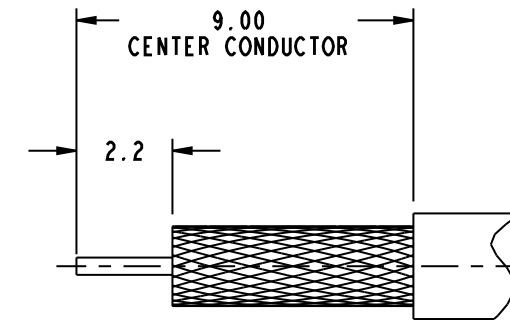

RECOMMENDED CABLE STRIPPING DIMENSIONS

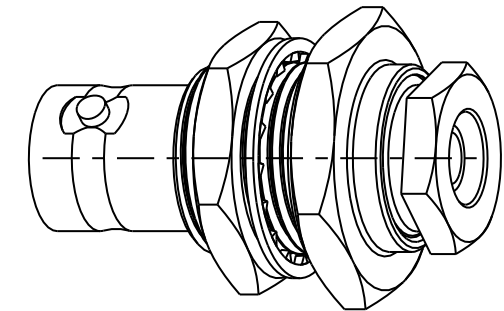

SCALE 2.000

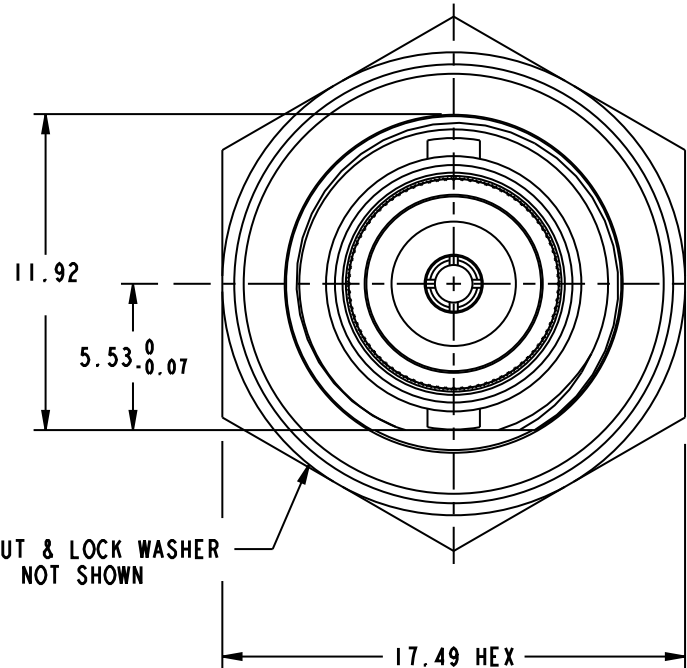

HEX NUT & LOCK WASHER NOT SHOWN

INTERFACE PER MIL-STD-348A SERIES: BNC, JACK

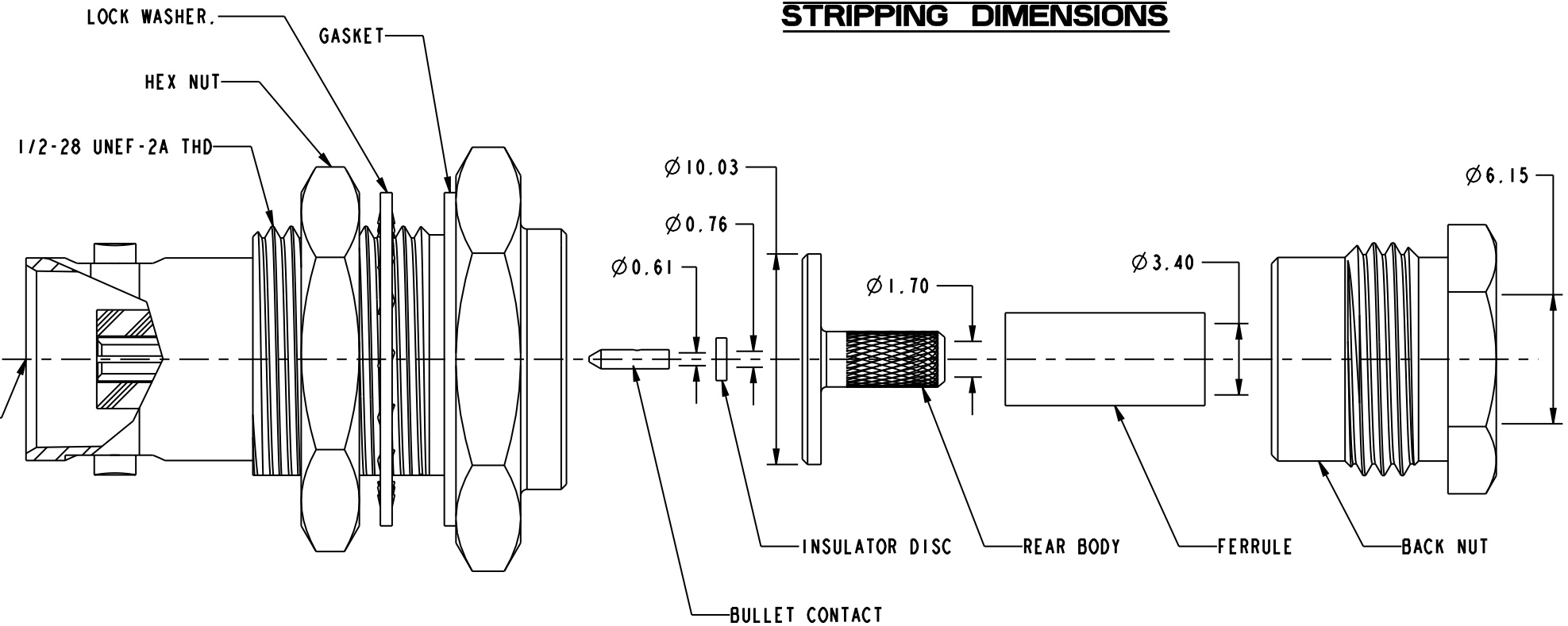

CUSTOMER OUTLINE DRAWING

ALL OTHER SHEETS ARE FOR INTERNAL USE ONLY

UNLESS OTHERWISE SPECIFIED, DIMENSIONS ARE IN METRIC AND TOLERANCES ARE:
 <0.5mm ±0.05mm 0.5 - 6mm ±0.1mm 6 - 30mm ±0.2mm 30 - 120mm ±0.3mm ANGLES ±1°

NOTICE - These drawings, specifications, or other data (1) are, and remain the property of Amphenol corp. (2) must be returned upon request; and (3) are confidential and not to be disclosed to any person other than those to whom they are given by Amphenol Corp. The furnishing of these drawings, specifications, or other data by Amphenol Corp., or to any other person to anyone for any purpose is not to be regarded by implication or otherwise in any manner licensing, granting rights to permitting such holder or any other person to manufacture, use or sell any product, process or design, patented or otherwise, that may in any way be related to or disclosed by said drawings, specifications, or other data.

MATERIAL	DRAWN F. WANG	DATE 22-Nov-10	TITLE BNC, JACK, BULKHEAD IP-67 FOR RD-316		Amphenol RF Danbury CT USA, Tainan, Taiwan, Shenzhen, China www.amphenolrf.com	
REFERENCE EAR # 2718 AND 31-6332	ENGINEER NISCHIT MV	DATE 13-Dec-10				
CONFIGURATION LEVEL: Released	APPROVED SCOTT.H	DATE 22-Nov-10	SCALE: 3.5:1.0	SHEET 2 OF 2	DRAWING NO. 31-6332	
FINISH	CAD FILE 1:/BNC/31-6332		DWG SIZE B	REV E	ITEM NO. 31-6332	
					PART NO. 31-6332	