

Thermofit[®] Molded Parts
 Specification Control Drawing
 Limited Distribution

Part Number : 202D232-X-22
 Description : Boot, Straight, With Lip

NOTES

- All dimensions are in $\frac{\text{inches}}{[\text{millimeters}]}$
- Dimensions appearing in table are as follows:
 a - As Supplied
 b - After Unrestricted Recovery
- Coating is optional. As supplied dimensions appearing in table are for uncoated parts. When coating is added, entry diameters will be reduced by .06 max.

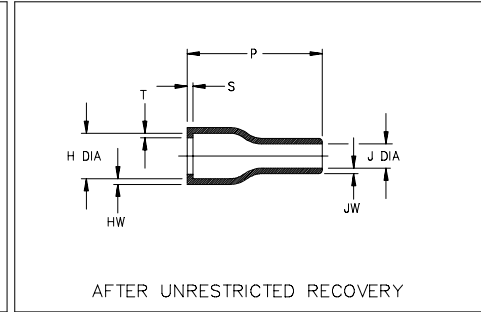
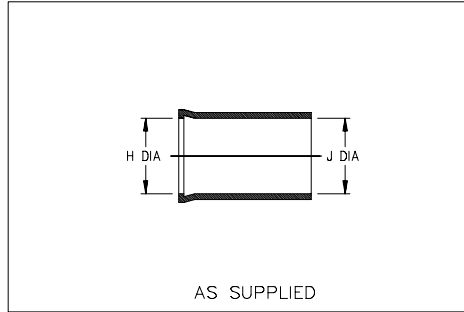

PART NUMBER	H		J		P ±10%	S Ref	T Ref	HW ±20%	JW ±20%
	Min	Max	Min	Max					
	a	b	a	b	b	b	b	b	
202D232-X-22	1.16 [29,5]	.74 [18,8]	1.16 [29,5]	.33 [8,4]	3.50 [88,9]	.12 [3,0]	.04 [1,0]	.07 [1,78]	.045 [1,1]

Raychem

RAYCHEM CORPORATION
 300 CONSTITUTION DRIVE
 MENLO PARK, CALIFORNIA 94025

Revision : A
 Date : 5/3/00

Part Number : 202D232-X-22
 Description : Boot, Straight, With Lip

Thermofit[®] Molded Parts
 Specification Control Drawing
 Limited Distribution

Part Number : 202D232-X-22
 Description : Boot, Straight, With Lip

COMPATABILITY CHART					
MATERIAL DASH NO.	MATERIAL DESCRIPTION	RT SPEC	COATING SLASH NO.	COATING S NO.	COATING DESCRIPTION
-3	Polyolefin, Semi-rigid	RT-301	N/A		

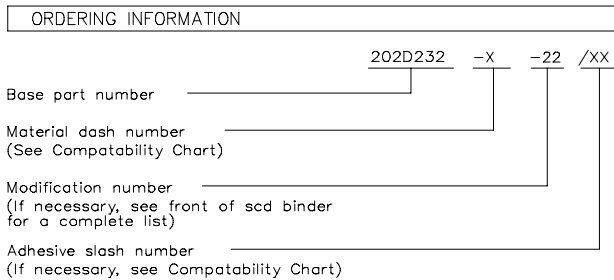

If this document is printed it becomes uncontrolled.
 Check for the latest revision.

THIS DRAWING IS SUBJECT TO CHANGE WITHOUT NOTICE; CONSULT YOUR
 NEAREST FIELD REPRESENTATIVE FOR CURRENT REVISION

Raychem

RAYCHEM CORPORATION
 300 CONSTITUTION DRIVE
 MENLO PARK, CALIFORNIA 94025

Revision : A
 Date : 5/3/00

Part Number : 202D232-X-22
 Description : Boot, Straight, With Lip
 CAD FILE MP00061