

P	LTR	DESCRIPTION	DATE	DWN	APVD
F		REVISED PER ECO-21-006900	13DEC21	RK	MZ

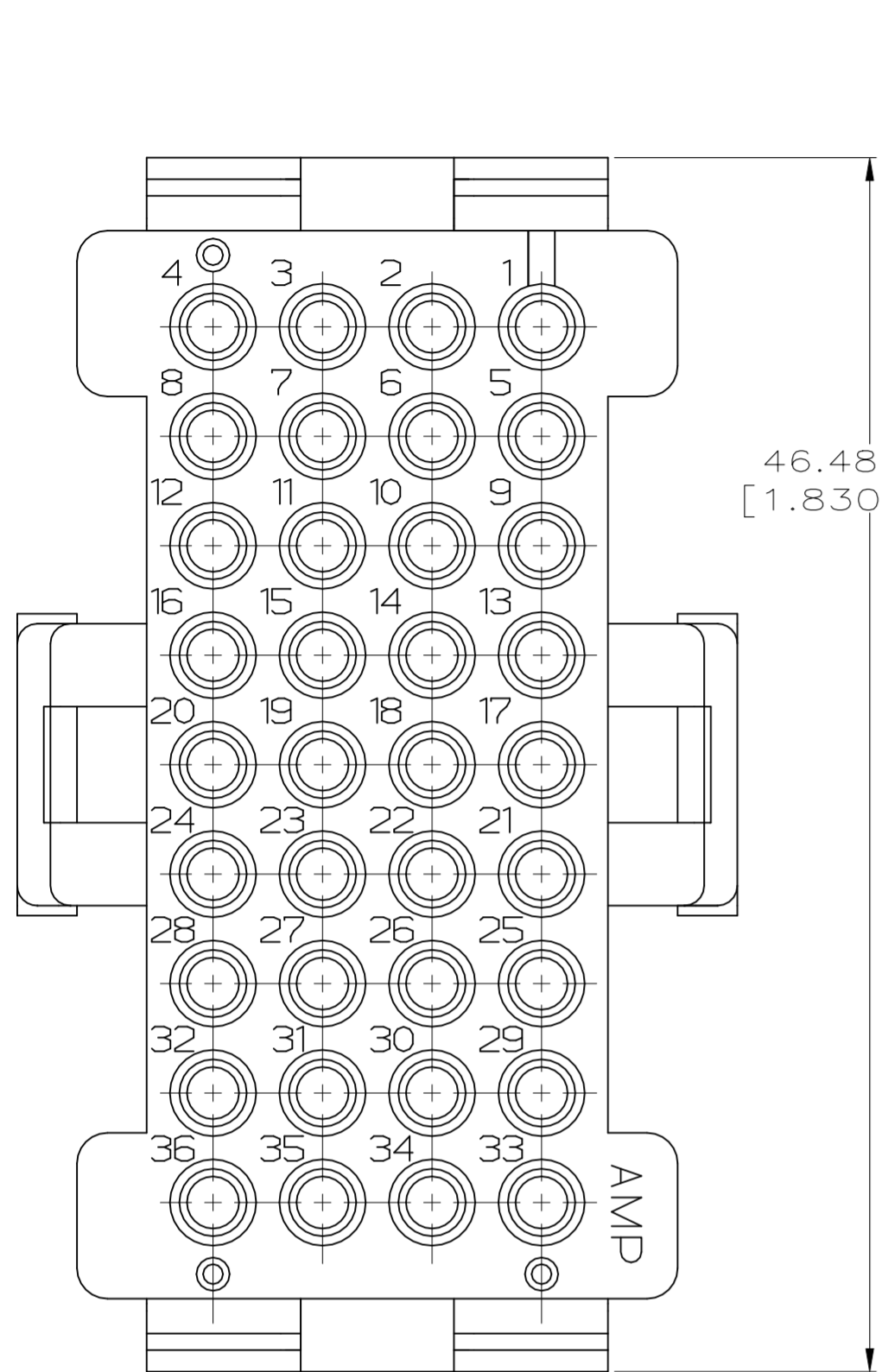

46.48 ± 0.38
[1.830 ± 0.015]

5.46 [.215] REF
14.22 [.560]

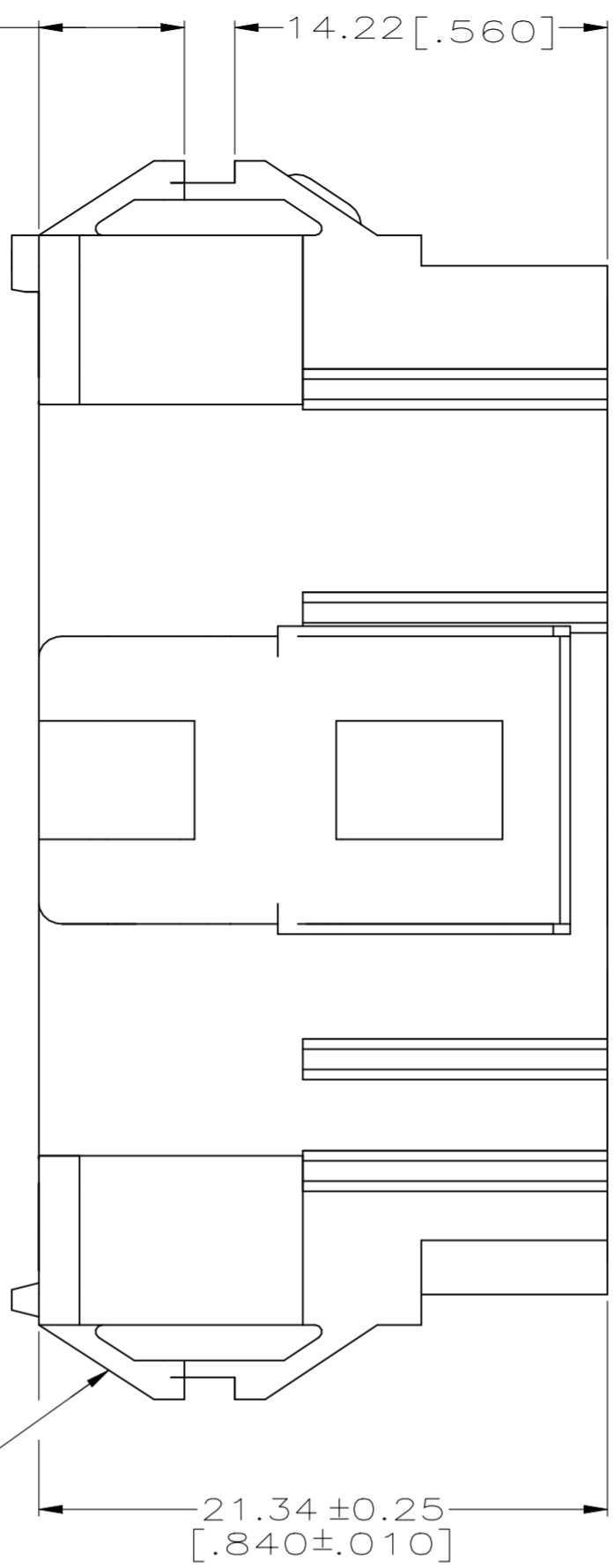

21.34 ± 0.25
[.840 ± 0.010]

40.89
[1.610]

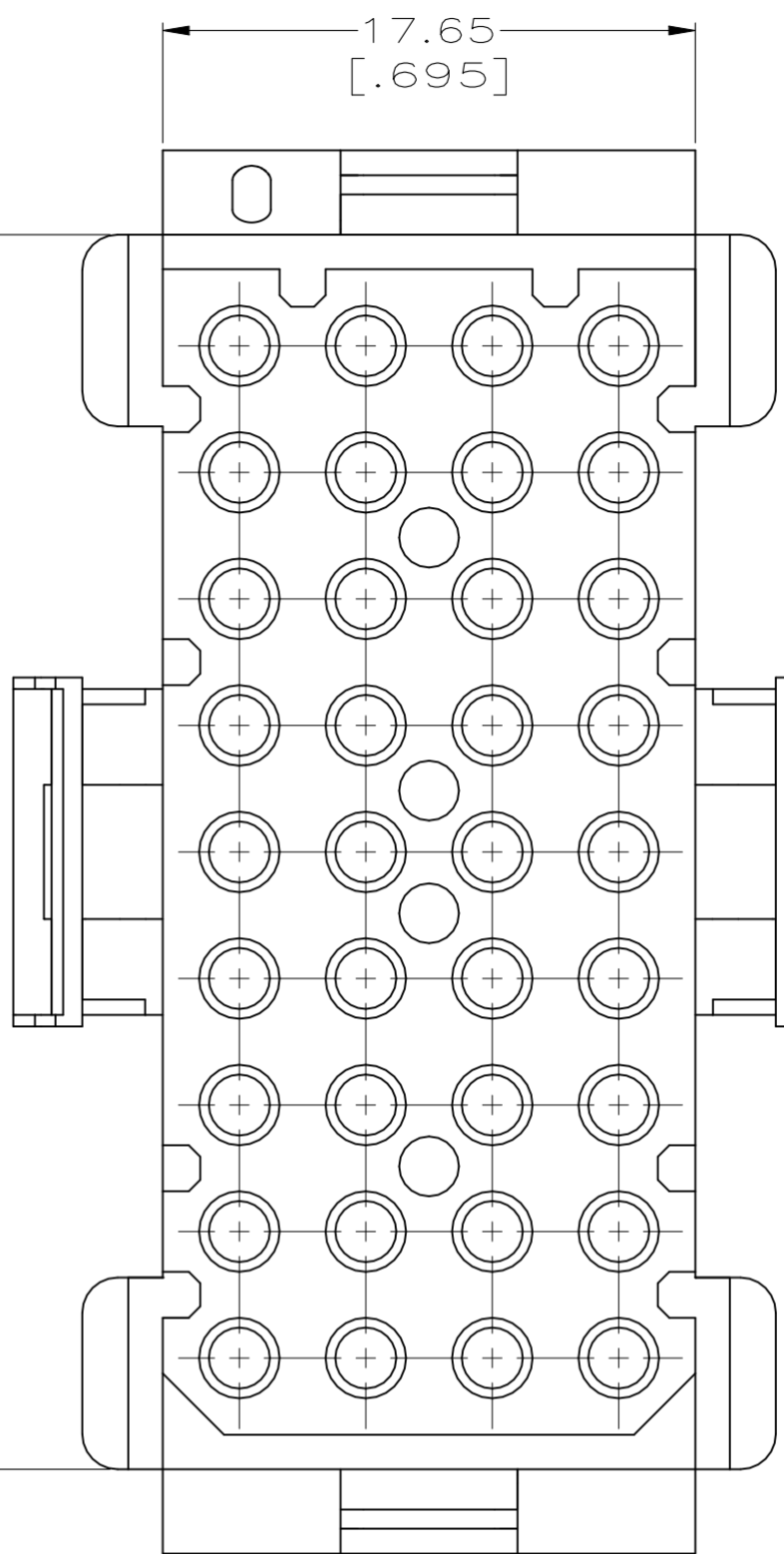

17.65
[.695]

1. MATES WITH HOUSING 640516.
2. UL LOGO AND CSA LOGO TO APPEAR ON EITHER LATCH SURFACE PER AMP SPEC 202-20, I.D. NO. 1-18838-3 AND 1-18839-3. FROST BACKGROUND OPTIONAL.
3. DIMENSIONS IN BRACKETS ARE IN INCHES.
4. NON-FILL PERMITTED UP TO 3.8[.15] FROM EDGE OF LATCH ARM ON THE 0.38[.015] THICK FLANGE, 4 PLC.
5. HOUSING MATERIAL: PA66, BLACK, UL 94 V-0 RATED

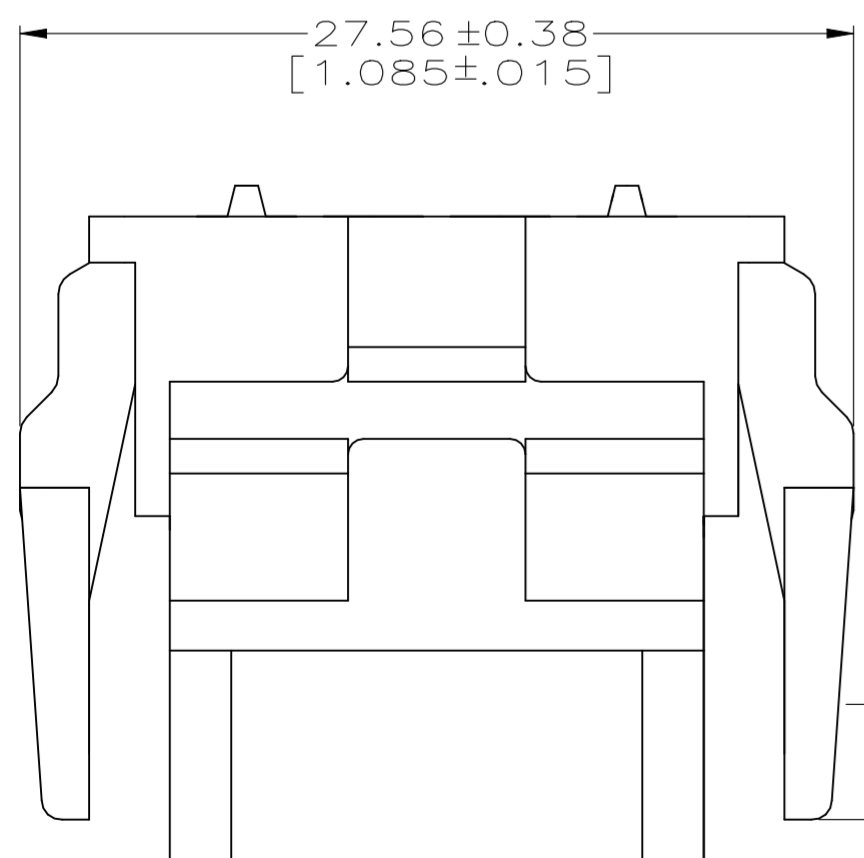

27.56 ± 0.38
[1.085 ± 0.015]

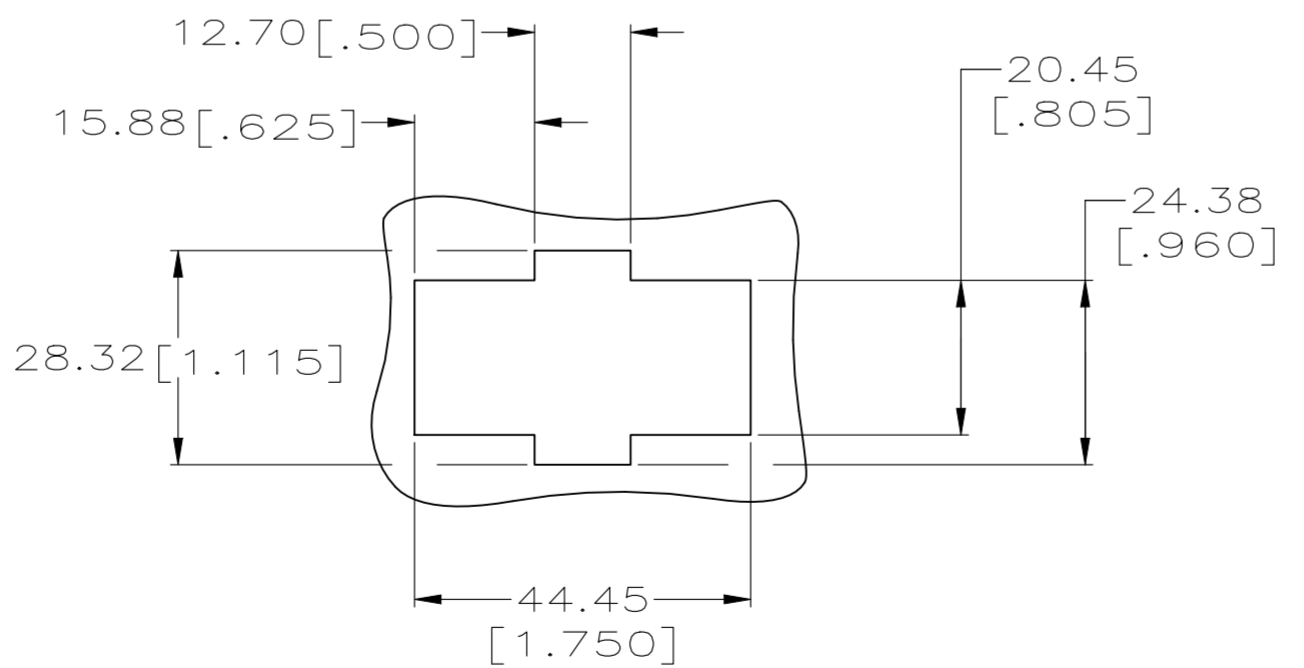

RECOMMENDED CUT OUT FOR 1.73 [.068] MAX THICK PANEL SCALE 1:1

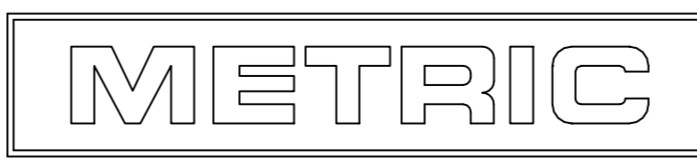

1-640526-0
PART NUMBER

THIS DRAWING IS A CONTROLLED DOCUMENT.		DWN R. VESTAL 12-01-97		
DIMENSIONS: mm [INCHES]		CHK R. SWING 12-01-97		
TOLERANCES UNLESS OTHERWISE SPECIFIED:		APVD A. BEDDICK 12-01-97	NAME HOUSING, PLUG MRII 36 POSITION	
0 PLC ± -		PRODUCT SPEC	SIZE A2	CAGE CODE 00779
1 PLC ± -		APPLICATION SPEC	DRAWING NO C-640526	RESTRICTED TO -
2 PLC ± 0.13 [.005]		WEIGHT	SCALE 4:1	SHEET 1 of 1
3 PLC ± -		MATERIAL	REV F	
4 PLC ± -		FINISH		
ANGLES ± 0° 30'		CUSTOMER DRAWING		