

REVISION		
REV	DESCRIPTION	DATE
B	REVISED PER DCR NUMBER T31568	6/11/03

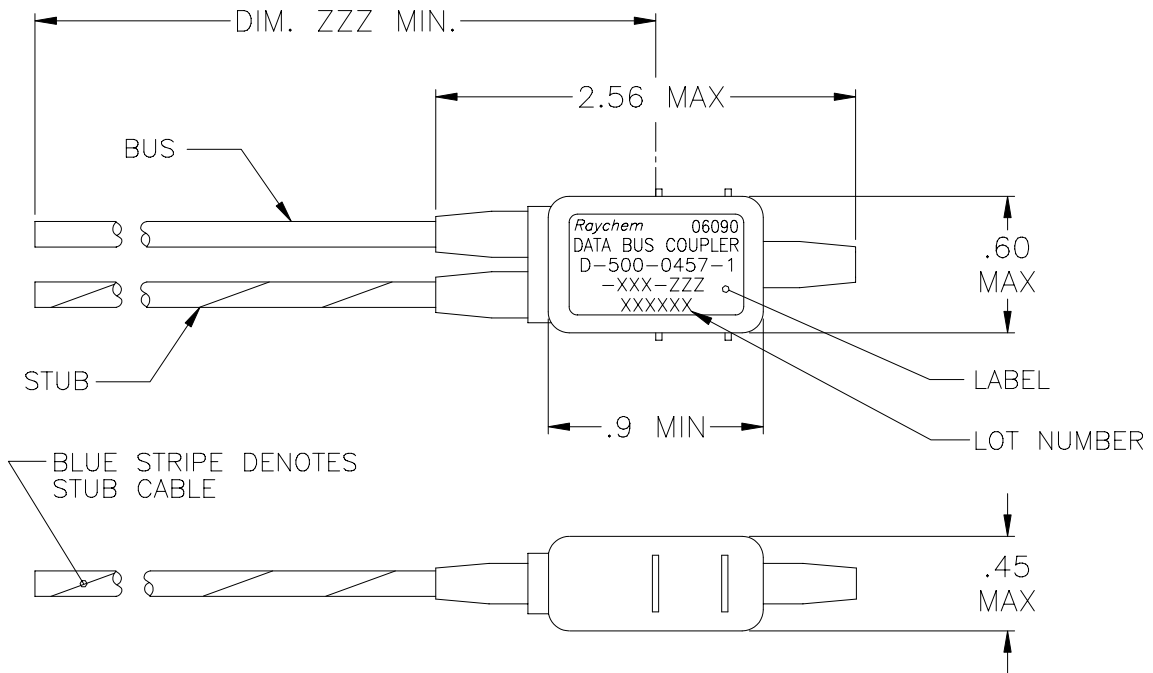

COMPONENT NUMBER	BUS CABLE	STUB CABLE
D-500-0457-1-612-ZZZ	10612-24-9	10612-24-96
D-500-0457-1-613-ZZZ	10613-24-9	10613-24-96
D-500-0457-1-614-ZZZ	10614-24-9	10614-24-96

PART NO. D-500-0457-1-XXX-ZZZ

SCHEMATIC ————

7=TERMINATOR (AS SHOWN)

1=SINGLE STUB ————

LENGTH OF CABLE (INCHES)

CABLE

612=10612 (SINGLE OPTIMIZED BRAID)

613=10613 (DOUBLE OPTIMIZED BRAID)

614=10614 (EMP HARDENED)

If this document is printed it becomes uncontrolled.
Check for the latest revision.

SPECIFICATION CONTROL DRAWING			
UNLESS OTHERWISE SPECIFIED DIMENSIONS ARE INCHES. METRIC DIMENSIONS ARE IN BRACKETS.	DRAWN	DATE	Tyco Electronics 300 CONSTITUTION DRIVE MENLO PARK, CALIFORNIA 94025 USA
	D.PIQUE	95MAY11	
DECIMAL TOLERANCES	MATERIAL	TITLE	
.XXX ± --- [--- mm]		DATABUS MICROCOUPLER, SINGLE STUB, IN-LINE 04 SERIES WITH BUS TERMINATOR	
.XX ± --- [--- mm]			
.X ± --- [--- mm]	FINISH	SIZE	CODE IDENT. NO.
ANGLE TOLERANCE	THIRD ANGLE PROJECTION	A	06090
.X ± ---		DWG. NO.	D-500-0457-1-XXX-ZZZ
WEIGHT SEE NOTES	DO NOT SCALE THIS DRAWING		SHEET 1 OF 2
CAD FILE	T31568A		

1. MATERIAL AND FINISHES:
 - 1.1 INTERNAL COMPONENTS:
 - 1.1.1 -TRANSFORMER TO MIL-PRF-21038 AND MIL-STD-1553B
 - 1.1.2 -RESISTORS, ISOLATION PER MIL-PRF-39007/9, 57.6 OHMS (R1)
 - 1.1.3 -RESISTOR, TERMINATION PER MIL-PRF-39007/9, 76.8 OHMS (R2)
 - 1.2 SHIELDED CASE: ALUMINUM PER ASTM-B618
 - 1.3 SEALED STRAIN RELIEF COVER: MODIFIED CROSS-LINKED ELASTOMER, BLACK, TO RAYCHEM SPECIFICATION RK-6713.
 - 1.4 CABLE TYPE PER RAYCHEM SPECIFICATION 1200 (SEE PART NO. ON SHEET 1).
2. APPLICATION:
 - 2.1 THIS COUPLER IS DESIGNED TO BE INSTALLED INTO A DIGITAL MULTIPLEX ASSEMBLY MEETING THE REQUIREMENTS OF MIL-STD-1553B.
 - 2.2 FOR CABLE SPLICING USE FLEXIBLE SPLICE KIT D-150-0708-5 (NOT SUPPLIED)
 - 2.3 CABLE BEND RADIUS PER SAE-AS50881 STATIC BEND: 5 x CABLE O.D. MIN.
DYNAMIC BEND: 10 x CABLE O.D. MIN.
3. TEMPERATURE:
 - 3.1 OPERATING TEMPERATURE: -65°C TO +150°C
4. PERFORMANCE SPECIFICATIONS:
 - 4.1 TRANSFORMER MEETS THE PERFORMANCE REQUIREMENTS OF MIL-STD-1553B.
 - 4.2 COUPLER MEETS THE PERFORMANCE REQUIREMENTS OF RAYCHEM SPECIFICATION D-6020.
5. WEIGHT:
 - 5.1 MAXIMUM WEIGHT WITHOUT CABLE:

10 GRAMS MAX.

ONE STUB COUPLER SCHEMATIC

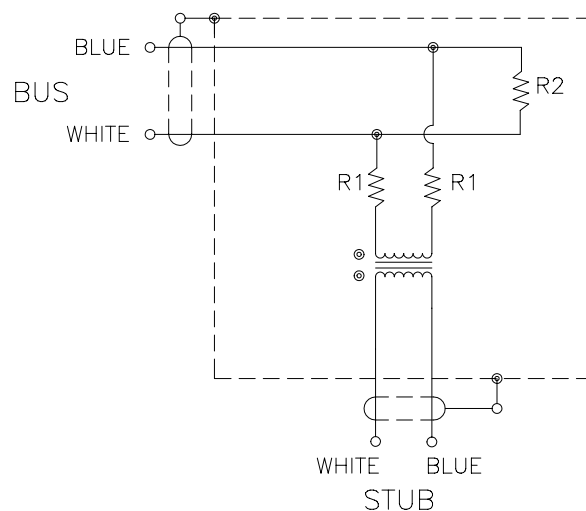

If this document is printed it becomes uncontrolled.
Check for the latest revision.

SPECIFICATION CONTROL DRAWING

DRAWN DCP	DATE 95MAY11	SIZE A	CODE IDENT. NO. 06090	DWG. NO. D-500-0457-1-XXX-ZZZ	REV B
CAD FILE T31568B	tyco Electronics	DO NOT SCALE THIS DRAWING			SHEET 2 OF 2