

TO OUR VALUED CUSTOMERS

I want to express my thanks to you for being interested in our products and for having confidence in Mikroelektronika.

The primary aim of our company is to design and produce high quality electronic products and to constantly improve the performance thereof in order to better suit your needs.

A handwritten signature in white ink, appearing to read 'N. Matic', is positioned on the right side of the page.

Nebojsa Matic
General Manager

Table of Contents

Ready for AVR board Introduction	4	6. USB-UART	18
System Specification	5	7. Port headers	19
Components	6	8. General Purpose Area	20
1. Power supply	8	9. Integrating with the casing	21
6. External Oscillator	9	10. Dimensions	22
4. ATmega16 microcontroller	10		
5. Programming the microcontroller	11		
Programming with mikroBootloader	12		
step 1 - Connecting	12		
step 2 - Connecting	13		
step 3 - Browsing for .hex file	13		
step 4 - Browsing for .hex file	14		
step 5 - uploading .hex file	14		
step 6 - Finish upload	15		
Programing with AVRProg™ programmer	16		

Ready for AVR board Introduction

Ready for AVR Board is the best solution for fast and simple development of various microcontroller applications. It comes with **ATmega16** that is placed in DIP40B socket. It is preprogrammed with UART bootloader, so you don't have to use external programmers to program the microcontroller. Board contains double-row IDC10 headers for all available microcontroller ports. It also contains USB-UART module, prototyping area and a power supply circuit. Board is specially designed to fit into special white plastic casing so you can turn your cool AVR project into a final product.



System Specification



power supply

Via AC/DC connector 7-23V AC
or 9-32V DC



power consumption

50mA in idle state
(when on-board modules are off)



board dimensions

14 x 8,2cm (5.51 x 3.23 inch)



weight

~69g (0.15 lbs)

Components



- AVRProg™ connector 01
- Power LED indicator 02
- 8MHz external oscillator 03
- DIP40A socket 04
- UART comm. LEDs (RX, TX) 05
- FTDI chip 06
- USB UART connector 07
- Power connector 08
- Power screw terminals 09
- IDC10 PORT header 10
- Power regulator 11
- Reset button 12
- ATmega16 microcontroller 13
- Prototyping area 14
- Mounting holes 15

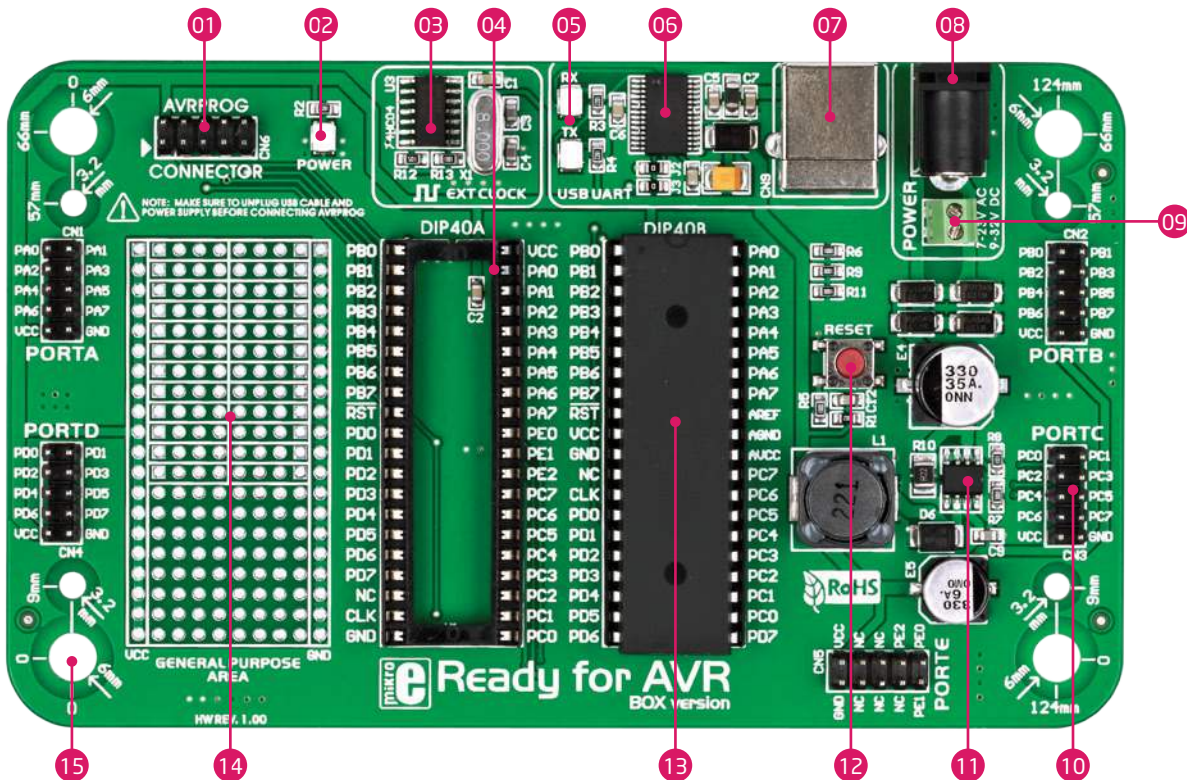

1. Power supply

Ready for AVR board can be powered in two ways: over USB connection, or using external power sources, such as adapters, or laboratory power supplies. USB connection can provide up to 500mA of current, which is more than enough for every on-board module and for operation of the microcontroller. If you decide to use external power supply, you can choose between AC/DC adapter connector or power screw terminals. Voltage and current values must be within **7-23V AC** or **9-32V DC** ranges. Power LED will indicate the presence of current. Use only one method for powering the board.

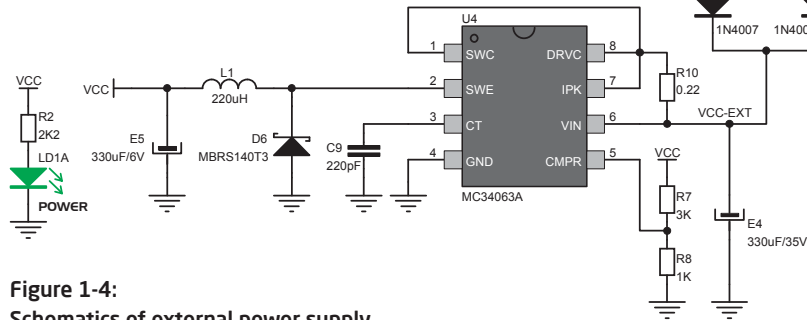

Figure 1-4:
Schematics of external power supply

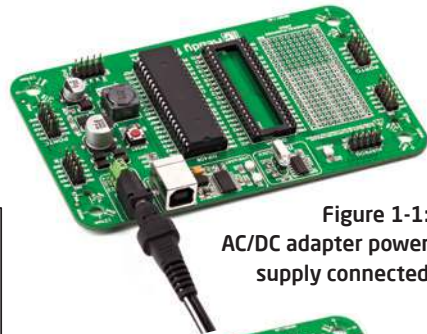
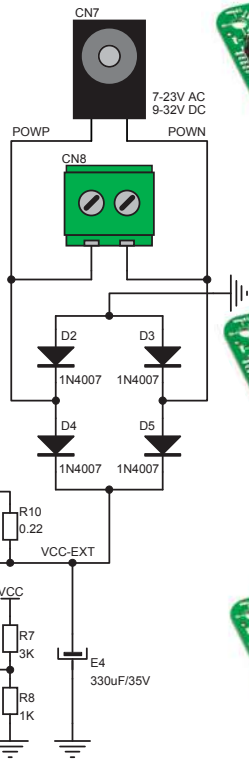

Figure 1-1:
AC/DC adapter power supply connected

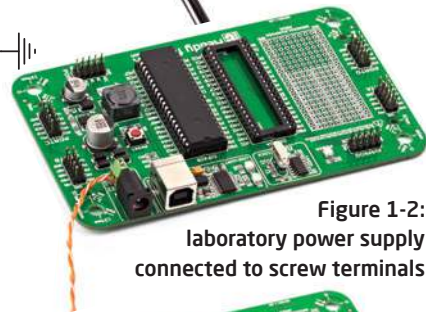

Figure 1-2:
laboratory power supply connected to screw terminals

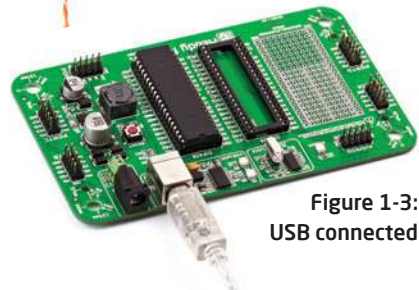

Figure 1-3:
USB connected

6. External Oscillator

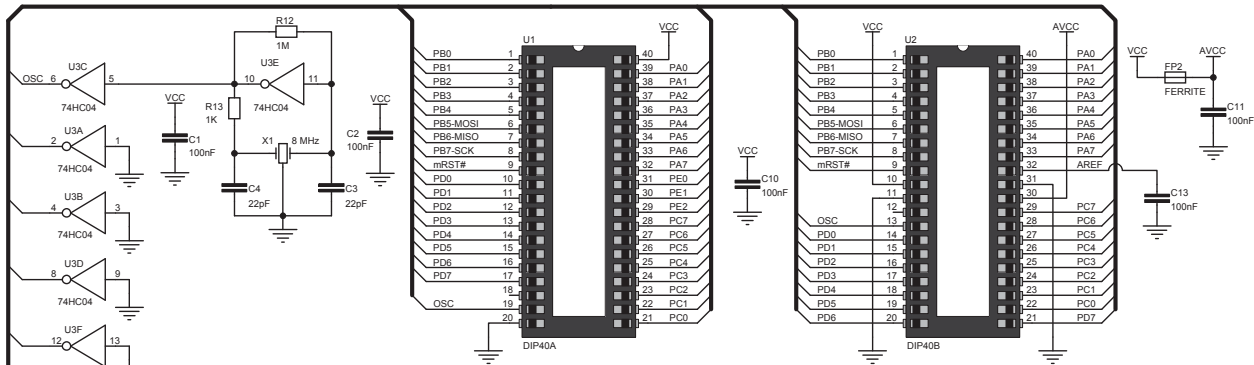
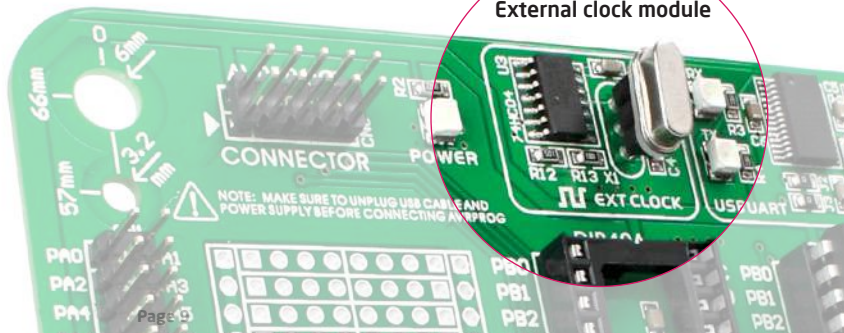

Figure 6-1:
External Oscillator schematics

Board contains 8MHz external crystal oscillator which delivers the clock necessary for the operation of microcontroller. Raw clock signal from the crystal is sinusoidal, so additional 74HC04 is provided which filters it to create square signal necessary for stable operation.

Figure 6-2:
External clock module



4. ATmega16 microcontroller

Ready for AVR development system comes with the **ATmega16** microcontroller. Having lots of MIPS power, flash and RAM, and rich set integrated modules, ATmega16 is ideal choice for both beginners and professionals.

Key microcontroller features

- Up to **16 MIPS** Operation;
- 8-bit architecture;
- 16 KB of Flash program memory;
- 1 KB of internal SRAM memory;
- 512 Bytes of EEPROM
- 32 I/O pins;
- UART, SPI, ADC; etc.
- JTAG DEBUGGING interface

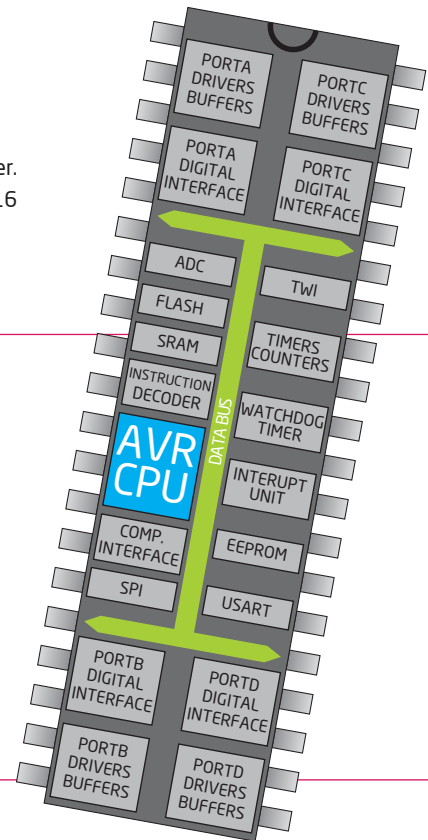

5. Programming the microcontroller

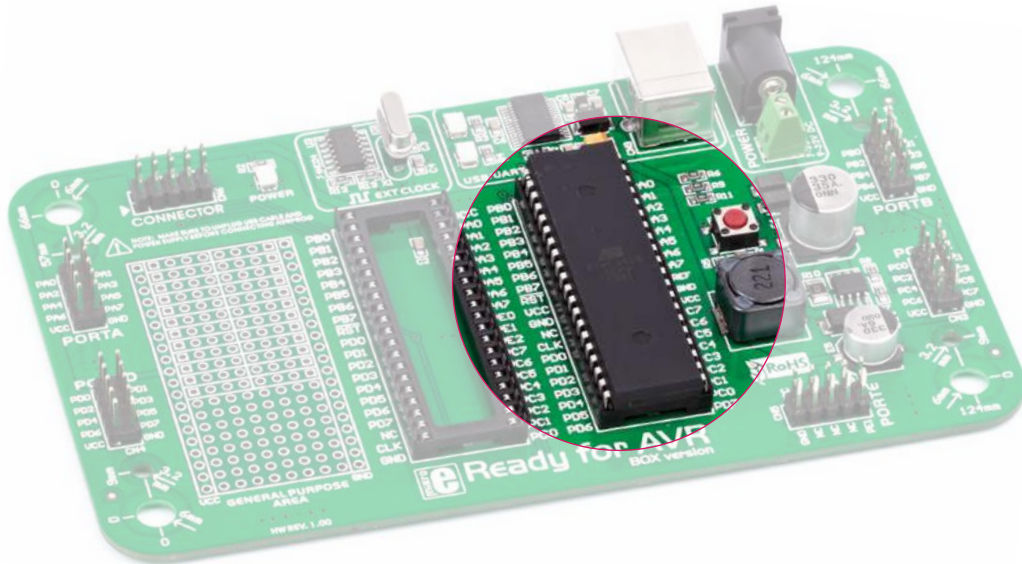

Figure 5-1: ATmega16

The microcontroller can be programmed in two ways:

- 01 Over USB-UART mikroBootloader
- 02 Using JTAG external programmer

Programming with mikroBootloader

You can program the microcontroller with bootloader which is preprogrammed into the device by default. To transfer .hex file from a PC to MCU you need bootloader software (**mikroBootloader USB HID**) which can be downloaded from:



http://www.mikroe.com/eng/downloads/get/1652/mikrobootloader_atmega16_v100.zip

After software is downloaded unzip it to desired location and start mikroBootloader USB HID software.

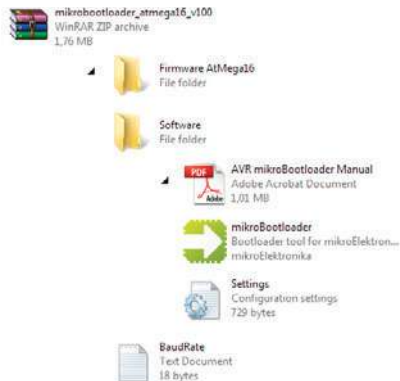

step 1 - Connecting

- 01 Start mikroBootloader
- 02 Click the **Change Settings** button.
- 03 In Setup window, select appropriate **COM port**. Click OK.



Figure 5-2: UART mikroBootloader

note

This version of mikroBootloader is for AVR microcontrollers only.

step 2 - Connecting



Figure 5-3: Browse for HEX

- 01 Press **reset button** on Ready board.
- 02 Click **Connect button** within 5s, otherwise existing microcontroller program will execute.

step 3 - Browsing for .hex file



Figure 5-4: Browse for HEX

- 01 Click on **Browse for HEX button**.

step 4 - Browsing for .hex file

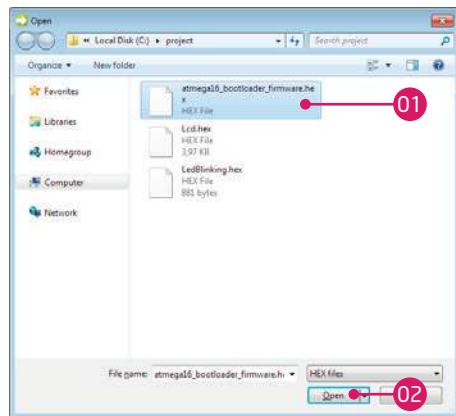

Figure 5-5: Locating and Selecting .hex file

- 01 Select .hex file via open dialog window.
- 02 Click on **Open button**.

step 5 - uploading .hex file



Figure 5-6: Begin uploading

- 01 To start .hex file uploading click on **Begin uploading button**.

step 6 - Finish upload



Figure 5-7: Progress bar

01 You can monitor .hex file uploading via progress bar.

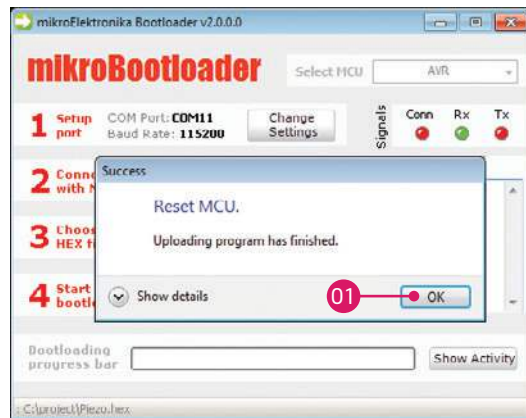

Figure 5-8: Browse for HEX

01 Click **OK** button.

02 Press **Reset button** on Ready board and wait for 5 seconds. Your program will execute automatically.

Programming with AVRprog™

programmer

Ready for AVR board contains IDC10 male headers for connecting **AVRprog™** external USB 2.0 programmer. When connecting, make sure to orient the programmer connector so that first pins on both male and female header connectors align. Correct connector placement is shown on Figure 5-9.

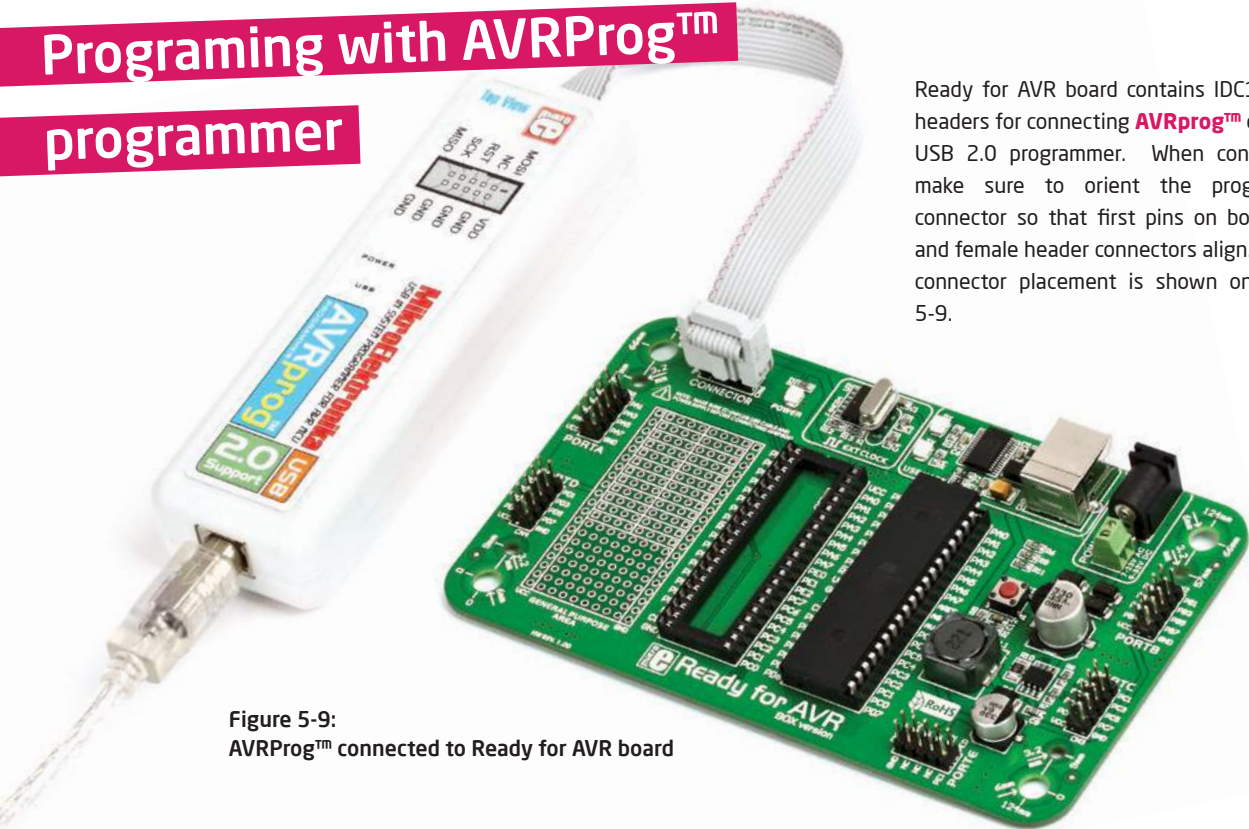

Figure 5-9:
AVRprog™ connected to Ready for AVR board

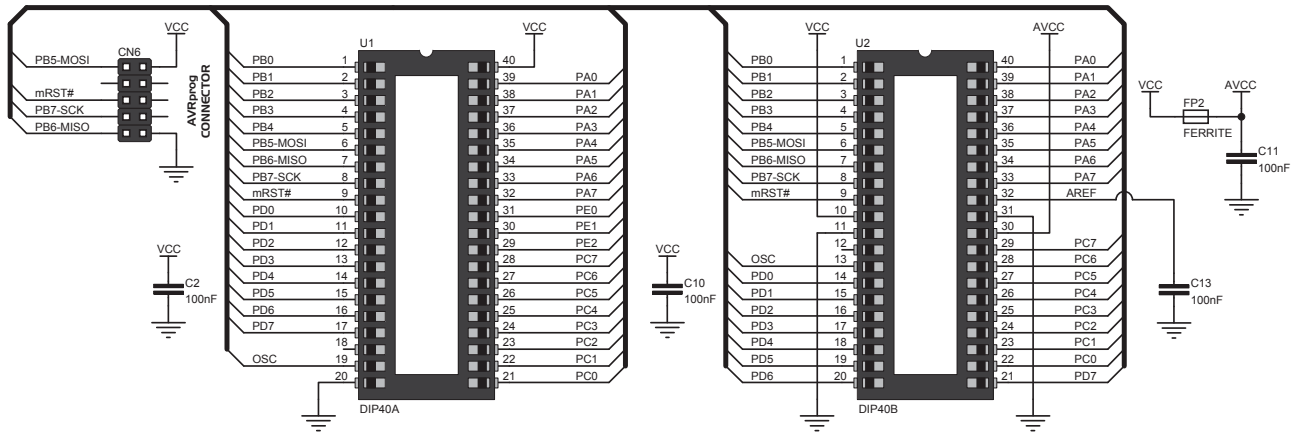

Figure 5-10: AVRprog™ connector schematics

6. USB-UART

Fast on-board FTDI chip allows you to communicate with a PC or other UART devices using USB-UART connection. Female USB Type-B connector (**CN9**) is used for connecting the USB cable. RX and TX LEDs will indicate communication status. Before connecting the board with the PC, make sure to have the appropriate FTDI drivers installed on your operating system. Drivers can be found at following URL: <http://www.ftdichip.com/Drivers/VCP.htm>

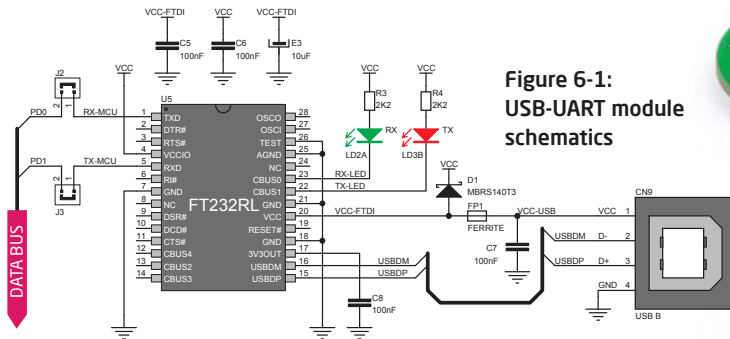

Figure 6-1:
USB-UART module
schematics



Figure 6-2:
USB cable connected

7. Port headers

Each microcontroller pin is available for further connections through on-board connection headers. Pins are clearly marked which makes them easier to interface. IDC10 headers are compatible with over 70 additional boards from mikroElektronika, so you can easily add new features to the base Ready for AVR board.

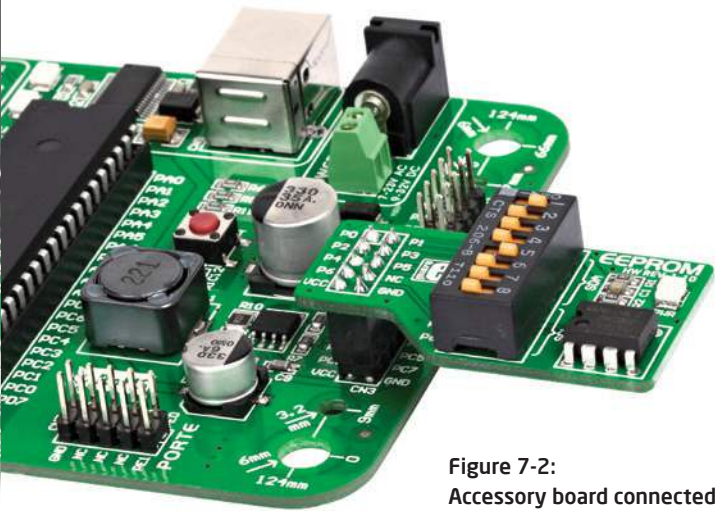

Figure 7-2:
Accessory board connected

DATA BUS

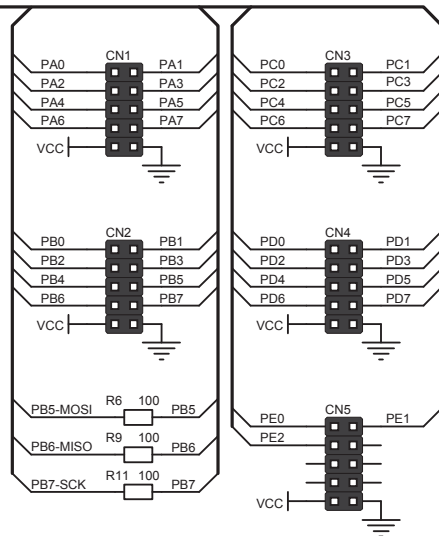

Figure 7-1:
Port headers
connection schematics

8. General Purpose Area

General Purpose Area allows you to expand your Ready for AVR board with additional functionalities, by placing your additional components into available soldering pads. Pads are arranged in standard 100mil distance form factor. There are 12 connected lines on both halves of the breadboard area, and each line consists of 4 soldering pads. 8x8 matrix of unconnected soldering pads are located in the lower section. VCC and GND lines are also available on the ending sides of the entire breadboard area.

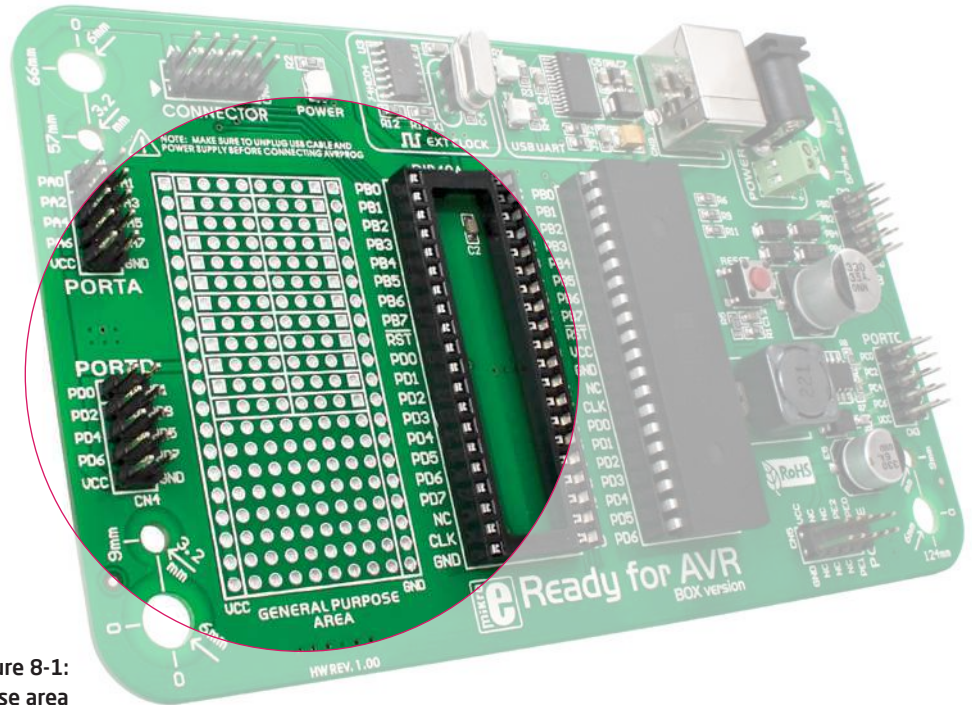

Figure 8-1:
General purpose area

9. Integrating with the casing



Figure 9-1: Integrating the board with the casing

Ready for AVR can easily be integrated into the specialized white plastic casing. This feature is very convenient for turning the board into a final product. The white plastic casing contains inner and outer screw holes. Inner are used for attaching the board to the casing, and outer are used for connecting the top part of the casing, and enclosing the board. Casing comes with holes for USB and power adapter connector, but you can customize it by drilling and cutting holes in specific areas, depending on the target application. Casing does not provide hydro insulation.



Figure 9-2: Board assembled with the casing to form a final product

10. Dimensions

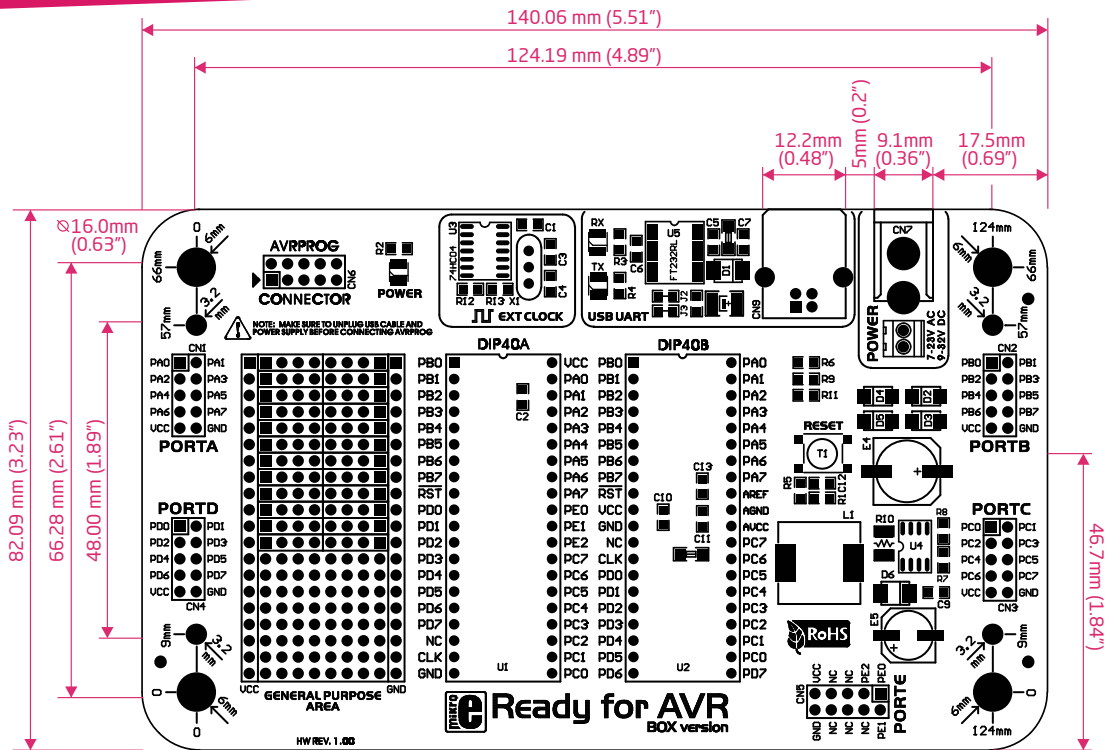

DISCLAIMER

All the products owned by MikroElektronika are protected by copyright law and international copyright treaty. Therefore, this manual is to be treated as any other copyright material. No part of this manual, including product and software described herein, may be reproduced, stored in a retrieval system, translated or transmitted in any form or by any means, without the prior written permission of MikroElektronika. The manual PDF edition can be printed for private or local use, but not for distribution. Any modification of this manual is prohibited.

MikroElektronika provides this manual 'as is' without warranty of any kind, either expressed or implied, including, but not limited to, the implied warranties or conditions of merchantability or fitness for a particular purpose.

MikroElektronika shall assume no responsibility or liability for any errors, omissions and inaccuracies that may appear in this manual. In no event shall MikroElektronika, its directors, officers, employees or distributors be liable for any indirect, specific, incidental or consequential damages (including damages for loss of business profits and business information, business interruption or any other pecuniary loss) arising out of the use of this manual or product, even if MikroElektronika has been advised of the possibility of such damages. MikroElektronika reserves the right to change information contained in this manual at any time without prior notice, if necessary.

HIGH RISK ACTIVITIES

The products of MikroElektronika are not fault - tolerant nor designed, manufactured or intended for use or resale as on - line control equipment in hazardous environments requiring fail - safe performance, such as in the operation of nuclear facilities, aircraft navigation or communication systems, air traffic control, direct life support machines or weapons systems in which the failure of Software could lead directly to death, personal injury or severe physical or environmental damage ('High Risk Activities'). MikroElektronika and its suppliers specifically disclaim any expressed or implied warranty of fitness for High Risk Activities.

TRADEMARKS

The MikroElektronika name and logo, the MikroElektronika logo, mikroC, mikroC PRO, mikroBasic, mikroBasic PRO, mikroPascal, mikroPascal PRO, AVRflash, PICflash, dsPICprog, 18FJprog, PSOCprog, AVRprog, 8051prog, ARMflash, EasyPIC5, EasyPIC6, BigPIC5, BigPIC6, dsPIC PRO4, Easy8051B, EasyARM, EasyAVR5, EasyAVR6, BigAVR2, EasydsPIC4A, EasyPSoc4, EasyVR Stamp LV18FJ, LV24-33A, LV32MX, PIC32MX4 MultiMedia Board, PICPLC16, PICPLC8 PICPLC4, SmartGSM/GPRS, UNI-DS are trademarks of Mikroelektronika. All other trademarks mentioned herein are property of their respective companies.

All other product and corporate names appearing in this manual may or may not be registered trademarks or copyrights of their respective companies, and are only used for identification or explanation and to the owners' benefit, with no intent to infringe.

Ready^{for AVR}

box version

If you want to learn more about our products, please visit our website at www.mikroe.com

If you are experiencing some problems with any of our products or just need additional information, please place your ticket at www.mikroe.com/en/support

If you have any questions, comments or business proposals,
do not hesitate to contact us at office@mikroe.com