



# PSRAM Camera Module with ESP32 WROVER (OV2640)

SKU: U017

## Description

**M5Camera** is a development board for image recognition. It features an ESP32(4M Flash + 520K RAM + 4M psram) chip and 2-Megapixel camera(OV2640).**M5Camera** offers plenty of storage, with an extra 4 Mbyte PSRAM. It also supports image transmission via Wi-Fi and debugging through USB Type-C port.

The hardware comes preloaded software, programmed by ESP-IDF. It is an application to run Wi-Fi camera. The output image is size 600\*800, since it's 2-Mega camera, you sure can optimize the software to output the maximum size of photos.

what this software can do?

- Power the board via USB type-C or GROVE
- Use your phone to Wi-Fi scan an AP name start with 'm5stack-' and click to connect this AP.
- Open up web browser on your phone and visit 192.168.4.1
- Then here comes the picture. Video is about 5-6 frames per seconds. not super fast.

The hardware also comes with some reserved weld pad, just in case you want put these chips back on board.

- 9-axis gyroscope (MPU6050)
- pressure sensor (BMP280)
- **Analog MIC (SPQ2410)**
- Battery socket

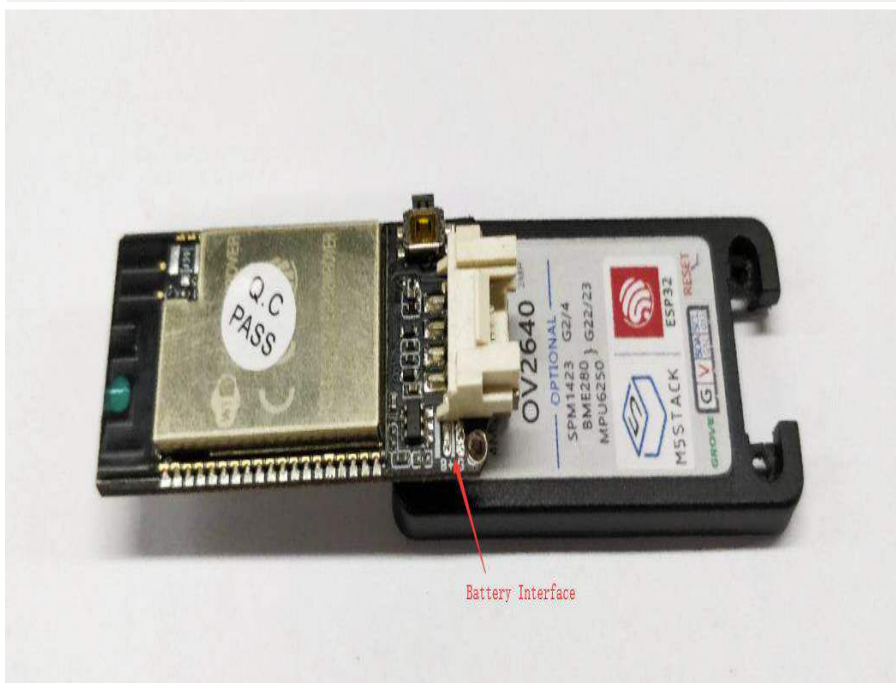

# Product Features

- ESP32 specifications
  - Dual-core Tensilica LX6 microprocessor
  - Up to 240MHz clock frequency
  - **4MB PSRAM**
  - **4MB Flash memory**
  - Integrated 802.11 BGN WiFi transceiver
  - Integrated dual-mode Bluetooth (classic and BLE)
  - Hardware accelerated encryption (AES, SHA2, ECC, RSA-4096)
- CP2104 USB-to-TTL converter
- OV2640 sensor
  - Output Formats(8-bit):
    - YUV(422/420)/YCbCr422
    - RGB565/555
    - 8-bit compressed data
    - 8-/10-bit Raw RGB data
  - Maximum Image Transfer Rate according to specific format
    - UXGA/SXGA: 15fps
    - SVGA: 30fps
    - CIF: 60fps
  - Scan Mode: Progressive
- Camera specifications
  - CCD size : 1/4 inch
  - Field of View : **65 degree**
  - Maximum Pixel: 2M
- Sensor best resolution: 1600 \* 1200
- Dimension: 40 × 49 × 13mm

## Kit includes

- 1x M5Camera
- 4x LEGO block
- 1x Type-C USB(20cm)

## Preloaded Software

M5Camera(A model) Firmware: <https://github.com/m5stack/m5stack-cam-psram/tree/master>

M5Camera(B model) Firmware: <https://github.com/m5stack/m5stack-cam-psram/tree/master>

### **Example**

- [Color recognition](#)
- [Face recognition](#)

# PinMap

There are two versions of M5Camera Unit: A Model and B Model.  
Camera Interface PinMap

<i>Interface</i>	<i>Camera Pin</i>	<i>M5Camera(A model)</i>	<i>M5Camera(B model)</i>
SCCB Clock	SIOC	IO23	IO23
SCCB Data	SIOD	<b>IO25</b>	<b>IO22</b>
System Clock	XCLK	IO27	IO27
Vertical Sync	VSYNC	<b>IO22</b>	<b>IO25</b>
Horizontal Reference	HREF	IO26	IO26
Pixel Clock	PCLK	IO21	IO21
Pixel Data Bit 0	D2	IO32	IO32
Pixel Data Bit 1	D3	IO35	IO35
Pixel Data Bit 2	D4	IO34	IO34
Pixel Data Bit 3	D5	IO5	IO5
Pixel Data Bit 4	D6	IO39	IO39

<i>Interface</i>	<i>Camera Pin</i>	<i>M5Camera(A model)</i>	<i>M5Camera(B model)</i>
Pixel Data Bit 5	D7	IO18	IO18
Pixel Data Bit 6	D8	IO36	IO36
Pixel Data Bit 7	D9	IO19	IO19
Camera Reset	RESET	IO15	IO15
Camera Power Down	PWDN	<i>see Note 1</i>	<i>see Note 1</i>
Power Supply 3.3V	3V3	3V3	3V3
Ground	GND	GND	GND

**GROVE Interface**

<i>Grove</i>	<i>M5Camera(A model)</i>	<i>M5Camera(B model)</i>
SCL	IO13	IO13
SDA	<b>IO12</b>	<b>IO4</b>
5V	5V	5V

<i>Grove</i>	<i>M5Camera(A model)</i>	<i>M5Camera(B model)</i>
GND	GND	GND

#### **LED Interface**

<i>LED</i>	<i>M5Camera(A model)</i>	<i>M5Camera(B model)</i>
LED_Pin	IO14	IO14

The following tables are Reserved Chip Interfaces

#### **BME280 Interface**

*It's IIC address is 0x76.*

<i>BME280</i>	<i>M5Camera(A model)</i>	<i>M5Camera(B model)</i>
SCL	IO23	IO23
SDA	IO22	IO22

#### **MPU6050 Interface**

*It's IIC address is 0x68.*

<i>MPU6050</i>	<i>M5Camera(A model)</i>	<i>M5Camera(B model)</i>
SCL	IO23	IO23
SDA	IO22	IO22

## MIC(SPM1423) Interface

MIC(SPM1423)	M5Camera(A model)	M5Camera(B model)
SCL	IO2	IO2
SDA	IO4	IO4

### NOTE:

- We have several patterns of camera board, the following figures shows the main difference

view click [here](#).

download click [here](#).

## Schematic

### Power circuit

#### 5V -> 3.3V DCDC Buck

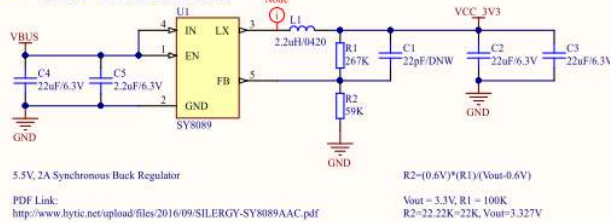

#### 3.3V->2V5 & 1V8 LDO

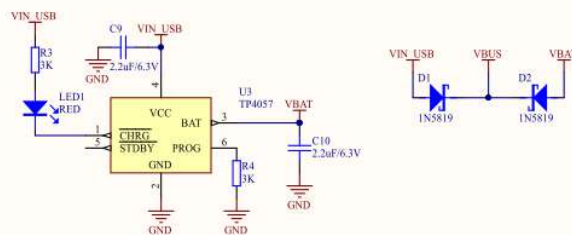
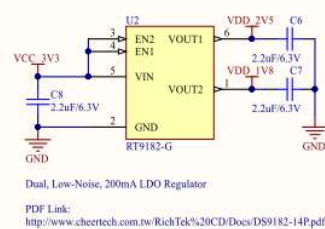

Title		
Size	Number	Revision
A		

# Chip peripheral circuit

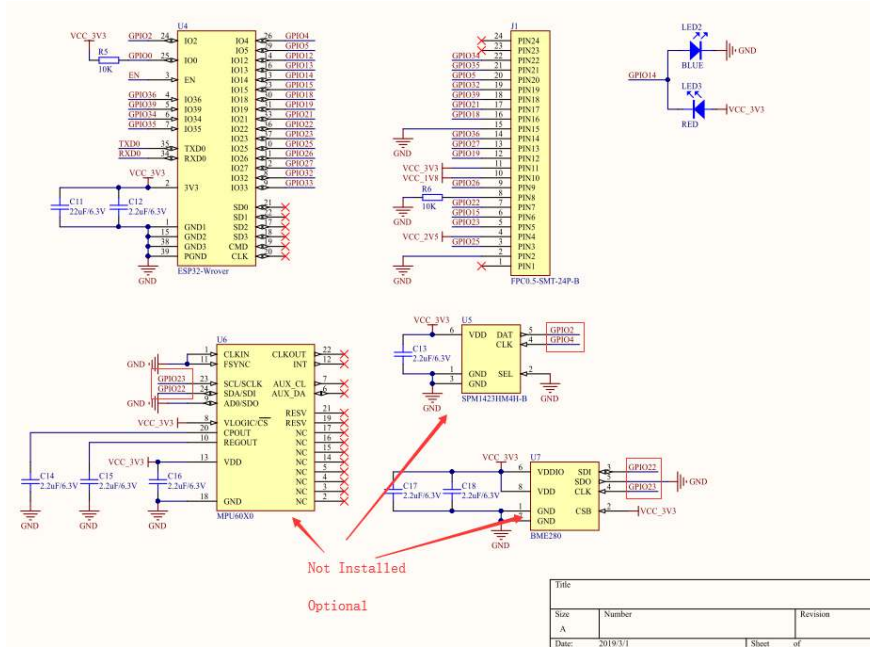

# USB to serial port part of the circuit

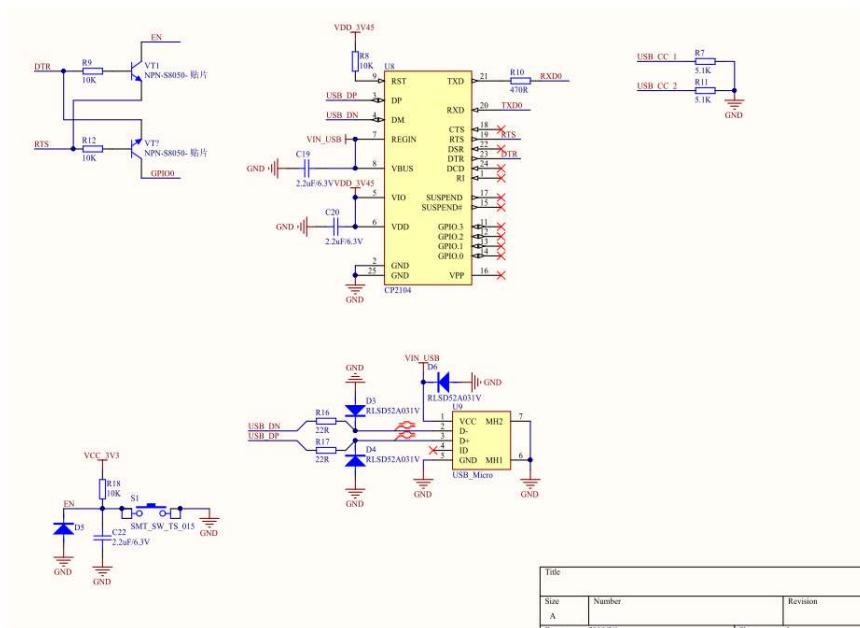







# Schematic

**OV2640**



**D2-9**  
 G32/35/34/5/39/18/36/19  
 HREF:G26 VSYNC:G22  
 RESET:G15  
 SIOC:G23 SIOD:G25



G3 ↑ ↓ G1



1V8 2V5

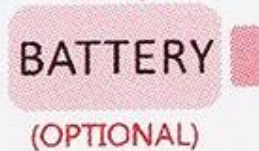

## OPTIONAL

