

FEATURES

- Member of the Texas Instruments Widebus+™ Family
- UBT™ Transceiver Combines D-Type Latches and D-Type Flip-Flops for Operation in Transparent, Latched, Clocked, and Clock-Enabled Modes
- TI-OPC™ Circuitry Limits Ringing on Unevenly Loaded Backplanes
- OEC™ Circuitry Improves Signal Integrity and Reduces Electromagnetic Interference
- Bidirectional Interface Between GTLP Signal Levels and LVTTTL Logic Levels
- GTLP Buffered CLKAB Signal (CLKOUT)
- LVTTTL Interfaces Are 5-V Tolerant
- Medium-Drive GTLP Outputs (50 mA)
- LVTTTL Outputs (–24 mA/24 mA)
- GTLP Rise and Fall Times Designed for Optimal Data-Transfer Rate and Signal Integrity in Distributed Loads
- I_{off}, Power-Up 3-State, and BIAS V_{CC} Support Live Insertion
- Bus Hold on A-Port Data Inputs
- Distributed V_{CC} and GND Pins Minimize High-Speed Switching Noise
- Latch-Up Performance Exceeds 100 mA Per JESD 78, Class II
- ESD Protection Exceeds JESD 22
 - 2000-V Human-Body Model (A114-A)
 - 200-V Machine Model (A115-A)
 - 1000-V Charged-Device Model (C101)

DESCRIPTION/ORDERING INFORMATION

The SN74GTLPH32916 is a medium-drive, 34-bit UBT transceiver that provides LVTTTL-to-GTLP and GTLP-to-LVTTTL signal-level translation. It allows for transparent, latched, clocked, and clock-enabled modes of data transfer. Additionally, it provides for a copy of CLKAB at GTLP signal levels (CLKOUT) and conversion of a GTLP clock to LVTTTL logic levels (CLKIN). The device provides a high-speed interface between cards operating at LVTTTL logic levels and a backplane operating at GTLP signal levels. High-speed (about three times faster than standard TTL or LVTTTL) backplane operation is a direct result of GTLP's reduced output swing (<1 V), reduced input threshold levels, improved differential input, OEC circuitry, and TI-OPC circuitry. Improved GTLP OEC and TI-OPC circuits minimize bus-settling time and have been designed and tested using several backplane models. The medium drive allows incident-wave switching in heavily loaded backplanes with equivalent load impedance down to 19 Ω.

GTLP is the Texas Instruments derivative of the Gunning Transceiver Logic (GTL) JEDEC standard JESD 8-3. The ac specification of the SN74GTLPH32916 is given only at the preferred higher noise-margin GTLP, but the user has the flexibility of using this device at either GTL (V_{TT} = 1.2 V and V_{REF} = 0.8 V) or GTLP (V_{TT} = 1.5 V and V_{REF} = 1 V) signal levels.

Normally, the B port operates at GTLP signal levels. The A-port and control inputs operate at LVTTTL logic levels, but are 5-V tolerant and are compatible with TTL and 5-V CMOS inputs. V_{REF} is the B-port differential input reference voltage.

This device is fully specified for live-insertion applications using I_{off}, power-up 3-state, and BIAS V_{CC}. The I_{off} circuitry disables the outputs, preventing damaging current backflow through the device when it is powered down. The power-up 3-state circuitry places the outputs in the high-impedance state during power up and power down, which prevents driver conflict. The BIAS V_{CC} circuitry precharges and preconditions the B-port input/output connections, preventing disturbance of active data on the backplane during card insertion or removal, and permits true live-insertion capability.

ORDERING INFORMATION

T _A	PACKAGE ⁽¹⁾		ORDERABLE PART NUMBER	TOP-SIDE MARKING
–40°C to 85°C	LFBGA – GKF	Tape and reel	SN74GTLPH32916KR	GM916

- (1) Package drawings, standard packing quantities, thermal data, symbolization, and PCB design guidelines are available at www.ti.com/sc/package.



Please be aware that an important notice concerning availability, standard warranty, and use in critical applications of Texas Instruments semiconductor products and disclaimers thereto appears at the end of this data sheet.

Widebus+, UBT, TI-OPC, OEC are trademarks of Texas Instruments.

SN74GTLPH32916
34-BIT LVTTTL-TO-GTLP UNIVERSAL BUS TRANSCEIVER
WITH BUFFERED CLOCK OUTPUTS

SCES380A—JANUARY 2002—REVISED JUNE 2005

DESCRIPTION/ORDERING INFORMATION (CONTINUED)

This GTLP device features TI-OPC circuitry, which actively limits the overshoot caused by improperly terminated backplanes, unevenly distributed cards, or empty slots during low-to-high signal transitions. This improves signal integrity, which allows adequate noise margin to be maintained at higher frequencies.

Active bus-hold circuitry holds unused or undriven LVTTTL data inputs at a valid logic state. Use of pullup or pulldown resistors with the bus-hold circuitry is not recommended.

When V_{CC} is between 0 and 1.5 V, the device is in the high-impedance state during power up or power down. However, to ensure the high-impedance state above 1.5 V, the output-enable (\overline{OE}) input should be tied to V_{CC} through a pullup resistor; the minimum value of the resistor is determined by the current-sinking capability of the driver.

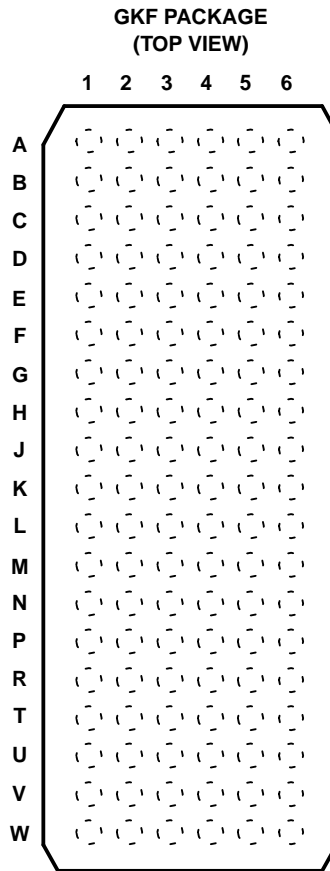

TERMINAL ASSIGNMENTS⁽¹⁾

	1	2	3	4	5	6
A	1A2	1A1	1LEAB	1CLKAB	1B1	1B2
B	1A4	1A3	1 \overline{OEAB}	1 \overline{CEAB}	1B3	1B4
C	1A6	1A5	GND	GND	1B5	1B6
D	1A8	1A7	1V _{CC}	1BIAS V _{CC}	1B7	1B8
E	1A10	1A9	GND	GND	1B9	1B10
F	1A12	1A11	GND	GND	1B11	1B12
G	1A14	1A13	1V _{CC}	1V _{REF}	1B13	1B14
H	1A15	1A16	GND	GND	1B16	1B15
J	1A17	1CLKIN	1 \overline{OEBA}	1CLKBA	1CLKOUT	1B17
K	NC	2LEAB	1LEBA	1 \overline{CEBA}	2CLKAB	NC
L	2A2	2A1	2 \overline{OEAB}	2 \overline{CEAB}	2B1	2B2
M	2A4	2A3	GND	GND	2B3	2B4
N	2A6	2A5	2V _{CC}	2BIAS V _{CC}	2B5	2B6
P	2A8	2A7	GND	GND	2B7	2B8
R	2A10	2A9	GND	GND	2B9	2B10
T	2A12	2A11	2V _{CC}	2V _{REF}	2B11	2B12
U	2A14	2A13	GND	GND	2B13	2B14
V	2A15	2A16	2 \overline{OEBA}	2CLKBA	2B16	2B15
W	2A17	2CLKIN	2LEBA	2 \overline{CEBA}	2CLKOUT	2B17

(1) NC - No internal connection

FUNCTIONAL DESCRIPTION

The SN74GTLPH32916 is a medium-drive (50 mA), 34-bit UBT transceiver containing D-type latches and D-type flip-flops for data-path operation in transparent, latched, clocked, or clock-enabled modes and can replace any of the functions shown in Table 1. Data polarity is noninverting.

Table 1. SN74GTLPH32916 UBT Transceiver Replacement Functions

FUNCTION	8 BIT	9 BIT	10 BIT	16 BIT	18 BIT
Transceiver	'245, '623, '645	'863	'861	'16245, '16623	'16863
Buffer/driver	'241, '244, '541		'827	'16241, '16244, '16541	'16825
Latched transceiver	'543			'16543	'16472
Latch	'373, '573	'843	'841	'16373	'16843
Registered transceiver	'646, '652			'16646, '16652	'16474
Flip-flop	'374, '574		'821	'16374	
Standard UBT					'16500, '16501
Universal bus driver					'16835
Registered transceiver with clock enable	'2952			'16470, '16952	
Flip-flop with clock enable	'377	'823			'16823
Standard UBT with clock enable					'16600, '16601
SN74GTLPH32916 UBT transceiver replaces all above functions					

SN74GTLPH32916
34-BIT LVTTTL-TO-GTLP UNIVERSAL BUS TRANSCEIVER
WITH BUFFERED CLOCK OUTPUTS

SCES380A—JANUARY 2002—REVISED JUNE 2005

FUNCTIONAL DESCRIPTION (CONTINUED)

Additionally, it allows for transparent conversion of CLKAB-to-GTLP signal levels (CLKOUT) and CLKOUT-to-LVTTTL logic levels (CLKIN).

Data flow in each direction is controlled by clock enables (\overline{CEAB} and \overline{CEBA}), latch enables (LEAB and LEBA), clock (CLKAB and CLKBA), and output enables (\overline{OEAB} and \overline{OEBA}). \overline{CEAB} and \overline{CEBA} enable all 17 bits, and \overline{OEAB} and \overline{OEBA} control the 17 bits of data and the CLKOUT/CLKIN buffered clock path for the A-to-B and B-to-A directions, respectively.

For A-to-B data flow, when \overline{CEAB} is low, the device operates on the low-to-high transition of CLKAB for the flip-flop and on the high-to-low transition of LEAB for the latch path, i.e., if \overline{CEAB} and LEAB are low, the A data is latched, regardless of the state of CLKAB (high or low) and if LEAB is high, the device is in transparent mode. When \overline{OEAB} is low, the outputs are active. When \overline{OEAB} is high, the outputs are in the high-impedance state.

The data flow for B to A is similar to A to B, except \overline{CEBA} , \overline{OEBA} , LEBA, and CLKBA are used.

FUNCTION TABLES

OUTPUT ENABLE⁽¹⁾

INPUTS					OUTPUT B	MODE
\overline{CEAB}	\overline{OEAB}	LEAB	CLKAB	A		
X	H	X	X	X	Z	Isolation
L	L	L	H	X	B ₀ ⁽²⁾	Latched storage of A data
L	L	L	L	X	B ₀ ⁽³⁾	
X	L	H	X	L	L	True transparent
X	L	H	X	H	H	
L	L	L	↑	L	L	Clocked storage of A data
L	L	L	↑	H	H	
H	L	L	X	X	B ₀ ⁽³⁾	Clock inhibit

- (1) A-to-B data flow is shown. B-to-A data flow is similar, but uses \overline{CEBA} , \overline{OEBA} , LEBA, and CLKBA. The condition when \overline{OEAB} and \overline{OEBA} are both low at the same time is not recommended.
- (2) Output level before the indicated steady-state input conditions were established, provided that CLKAB was high before LEAB went low
- (3) Output level before the indicated steady-state input conditions were established

BUFFERED CLOCK

INPUTS				OPERATION OR FUNCTION	MODE
\overline{CE}	LE	\overline{OEAB}	\overline{OEBA}		
X	X	H	H	Z	Isolation
X	X	L	H	CLKAB to CLKOUT	True delayed clock signal
X	X	H	L	CLKOUT to CLKIN	
X	X	L	L	CLKAB to CLKOUT, CLKOUT to CLKIN	True delayed clock signal with feedback path ⁽¹⁾

- (1) This condition is not recommended.

LOGIC DIAGRAM (POSITIVE LOGIC)⁽¹⁾

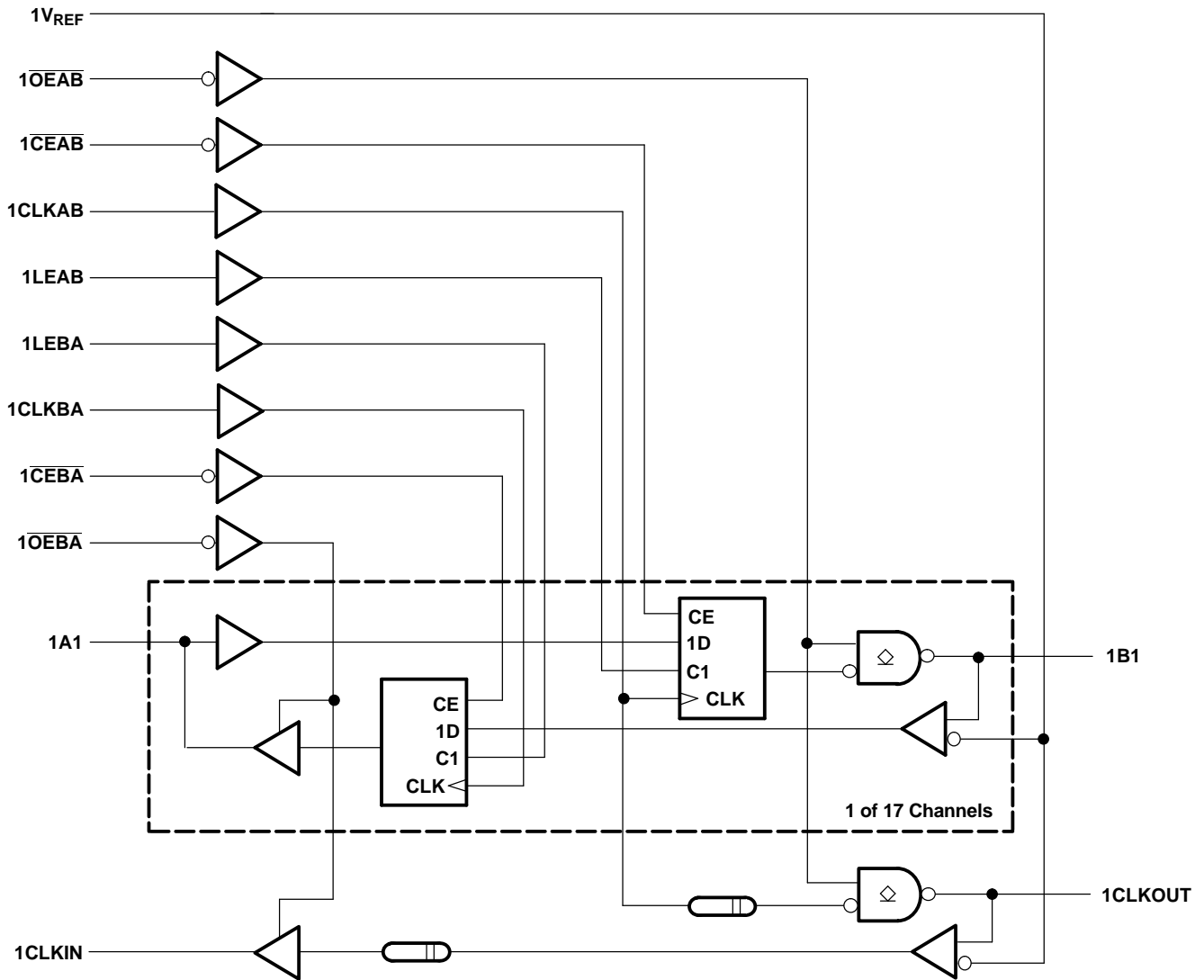

(1) $1V_{CC}$ and $1BIAS V_{CC}$ are associated with these channels.

SN74GTLPH32916
34-BIT LVTTTL-TO-GTLP UNIVERSAL BUS TRANSCEIVER
WITH BUFFERED CLOCK OUTPUTS

SCES380A—JANUARY 2002—REVISED JUNE 2005

LOGIC DIAGRAM (POSITIVE LOGIC)⁽¹⁾(CONTINUED)

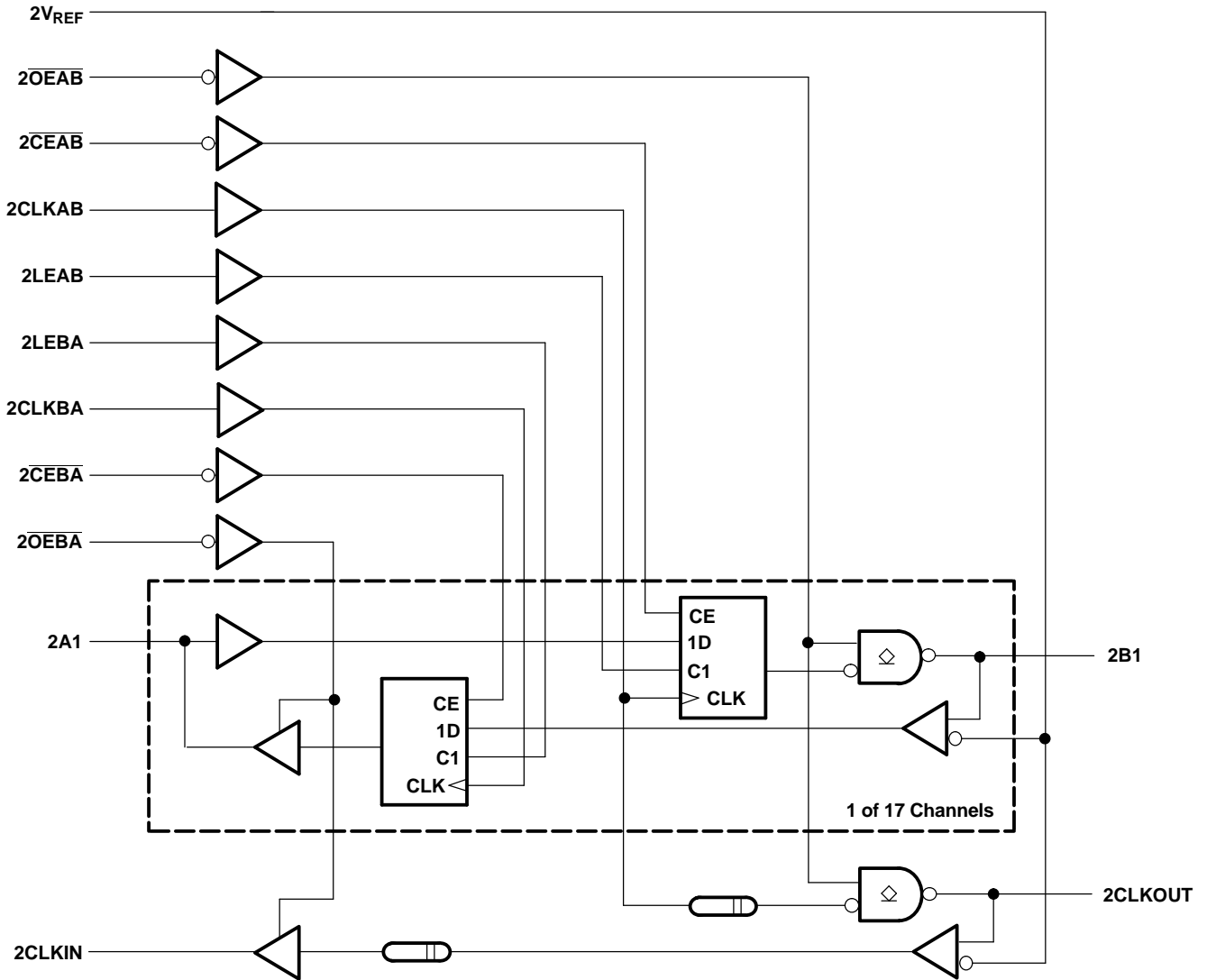

(1) $2V_{CC}$ and $2BIAS V_{CC}$ are associated with these channels.

Absolute Maximum Ratings⁽¹⁾

over operating free-air temperature range (unless otherwise noted)

		MIN	MAX	UNIT
V_{CC} BIAS V_{CC}	Supply voltage range	-0.5	4.6	V
V_I	Input voltage range ⁽²⁾	A-port and control inputs		V
		B port and V_{REF}		
V_O	Voltage range applied to any output in the high-impedance or power-off state ⁽²⁾	A port		V
		B port		
I_O	Current into any output in the low state	A port		mA
		B port		
I_O	Current into any A-port output in the high state ⁽³⁾	48		mA
Continuous current through each V_{CC} or GND		±100		mA
I_{IK}	Input clamp current	$V_I < 0$		mA
I_{OK}	Output clamp current	$V_O < 0$		mA
θ_{JA}	Package thermal impedance ⁽⁴⁾	36		°C/W
T_{stg}	Storage temperature range	-65	150	°C

- (1) Stresses beyond those listed under "absolute maximum ratings" may cause permanent damage to the device. These are stress ratings only, and functional operation of the device at these or any other conditions beyond those indicated under "recommended operating conditions" is not implied. Exposure to absolute-maximum-rated conditions for extended periods may affect device reliability.
- (2) The input and output negative-voltage ratings may be exceeded if the input and output clamp-current ratings are observed.
- (3) This current flows only when the output is in the high state and $V_O > V_{CC}$.
- (4) The package thermal impedance is calculated in accordance with JESD 51-7.

SN74GTLPH32916
34-BIT LVTTTL-TO-GTLP UNIVERSAL BUS TRANSCEIVER
WITH BUFFERED CLOCK OUTPUTS



SCES380A–JANUARY 2002–REVISED JUNE 2005

Recommended Operating Conditions⁽¹⁾⁽²⁾⁽³⁾⁽⁴⁾

			MIN	NOM	MAX	UNIT	
V_{CC} , BIAS V_{CC}	Supply voltage		3.15	3.3	3.45	V	
V_{TT}	Termination voltage	GTL	1.14	1.2	1.26	V	
		GTLP	1.35	1.5	1.65		
V_{REF}	Reference voltage	GTL	0.74	0.8	0.87	V	
		GTLP	0.87	1	1.1		
V_I	Input voltage	B port	V_{TT}			V	
		Except B port	V_{CC}				
V_{IH}	High-level input voltage	B port	$V_{REF} + 0.05$			V	
		Except B port	2				
V_{IL}	Low-level input voltage	B port	$V_{REF} - 0.05$			V	
		Except B port	0.8				
I_{IK}	Input clamp current				-18	mA	
I_{OH}	High-level output current	A port				-24	mA
I_{OL}	Low-level output current	A port				24	mA
		B port				50	
$\Delta t/\Delta v$	Input transition rise or fall rate	Outputs enabled				10	ns/V
$\Delta t/\Delta V_{CC}$	Power-up ramp rate		20				μ s/V
T_A	Operating free-air temperature		-40		85		$^{\circ}$ C

- (1) All unused inputs of the device must be held at V_{CC} or GND to ensure proper device operation. Refer to the TI application report, *Implications of Slow or Floating CMOS Inputs*, literature number SCBA004.
- (2) Proper connection sequence for use of the B-port I/O precharge feature is GND and BIAS $V_{CC} = 3.3$ V first, I/O second, and $V_{CC} = 3.3$ V last, because the BIAS V_{CC} precharge circuitry is disabled when any V_{CC} pin is connected. The control and V_{REF} inputs can be connected anytime, but normally are connected during the I/O stage. If B-port precharge is not required, any connection sequence is acceptable, but generally, GND is connected first.
- (3) V_{TT} and R_{TT} can be adjusted to accommodate backplane impedances if the dc recommended I_{OL} ratings are not exceeded.
- (4) V_{REF} can be adjusted to optimize noise margins, but normally is two-thirds V_{TT} . TI-OPC circuitry is enabled in the A-to-B direction and is activated when $V_{TT} > 0.7$ V above V_{REF} . If operated in the A-to-B direction, V_{REF} should be set to within 0.6 V of V_{TT} to minimize current drain.

Electrical Characteristics

over recommended operating free-air temperature range for GTLP (unless otherwise noted)

PARAMETER		TEST CONDITIONS		MIN	TYP ⁽¹⁾	MAX	UNIT	
V_{IK}		$V_{CC} = 3.15\text{ V}$,	$I_I = -18\text{ mA}$			-1.2	V	
V_{OH}	A port	$V_{CC} = 3.15\text{ V to } 3.45\text{ V}$,	$I_{OH} = -100\text{ }\mu\text{A}$	$V_{CC} - 0.2$			V	
		$V_{CC} = 3.15\text{ V}$	$I_{OH} = -12\text{ mA}$	2.4				
			$I_{OH} = -24\text{ mA}$	2				
V_{OL}	A port	$V_{CC} = 3.15\text{ V to } 3.45\text{ V}$,	$I_{OL} = 100\text{ }\mu\text{A}$			0.2	V	
		$V_{CC} = 3.15\text{ V}$	$I_{OL} = 12\text{ mA}$			0.4		
			$I_{OL} = 24\text{ mA}$			0.5		
	B port	$V_{CC} = 3.15\text{ V to } 3.45\text{ V}$,	$I_{OL} = 100\text{ }\mu\text{A}$			0.2		
		$V_{CC} = 3.15\text{ V}$	$I_{OL} = 10\text{ mA}$			0.2		
			$I_{OL} = 40\text{ mA}$			0.4		
		$I_{OL} = 50\text{ mA}$			0.55			
I_I	Control inputs	$V_{CC} = 3.45\text{ V}$,	$V_I = 0\text{ or } 5.5\text{ V}$			± 10	μA	
$I_{OZH}^{(2)}$	A port	$V_{CC} = 3.45\text{ V}$	$V_O = V_{CC}$			10	μA	
	B port		$V_O = 1.5\text{ V}$			10		
$I_{OZL}^{(2)}$	A and B ports	$V_{CC} = 3.45\text{ V}$,	$V_O = \text{GND}$			-10	μA	
$I_{BHL}^{(3)}$	A port	$V_{CC} = 3.15\text{ V}$,	$V_I = 0.8\text{ V}$			75	μA	
$I_{BHH}^{(4)}$	A port	$V_{CC} = 3.15\text{ V}$,	$V_I = 2\text{ V}$			-75	μA	
$I_{BHLO}^{(5)}$	A port	$V_{CC} = 3.45\text{ V}$,	$V_I = 0\text{ to } V_{CC}$			500	μA	
$I_{BHHO}^{(6)}$	A port	$V_{CC} = 3.45\text{ V}$,	$V_I = 0\text{ to } V_{CC}$			-500	μA	
I_{CC}	A or B port	$V_{CC} = 3.45\text{ V}$, $I_O = 0$, V_I (A port or control input) = V_{CC} or GND, V_I (B port) = V_{TT} or GND	Outputs high			100	mA	
			Outputs low			100		
			Outputs disabled			100		
$\Delta I_{CC}^{(7)}$		$V_{CC} = 3.45\text{ V}$, One A-port or control input at $V_{CC} - 0.6\text{ V}$, Other A-port or control inputs at V_{CC} or GND				1.5	mA	
C_i	Control inputs	$V_I = 3.15\text{ V or } 0$				3	4	pF
C_{io}	A port	$V_O = 3.15\text{ V or } 0$				6.5	8	pF
	B port or CLKOUT	$V_O = 1.5\text{ V or } 0$				8.5	10.5	
C_o	CLKIN	$V_O = 3.15\text{ V or } 0$				5	6	pF

 (1) All typical values are at $V_{CC} = 3.3\text{ V}$, $T_A = 25^\circ\text{C}$.

 (2) For I/O ports, the parameters I_{OZH} and I_{OZL} include the input leakage current.

 (3) The bus-hold circuit can sink at least the minimum low sustaining current at V_{ILmax} . I_{BHL} should be measured after lowering V_{IN} to GND and then raising it to V_{ILmax} .

 (4) The bus-hold circuit can source at least the minimum high sustaining current at V_{IHmin} . I_{BHH} should be measured after raising V_{IN} to V_{CC} and then lowering it to V_{IHmin} .

 (5) An external driver must source at least I_{BHLO} to switch this node from low to high.

 (6) An external driver must sink at least I_{BHHO} to switch this node from high to low.

 (7) This is the increase in supply current for each input that is at the specified TTL voltage level, rather than V_{CC} or GND.

SN74GTLPH32916
34-BIT LVTTTL-TO-GTLP UNIVERSAL BUS TRANSCEIVER
WITH BUFFERED CLOCK OUTPUTS

SCES380A–JANUARY 2002–REVISED JUNE 2005

Hot-Insertion Specifications for A Port

over recommended operating free-air temperature range

PARAMETER	TEST CONDITIONS			MIN	MAX	UNIT
I_{off}	$V_{CC} = 0,$	BIAS $V_{CC} = 0,$	V_I or $V_O = 0$ to 5.5 V		10	μA
I_{OZPU}	$V_{CC} = 0$ to 1.5 V,	$V_O = 0.5$ V to 3 V,	$\overline{OE} = 0$		± 30	μA
I_{OZPD}	$V_{CC} = 1.5$ V to 0,	$V_O = 0.5$ V to 3 V,	$\overline{OE} = 0$		± 30	μA

Live-Insertion Specifications for B Port

over recommended operating free-air temperature range

PARAMETER	TEST CONDITIONS			MIN	MAX	UNIT
I_{off}	$V_{CC} = 0,$	BIAS $V_{CC} = 0,$	V_I or $V_O = 0$ to 1.5 V		10	μA
I_{OZPU}	$V_{CC} = 0$ to 1.5 V,	BIAS $V_{CC} = 0,$	$V_O = 0.5$ V to 1.5 V, $\overline{OE} = 0$		± 30	μA
I_{OZPD}	$V_{CC} = 1.5$ V to 0,	BIAS $V_{CC} = 0,$	$V_O = 0.5$ V to 1.5 V, $\overline{OE} = 0$		± 30	μA
I_{CC} (BIAS V_{CC})	$V_{CC} = 0$ to 3.15 V	BIAS $V_{CC} = 3.15$ V to 3.45 V,	V_O (B port) = 0 to 1.5 V		5	mA
	$V_{CC} = 3.15$ V to 3.45 V				10	μA
V_O	$V_{CC} = 0,$	BIAS $V_{CC} = 3.3$ V,	$I_O = 0$	0.95	1.05	V
I_O	$V_{CC} = 0,$	BIAS $V_{CC} = 3.15$ V to 3.45 V,	V_O (B port) = 0.6 V	-1		μA

Timing Requirements

over recommended ranges of supply voltage and operating free-air temperature,
 $V_{TT} = 1.5$ V and $V_{REF} = 1$ V for GTLP (unless otherwise noted)

			MIN	MAX	UNIT
f_{clock}	Clock frequency	CLKAB to B or CLKBA to A		175	MHz
t_w	Pulse duration	LEAB or LEBA high		2.8	ns
		CLKAB to B or CLKBA to A	High or low	2.8	
t_{su}	Setup time	A before CLKAB \uparrow		1.8	ns
		B before CLKBA \uparrow		1.5	
		A before LEAB \downarrow		1	
		B before LEBA \downarrow		2	
		\overline{CEAB} before CLKAB \uparrow		1.5	
		\overline{CEBA} before CLKBA \uparrow		1.5	
t_h	Hold time	A after CLKAB \uparrow		0.3	ns
		B after CLKBA \uparrow		0.4	
		A after LEAB \downarrow		1.1	
		B after LEBA \downarrow		0.5	
		\overline{CEAB} after CLKAB \uparrow		1	
		\overline{CEBA} after CLKBA \uparrow		1	

Switching Characteristics

over recommended ranges of supply voltage and operating free-air temperature,
 $V_{TT} = 1.5\text{ V}$ and $V_{REF} = 1\text{ V}$ for GTLP (see [Figure 1](#))

PARAMETER	FROM (INPUT)	TO (OUTPUT)	MIN	TYP ⁽¹⁾	MAX	UNIT
f_{max}	CLKAB or CLKBA	B or A	175			MHz
t_{PLH}	A	B	2.1		6	ns
t_{PHL}			2.1		6	
t_{PLH}	LEAB	B	2.2		6.5	ns
t_{PHL}			2.2		6.5	
t_{PLH}	CLKAB	B	2.2		6.5	ns
t_{PHL}			2.2		6.5	
t_{PLH}	CLKAB	CLKOUT	3.2		8	ns
t_{PHL}			3.2		8	
t_{en}	\overline{OEAB}	B or CLKOUT	2.2		6.5	ns
t_{dis}			2.2		6.5	
t_r	Rise time, B outputs (20% to 80%)		2.4			ns
t_f	Fall time, B outputs (80% to 20%)		2			ns
t_{PLH}	B	A	1.8		5.8	ns
t_{PHL}			1.8		5.8	
t_{PLH}	LEBA	A	1.5		5.3	ns
t_{PHL}			1.5		5.3	
t_{PLH}	CLKBA	A	1.8		5.7	ns
t_{PHL}			1.8		5.7	
t_{PLH}	CLKOUT	CLKIN	2.5		6.5	ns
t_{PHL}			2.5		6.5	
t_{en}	\overline{OEBA}	A or CLKIN	1		6.2	ns
t_{dis}			1		5.9	

(1) All typical values are at $V_{CC} = 3.3\text{ V}$, $T_A = 25^\circ\text{C}$.

PARAMETER MEASUREMENT INFORMATION

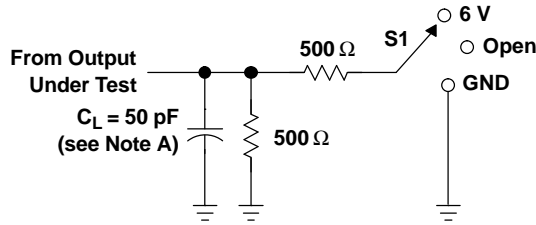

LOAD CIRCUIT FOR A OUTPUTS

TEST	S1
t_{PLH}/t_{PHL}	Open
t_{PLZ}/t_{PZL}	6 V
t_{PHZ}/t_{PZH}	GND

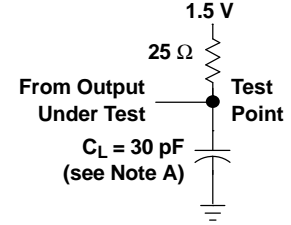

LOAD CIRCUIT FOR B OUTPUTS

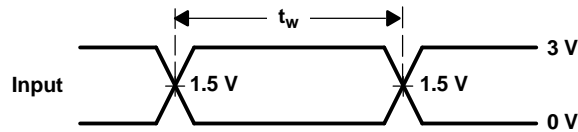

VOLTAGE WAVEFORMS
 PULSE DURATION

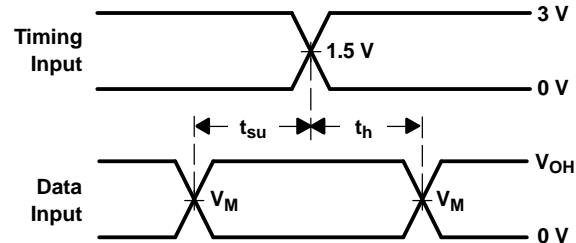

VOLTAGE WAVEFORMS
 SETUP AND HOLD TIMES
 ($V_M = 1.5$ V for A port and 1 V for B port)
 ($V_{OH} = 3$ V for A port and 1.5 V for B port)

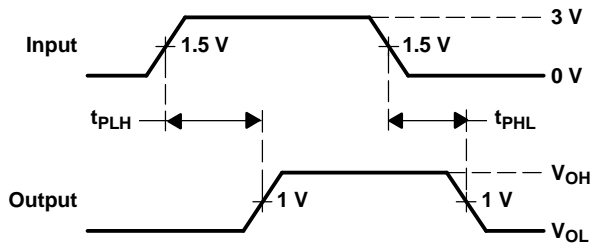

VOLTAGE WAVEFORMS
 PROPAGATION DELAY TIMES
 (A port to B port)

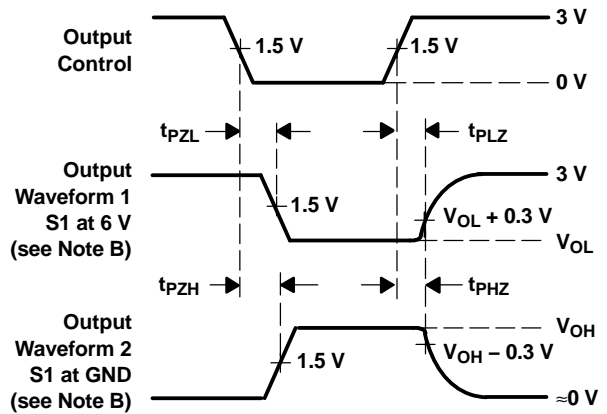

VOLTAGE WAVEFORMS
 ENABLE AND DISABLE TIMES
 (A port)

- NOTES: A. C_L includes probe and jig capacitance.
 B. Waveform 1 is for an output with internal conditions such that the output is low, except when disabled by the output control. Waveform 2 is for an output with internal conditions such that the output is high, except when disabled by the output control.
 C. All input pulses are supplied by generators having the following characteristics: PRR \approx 10 MHz, $Z_O = 50 \Omega$, $t_r \approx 2$ ns, $t_f \approx 2$ ns.
 D. The outputs are measured one at a time, with one transition per measurement.

Figure 1. Load Circuits and Voltage Waveforms

Distributed-Load Backplane Switching Characteristics

The preceding switching characteristics table shows the switching characteristics of the device into a lumped load (Figure 1). However, the designer's backplane application probably is a distributed load. The physical representation is shown in Figure 2. This backplane, or distributed load, can be approximated closely to a resistor inductance capacitance (RLC) circuit, as shown in Figure 3. This device has been designed for optimum performance in this RLC circuit. The following switching characteristics table shows the switching characteristics of the device into the RLC load, to help the designer better understand the performance of the GTLP device in this typical backplane. See www.ti.com/sc/gtlp for more information.

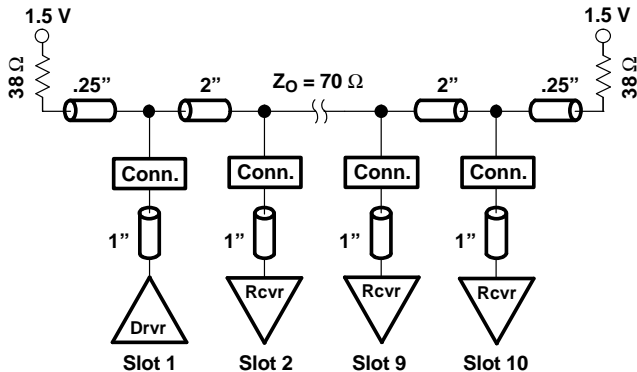

Figure 2. Medium-Drive Test Backplane

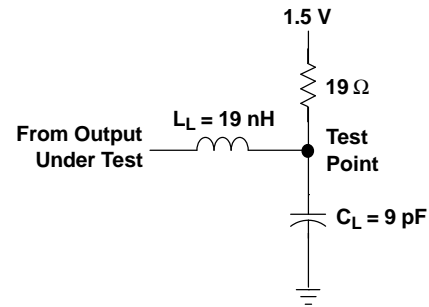

Figure 3. Medium-Drive RLC Network

Switching Characteristics

over recommended ranges of supply voltage and operating free-air temperature, $V_{TT} = 1.5\text{ V}$ and $V_{REF} = 1\text{ V}$ for GTLP (see [Figure 3](#))

PARAMETER	FROM (INPUT)	TO (OUTPUT)	TYP ⁽¹⁾	UNIT
t_{PLH}	A	B	4.5	ns
t_{PHL}			4.5	
t_{PLH}	LEAB	B	4.7	ns
t_{PHL}			4.7	
t_{PLH}	CLKAB	B	4.7	ns
t_{PHL}			4.7	
t_{PLH}	CLKAB	CLKOUT	6	ns
t_{PHL}			6	
t_{en}	\overline{OEAB}	B or CLKOUT	4.8	ns
t_{dis}			4.4	
t_r	Rise time, B outputs (20% to 80%)		1.2	ns
t_f	Fall time, B outputs (80% to 20%)		2.5	ns

(1) All typical values are at $V_{CC} = 3.3\text{ V}$, $T_A = 25^\circ\text{C}$. All values are derived from TI-SPICE models.

PACKAGING INFORMATION

Orderable Device	Status ⁽¹⁾	Package Type	Package Drawing	Pins	Package Qty	Eco Plan ⁽²⁾	Lead/Ball Finish	MSL Peak Temp ⁽³⁾
SN74GTLPH32916KR	NRND	BGA MI CROSTAR	GKF	114	1000	TBD	SNPB	Level-2-235C-1 YEAR
SN74GTLPH32916ZKFR	ACTIVE	LFBGA	ZKF	114	1000	Green (RoHS & no Sb/Br)	SNAGCU	Level-3-260C-168 HR

⁽¹⁾ The marketing status values are defined as follows:

ACTIVE: Product device recommended for new designs.

LIFEBUY: TI has announced that the device will be discontinued, and a lifetime-buy period is in effect.

NRND: Not recommended for new designs. Device is in production to support existing customers, but TI does not recommend using this part in a new design.

PREVIEW: Device has been announced but is not in production. Samples may or may not be available.

OBSOLETE: TI has discontinued the production of the device.

⁽²⁾ Eco Plan - The planned eco-friendly classification: Pb-Free (RoHS), Pb-Free (RoHS Exempt), or Green (RoHS & no Sb/Br) - please check <http://www.ti.com/productcontent> for the latest availability information and additional product content details.

TBD: The Pb-Free/Green conversion plan has not been defined.

Pb-Free (RoHS): TI's terms "Lead-Free" or "Pb-Free" mean semiconductor products that are compatible with the current RoHS requirements for all 6 substances, including the requirement that lead not exceed 0.1% by weight in homogeneous materials. Where designed to be soldered at high temperatures, TI Pb-Free products are suitable for use in specified lead-free processes.

Pb-Free (RoHS Exempt): This component has a RoHS exemption for either 1) lead-based flip-chip solder bumps used between the die and package, or 2) lead-based die adhesive used between the die and leadframe. The component is otherwise considered Pb-Free (RoHS compatible) as defined above.

Green (RoHS & no Sb/Br): TI defines "Green" to mean Pb-Free (RoHS compatible), and free of Bromine (Br) and Antimony (Sb) based flame retardants (Br or Sb do not exceed 0.1% by weight in homogeneous material)

⁽³⁾ MSL, Peak Temp. -- The Moisture Sensitivity Level rating according to the JEDEC industry standard classifications, and peak solder temperature.

Important Information and Disclaimer: The information provided on this page represents TI's knowledge and belief as of the date that it is provided. TI bases its knowledge and belief on information provided by third parties, and makes no representation or warranty as to the accuracy of such information. Efforts are underway to better integrate information from third parties. TI has taken and continues to take reasonable steps to provide representative and accurate information but may not have conducted destructive testing or chemical analysis on incoming materials and chemicals. TI and TI suppliers consider certain information to be proprietary, and thus CAS numbers and other limited information may not be available for release.

In no event shall TI's liability arising out of such information exceed the total purchase price of the TI part(s) at issue in this document sold by TI to Customer on an annual basis.

TAPE AND REEL INFORMATION

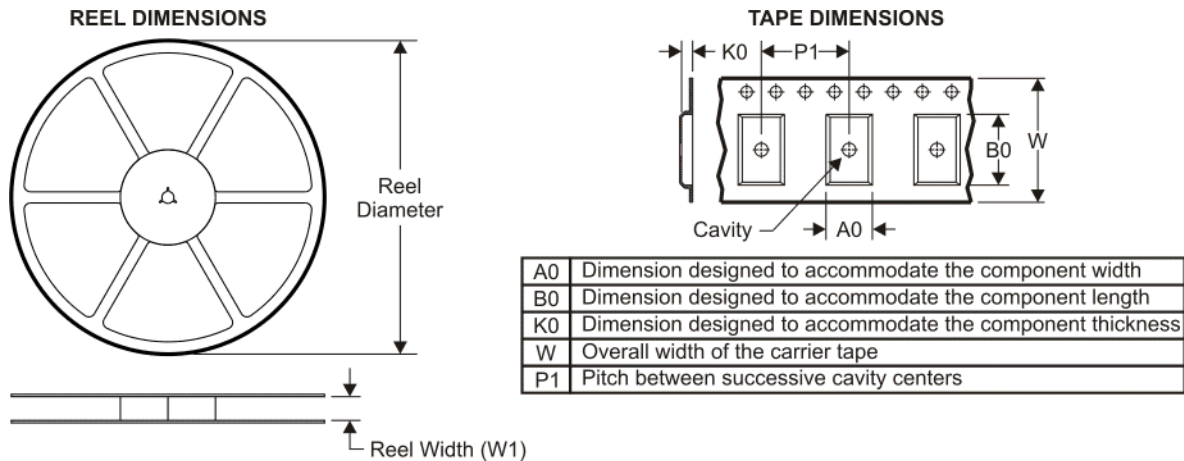

QUADRANT ASSIGNMENTS FOR PIN 1 ORIENTATION IN TAPE

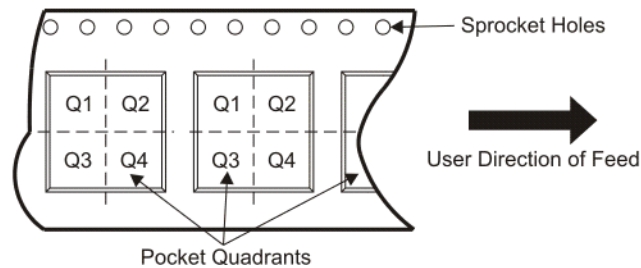

*All dimensions are nominal

Device	Package Type	Package Drawing	Pins	SPQ	Reel Diameter (mm)	Reel Width W1 (mm)	A0 (mm)	B0 (mm)	K0 (mm)	P1 (mm)	W (mm)	Pin1 Quadrant
SN74GTLPH32916KR	BGA MICROSTAR	GKF	114	1000	330.0	24.4	5.8	16.3	1.8	8.0	24.0	Q1
SN74GTLPH32916ZKFR	LFBGA	ZKF	114	1000	330.0	24.4	5.8	16.3	1.8	8.0	24.0	Q1

TAPE AND REEL BOX DIMENSIONS

*All dimensions are nominal

Device	Package Type	Package Drawing	Pins	SPQ	Length (mm)	Width (mm)	Height (mm)
SN74GTLPH32916KR	BGA MICROSTAR	GKF	114	1000	346.0	346.0	41.0
SN74GTLPH32916ZKFR	LFBGA	ZKF	114	1000	346.0	346.0	41.0

ZKF (R-PBGA-N114)

PLASTIC BALL GRID ARRAY

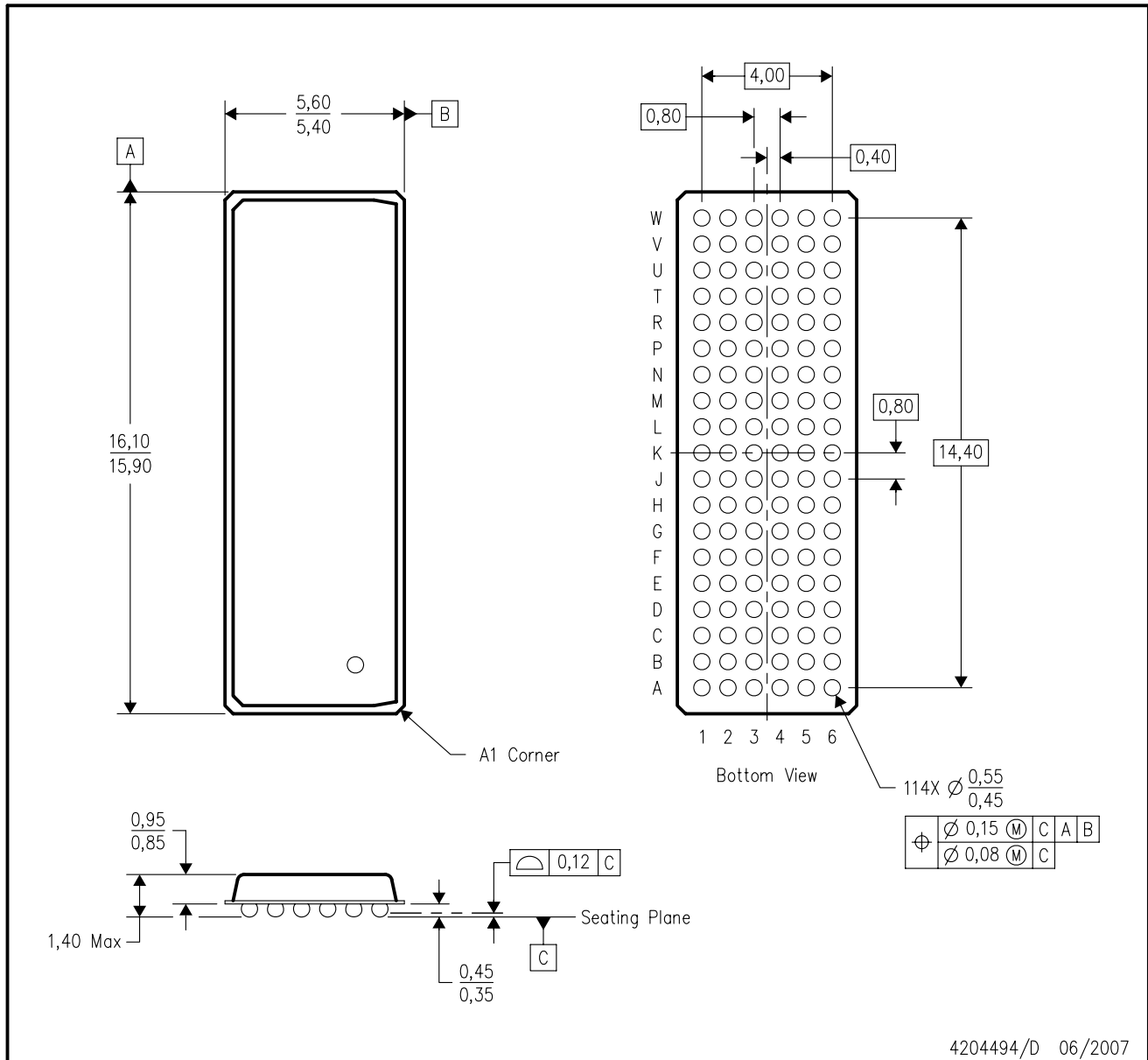

- NOTES:
- A. All linear dimensions are in millimeters. Dimensioning and tolerancing per ASME Y14.5M-1994.
 - B. This drawing is subject to change without notice.
 - C. Falls within JEDEC MO-205 variation DC.
 - D. This package is lead-free. Refer to the 114 GKF package (drawing 4188954) for tin-lead (SnPb).

GKF (R-PBGA-N114)

PLASTIC BALL GRID ARRAY

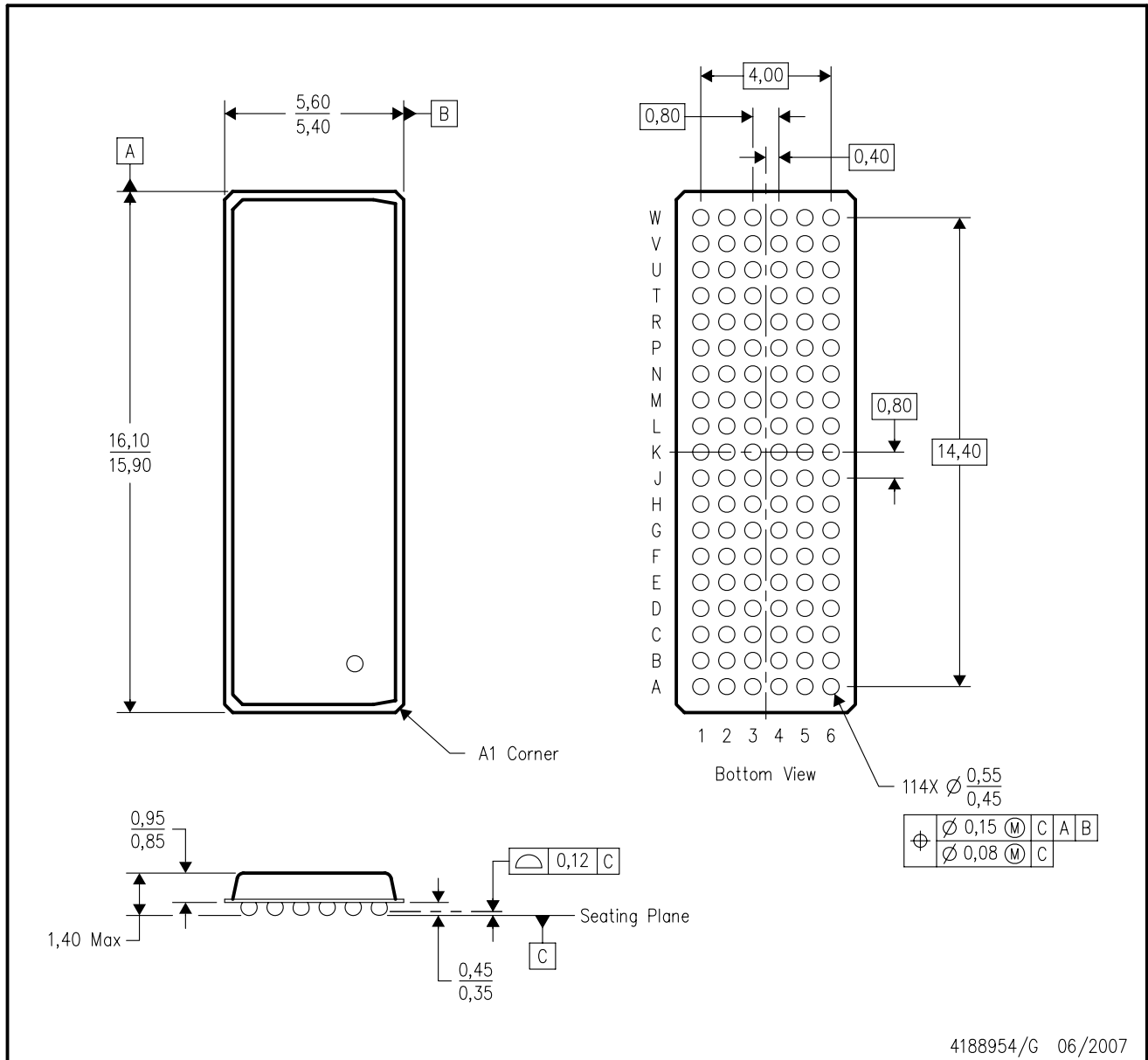

4188954/G 06/2007

- NOTES:
- A. All linear dimensions are in millimeters. Dimensioning and tolerancing per ASME Y14.5M-1994.
 - B. This drawing is subject to change without notice.
 - C. Falls within JEDEC MO-205 variation DC.
 - D. This package is tin-lead (SnPb). Refer to the 114 ZKF package (drawing 4204494) for lead-free.

IMPORTANT NOTICE

Texas Instruments Incorporated and its subsidiaries (TI) reserve the right to make corrections, modifications, enhancements, improvements, and other changes to its products and services at any time and to discontinue any product or service without notice. Customers should obtain the latest relevant information before placing orders and should verify that such information is current and complete. All products are sold subject to TI's terms and conditions of sale supplied at the time of order acknowledgment.

TI warrants performance of its hardware products to the specifications applicable at the time of sale in accordance with TI's standard warranty. Testing and other quality control techniques are used to the extent TI deems necessary to support this warranty. Except where mandated by government requirements, testing of all parameters of each product is not necessarily performed.

TI assumes no liability for applications assistance or customer product design. Customers are responsible for their products and applications using TI components. To minimize the risks associated with customer products and applications, customers should provide adequate design and operating safeguards.

TI does not warrant or represent that any license, either express or implied, is granted under any TI patent right, copyright, mask work right, or other TI intellectual property right relating to any combination, machine, or process in which TI products or services are used. Information published by TI regarding third-party products or services does not constitute a license from TI to use such products or services or a warranty or endorsement thereof. Use of such information may require a license from a third party under the patents or other intellectual property of the third party, or a license from TI under the patents or other intellectual property of TI.

Reproduction of TI information in TI data books or data sheets is permissible only if reproduction is without alteration and is accompanied by all associated warranties, conditions, limitations, and notices. Reproduction of this information with alteration is an unfair and deceptive business practice. TI is not responsible or liable for such altered documentation. Information of third parties may be subject to additional restrictions.

Resale of TI products or services with statements different from or beyond the parameters stated by TI for that product or service voids all express and any implied warranties for the associated TI product or service and is an unfair and deceptive business practice. TI is not responsible or liable for any such statements.

TI products are not authorized for use in safety-critical applications (such as life support) where a failure of the TI product would reasonably be expected to cause severe personal injury or death, unless officers of the parties have executed an agreement specifically governing such use. Buyers represent that they have all necessary expertise in the safety and regulatory ramifications of their applications, and acknowledge and agree that they are solely responsible for all legal, regulatory and safety-related requirements concerning their products and any use of TI products in such safety-critical applications, notwithstanding any applications-related information or support that may be provided by TI. Further, Buyers must fully indemnify TI and its representatives against any damages arising out of the use of TI products in such safety-critical applications.

TI products are neither designed nor intended for use in military/aerospace applications or environments unless the TI products are specifically designated by TI as military-grade or "enhanced plastic." Only products designated by TI as military-grade meet military specifications. Buyers acknowledge and agree that any such use of TI products which TI has not designated as military-grade is solely at the Buyer's risk, and that they are solely responsible for compliance with all legal and regulatory requirements in connection with such use.

TI products are neither designed nor intended for use in automotive applications or environments unless the specific TI products are designated by TI as compliant with ISO/TS 16949 requirements. Buyers acknowledge and agree that, if they use any non-designated products in automotive applications, TI will not be responsible for any failure to meet such requirements.

Following are URLs where you can obtain information on other Texas Instruments products and application solutions:

Products

Amplifiers	amplifier.ti.com
Data Converters	dataconverter.ti.com
DLP® Products	www.dlp.com
DSP	dsp.ti.com
Clocks and Timers	www.ti.com/clocks
Interface	interface.ti.com
Logic	logic.ti.com
Power Mgmt	power.ti.com
Microcontrollers	microcontroller.ti.com
RFID	www.ti-rfid.com
RF/IF and ZigBee® Solutions	www.ti.com/lprf

Applications

Audio	www.ti.com/audio
Automotive	www.ti.com/automotive
Broadband	www.ti.com/broadband
Digital Control	www.ti.com/digitalcontrol
Medical	www.ti.com/medical
Military	www.ti.com/military
Optical Networking	www.ti.com/opticalnetwork
Security	www.ti.com/security
Telephony	www.ti.com/telephony
Video & Imaging	www.ti.com/video
Wireless	www.ti.com/wireless

Mailing Address: Texas Instruments, Post Office Box 655303, Dallas, Texas 75265
Copyright © 2009, Texas Instruments Incorporated