

PRODUCT NUMBER
SEE TABLE

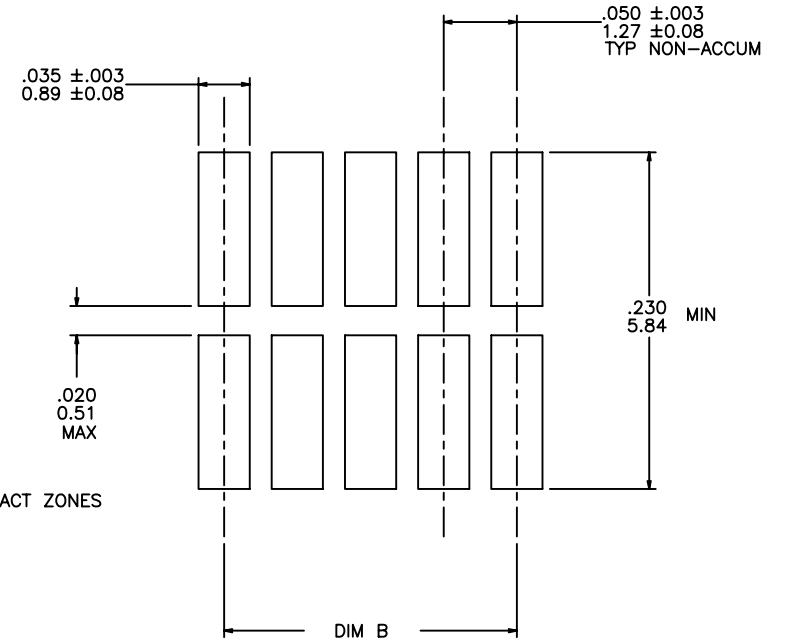
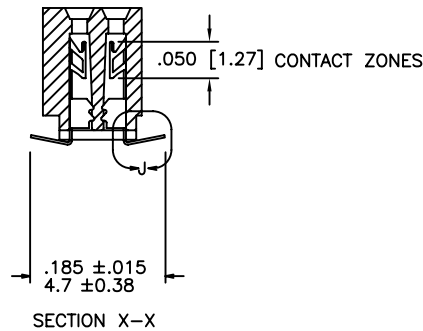
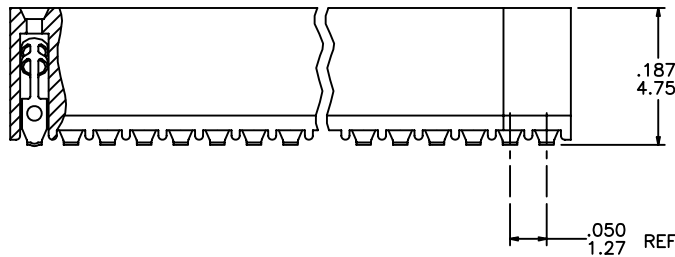
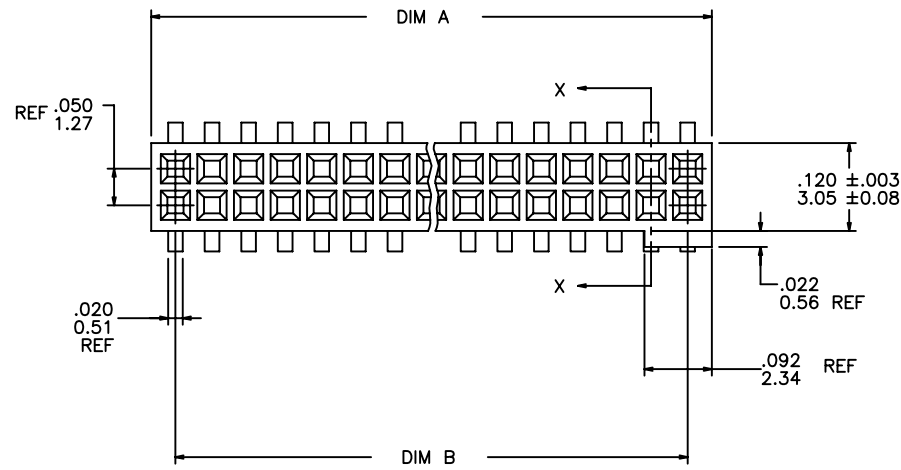
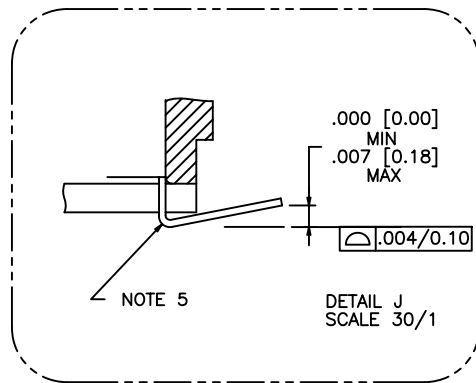

FIGURE "A"
RECOMMENDED PCB
MOUNTING PAD PATTERN



mat'l. code		surface		tolerance	projection	product family	
-		ISO 1302 ✓		ISO 406	INCH/MM	RIBCAGE	
		tolerances unless otherwise specified		ISO 1101		title	
ltr	ecn	nldr	date	angles	linear	.050 CC VERT. C.C. ASS'Y. SUR. MOUNT-POL.	
AC	ELX-N-16109	GM	10/15/13		.XX±.01/0.3	scale 4:1	
V	M05-0123	MHT	06/06/05		.XXX±.005/0.13	dwg no	
W	M06-0225	ERE	06/12/06	0°±2'	.XXXX±.0020/0.051	sheet 1 of 3 size	
X	M06-0370	MHT	09/26/06	dr	D. SHEAFFER	87022 A3	
Y	M08-0053	MHT	02/27/08	enr	J. OSWALD	type	
AA	M09-0058	CMR	4/06/09	chr	J. OSWALD	Product Customer Drawing	
AB	ELX-N-010200	YO	02/07/12	app	J. OSWALD		
sheet	revision	AC	AC	AC			
index	sheet	1	2	3			

PRODUCT NO. NOTE 3, 9	SIZE	DIM A	DIM B	SPECIAL PACKAGING	TAPE WIDTH PITCH	PCS. PER REEL
87022-X05	2 X 5	.266/6.76	.200/5.08	NOTE 7	24mm 12mm	750
-X10	2 X 10	.516/13.11	.450/11.43	NOTE 7	24mm 12mm	750
-X15	2 X 15	.766/19.46	.700/17.78	NOTE 7	44mm 12mm	500
-X20	2 X 20	1.016/25.81	.950/24.13	NOTE 7	44mm 12mm	500
-X25	2 X 25	1.266/32.16	1.200/30.48	NOTE 7	44mm 12mm	500
-X30	2 X 30	1.516/38.51	1.450/36.83	NO	—	—
-X35	2 X 35	1.766/44.86	1.700/43.18	NO	—	—
-X40	2 X 40	2.016/51.21	1.950/49.53	NO	—	—
-X45	2 X 45	2.266/57.56	2.200/55.88	NO	—	—
87022-X50	2 X 50	2.516/63.91	2.450/63.23	NO	—	—
87022-X25 MIL.	2 X 25	1.266/32.16	1.200/30.48	NO	—	—

NOTE 6

- LEAD TIPS TO BE ABOVE HEEL, UP TO .007/0.18 MAX. COPLANARITY TO BE MEASURED AT LOWEST POINT (HEEL).
- SOLDERTAIL SHALL BE FINISHED IN ACCORDANCE WITH MIL-STD-1276. HOT SOLDER DIP (FINISH 51) OR FUSED (REFLOWED) TIN LEAD PLATE (FINISH 34). 100u"/2.54u MIN.

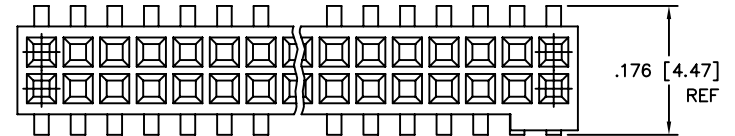

NOTES :

- HOUSING MATERIAL :
LCP GLASS FILLED . FLAME RETARDANT PER UL94V-0.
COLOR : NATURAL
- TERMINAL MATERIAL : BeCu
- TERMINAL PLATING :
3.1 87022-6XX
30u"/.76u MIN GOLD OR GXT OVER Ni ON CONTACT ZONES.
100u"/2.54u MIN Sn. OVER Ni IN SOLDERING ZONES.
OTHERWISE GOLD FLASH OR UNPLATED. MATTE TIN FINISH AT SOLDERING ZONE.
3.2 87022-1XX
30u"/.76u MIN GOLD OVER Ni ON CONTACT ZONES.
GOLD FLASH OVER Ni IN OTHER ALL ZONES.
- APPLICATION INFORMATION:
A. RECOMMENDED MOUNTING PAD PATTERN IS SHOWN IN FIGURE "A".
B. MATING PINS TO BE .0176/0.447 TO .0181/0.459 DIA.
C. MATING PIN TIPS TO BE IN TRUE POSITION TO MATING GRID WITHIN .008/0.20 DIA.
D. SUGGESTED MATING PIN LENGTH .130/3.30 ±.010/0.25.

- ADD "TR" TO END OF DASH NUMBER FOR TAPE AND REEL PACKAGING WITH CAP. TOOLED ONLY FOR NOTED CONNECTORS.
- ADD "CT" TO END OF DASH NUMBER FOR CONNECTOR WITH VACUUM CAP IN TUBE.
- ADD "LF" SUFFIX AT THE END OF PART NUMBER FOR LEAD FREE OPTION.
- THIS PRODUCT MEETS EUROPEAN UNION DIRECTIVES AND OTHER COUNTRY REGULATION AS DESCRIBED IN GS-22-008.
- THE HOUSING WILL WITHSTAND EXPOSURE TO 260°C PEAK TEMPERATURE FOR 20 SECONDS IN A CONVECTION, INFRA-RED OR VAPOR PHASE REFLOW OVEN. SEE APPLICATION NOTES/PROCEDURES IF THEY ARE AVAILABLE.
- PRODUCT SPEC PER BUS-12-087.

mat'l. code		surface		tolerance	projection	product family	
-		ISO 1302 ✓		ISO 406	INCH/MM	RIBCAGE	
				ISO 1101		title	
ltr	ecn	no	dr	date		tolerances unless otherwise specified	
AC				angles	linear	.050 CC VERT. C.C. ASS'Y. SUR. MOUNT-POL.	
				0°±2'	.XX±.01/0.3	scale 4:1	
					.XXX±.005/0.13	dwg no	
					.XXX±.0020/0.051	sheet 2 of 3 size	
				dr	D. SHEAFFER	87022	
				enr	J. OSWALD	A3	
				chr	J. OSWALD	type	
				app	J. OSWALD	Product Customer Drawing	
sheet	revision						
index	sheet						

PRODUCT NUMBER
SEE TABLE

UNREELING
DIRECTION

REFERENCE ONLY

TAPE WIDTH'S 32mm AND ABOVE HAS BOTH FEED TRACKS,
BELOW 32mm HAS TOP FEED TRACK ONLY.

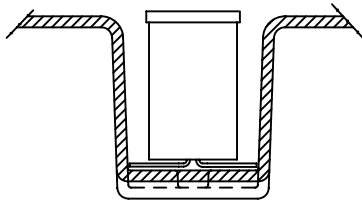
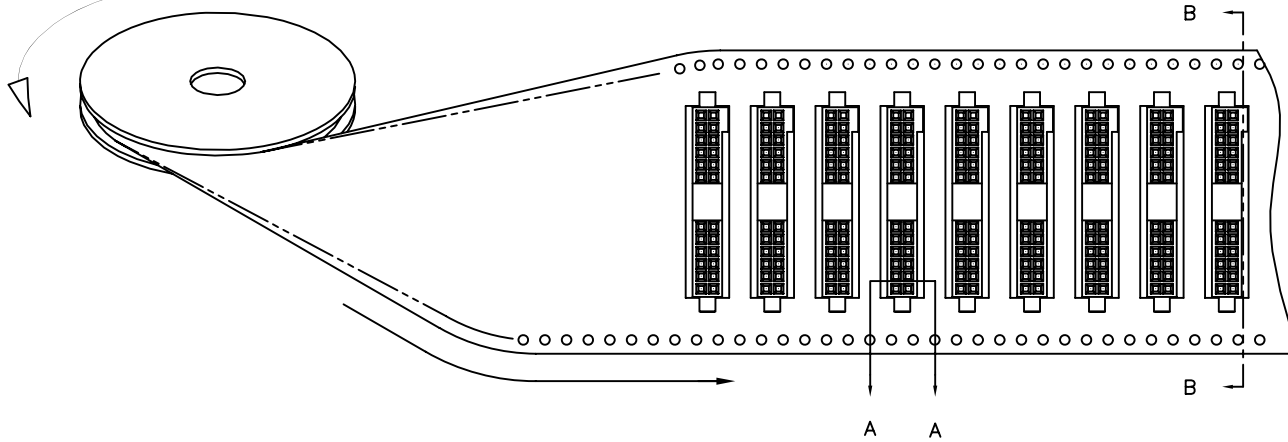

SECTION A-A

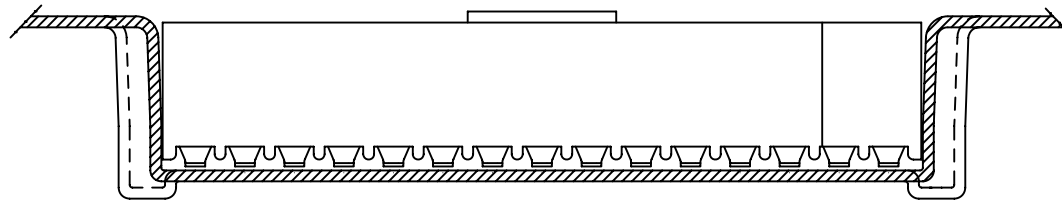

SECTION B-B



FCIconnect.com

Copyright FCI

mat'l. code		surface		tolerance		projection		product family	
-		ISO 1302 ✓		ISO 406		⊕		RIBCAGE	
tr		ecn no dr date		tolerances unless otherwise specified		INCH/MM		title	
AC				angles		linear		.050 CC VERT. C.C. ASS'Y. SUR. MOUNT-POL.	
				0°±2'		.XX±.01/0.3		scale 4:1	
				dr D. SHEAFFER		.XXX±.005/0.13		dwg no	
				enr J. OSWALD		.XXXX±.0020/0.051		sheet 3 of 3 size	
				chr J. OSWALD				87022 A3	
				app J. OSWALD				type Product Customer Drawing	
sheet		revision							
index		sheet							

