

25-Bit 1:1 or 14-Bit 1:2 Configurable Registered Buffer

Features

- PI74 SSTU32864 is designed for low-voltage operation, $V_{DD} = 1.8V$
- Supports Low Power Standby Operation
- All Inputs are SSTL_18 Compatible, except \overline{RST} , C0, C1, which are LVCMOS.
- Output drivers are optimized to drive DDR-II DIMM loads
- Designed for DDR Memory
- Packaging (Pb-free & Green available):
-96 Ball LFBGA (NB)

Description

Pericom Semiconductor's PI74SSTU32864 logic circuit is produced using advanced CMOS technology. This 25-Bit 1:1 or 14-Bit 1:2 configurable registered buffer is designed for 1.7V to 1.9V V_{DD} operation.

All clock and data inputs are compatible with the JEDEC standard for SSTL_18. The control inputs are LVCMOS. All outputs are 1.8V LVCMOS drivers that have been optimized to drive the DDR-II DIMM load.

The SSTU32864 operates from a differential clock (CK and \overline{CK}). Data is registered at the crossing of CK going high, and \overline{CK} going low.

The C0 input controls the pinout configuration of the 1:2 pinout from A configuration (when LOW) to B configuration (when HIGH). The C1 input controls the pinout configuration for 25-Bit 1:1 (when LOW) to 14-Bit 1:2 (when HIGH).

The device supports low-power standby operation. When the reset input (\overline{RST}) is low, the differential input receivers are disabled and undriven (floating) data, clock and reference voltage (V_{REF}) inputs are allowed. In addition, when \overline{RST} is low, all registers are reset, and all outputs are forced low. The LVCMOS \overline{RST} and Cn inputs must always be held at a valid logic high or low level.

To ensure defined outputs from the register before a stable clock has been supplied, \overline{RST} must be held in the low state during power up.

In the DDR-II RDIMM application, \overline{RST} is specified to be completely asynchronous with respect to CK and \overline{CK} . Therefore, no timing relationship can be guaranteed between the two. When entering reset, the register will be cleared and the outputs will be driven low quickly, relative to the time to disable the differential input receivers. However, when coming out of reset, the register will become active quickly, relative to the time to enable the differential input receivers.

As long as the data inputs are low, and the clock is stable during the time from the low-to-high transition of \overline{RST} until the input receivers are fully enabled, the design of the SSTU32864 must ensure that the outputs remain low, thus ensuring no glitches on the output.

The device monitors both \overline{DCS} and \overline{CSR} inputs and will gate the Qn outputs from changing states when both \overline{DCS} and \overline{CSR} inputs are high. If either \overline{DCS} or \overline{CSR} input is low, the Qn outputs will function normally. The \overline{RST} input has priority over the \overline{DCS} and \overline{CSR} control will force the outputs low. If the \overline{DCS} control functionality is not desired, then the CSR input can be hardwired to ground, in which case, the set-up time requirement for \overline{DCS} would be the same as for the other D data inputs.

Block Diagram 1:2 Mode (Positive Logic)

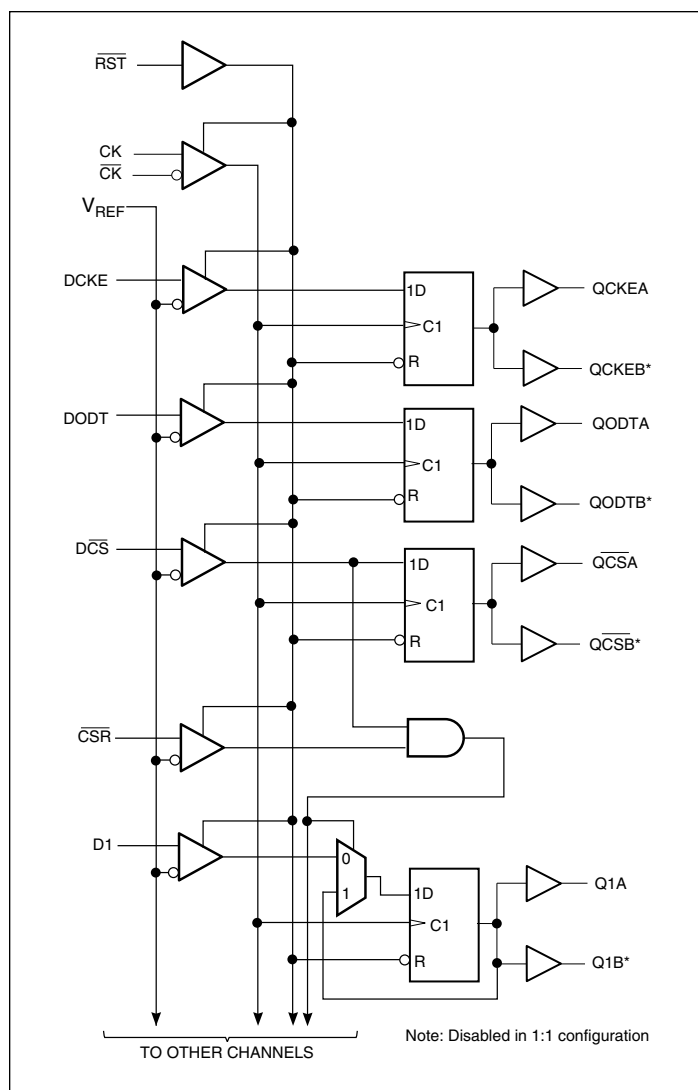

Pin Configuration 1:1 Register (C0 = 0, C1 = 0)

	1	2	3	4	5	6
A	DCKE	NC	V _{REF}	V _{DD}	QCKE	NC
B	D2	D15	GND	GND	Q2	Q15
C	D3	D16	V _{DD}	V _{DD}	Q3	Q15
D	DODT	NC	GND	GND	QODT	NC
E	D5	D17	V _{DD}	V _{DD}	Q5	Q17
F	D6	D18	GND	GND	Q6	Q18
G	NC	$\overline{\text{RST}}$	V _{DD}	V _{DD}	C1	C0
H	CK	$\overline{\text{DCS}}$	GND	GND	$\overline{\text{QCS}}$	NC
J	$\overline{\text{CK}}$	$\overline{\text{CSR}}$	V _{DD}	V _{DD}	ZOH	ZOL
K	D8	D19	GND	GND	Q8	Q19
L	D9	D20	V _{DD}	V _{DD}	Q9	Q20
M	D10	D21	GND	GND	Q10	Q21
N	D11	D22	V _{DD}	V _{DD}	Q11	Q22
P	D12	D23	GND	GND	Q12	Q23
R	D13	D24	V _{DD}	V _{DD}	Q13	Q24
T	D14	D25	V _{REF}	V _{DD}	Q14	Q25

Pin Configuration 1:2 Register (C0 = 0, C1 = 1)

	1	2	3	4	5	6
A	DCKE	NC	V _{REF}	V _{DD}	QCKEA	QCKEB
B	D2	NC	GND	GND	Q2A	Q2B
C	D3	NC	V _{DD}	V _{DD}	Q3A	QODTB
D	DODT	NC	GND	GND	QODTA	Q4B
E	D5	NC	V _{DD}	V _{DD}	Q5A	Q5B
F	D6	NC	GND	GND	Q6A	Q6B
G	NC	$\overline{\text{RST}}$	V _{DD}	V _{DD}	C1	C0
H	CK	$\overline{\text{DCS}}$	GND	GND	$\overline{\text{QCSA}}$	$\overline{\text{QCSB}}$
J	$\overline{\text{CK}}$	$\overline{\text{CSR}}$	V _{DD}	V _{DD}	ZOH	ZOL
K	D8	NC	GND	GND	Q8A	Q8B
L	D9	NC	V _{DD}	V _{DD}	Q9A	Q9B
M	D10	NC	GND	GND	Q10A	Q10B
N	D11	NC	V _{DD}	V _{DD}	Q11A	Q11B
P	D12	NC	GND	GND	Q12A	Q12B
R	D13	NC	V _{DD}	V _{DD}	Q13A	Q13B
T	D14	NC	V _{REF}	V _{DD}	Q14A	Q14B

Pin Configuration 1:2 Register (C0 = 1, C1 = 1)

	1	2	3	4	5	6
A	D1	NC	V _{REF}	V _{DD}	Q1A	QB
B	D2	NC	GND	GND	Q2A	Q2B
C	D3	NC	V _{DD}	V _{DD}	Q3A	Q3B
D	D4	NC	GND	GND	Q4A	Q4B
E	D5	NC	V _{DD}	V _{DD}	Q5A	Q5B
F	D6	NC	GND	GND	Q6A	Q6B
G	NC	$\overline{\text{RST}}$	V _{DD}	V _{DD}	C1	C0
H	CK	$\overline{\text{DCS}}$	GND	GND	$\overline{\text{QCSA}}$	$\overline{\text{QCSB}}$
J	$\overline{\text{CK}}$	$\overline{\text{CSR}}$	V _{DD}	V _{DD}	ZOH	ZOL
K	D8	NC	GND	GND	Q8A	Q8B
L	D9	NC	V _{DD}	V _{DD}	Q9A	Q9B
M	D10	NC	GND	GND	Q10A	Q10B
N	DODT	NC	V _{DD}	V _{DD}	QODTA	QODTB
P	D12	NC	GND	GND	Q12A	Q12B
R	D13	NC	V _{DD}	V _{DD}	Q13A	Q13B
T	DCKE	NC	V _{REF}	V _{DD}	QCKEA	QCKEB

NB 96-ball LFBGA (MO-205CC) Top View

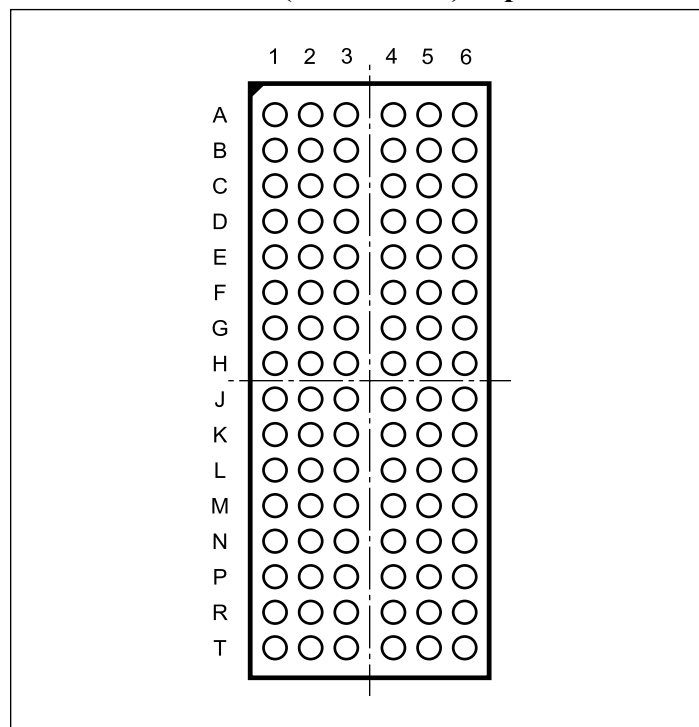

Terminal Functions

Name	Description	Characteristics
GND	Ground	Ground Input
V _{DD}	Power Supply	1.8V nominal
V _{REF}	Input Reference Voltage	0.9V nominal
Z _{OH}	Reserved for future use	Input
Z _{OL}	Reserved for future use	Input
CK	Positive master clock input	Differential Clock input
$\overline{\text{CK}}$	Negative master clock input	Differential Clock input
C0, C1	Configuration control inputs	LVC MOS inputs
RST	Asynchronous reset input - resets registers and disables V _{REF} data and clock differential - input receivers	LVC MOS inputs
$\overline{\text{CSR}}$, $\overline{\text{DCS}}$	Chip select inputs disables D1-D24 outputs switching when both inputs are high	SSTL_18 input
D1, D25	Data input - clocked in on the crossing of the rising edge of CK and the falling edge of $\overline{\text{CK}}$	SSTL_18 input
DODT	The outputs of this register bit will not be suspended by the $\overline{\text{DCS}}$ and $\overline{\text{CSR}}$ control	SSTL_18 input
DCKE	The outputs of this register bit will not be suspended by the $\overline{\text{DCS}}$ and $\overline{\text{CSR}}$ control	SSTL_18 input
Q1-Q25	Data outputs that are suspended by the $\overline{\text{DCS}}$ and $\overline{\text{CSR}}$ control	1.8V CMOS
$\overline{\text{QCS}}$	Data output that will not be suspended by the $\overline{\text{DCS}}$ and $\overline{\text{CSR}}$ control	1.8V CMOS
QODT	Data output that will not be suspended by the $\overline{\text{DCS}}$ and $\overline{\text{CSR}}$ control	1.8V CMOS
QCKE	Data output that will not be suspended by the $\overline{\text{DCS}}$ and $\overline{\text{CSR}}$ control	1.8V CMOS

Function Table (each flip flop)

Inputs						Outputs		
$\overline{\text{RST}}$	$\overline{\text{DCS}}$	$\overline{\text{CSR}}$	CK	$\overline{\text{CK}}$	Dn, DODT, DCKE	Qn	$\overline{\text{QCS}}$	QODT, QCKE
H	L	L	↑	↓	L	L	L	L
H	L	L	↑	↓	H	H	L	H
H	L	L	L or H	L or H	X	Q0	Q0	Q0
H	L	H	↑	↓	L	L	L	L
H	L	H	↑	↓	H	H	L	H
H	L	H	L or H	L or H	X	Q0	Q0	Q0
H	H	L	↑	↓	L	L	H	L
H	H	L	↑	↓	H	H	H	H
H	H	L	L or H	L or H	X	Q0	Q0	Q0
H	H	H	↑	↓	L	Q0	H	L
H	H	H	↑	↓	H	Q0	H	H
H	H	H	L or H	L or H	X	Q0	Q0	Q0
L	X or floating	X or floating	X or floating	X or floating	X or floating	L	L	L

Maximum Ratings

(Above which the useful life may be impaired. For user guidelines, not tested.)

Storage Temperature	-65°C to +150°C
Supply Voltage Range, V_{DD}	-0.5V to 2.5V
Input Voltage Range, V_I : (See Notes 2 and 3):	-0.5V to 2.5V
Output Voltage Range, V_O (See Notes 2 and 3)....	-0.5V to $V_{DD} + 0.5V$
Input Clamp current, I_{IK} ($V_I < 0$ or $V_I = V_{DD}$)	-50mA
Output Clamp current, I_{OK} ($V_O < 0$ or $V_O > V_{DD}$).....	±50mA
Continuous Output Current, I_O ($V_O = 0$ to V_{DD})	±50mA
Continuous Current through each V_{DD} or GND.....	±100mA

Notes:

1. Stresses greater than those listed under MAXIMUM RAININGS may cause permanent damage to the device. This is a stress rating only and functional operation of the device at these or any other conditions above those indicated in the operational sections of this specification is not implied. Exposure to absolute maximum rating conditions for extended periods may affect reliability.
2. The input and output negative-voltage ratings may be exceeded if the input and output clamp-current ratings are observed.
3. This value is limited to 2.5V maximum

Recommended Operating Conditions⁽¹⁾

Parameters	Description	Min.	Nom.	Max.	Units	
V_{DD}	Supply Voltage	1.7		1.9	V	
V_{REF}	Reference Voltage	$0.49 \times V_{DD}$	$0.50 \times V_{DD}$	$0.51 \times V_{DD}$		
V_{TT}	Termination Voltage	$V_{REF} - 40mA$	V_{REF}	$V_{REF} - 40mA$		
V_I	Input Voltage	0		V_{DD}		
V_{IH}	AC High - Level Input Voltage	$V_{REF} - 250mV$				
V_{IL}	AC Low- Level Input Voltage			$V_{REF} - 250mV$		
V_{IH}	DC High - Level Input Voltage	$V_{REF} - 125mV$				
V_{IL}	DC Low- Level Input Voltage			$V_{REF} - 125mV$		
V_{IH}	High Level Input Voltage	$0.65 \times V_{DD}$				
V_{IL}	Low Level Input Voltage			$0.35 \times V_{DD}$		
V_{ICR}	Common-mode input Voltage	0.675		1.125		
V_{ID}	Differential Input Voltage	600				mV
I_{OH}	High-Level Output Current			-8		mA
I_{OL}	Low-Level Output Current			-8		
T_A	Operating Free-air Temperature	0		70	°C	

Notes:

1. The \overline{RST} and Cn inputs of the device must be held at valid levels (not floating) to ensure proper device operation. The differential inputs must not be floating, unless \overline{RST} is low.

Electrical Characteristics Over Recommended Operating Free Air Temperature range

Parameters	Description	Test Conditions	V _{DD}	Min.	Nom.	Max.	Units
V _{OH}		I _{OH} = -6 mA	1.7V	1.2			V
V _{OL}		I _{OL} = 6 mA	1.7V			0.5	
I _I	All inputs	V _I = V _{DD} or GND				±5	μA
I _{DD}	Static Stand-by	$\overline{\text{RST}} = \text{GND}$	1.9V			100	
	Static Operating	$\overline{\text{RST}} = \text{V}_{\text{DD}}, V_{\text{I}} = V_{\text{IH(AC)}} \text{ or } V_{\text{IL(AC)}}$				40	mA
I _{DDD}	Dynamic Operating Clock only	$\overline{\text{RST}} = \text{V}_{\text{DD}}, V_{\text{I}} = V_{\text{IH(AC)}}, \text{ or } V_{\text{IL(AC)}}$ CK and $\overline{\text{CK}}$ switching 50% duty cycle	I _O = 0	1.8V	28		μA/ clock MHz
	Dynamic Operating - per each data input, 1:1 mode	$\overline{\text{RST}} = \text{V}_{\text{DD}}, V_{\text{I}} = V_{\text{IH(AC)}}, \text{ or } V_{\text{IL(AC)}}$ CK and $\overline{\text{CK}}$ switching 50% duty cycle. One data input switching at half clock frequency, 50% duty cycle			18		μA/ clock MHz data input
	Dynamic Operating - per each data input, 1:2 mode	$\overline{\text{RST}} = \text{V}_{\text{DD}}, V_{\text{I}} = V_{\text{IH(AC)}}, \text{ or } V_{\text{IL(AC)}}$ CK and $\overline{\text{CK}}$ switching 50% duty cycle. One data input switching at half clock frequency, 50% duty cycle			36		
C _I	Data inputsp	V _I = V _{REF} ±250mV		2.5		3.5	pF
	CK and $\overline{\text{CK}}$	V _{ICR} = 0.9V, V _{ID} = 600mV		2		3	
	$\overline{\text{RST}}$	V _I = V _{DD} or GND			2.5		

Notes:

- The vendor must supply this value for full device description.

Timing Requirements Over Recommended Operating Free Air Temperature range (See Figure 1)

Parameter	Description	Min.	Max	Units
f _{clock}	Clock frequency		270	MHz
t _w	Pulse Duration, CK, $\overline{\text{CK}}$, High or low	1		ns
t _{act} ⁽¹⁾	Differential inputs active time ⁽¹⁾		10	
t _{inact} ⁽¹⁾	Differential inputs inactive time ⁽²⁾		15	
t _{su}	Setup time	D $\overline{\text{CS}}$ before CK \uparrow , $\overline{\text{CK}}\downarrow$, $\overline{\text{CSR}}$ high	0.7	
		D $\overline{\text{CS}}$ before CK \uparrow , $\overline{\text{CK}}\downarrow$, $\overline{\text{CSR}}$ low	0.5	
		$\overline{\text{CSR}}$ DODT, CKE and data before $\overline{\text{CK}}\uparrow$, CK \downarrow	0.5	
t _h	Hold Time	D $\overline{\text{CS}}$, $\overline{\text{CSR}}$ DODT, CKE and data before CK \uparrow , $\overline{\text{CK}}\downarrow$	0.5	

Notes

- This parameter is not necessarily production tested.
- Data and V_{REF} inputs must be a low minimum time of t_{act} max, after RST is taken high.
- Data and clock inputs must be held at valid levels (not floating) a minimum time of t_{inact} max after RST is taken low.

Switching Characteristics Over Recommended Operating Free Air Temperature range (See Figure 1)

Parameters	From (Input)	To (Output)	$V_{DD} = 1.8V \pm 0.1V$		Units
			Min.	Max.	
f_{max}			270		MHz
t_{pdm}	CK and \overline{CK}	Q	1.41 ⁽³⁾	2.15 ⁽³⁾	ns
t_{pdmss} (simultaneous switching) ^(1, 2)	CK and \overline{CK}	Q		2.35 ⁽³⁾	
t_{RPHL}	\overline{RST}	Q	0	3	

Note:

1. Includes 350ps test load transmission-line delay.
2. This parameter is not necessarily production tested.
3. For reference only. Final values to be determined.

Output Edge Rates Over Recommended Operating Free Air Temperature range (See Figure 2)

Parameters	$V_{DD} = 1.8V \pm 0.1V$		Units
	Min.	Max.	
dV/dt_r	1	4	V/ns
dV/dt_f	1	4	
$dV/dt^{(1)}$		1	

Notes:

1. Difference between dV/dt_r (rising edge rate) and dV/dt_f (falling edge rate).

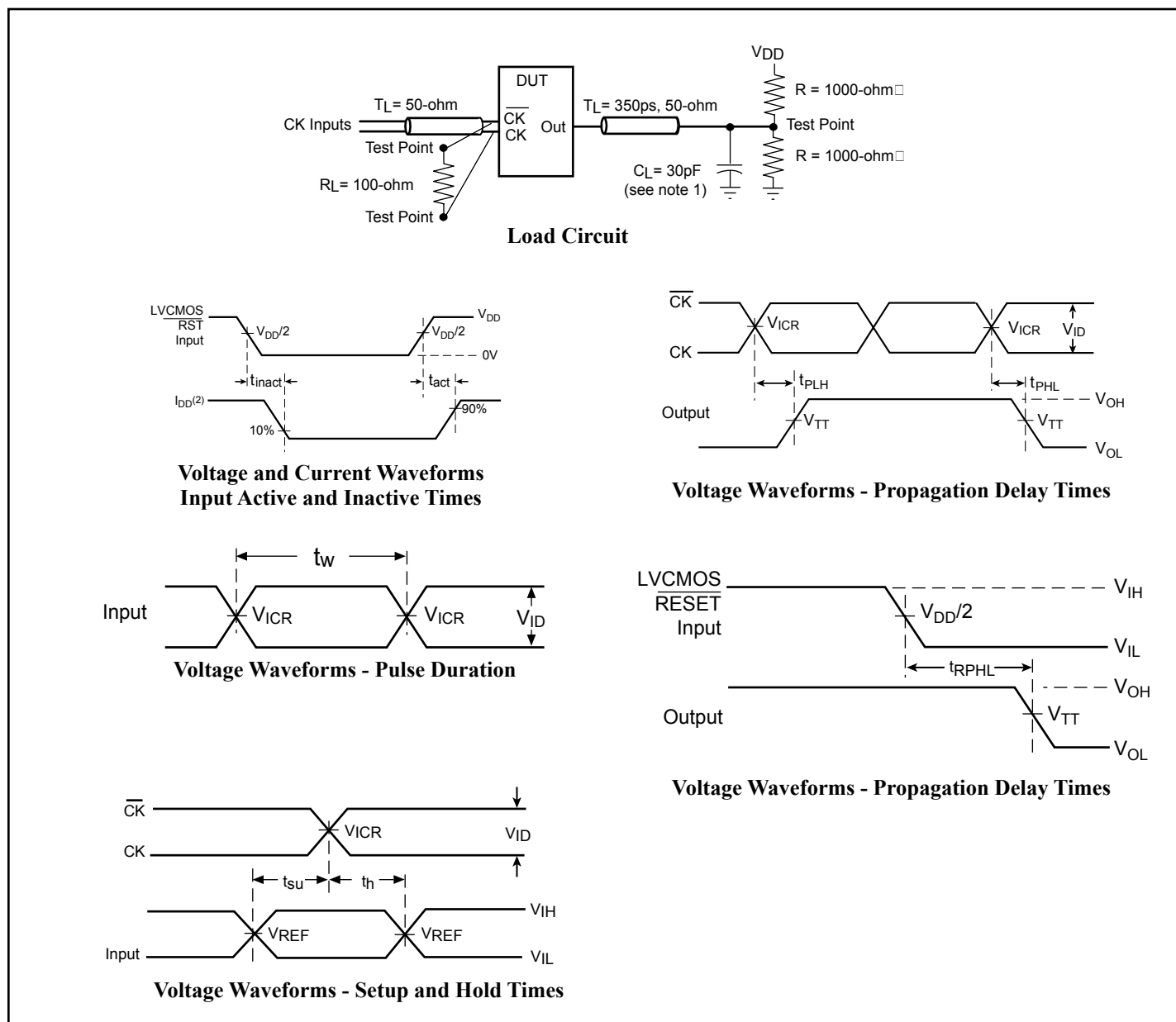
Test Circuit and Switching Waveforms

Figure 1. Parameter Measurement Information ($V_{DD} = 1.8V \pm 0.1V$)
Notes:

1. C_L includes probe and jig capacitance
2. I_{DD} tested with clock and data inputs held at V_{DD} or GND and $I_O = 0mA$
3. All input pulses are supplied by generators having the following characteristics: Pulse Repetition Rate ≥ 10 MHz, $Z_O = 50\Omega$, input slew rate = $1V/ns \pm 20\%$ (unless otherwise specified).
4. The outputs are measured one at a time with one transition per measurement.
5. $V_{REF} = V_{DD}/2$
6. $V_{IH} = V_{REF} + 250mV$ (ac voltage levels) for differential inputs. $V_{IH} = V_{DD}$ for LVC MOS input.
7. $V_{IL} = V_{REF} - 250mV$ (ac voltage levels) for differential inputs. $V_{IL} = GND$ for LVC MOS input.
8. $V_{ID} = 600mV$
9. t_{PLH} and t_{PHL} are the same as t_{pdm} .

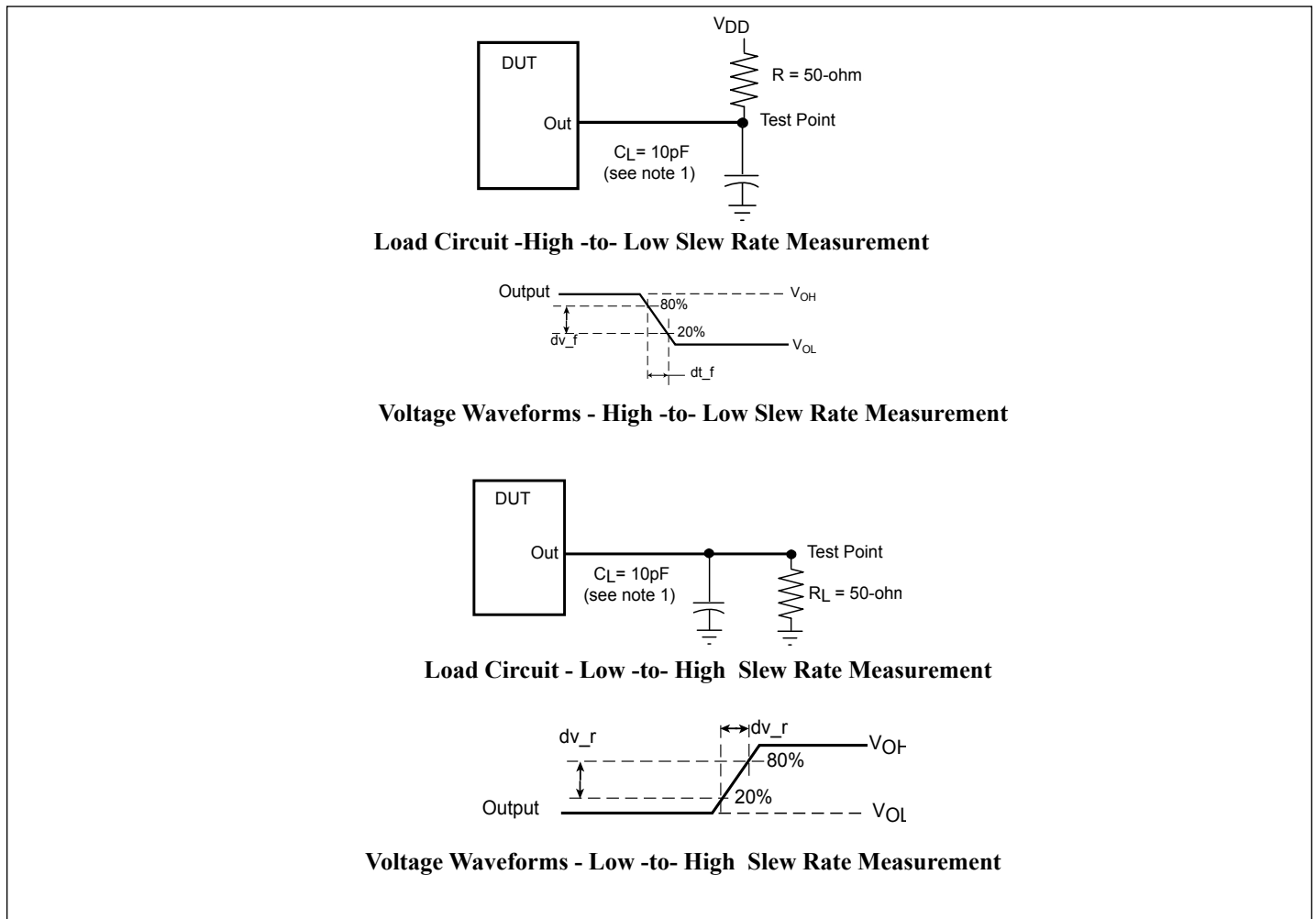
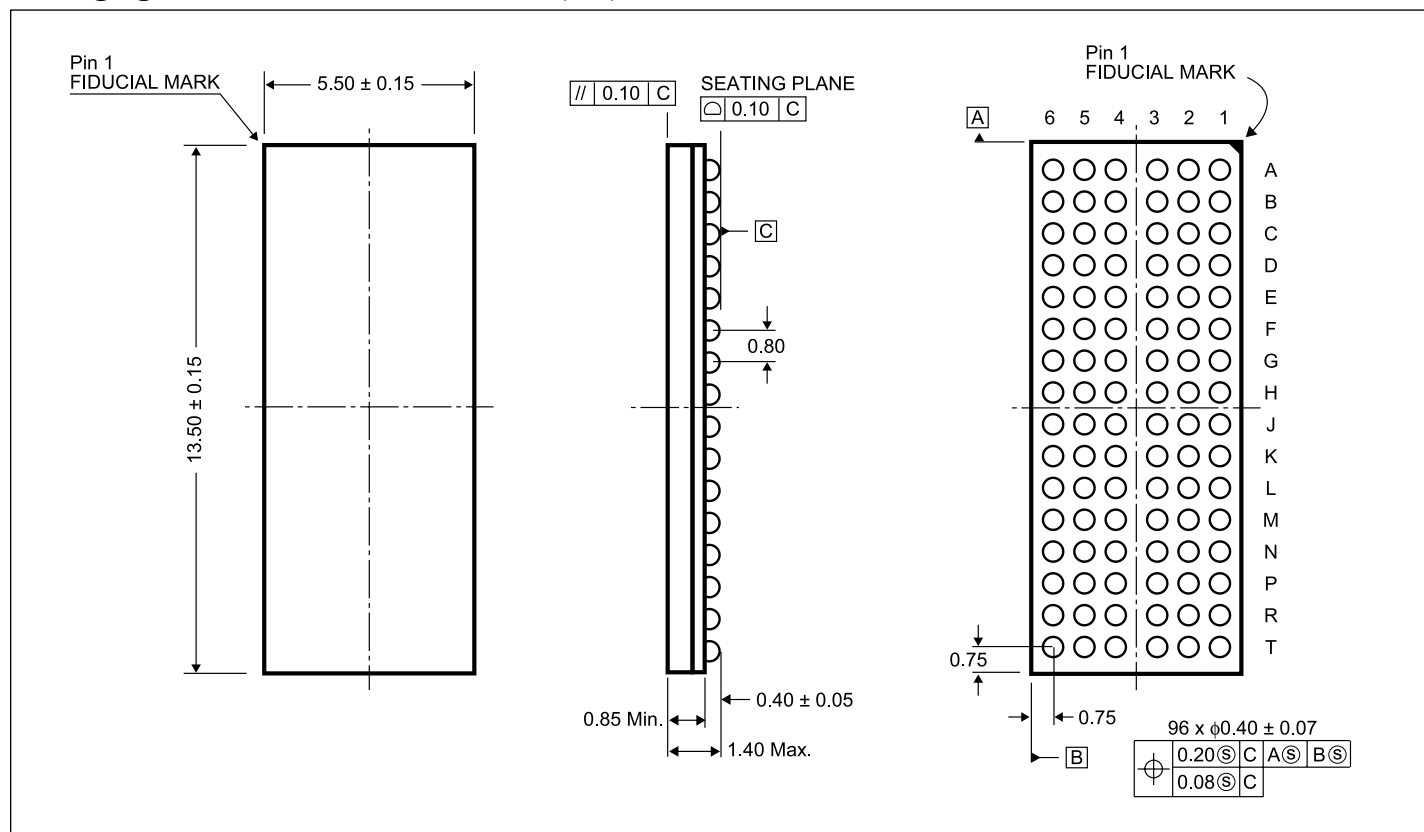

Figure 2. Output Slew-Rate Measurement Information ($V_{DD} = 1.8V \pm 0.1V$)

Notes:

1. C_L includes probe and jig capacitance
2. All input pulses are supplied by generators having the following characteristics: $PRR \leq 10MHz$, $ZO = 50\Omega$, input slew rate = $1 V/ns \pm 20\%$ (unless otherwise specified).

Packaging Mechanical: 96-ball LFBGA (NB)



Ordering Information

Ordering Code	Package Code	Package Type
PI74SSTU32864NB	NB	96-Ball LFBGA
PI74SSTU32864NBE	NB	Pb-free & Green, 96-Ball LFBGA

Notes:

1. Thermal characteristics can be found on the company web site at www.pericom.com/packaging/
2. Number of Transistors = TBD