

# IS31AP4913 3D AND BASS ENHANCE STEREO HEADPHONE DRIVER EVALUATION BOARD GUIDE

## DESCRIPTION

The IS31AP4913 evaluation board is a fully assembled and tested PCB. The IS31AP4913 is a high quality stereo headphone driver with 3D and bass enhance designed to allow the removal of the output DC-blocking capacitors for reduced component count and cost. The features 3D and bass can be externally adjusted via a simple RC network.

## FEATURES

- Supply voltage range from 2.7V to 5.5V
- Low output noise (8 $\mu$ V)
- High SNR (102dB)
- -92dB PSRR
- No output DC-blocking capacitors
- Pulse Count Control serial interface
- Available in QFN-20(3mm  $\times$  3mm) package

## QUICK START

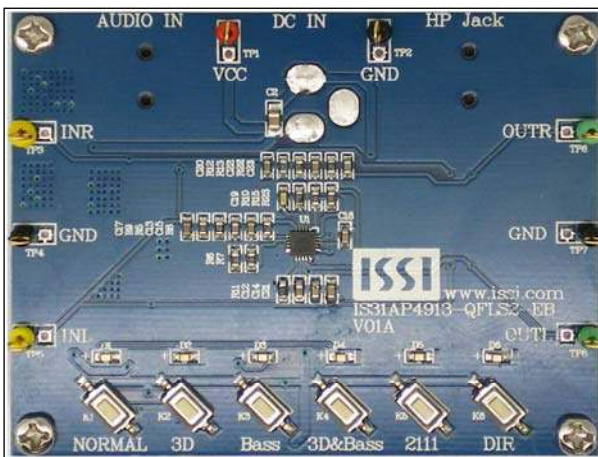

Figure 1: Photo of IS31AP4913 Evaluation Board

## RECOMMENDED EQUIPMENT

- 5.0V, 2A power supply
- Audio source (i.e. MP3 player, Notebook PC, etc.)
- Headphone (32 $\Omega$ )

## ABSOLUTE MAXIMUM RATINGS

- $\leq$  5.5V power supply

**Caution: Do not exceed the conditions listed above; otherwise the board will be damaged.**

## PROCEDURE

Follow the steps listed below to verify IS31AP4913 evaluation board operation.

**Caution: Do not turn on the power supply until all connections are completed.**

- 1) Connect headphone (32 $\Omega$ ) to the connector (HP Jack).
- 2) Connect the ground terminal of the power supply to the GND and the positive terminal to the VCC. Or connect DC power to connector (DC IN).
- 3) Connect the audio sources to the INR terminal (right channel) and INL terminal (left channel); or connect audio sources to the connector (AUDIO IN).
- 4) Turn on the power supply, and pay attention to the supply current. If the current exceeds 200mA, please check for circuit fault.
- 5) Turn on the audio sources.

## ORDERING INFORMATION

Part No.	Temperature Range	Package
IS31AP4913-QFLS2-EB	-40°C to +85°C (Industrial)	QFN-20, Lead-free

Table 1: Ordering Information

For pricing, delivery, and ordering information, please contacts Lumissil's analog marketing team at [analog@Lumissil.com](mailto:analog@Lumissil.com) or (408) 969-6600.

# IS31AP4913 3D AND BASS ENHANCE STEREO HEADPHONE DRIVER EVALUATION BOARD GUIDE

## PERFORMANCE DESCRIPTION

The IS31AP4913 evaluation board has six buttons to switch between the different modes. The operating mode is indicated by an LED illuminated above the appropriate buttons. The (1~4) modes are performed by IS31AP4913.

- 1) (Default mode) normal: basic operating mode
- 2) 3D mode: enable 3D enhance function.
- 3) Bass mode: enable bass enhance function.
- 4) 3D&Bass: enable 3D and bass enhance function.
- 5) 2111: use the output DC-blocking capacitors headphone amplifier (HWD2111) drive headphone
- 6) DIR: use the input audio source direct drive headphone.

**Note:** The IS31AP4913 headphone driver provides solely audio function capability on the evaluation board.

## SOFTWARE SUPPORT

Please refer to the integrated program.

**Note:** Please refer to the datasheet to get more information about IS31AP4913.

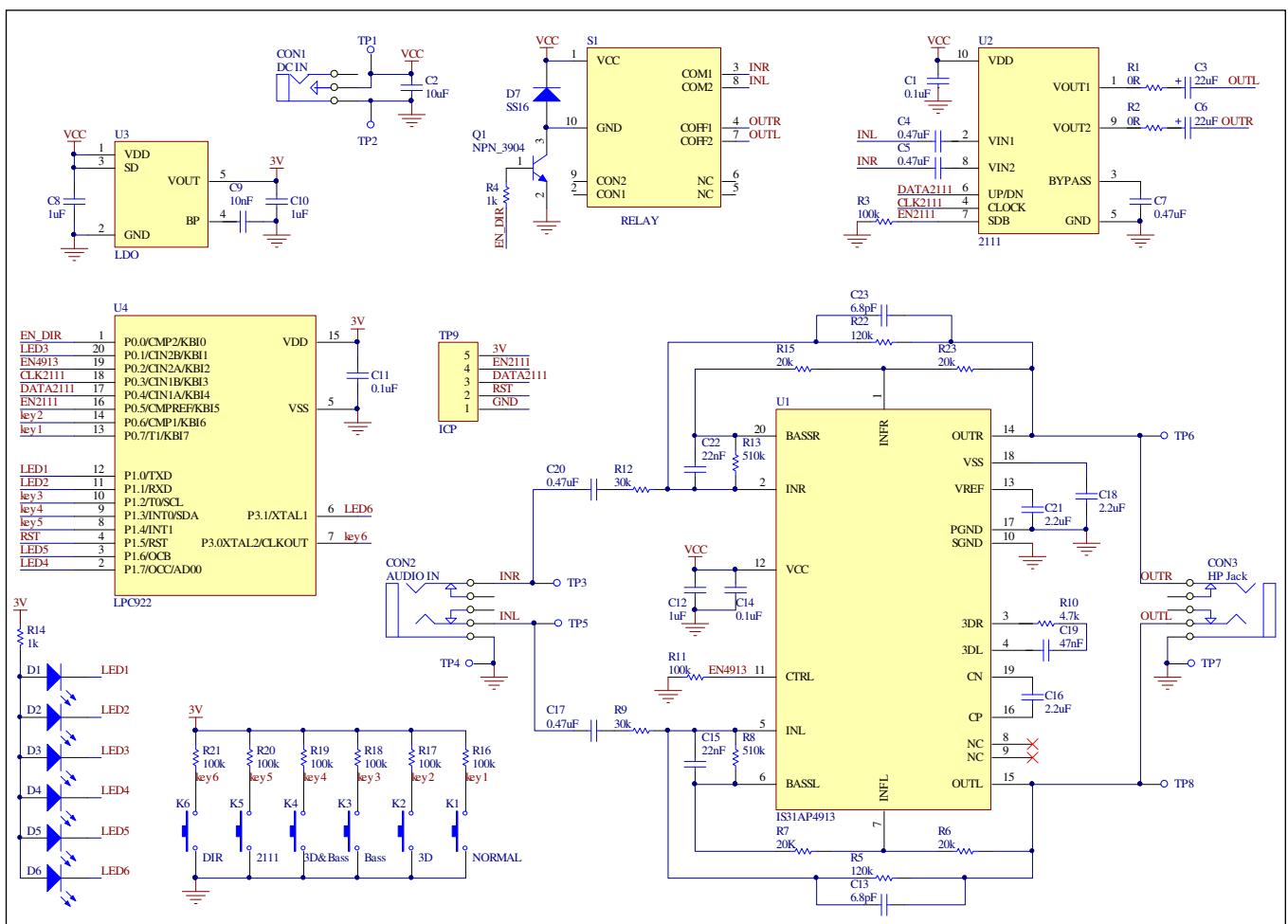

Figure 2: IS31AP4913 Application Schematic

# IS31AP4913 3D AND BASS ENHANCE STEREO HEADPHONE DRIVER EVALUATION BOARD GUIDE



## BILL OF MATERIALS

Name	Symbol	Description	Qty	Supplier	Part No.
Audio Amplifier	U1	3D,Bass Stereo Headphone Driver	1	Lumissil	IS31AP4913
Audio Amplifier	U2	Headphone Amplifier	1	HWD	HWD2111
LDO	U3	LDO	1	PAM	PAM3101
MCU	U4	Microcontroller	1	NXP	LPC922
Relay	S1	Relay, 5V	1	Panasonic	TQ2-5V
Transistor	Q1	Transistor, NPN,3904	1	Avic	MMBT3904LT1
Diode	D1~D6	Diode, LED Blue, SMD	6	Everlight	19-217/BHC-ZL1M2RY/3T
Resistor	R1,R2	RES,0Ω,1/16W,±5%,SMD	2	Yageo	RL0603JR-0700RL
Resistor	R3,R11	RES,100k,1/16W,±5%,SMD	2	Yageo	RC0603JR-07100KL
Resistor	R4,R14	RES,1k,1/16W,±5%,SMD	2	Yageo	RC0603JR-071KL
Resistor	R5,R22	RES,120k,1/16W,±1%,SMD	2	Yageo	RC0603FR-07120KL
Resistor	R6,R7,R15,R23	RES,20k,1/16W,±1%,SMD	4	Yageo	RC0603FR-0720KL
Resistor	R8,R13	RES,510k,1/16W,±5%,SMD	2	Yageo	RC0603JR-0720KL
Resistor	R9,R12	RES,30k,1/16W,±1%,SMD	2	Yageo	RC0603FR-0730KL
Resistor	R10	RES,4.7k,1/16W,±5%,SMD	1	Yageo	RC0603JR-074K7L
Resistor	R16~R21	RES,10k,1/16W,±5%,SMD	6	Yageo	RC0603JR-0710KL
Capacitor	C1,C11,C14	CAP,0.1μF,50V,±10%,SMD	3	Yageo	CC0603KKX7R9BB106
Capacitor	C2	CAP,10μF,16V,±20%,SMD	1	Yageo	CC0805KKX7R6BB106
Capacitor	C3,C6	CAP,22μF,25V,±20%,SMD	2	Yageo	
Capacitor	C4,C5,C7	CAP,0.47μF,50V,±10%,SMD	3	Yageo	CC0603KKX7R9BB474
Capacitor	C8,C10,C12	CAP,1μF,50V,±10%,SMD	3	Yageo	CC0603KKX7R9BB105
Capacitor	C9	CAP,10nF,50V,±10%,SMD	1	Yageo	CC0603KKX7R9BB103
Capacitor	C13,C23	CAP,6.8pF,50V,±10%,SMD	2	Yageo	CC0603KKX7R9BB6P8
Capacitor	C15,C22	CAP,22nF,50V,±10%,SMD	2	Yageo	CC0603KKX7R9BB103
Capacitor	C16,C18,C21	CAP,2.2μF,16V,±10%,SMD	3	Yageo	CC0603KKX7R7BB225
Capacitor	C17,C20	CAP,0.47μF,50V,±10%,SMD	2	Yageo	CC0603KKX7R9BB474
Capacitor	C19	CAP,47nF,50V,±10%,SMD	1	Yageo	CC0603KKX7R9BB473
Connector	DC IN	2.5mm DC connector	1		
Connector	AUDIO IN	3.5mm mini connector	1		
Connector	HP Jack	3.5mm mini connector	1		

Bill of Materials, refer to Figure 2 above.

# IS31AP4913 3D AND BASS ENHANCE STEREO HEADPHONE DRIVER EVALUATION BOARD GUIDE

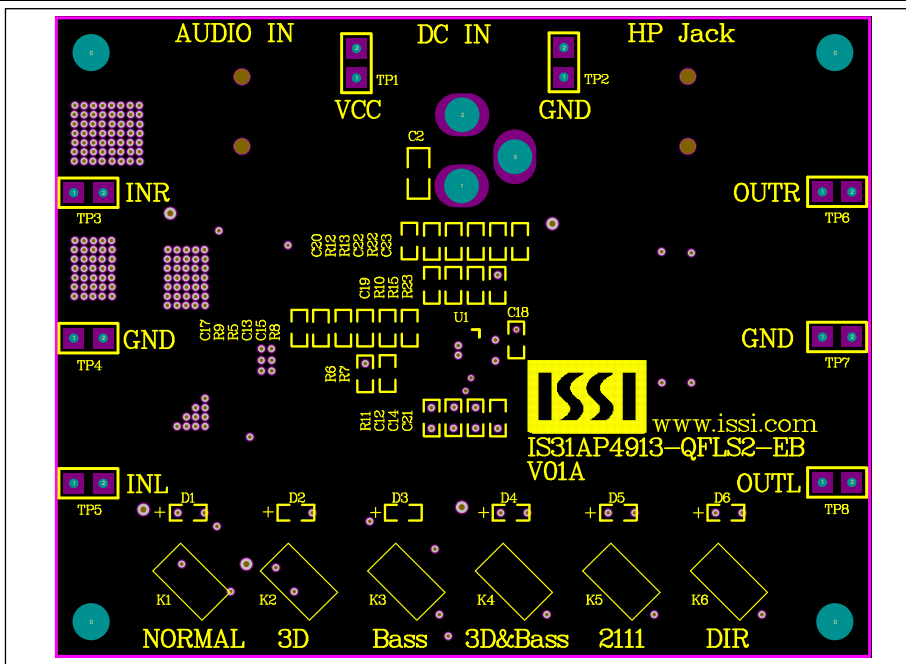

Figure 3: Board Component Placement Guide - Top Layer

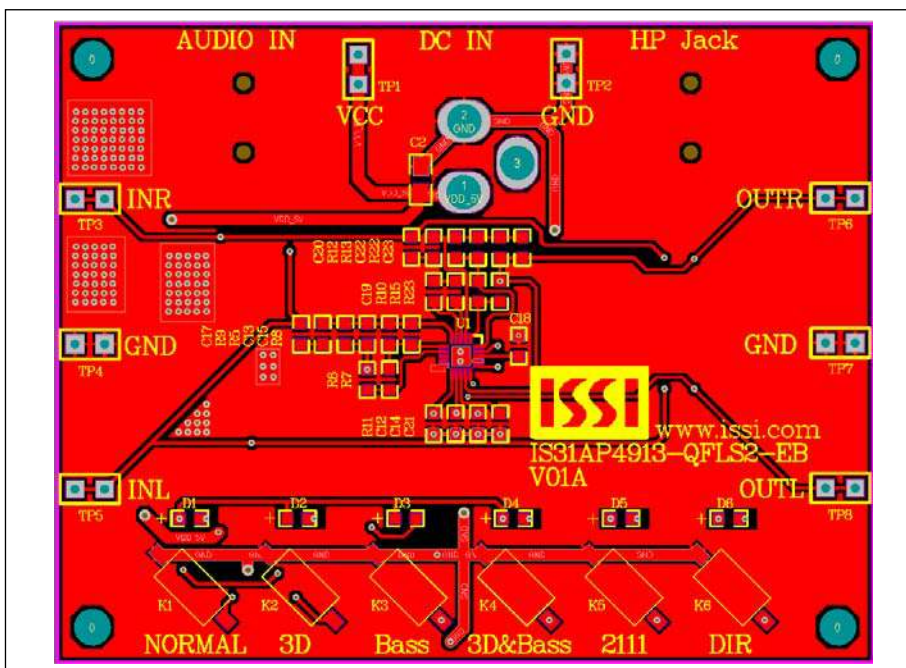

Figure 4: Board PCB Layout - Top Layer

# IS31AP4913 3D AND BASS ENHANCE STEREO HEADPHONE DRIVER EVALUATION BOARD GUIDE

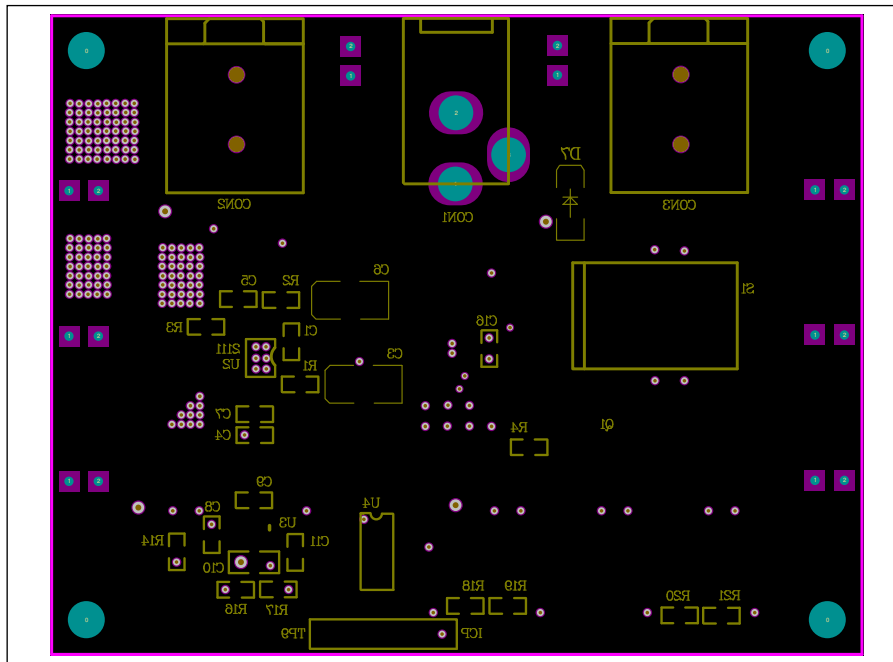

Figure 5: Board Component Placement Guide - Bottom Layer

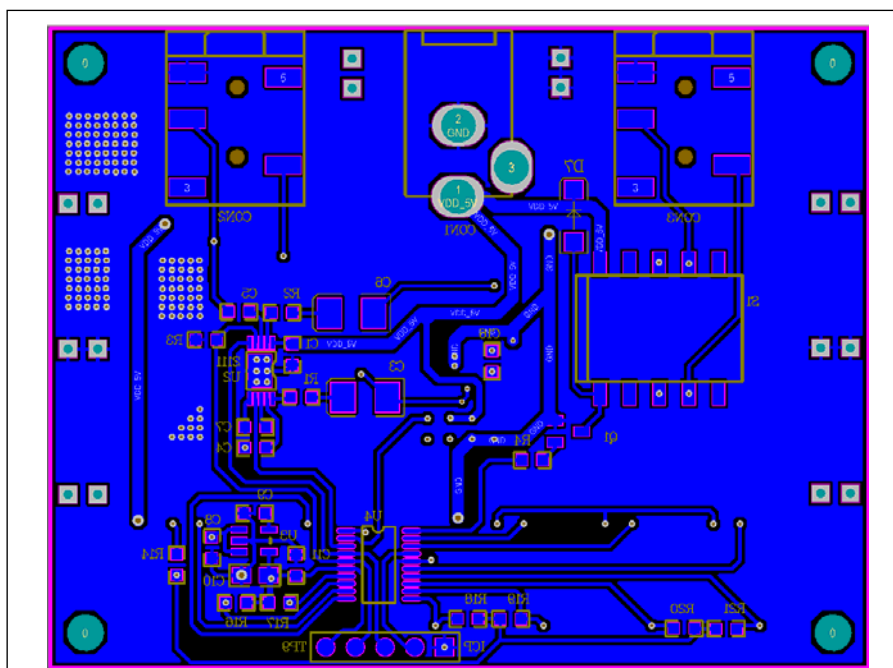

Figure 6: Board PCB Layout - Bottom Layer

Copyright © 2014 Lumissil Microsystems. All rights reserved. Lumissil Microsystems reserves the right to make changes to this specification and its products at any time without notice. Lumissil Microsystems assumes no liability arising out of the application or use of any information, products or services described herein. Customers are advised to obtain the latest version of this device specification before relying on any published information and before placing orders for products.

Lumissil Microsystems does not recommend the use of any of its products in life support applications where the failure or malfunction of the product can reasonably be expected to cause failure of the life support system or to significantly affect its safety or effectiveness. Products are not authorized for use in such applications unless Lumissil Microsystems receives written assurance to its satisfaction, that:

- the risk of injury or damage has been minimized;
- the user assume all such risks; and
- potential liability of Lumissil Microsystems is adequately protected under the circumstances