

THIS DRAWING IS UNPUBLISHED. RELEASED FOR PUBLICATION
 © COPYRIGHT BY TYCO ELECTRONICS CORPORATION. ALL RIGHTS RESERVED.

LOC	DIST	REVISIONS			
P	LTR	DESCRIPTION	DATE	DWN	APVD
AG	53	0	RELEASED	25JAN06	JDP JGH

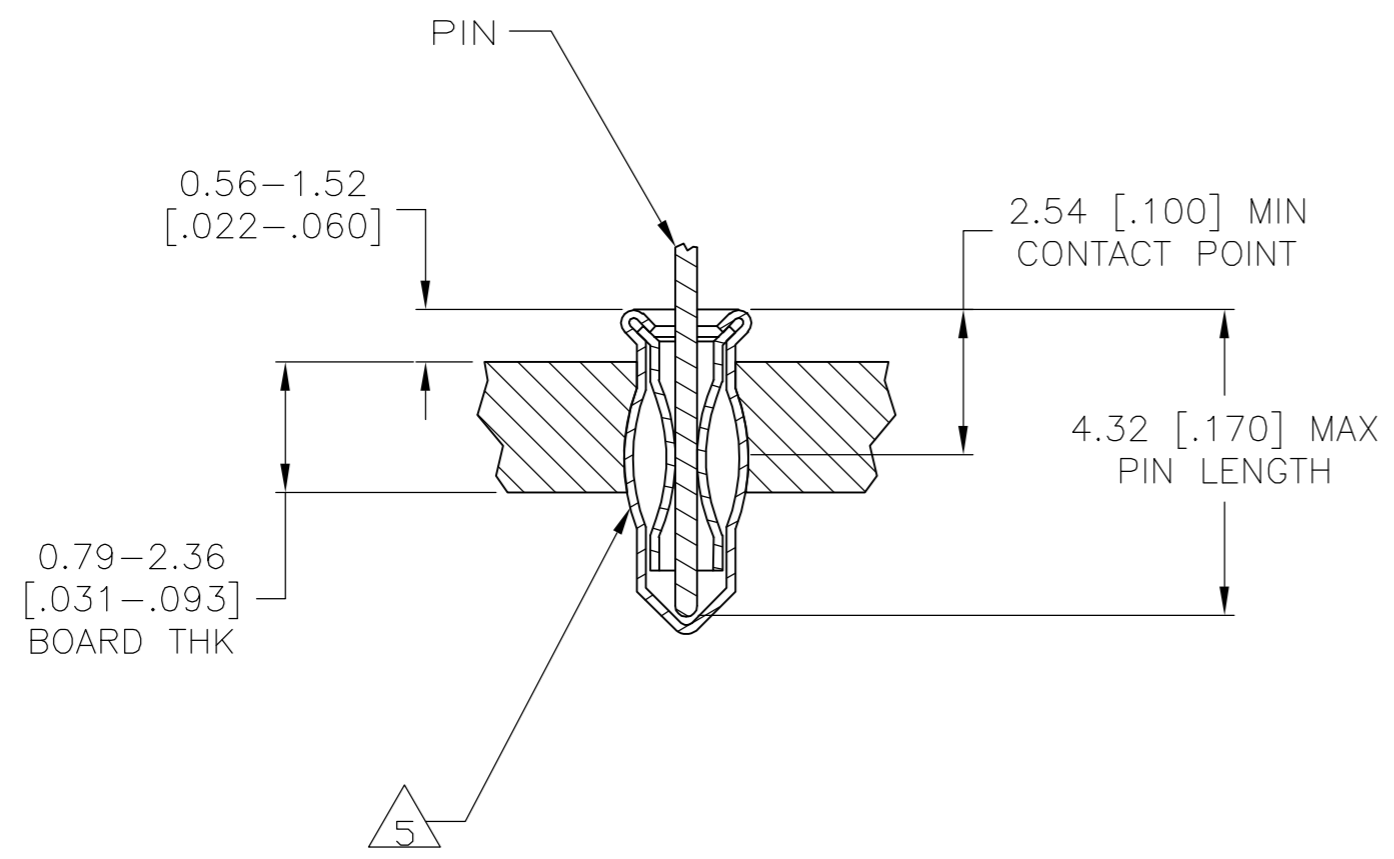
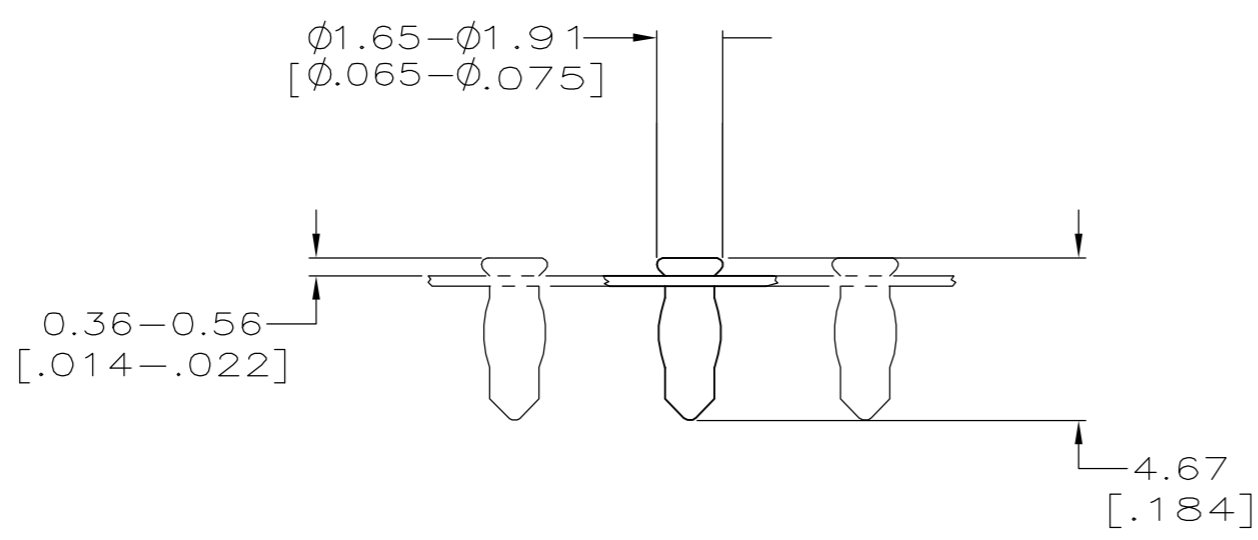
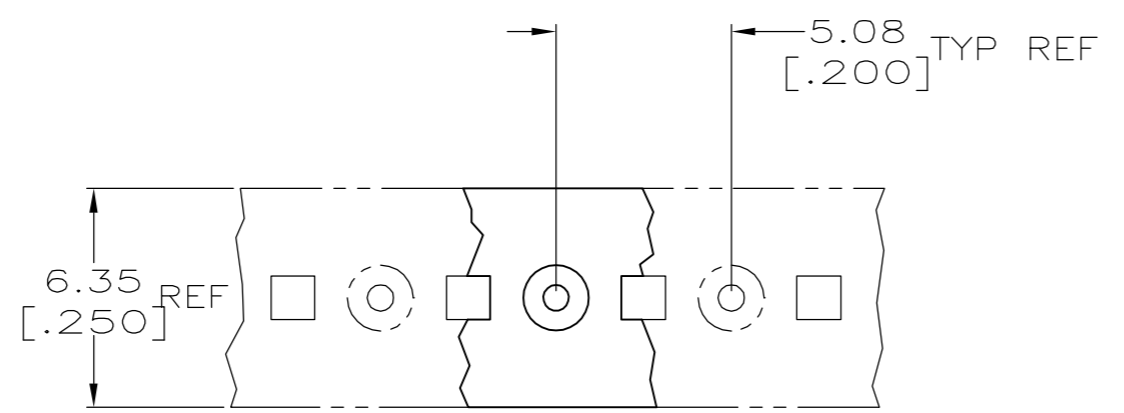

- 1 MATERIAL:
EYELET - COPPER PER ASTM B 152
SPRING - BERYLLIUM COPPER PER ASTM B 194
- 2 TIN PLATE PER ASTM B 545, 0.00254 [.000100] MIN THK.
- 3 PACKAGED, 50,000 PER REEL
- 4 TO INSURE 1/2 OZ MIN RETENTION DO NOT EXCEED 0.10 [.004] DIFFERENCE IN PIN DIA WHEN CHANGING TO A SMALLER DIA PIN
- 5 PRODUCT IS OVALIZED FOR RETENTION IN THE P.C. BOARD. THE RECOMMENDED HOLE DIAMETER IS 1.32 [.052] MINIMUM, +0.08 [.003] MAX. PRIOR TO SOLDERING.
- 6 PACKAGED 10,000 PER REEL

2.54-4.32 [.100-.170]	0.36-0.66 [0.014-0.026]	TIN 2	TIN 2	6 1-5645956-1
2.54-4.32 [.100-.170]	0.36-0.66 [0.014-0.026]	TIN 2	TIN 2	3 5645956-1
LENGTH	DIA 4	SPRING	EYELET	PART NO.

THIS DRAWING IS A CONTROLLED DOCUMENT.

DIMENSIONS: mm [INCHES]	TOLERANCES UNLESS OTHERWISE SPECIFIED:	DWN J. POLIGNONE 25JAN06	Tyco Electronics Corporation Harrisburg, PA 17105-3608
	0 PLC ± -	CHK J. HAVENER 25JAN06	
	1 PLC ± -	APVD J. HAVENER 25JAN06	
	2 PLC ± -	PRODUCT SPEC	
	3 PLC ± 0.20[.008]	APPLICATION SPEC	NAME
	4 PLC ± -	114-26004	MINIATURE SPRING SOCKET ASSY
	ANGLES ± -	108-14008	SERIES 2 LONG
	FINISH	114-26004	WITHOUT SEALANT
MATERIAL 1	SEE TABLE	WEIGHT -	SIZE A2
		CUSTOMER DRAWING	CAGE CODE 00779
			DRAWING NO C=5645956
			RESTRICTED TO -
			SCALE 1:1
			SHEET 1 OF 1
			REV 0