

CDBMS140-HF Thru. CDBMS1200-HF

Reverse Voltage: 40 to 200 Volts

Forward Current: 1.0 Amp

RoHS Device

Halogen Free

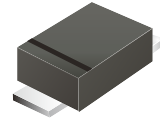

Features

- High current capability.
- Extremely low thermal resistance.
- For surface mount application.
- Low forward voltage.

Mechanical data

- Epoxy: UL 94V0 rated flame retardant.
- Case: SOD-123F, molded plastic.
- Terminals: Lead Free Plating (Tin Finish)
Solderable per MIL-STD-202, method 208.
- Polarity: Indicated by cathode band.
- Weight: 0.022 grams (Approx.)

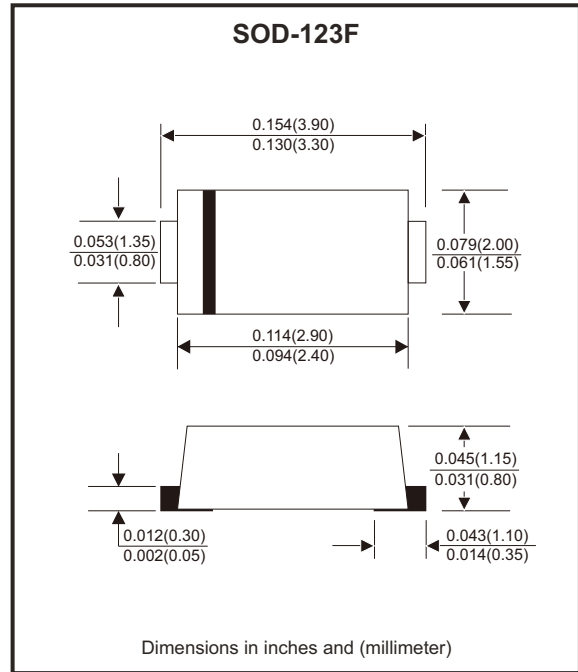

Circuit Diagram



Maximum Ratings (at TA=25°C unless otherwise noted)

Parameter	Symbol	CDBMS					Unit
		140-HF	160-HF	1100-HF	1150-HF	1200-HF	
Max. Repetitive peak reverse voltage	V_{RRM}	40	60	100	150	200	V
Max. RMS voltage	V_{RMS}	28	42	70	105	140	V
Max. DC blocking voltage	V_{DC}	40	60	100	150	200	V
Max. Average forward rectified current	I_F	1.0					A
Max. Instantaneous forward voltage $I_F=1.0A @T_A=25^\circ C$	V_F	0.52	0.66	0.83	0.87	0.90	V
Peak forward surge current, 8.3ms single half sine-wave superimposed on rated load (JEDEC methode)	I_{FSM}	30					A
Max. DC reverse current @ $T_A=25^\circ C$ at Rated DC blocking voltage @ $T_A=100^\circ C$	I_R	0.5 20		0.2 10		mA	
Typical junction capacitance (Note 1)	C_J	60		25			pF
Typical thermal resistance	$R_{\theta C}$	45					°C/W
Operating temperature range	T_J	-50 to +125		-50 to +150			°C
Storage temperature range	T_{STG}	-55 to +150					°C

Note: 1. Measured at 1.0MHZ and applied reverse voltage of 4V DC.

Company reserves the right to improve product design , functions and reliability without notice.

REV:B

Rating and Characteristic Curves (CDBMS140-HF Thru. CDBMS1200-HF)

Fig.1 - Typical Forward Current Derating Curve

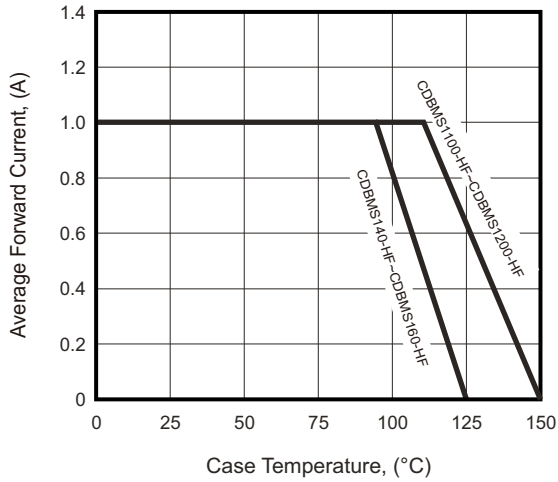

Fig.2 - Typical Forward Characteristics

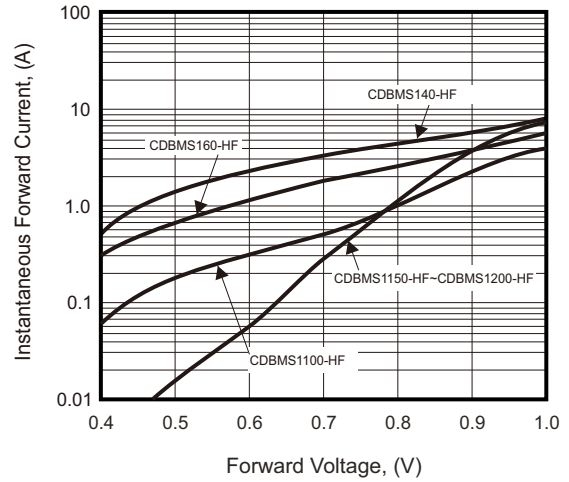

Fig.3 - Maximum Non-repetitive Forward Surge Current

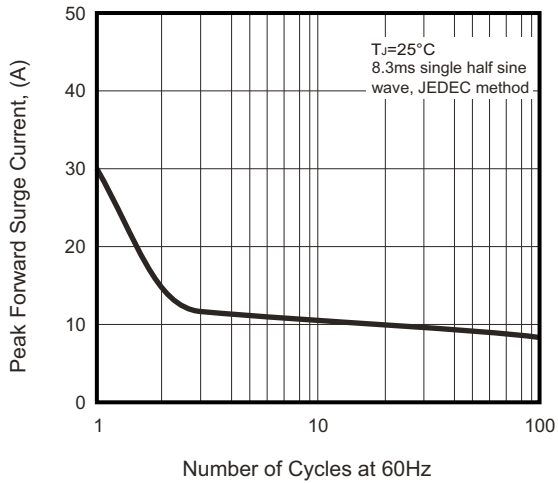

Fig.4 - Typical Reverse Characteristics

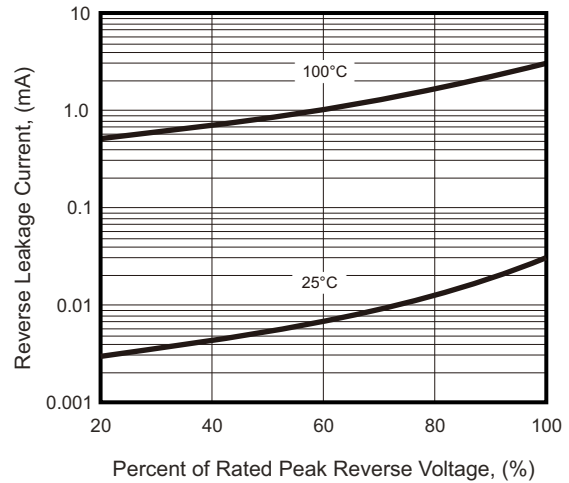
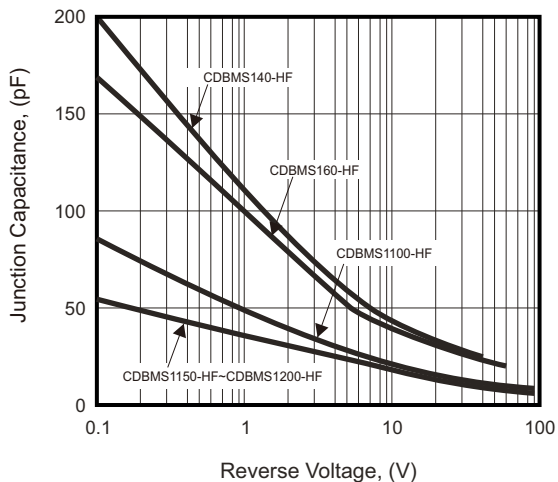
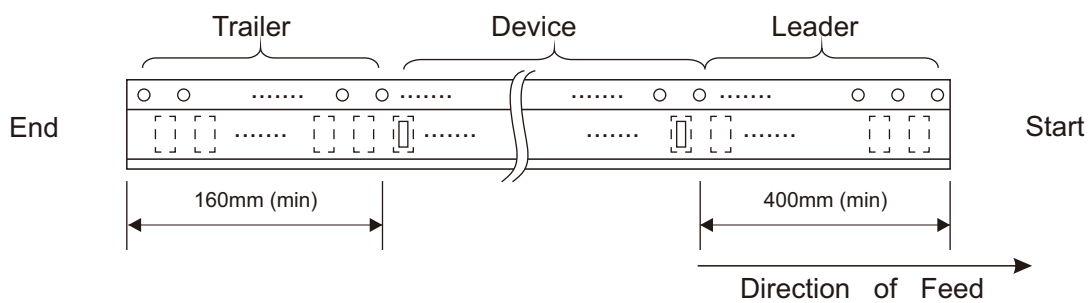
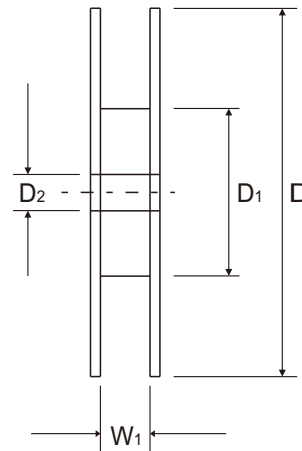
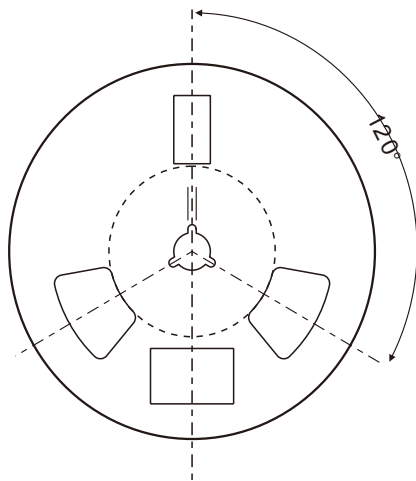
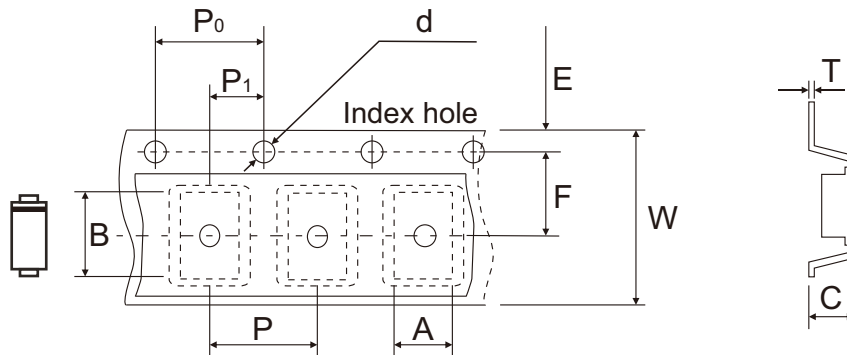

Fig.5 - Typical Junction Capacitance



Company reserves the right to improve product design, functions and reliability without notice.

Reel Taping Specification



SOD-123F	SYMBOL	A	B	C	d	D	D1	D2
	(mm)	2.05 ± 0.10	4.01 ± 0.10	1.32 ± 0.10	2.00 ± 0.10	178 Max.	50 Min.	13.30 ± 1.00
	(inch)	0.081 ± 0.004	0.158 ± 0.004	0.052 ± 0.004	0.079 ± 0.004	7.008 Max.	1.969 Min.	0.524 ± 0.039

SOD-123F	SYMBOL	E	F	P	P0	P1	T	W	W1
	(mm)	1.75 ± 0.10	3.50 ± 0.10	4.00 ± 0.10	4.00 ± 0.10	2.00 ± 0.05	0.24 ± 0.03	8.00 ± 0.30	9.30 ± 1.00
	(inch)	0.069 ± 0.004	0.138 ± 0.004	0.157 ± 0.004	0.157 ± 0.004	0.079 ± 0.002	0.009 ± 0.001	0.315 ± 0.012	0.366 ± 0.039

Company reserves the right to improve product design, functions and reliability without notice.

Marking Code

Part Number	Marking Code
CDBMS140-HF	C4.
CDBMS160-HF	C6.
CDBMS1100-HF	CA.
CDBMS1150-HF	CB.
CDBMS1200-HF	CC.



XX = Product type marking code

“ . ” = Halogen Free

Suggested PAD Layout

SIZE	SOD-123F	
	(mm)	(inch)
A	1.34	0.053
B	1.80	0.071
C	1.52	0.060
D	2.86	0.113
E	4.20	0.165

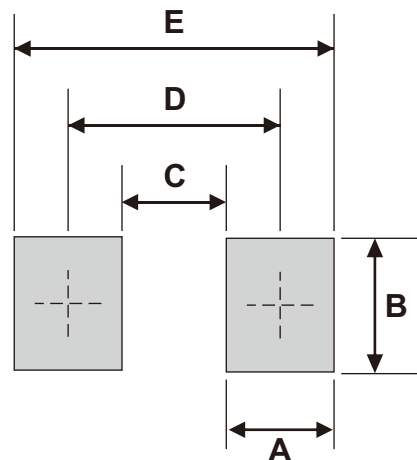

Note: 1. The pad layout is for reference purposes only.

Standard Packaging

Case Type	REEL PACK	
	REEL (pcs)	Reel Size (inch)
SOD-123F	3,000	7

Company reserves the right to improve product design , functions and reliability without notice.