

USB Power Manager with 2A High Voltage Buck Regulator

DESCRIPTION

Demonstration circuit DC1210A is high voltage switching buck regulator, USB Powerpath controller and Li-Ion battery charger. It is based on the LTC4090 and provides the following functions:

2A buck regulator with 6-38V (60V max) input range and with output voltage tracking battery voltage, full featured battery charger with 4.2V float, USB power manager that ensures compliance with the USB power specification and a power path manager for the battery.

PERFORMANCE SUMMARY Specifications are at TA = 25°C

SYMBOL	PARAMETER	CONDITIONS	MIN	TYP	MAX	UNITS
V _{IN}	Input Supply Range - USB		4.35		5.5	V
V _{HVIN}	Input Supply Range - HVIN	(Withstands up to 60V without damage)	6		60	V
V _{OVLO}	HVIN Overvoltage Lockout Threshold		38	41.5	45	V
Battery Charger						
I _{CHG}	Charging current	V _{HVIN} = 12V, V _{BAT} = 3.6V, R ₄ = 71.5kΩ	650	700	750	mA
V _{FLOAT}	V _{BAT} Regulated Output Voltage	I _{BAT} = 2mA	4.165	4.200	4.235	V
I _{TRKL}	Trickle Charge Current	V _{BAT} = 2V	49	70	84	mA
ΔV _{RECHRG}	Recharge threshold	Threshold Voltage Relative to V _{FLOAT}	-65	-100	-135	mV
Input Current						
I _{LIM}	Input current 100mA mode	HPWR = 0V, R ₃ = 2.10kΩ	86	93	105	mA
I _{LIM}	Input Current 500mA mode	HPWR = 5V, R ₃ = 2.10kΩ	452	476	500	mA
I _{IN(SUSP)}	Suspend Mode Input Current	SUSP = 5V		50	100	μA

OPERATING PRINCIPLES

Demo board DC1210A is based on the LTC4090. This chip manages the power supplies that would be typical for a USB powered device. Power is input from either the USB cable or from a high voltage (6V-38V) HVIN input to an intermediate voltage bus.

The intermediate voltage bus is powered from USB or HVIN when available, and from the battery via an ideal diode. The battery charger is a CC/CV timer terminated type capable of charge currents up to 1.5A

The HVIN input has overvoltage protection to 60V. The 2A buck regulator connected to HVIN operates at 800kHz and its output voltage is regulated in the range 3.45V to 4.6V, tracking the battery voltage and typically 0.3V higher to allow most efficient charging.

EQUIPMENT

- 8 DVMs
- 1 DC Supply 0-50V 3A for the HVIN input test
- 1 DC Supply 5V 0.5A for the USB input test
- 1 USB cable with a Mini-B connector at one end and two banana plugs at the other end
- 1 DC Supply 0-5V 3A
- 1 Power Resistor 2ohm 10W
- 1 Adjustable load 0-2A

GETTING STARTED

Refer to Figure 1 for proper measurement equipment setup and follow the procedure below:

1. With power off, connect the input power supplies, meters and output load as shown in Figure 1. For the USB input, use an adjustable 0-5V 0.5A power supply and a cable with a USB Mini-B connector that plugs into J1. For the HVIN input, use a 0-50V 3A adjustable power supply. For simulating the battery, use a 0-5V adjustable power supply that can deliver at least 3A, in parallel with a 2Ω 10W power resistor. Attach a 0-2A adjustable load to the System Output.
2. Check that the jumpers are in their default positions as shown in the schematic.

USB Charging

3. Test of trickle charge current: Set the battery simulator voltage at zero. Set the system load at zero. Disconnect the HVIN power supply from the HVIN input on the demo board or turn it off. Set the USB ON/OFF jumper JP3 in the ON position. Increase the USB input voltage. The charger should activate and green LED D3 will illuminate to indicate charge. Set the USB voltage to 5.0V. The battery will now be in trickle charge mode and the charge current should be in the range 49mA...84mA.
4. Test of normal charge current: Slowly increase the battery voltage to 3.6V and note that when the battery voltage rises above 2.9V the battery charge current will increase to 452mA...500mA.

5. Test of input current limit in 100mA mode: Place the USB Current jumper JP2 in the 100mA position and note that USB current falls to 86mA... 105mA.
6. Test of USB current in Suspend Mode. Set the USB ON/OFF jumper JP3 in the OFF position and check that the USB current drops to less than 90uA.
7. Return the USB ON/OFF jumper JP3 to the ON position and the USB Current jumper JP2 to the 500mA position. The USB current should increase to 452mA...500mA. Increase the system load to 600mA. Note that as the load current becomes higher than the USB current, discharge current is flowing from the battery to the load. The output voltage drops to just below the battery voltage 3.6V.

Adapter Charging

8. Test of operation with HVIN input: Connect the adjustable 0-50V power supply to the demo board HVIN input, turn it on and slowly increase the HVIN voltage. When HVIN exceeds about 6V the USB current drops to zero and current is drawn from HVIN. The red LED D3 will light up to indicate that the buck regulator is active. Set the HVIN input voltage at 12V. Note that the battery is now charging with 650mA...750mA current and the output voltage has increased to about 3.9V. The buck regulator on the HVIN input is now both charging the battery and powering the load. Increase the system load to 1.3A and check that the battery charge current does not drop. (The buck regulator is delivering 1.3A + 0.7A = 2A current).

9. Test of the HVIN input overvoltage protection: Increase the HVIN input voltage slowly and note that as the voltage exceeds 38V...45V the input current will drop to zero indicating that the buck regulator shut down due to overvoltage. The System Load is now powered from the battery (and from USB if

available). Decrease the HVIN voltage and observe that the buckregulator will resume normal operation.

10. Increase the battery voltage and note that the charge current falls to zero when the voltage exceeds 4.167V...4.215V.

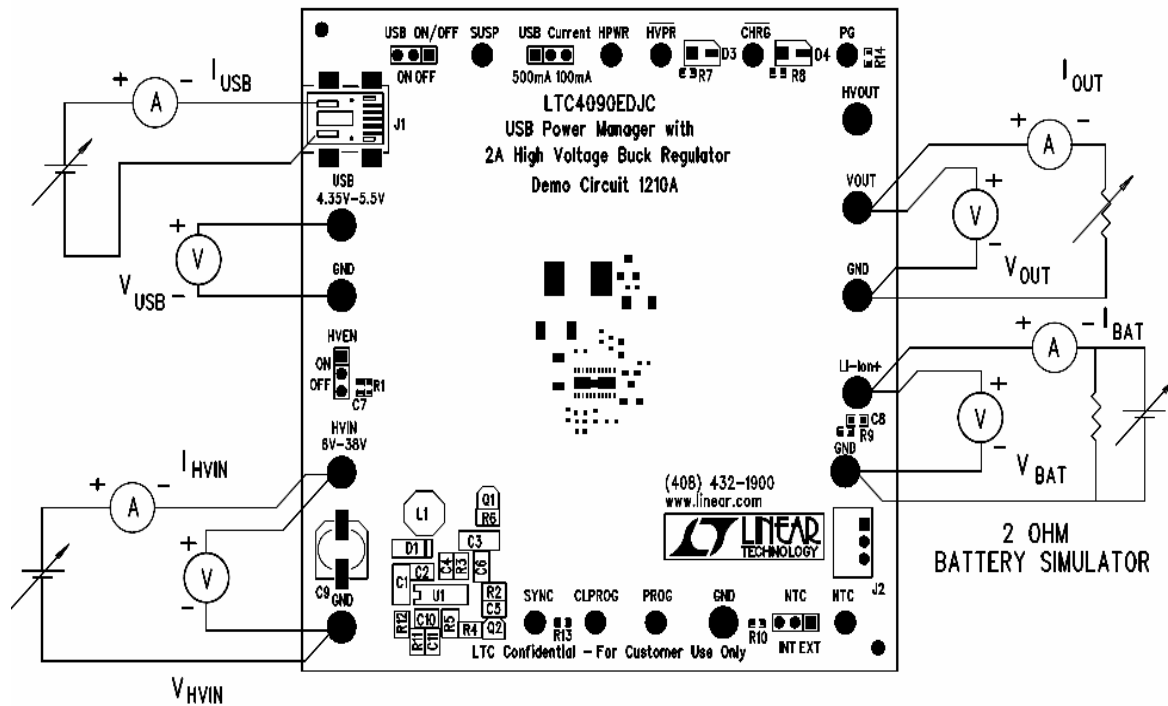
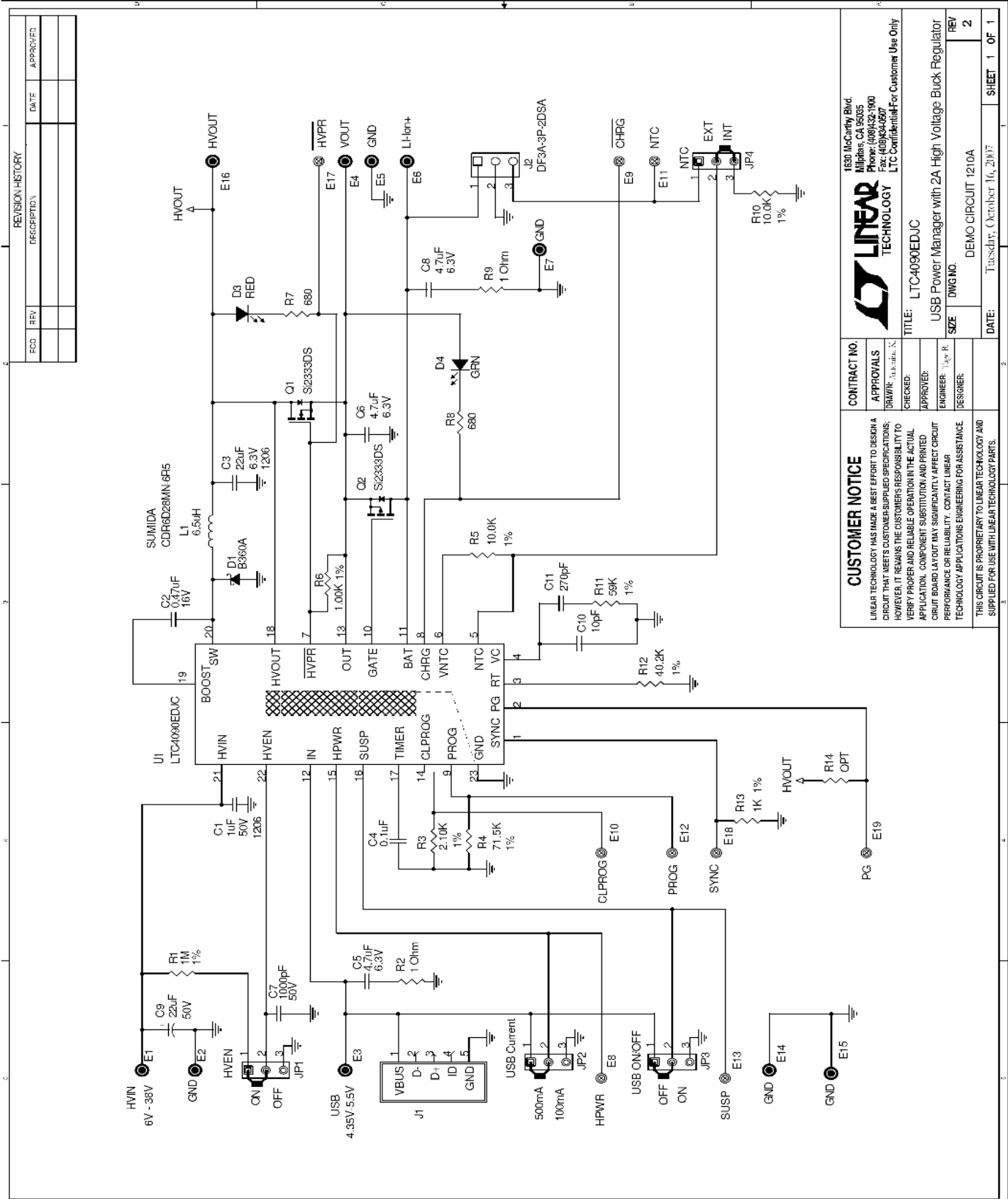

Figure 1. Proper Measurement Equipment Setup



REVISION HISTORY		
REV	DESCRIPTION	DATE

CUSTOMER NOTICE
 LINEAR TECHNOLOGY HAS MADE A BEST EFFORT TO DESIGN A CIRCUIT THAT MEETS CUSTOMER-SUPPLIED SPECIFICATIONS; HOWEVER, IT REMAINS THE CUSTOMER'S RESPONSIBILITY TO VERIFY PROPER AND RELIABLE OPERATION IN THE ACTUAL APPLICATION. COMPONENT SUBSTITUTION AND PRINTED CIRCUIT BOARD LAYOUT MAY SIGNIFICANTLY AFFECT CIRCUIT PERFORMANCE OR RELIABILITY. CONTACT LINEAR TECHNOLOGY APPLICATIONS ENGINEERING FOR ASSISTANCE.

CONTRACT NO. APPROVALS
 DRAWN: [Name], DATE: [Date]

CHECKED: [Name], DATE: [Date]
APPROVED: [Name], DATE: [Date]
ENGINEER: [Name]
DESIGNER: [Name]

TITLE: LTC4090EDJUC
USB Power Manager with 2A High Voltage Buck Regulator

SIZE: []
DWG NO. []

DATE: Tuesday, October 16, 2007
SHEET: 1 OF 1