

CLIFF

CAT.6 RJ45 FEEDTHROUGH CONNECTOR

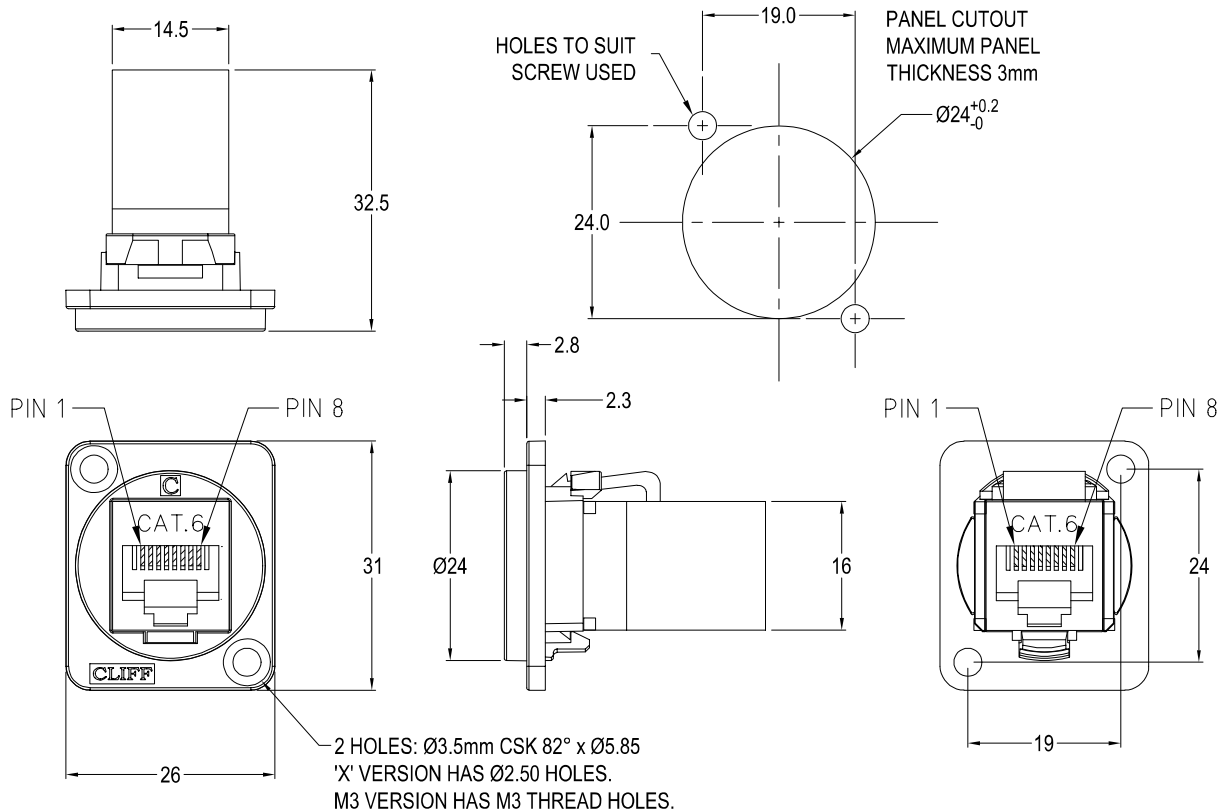

Feedthrough Features

- Fits standard XLR Ø24mm cutout.
- No soldering or punch termination. Use standard cable for each connector style.
- Front or rear mounted.
- Low rear profile

General:

Please note: Functionality is affected by cable quality, length and cable wiring configuration.

Other models available:

Part No.

CP30222	Cat.6 RJ45 Black plastic frame, CSK holes
CP30222W	Cat.6 RJ45 White plastic frame, CSK holes
CP30222M	Cat.6 RJ45 Nickel plated metal frame, CSK holes
CP30222M3	Cat.6 RJ45 Nickel plated metal frame, M3 holes
CP30222MB	Cat.6 RJ45 Black metal frame, CSK holes
CP30222M3B	Cat.6 RJ45 Black metal frame, M3 holes
CP30222X	Cat.6 RJ45 Black plastic frame, PLAIN holes
CP30222XW	Cat.6 RJ45 White plastic frame, PLAIN holes

Material:

1. RJ45 In-Line Coupler: ABS UL94-V0
2. RJ45 In-Line Coupler Contact:
Phosphor Bronze, 3-50 micro inches
gold plating over nickel plate.
3. PCB: FR4
4. Plastic Frame: Polyamide UL94 V-2
5. Metal Frame: Diecast, Black or Nickel plated

Performance:

1. T568A & T568B wiring.
2. Meet ISO/IEC 11801 and EN50173
3. Meet ANSI/TIA/EIA 568B.2
4. Rating: 125VAC RMS 1.5A
5. Operating Temperatures: Min -10°C Max +60°C