MSM5412222B

262,214-Word × 12-Bit Field Memory

GENERAL DESCRIPTION

The LAPIS Semiconductor MSM5412222B is a high performance 3-Mbit, 256K × 12-bit, Field Memory. It is especially designed for high-speed serial access applications such as HDTVs, conventional NTSC TVs, VTRs, digital movies and Multi-media systems. MSM5412222B is a FRAM for wide or low end use in general commodity TVs and VTRs exclusively. MSM5412222B is not designed for the other use or high end use in medical systems, professional graphics systems which require long term picture storage, data storage systems and others. More than two MSM5412222Bs can be cascaded directly without any delay devices among the MSM5412222Bs. (Cascading of MSM5412222B provides larger storage depth or a longer delay).

Each of the 12-bit planes has separate serial write and read ports. These employ independent control clocks to support asynchronous read and write operations. Different clock rates are also supported that allow alternate data rates between write and read data streams.

The MSM5412222B provides high speed FIFO, First-In First-Out, operation without external refreshing: MSM5412222B refreshes its DRAM storage cells automatically, so that it appears fully static to the users. Moreover, fully static type memory cells and decoders for serial access enable the refresh free serial access operation, so that serial read and/or write control clock can be halted high or low for any duration as long as the power is on. Internal conflicts of memory access and refreshing operations are prevented by special arbitration logic.

The MSM5412222B's function is simple, and similar to a digital delay device whose delay-bit-length is easily set by reset timing. The delay length, number of read delay clocks between write and read, is determined by externally controlled write and read reset timings.

Additional SRAM serial registers, or line buffers for the initial access of 256 × 12-bit enable high speed first-bit-access with no clock delay just after the write or read reset timings.

Additionally, the MSM5412222B has write mask function or input enable function (IE), and read-data skipping function or output enable function (OE). The differences between write enable (WE) and input enable (IE), and between read enable (RE) and output enable (OE) are that WE and RE can stop serial write/read address increments, but IE and OE cannot stop the increment, when write/read clocking is continuously applied to MSM5412222B. The input enable (IE) function allows the user to write into selected locations of the memory only, leaving the rest of the memory contents unchanged. This facilitates data processing to display a "picture in picture" on a TV screen.

The MSM5412222B is similar in operation and functionality to LAPIS Semiconductor 1-Mbit Field Memory MSM514222C and 2-Mbit Field Memory MSM518222A. Three MSM514222Cs or one MSM514222C plus one MSM518222A can be replaced simply by one MSM5412222B.

FEATURES

- Single power supply: 5.0 V \pm 0.5 V
- 262,214 words \times 12 bits
- Fast FIFO (First-In First-Out) operation
- High speed asynchronous serial access
 - Read/write cycle time 20 ns/25 ns
 - Access time 18 ns/23 ns
- Direct cascading capability
- Write mask function (Input enable control)
- Data skipping function (Output enable control)
- Self refresh (No refresh control is required)
- Package options:
 - 44-pin 400 mil plastic TSOP (Type 2) (TSOP(2)44-P-400-0.80-K) (Product:MSM5412222B-xxT3-K)
xx indicates speed rank.

PRODUCT FAMILY

Family	Access Time (Max.)	Cycle Time (Min.)	Package
MSM5412222B-25	23 ns	25 ns	400 mil 44-pin TSOP (2)
MSM5412222B-30	25 ns	30 ns	

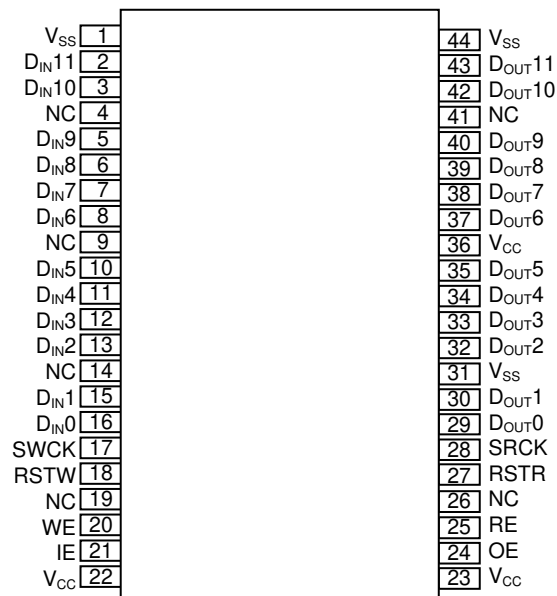
PIN CONFIGURATION (TOP VIEW)

**44-Pin Plastic TSOP (2)
(K Type)**

Pin Name	Function
SWCK	Serial Write Clock
SRCK	Serial Read Clock
WE	Write Enable
RE	Read Enable
IE	Input Enable
OE	Output Enable
RSTW	Write Reset Clock
RSTR	Read Reset Clock
D _{IN} 0 to 11	Data Input
D _{OUT} 0 to 11	Data Output
V _{CC}	Power Supply (5.0 V)
V _{SS}	Ground (0 V)
NC	No Connection

Note: The same power supply voltage must be provided to every V_{CC} pin, and the same GND voltage level must be provided to every V_{SS} pin.

OPERATION

Write Operation

The write operation is controlled by three clocks, SWCK, RSTW, and WE. Write operation is accomplished by cycling SWCK, and holding WE high after the write address pointer reset operation or RSTW.

Each write operation, which begins after RSTW, must contain at least 150 active write cycles, i.e. SWCK cycles while WE is high. To transfer the last data to the DRAM array, which at that time is stored in the serial data registers attached to the DRAM array, an RSTW operation is required after the last SWCK cycle.

Note that every write timing of MSM5412222B is delayed by one clock compared with read timings for easy cascading without any interface delay devices.

Write Reset: RSTW

The first positive transition of SWCK after RSTW becomes high resets the write address counters to zero. RSTW setup and hold times are referenced to the rising edge of SWCK. Because the write reset function is solely controlled by the SWCK rising edge after the high level of RSTW, the states of WE and IE are ignored in the write reset cycle.

Before RSTW may be brought high again for a further reset operation, it must be low for at least two SWCK cycles.

Data Inputs: D_n0 to 11

Write Clock: SWCK

The SWCK latches the input data on chip when WE is high, and also increments the internal write address pointer. Data-in setup time t_{DS} , and hold time t_{DH} are referenced to the rising edge of SWCK.

Write Enable: WE

WE is used for data write enable/disable control. WE high level enables the input, and WE low level disables the input and holds the internal write address pointer. There are no WE disable time (low) and WE enable time (high) restrictions, because the MSM5412222B is in fully static operation as long as the power is on. Note that WE setup and hold times are referenced to the rising edge of SWCK.

Input Enable: IE

IE is used to enable/disable writing into memory. IE high level enables writing. The internal write address pointer is always incremented by cycling SWCK regardless of the IE level. Note that IE setup and hold times are referenced to the rising edge of SWCK.

Read Operation

The read operation is controlled by three clocks, SRCK, RSTR, and RE. Read operation is accomplished by cycling SRCK, and holding RE high after the read address pointer reset operation or RSTR.

Each read operation, which begins after RSTR, must contain at least 150 active read cycles, i.e. SRCK cycles while RE is high.

Read Reset: RSTR

The first positive transition of SRCK after RSTR becomes high resets the read address counters to zero. RSTR setup and hold times are referenced to the rising edge of SRCK. Because the read reset function is solely controlled by the SRCK rising edge after the high level of RSTR, the states of RE and OE are ignored in the read reset cycle. Before RSTR may be brought high again for a further reset operation, it must be low for at least *two SRCK cycles.

Data Out: D_{Out}0 to 11

Read Clock: SRCK

Data is shifted out of the data registers. It is triggered by the rising edge of SRCK when RE is high during a read operation. The SRCK input increments the internal read address pointer when RE is high.

The three-state output buffer provides direct TTL compatibility (no pullup resistor required). Data out is the same polarity as data in. The output becomes valid after the access time interval t_{AC} that begins with the rising edge of SRCK. *There are no output valid time restriction on MSM5412222B.

Read Enable: RE

The function of RE is to gate of the SRCK clock for incrementing the read pointer. When RE is high before the rising edge of SRCK, the read pointer is incremented. When RE is low, the read pointer is not incremented. RE setup times (t_{RENS} and t_{RDSS}) and RE hold times (t_{RENH} and t_{RDSh}) are referenced to the rising edge of the SRCK clock.

Output Enable: OE

OE is used to enable/disable the outputs. OE high level enables the outputs. The internal read address pointer is always incremented by cycling SRCK regardless of the OE level. Note that OE setup and hold times are referenced to the rising edge of SRCK.

Power-up and Initialization

On power-up, the device is designed to begin proper operation after at least 100 μ s after V_{CC} has stabilized to a value within the range of recommended operating conditions. After this 100 μ s stabilization interval, the following initialization sequence must be performed.

Because the read and write address counters are not valid after power-up, a minimum of 80 dummy write operations (SWCK cycles) and read operations (SRCK cycles) must be performed, followed by an RSTW operation and an RSTR operation, to properly initialize the write and the read address pointer. Dummy write cycles/RSTW and dummy read cycles/RSTR may occur simultaneously.

If these dummy read and write operations start while V_{CC} and/or the substrate voltage has not stabilized, it is necessary to perform an RSTR operation plus a minimum of 80 SRCK cycles plus another RSTR operation, and an RSTW operation plus a minimum of 80 SRCK cycles plus another RSTW operation to properly initialize read and write address pointers.

Old/New Data Access

There must be a minimum delay of 150 SWCK cycles between writing into memory and reading out from memory. If reading from the first field starts with an RSTR operation, before the start of writing the second field (before the next RSTW operation), then the data just written will be read out.

The start of reading out the first field of data may be delayed past the beginning of writing in the second field of data for as many as 20 SWCK cycles. If the RSTR operation for the first field read-out occurs less than 20 SWCK cycles after the RSTW operation for the second field write-in, then the internal buffering of the device assures that the first field will still be read out. The first field of data that is read out while the second field of data is written is called "old data".

In order to read out "new data", i.e., the second field written in, the delay between an RSTW operation and an RSTR operation must be at least 150 SRCK cycles. If the delay between RSTW and RSTR operations is more than 21 but less than 150 cycles, then the data read out will be undetermined. It may be "old data" or "new" data, or a combination of old and new data. Such a timing should be avoided.

Cascade Operation

The MSM5412222B is designed to allow easy cascading of multiple memory devices. This provides higher storage depth, or a longer delay than can be achieved with only one memory device.

ELECTRICAL CHARACTERISTICS**Absolute Maximum Ratings**

Parameter	Symbol	Conditon	Rating	Unit
Input Output Voltage	V_T	at $T_a = 25^\circ\text{C}$, V_{SS}	-1.0 to +7.0	V
Output Current	I_{OS}	$T_a = 25^\circ\text{C}$	50	mA
Power Dissipation	P_D	$T_a = 25^\circ\text{C}$	1	W
Operating Temperature	T_{opr}	—	0 to 70	$^\circ\text{C}$
Storage Temperature	T_{stg}	—	-55 to +150	$^\circ\text{C}$

Recommended Operating Conditions

Parameter	Symbol	Min.	Typ	Max.	Unit
Power Supply Voltage	V_{CC}	4.5	5.0	5.5	V
Input High Voltage	V_{IH}	2.4	V_{CC}	$V_{CC} + 1$	V
Input Low Voltage	V_{IL}	-0.1	0	+0.8	V

DC Characteristics

Parameter	Symbol	Condition	Min.	Max.	Unit
Input Leakage Current	I_{LI}	$0 < V_I < V_{CC} + 1 \text{ V}$, Other Pins Tested at $V = 0 \text{ V}$	-10	+10	μA
Output Leakage Current	I_{LO}	$0 < V_O < V_{CC}$	-10	+10	μA
Output "H" Level Voltage	V_{OH}	$I_{OH} = -1 \text{ mA}$	2.4	—	V
Output "L" Level Voltage	V_{OL}	$I_{OL} = 2 \text{ mA}$	—	0.4	V
Operating Current	I_{CC1}	Minimum Cycle Time, Output Open	—	60	mA
Standby Current	I_{CC2}	Input Pin = V_{IH}/V_{IL}	—	5	mA

Capacitance

(Ta = 25°C, f = 1 MHz)

Parameter	Symbol	Max.	Unit
Input Capacitance (D_{IN} , SWCK, SRCK, RSTW, RSTR, WE, RE, IE, OE)	C_I	6	pF
Output Capacitance (D_{OUT})	C_O	7	pF

AC Characteristics

(V_{CC} = 5.0 V ±0.5 V, T_a = 0 to 70°C)

Parameter	Symbol	MSM5412222B-25		MSM5412222B-30		Unit
		Min.	Max.	Min.	Max.	
Access Time from SRCK	t _{AC}	—	23	—	25	ns
D _{OUT} Hold Time from SRCK	t _{DDCK}	6	—	6	—	ns
D _{OUT} Enable Time from SRCK	t _{DECK}	6	23	6	25	ns
SWCK "H" Pulse Width	t _{WSWH}	9	—	12	—	ns
SWCK "L" Pulse Width	t _{WSWL}	10	—	12	—	ns
Input Data Setup Time	t _{DS}	2	—	2	—	ns
Input Data Hold Time	t _{DH}	4	—	4	—	ns
WE Enable Setup Time	t _{WENS}	0	—	0	—	ns
WE Enable Hold Time	t _{WENH}	3	—	3	—	ns
WE Disable Setup Time	t _{WDSS}	0	—	0	—	ns
WE Disable Hold Time	t _{WDSH}	3	—	3	—	ns
IE Enable Setup Time	t _{IENS}	0	—	0	—	ns
IE Enable Hold Time	t _{IENH}	3	—	3	—	ns
IE Disable Setup Time	t _{IDSS}	0	—	0	—	ns
IE Disable Hold Time	t _{IDSH}	3	—	3	—	ns
WE "H" Pulse Width	t _{WWEH}	5	—	10	—	ns
WE "L" Pulse Width	t _{WWEL}	5	—	10	—	ns
IE "H" Pulse Width	t _{WIEH}	5	—	10	—	ns
IE "L" Pulse Width	t _{WIEL}	5	—	10	—	ns
RSTW Setup Time	t _{RSTWS}	0	—	0	—	ns
RSTW Hold Time	t _{RSTWH}	3	—	3	—	ns
SRCK "H" Pulse Width	t _{WSRH}	9	—	12	—	ns
SRCK "L" Pulse Width	t _{WSRL}	10	—	12	—	ns
RE Enable Setup Time	t _{RENS}	0	—	0	—	ns
RE Enable Hold Time	t _{RENH}	3	—	3	—	ns
RE Disable Setup Time	t _{RDSS}	0	—	0	—	ns
RE Disable Hold Time	t _{RDSH}	3	—	3	—	ns
OE Enable Setup Time	t _{OENS}	0	—	0	—	ns
OE Enable Hold Time	t _{OENH}	3	—	3	—	ns
OE Disable Setup Time	t _{ODSS}	0	—	0	—	ns
OE Disable Hold Time	t _{ODSH}	3	—	3	—	ns
Output Buffer Turn-off Delay Time from OE	t _{OEZ}	17	—	17	—	ns
RE "H" Pulse Width	t _{WREH}	5	—	10	—	ns
RE "L" Pulse Width	t _{WREL}	5	—	10	—	ns
OE "H" Pulse Width	t _{WOEH}	5	—	10	—	ns
OE "L" Pulse Width	t _{WOEL}	5	—	10	—	ns
RSTR Setup Time	t _{RSTRS}	0	—	0	—	ns
RSTR Hold Time	t _{RSTRH}	3	—	3	—	ns
SWCK Cycle Time	t _{SWC}	25	—	30	—	ns
SRCK Cycle Time	t _{SRC}	25	—	30	—	ns
Transition Time (Rise and Fall)	t _T	3	30	3	30	ns

- Notes:
1. Input signal reference levels for the parameter measurement are $V_{IH} = 3.0\text{ V}$ and $V_{IL} = 0\text{ V}$. The transition time t_r is defined to be a transition time that signal transfers between $V_{IH} = 3.0\text{ V}$ and $V_{IL} = 0\text{ V}$.
 2. AC measurements assume $t_r = 3\text{ ns}$.
 3. Read address must have more than a 150 address delay than write address in every cycle when asynchronous read/write is performed.
 4. Read must have more than a 150 address delay than write in order to read the data written in a current series of write cycles which has been started at last write reset cycle: this is called "new data read".
When read has less than a 20 address delay than write, the read data are the data written in a previous series of write cycles which had been written before at last write reset cycle: this is called "old data read".
 5. When the read address delay is between more than 21 and less than 149, read data will be undetermined. However, normal write is achieved in this address condition.
 6. Outputs are measured with a load equivalent to 1 TTL load and 30 pF.
Output reference levels are $V_{OH} = 2.0\text{ V}$ and $V_{OL} = 0.8\text{ V}$.

TIMING WAVEFORM

Write Cycle Timing (Write Reset)

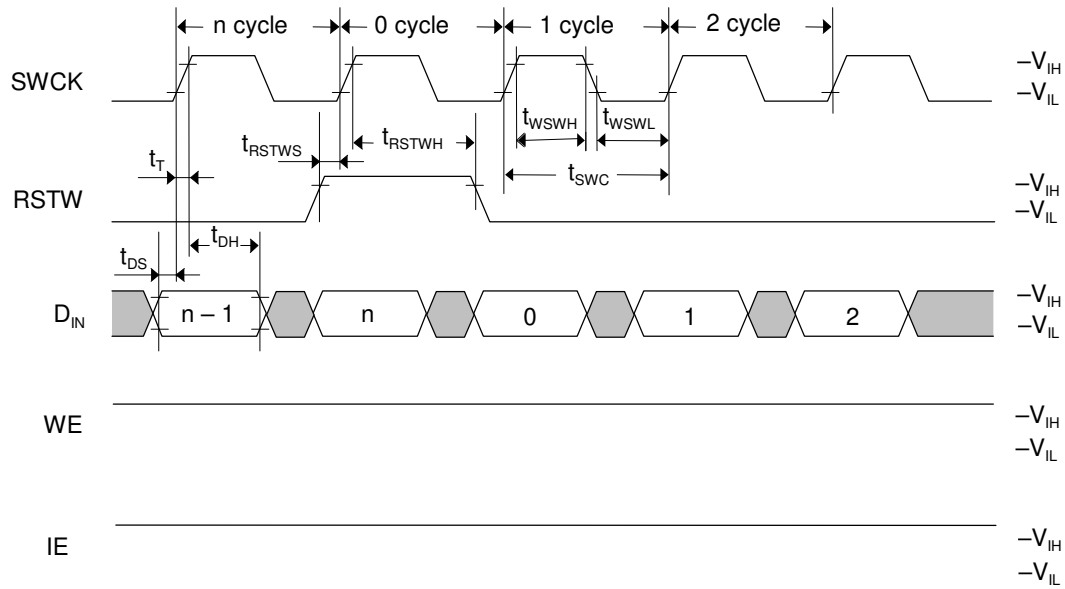

Write Cycle Timing (Write Enable)

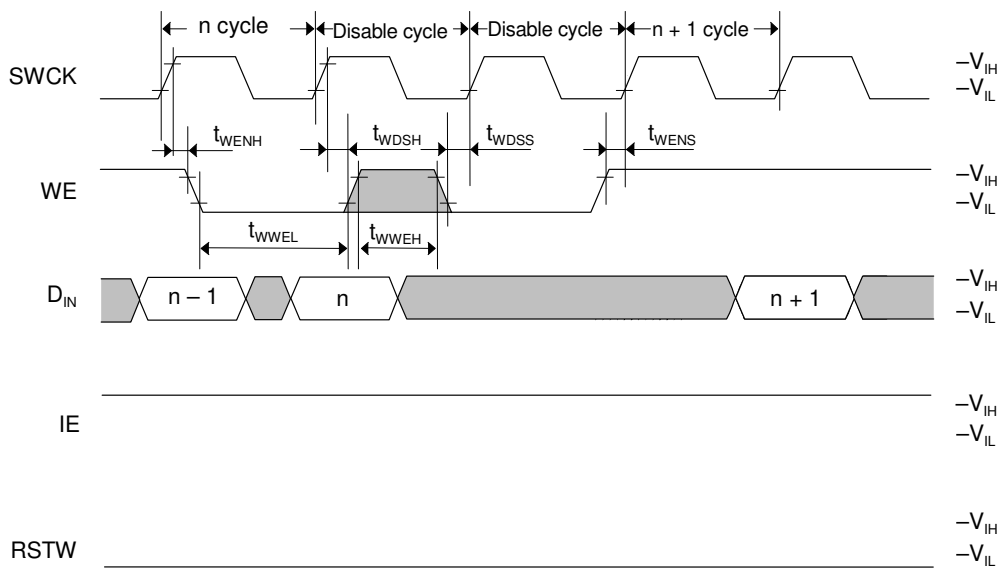

Write Cycle Timing (Input Enable)

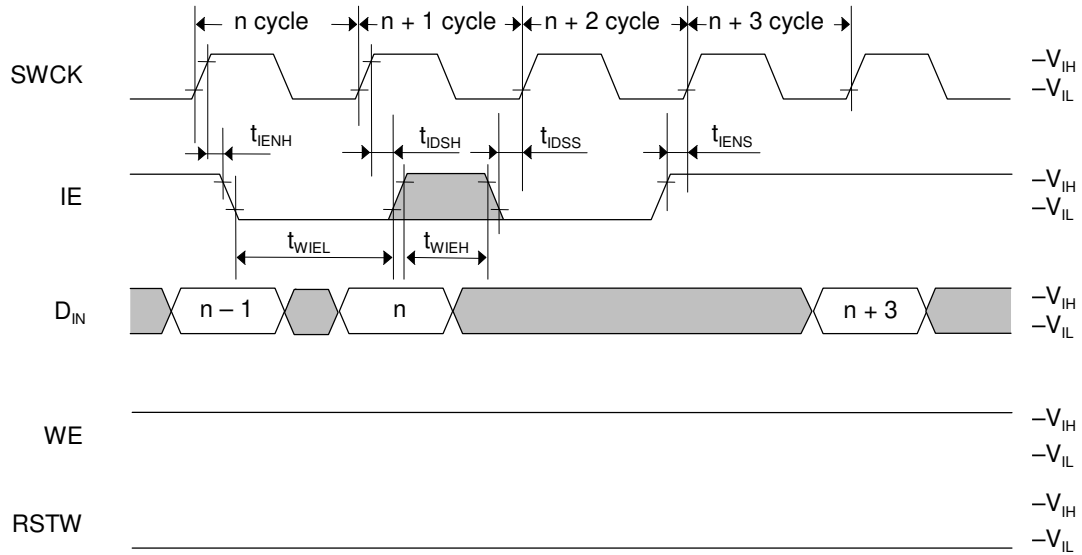

Read Cycle Timing (Read Reset)

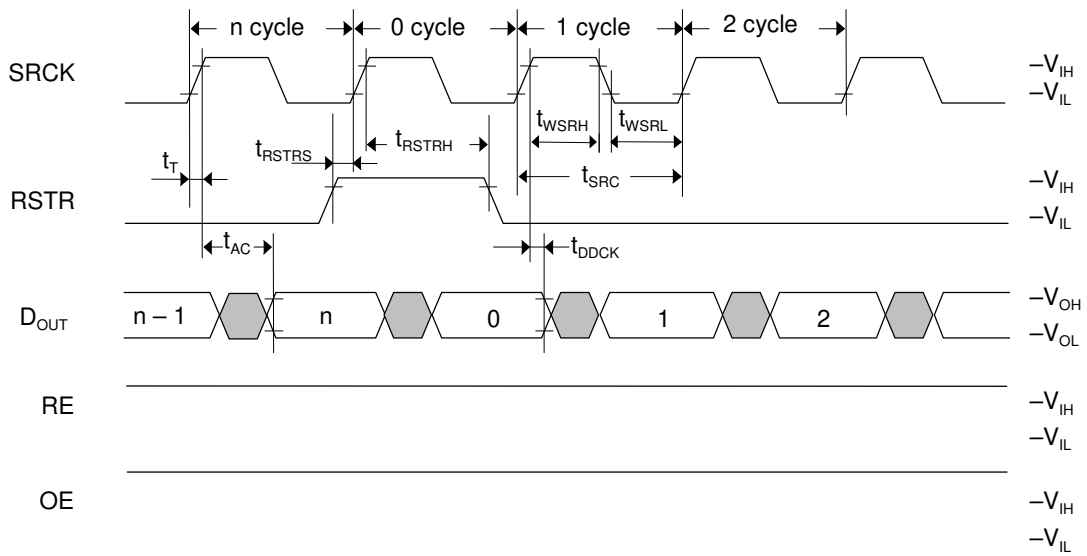

Read Cycle Timing (Read Enable)

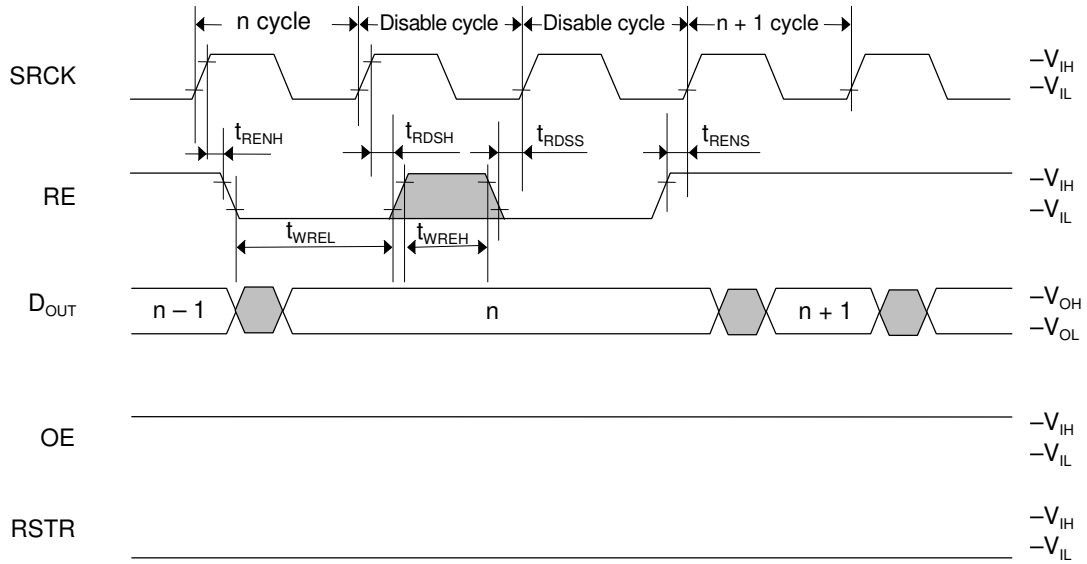

Read Cycle Timing (Output Enable)

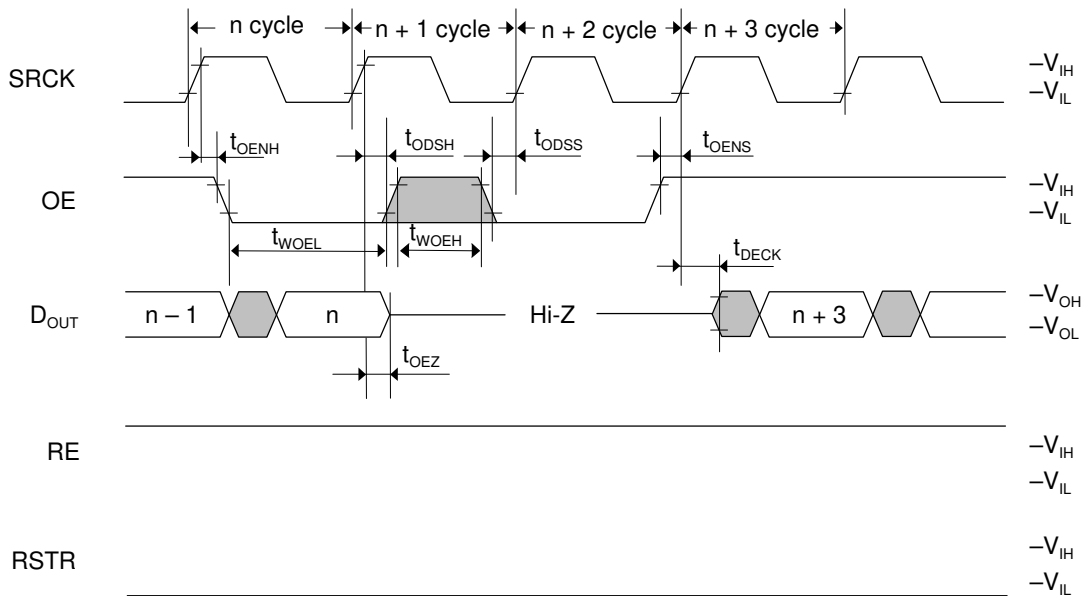

NOTES FOR MOUNTING THE SURFACE MOUNT TYPE PACKAGES

The surface mount type packages are very susceptible to heat in reflow mounting and humidity absorbed in storage.

Therefore, before you perform reflow mounting, contact LAPIS Semiconductor's responsible sales person for the product name, package name, pin number, package code and desired mounting conditions (reflow method, temperature and times).

REVISION HISTORY

Document No.	Date	Page		Description
		Previous Edition	Current Edition	
PEDS5412222B-01	Aug 16, 2002	–	–	First edition
PEDS5412222B-02	Jan. 13, 2012	1 2,3, 14,15	1 2,3, 14	Changed Company name and logo Deleted the 40-pin SOJ package information and PACKAGE DIMENSION
FPEDS5412222B-02	Nov. 01, 2012	–	–	Released formal edition 02

NOTICE

No copying or reproduction of this document, in part or in whole, is permitted without the consent of LAPIS Semiconductor Co., Ltd.

The content specified herein is subject to change for improvement without notice.

The content specified herein is for the purpose of introducing LAPIS Semiconductor's products (hereinafter "Products"). If you wish to use any such Product, please be sure to refer to the specifications, which can be obtained from LAPIS Semiconductor upon request.

Examples of application circuits, circuit constants and any other information contained herein illustrate the standard usage and operations of the Products. The peripheral conditions must be taken into account when designing circuits for mass production.

Great care was taken in ensuring the accuracy of the information specified in this document. However, should you incur any damage arising from any inaccuracy or misprint of such information, LAPIS Semiconductor shall bear no responsibility for such damage.

The technical information specified herein is intended only to show the typical functions of and examples of application circuits for the Products. LAPIS Semiconductor does not grant you, explicitly or implicitly, any license to use or exercise intellectual property or other rights held by LAPIS Semiconductor and other parties. LAPIS Semiconductor shall bear no responsibility whatsoever for any dispute arising from the use of such technical information.

The Products specified in this document are intended to be used with general-use electronic equipment or devices (such as audio visual equipment, office-automation equipment, communication devices, electronic appliances and amusement devices).

The Products specified in this document are not designed to be radiation tolerant.

While LAPIS Semiconductor always makes efforts to enhance the quality and reliability of its Products, a Product may fail or malfunction for a variety of reasons.

Please be sure to implement in your equipment using the Products safety measures to guard against the possibility of physical injury, fire or any other damage caused in the event of the failure of any Product, such as derating, redundancy, fire control and fail-safe designs. LAPIS Semiconductor shall bear no responsibility whatsoever for your use of any Product outside of the prescribed scope or not in accordance with the instruction manual.

The Products are not designed or manufactured to be used with any equipment, device or system which requires an extremely high level of reliability the failure or malfunction of which may result in a direct threat to human life or create a risk of human injury (such as a medical instrument, transportation equipment, aerospace machinery, nuclear-reactor controller, fuel-controller or other safety device). LAPIS Semiconductor shall bear no responsibility in any way for use of any of the Products for the above special purposes. If a Product is intended to be used for any such special purpose, please contact a ROHM sales representative before purchasing.

If you intend to export or ship overseas any Product or technology specified herein that may be controlled under the Foreign Exchange and the Foreign Trade Law, you will be required to obtain a license or permit under the Law.

Copyright 2012 LAPIS Semiconductor Co., Ltd.