

REVISIONS					
REV	ECO	DESCRIPTION	DATE	BY	APPR
A1	-	RELEASE NEW DRAWING	28JUL17	JONY	TOMMY
A2	-	ADD REF P/N & CRIMP TOOL	22/MAR/21	MILO	TOMMY

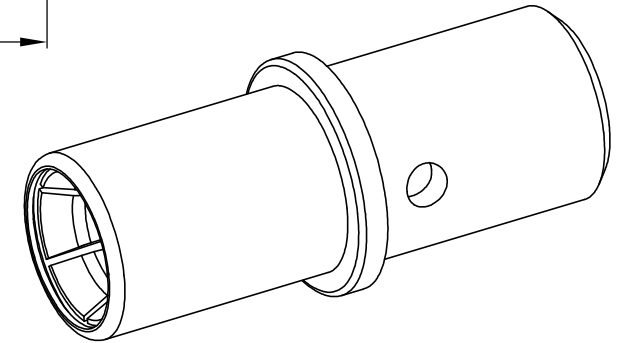
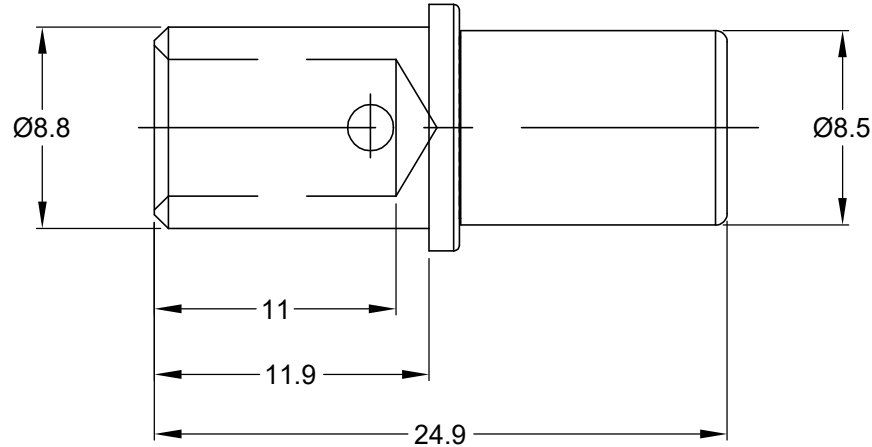
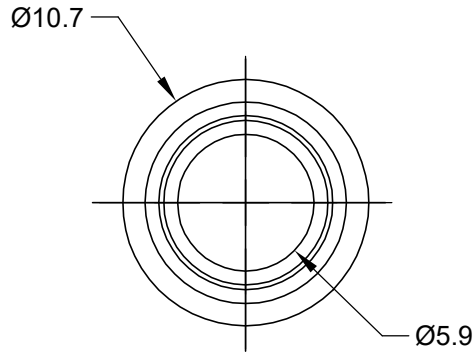

NOTES: UNLESS OTHERWISE SPECIFIED

1. MATERIAL: COPPER ALLOY,NICKEL PLATED
2. CONTACT SIZE: 4#
3. SPECIFICATIONS:
 - 3.1 CURRENT RATING: 100 AMP
 - 3.2 CONTACT MILLIVOLT DROP: 60 MILLIVOLT DROP @ 100 AMP TEST CURRENT.
 - 3.3 ROHS COMPLIANT
4. RECOMMENDED WIRE RANGE: 6 AWG(13mm²)
5. AVAILABLE PNEUMATIC CRIMP TOOL:WA23
6. ALL DIMENSIONS ARE FOR REFERENCE USE ONLY

TITLE: CONTACT SOCKET, SIZE 4, 6 AWG
DWG NO.: AT62-203-04141
REV: A2
SH: 1
QC: 1

AT62-203-04141		REFERENCE:0462-203-04141	
PART NUMBER		DESCRIPTION	
QUANTITY		ITEM	
MATERIALS LIST			
UNLESS OTHERWISE SPECIFIED 1) All dimensions are in metric(mm). 2) Tolerances are as follows: 1 PL DEC ±0.30 2 PL DEC ±0.15 3 PL DEC ±0.08 Fractions ±1/64 Angles ±1° 3) Note reference =		SIGNATURES DRAWN: MILO.DONG 22/MAR/21 CHECKED: ORICALLI 23/MAR/21 ENGINEER: APPROVAL: TOMMY.XIE 24/MAR/21 CUSTOMER:	
MATERIAL SPECIFICATIONS:		<div style="text-align: center;"> <h1>Amphenol</h1> <p>Sine Systems - www.amphenol-sine.com 44724 Morley Drive Clinton Township, MI 48036</p> </div>	
PROCESS SPECIFICATIONS:			
NEXT ASSY:		CONTACT SOCKET, SIZE 4, 6 AWG THIS DRAWING IS SUPPLIED FOR INFORMATION ONLY. DESIGN FEATURES, SPECIFICATIONS AND PERFORMANCE DATA SHOWN HEREON ARE THE PROPERTY OF THE AMPHENOL CORPORATION. NO RIGHTS OF REPRODUCTION ARE IMPLIED. ALL DIMENSIONS ARE SUBJECT TO NORMAL MANUFACTURING VARIATIONS.	
		SIZE: B C- SCALE: NONE	DWG NO.: AT62-203-04141 REVISION: A2 SHEET 1 OF 1