

REVISIONS

P	LTR	DESCRIPTION	DATE	DWN	APVD
	K9	ECR-22-138429	19MAY2022	LP	DSC

**AMP**  
WIRE RANGE

---

22-20 AWG  
STRANDED

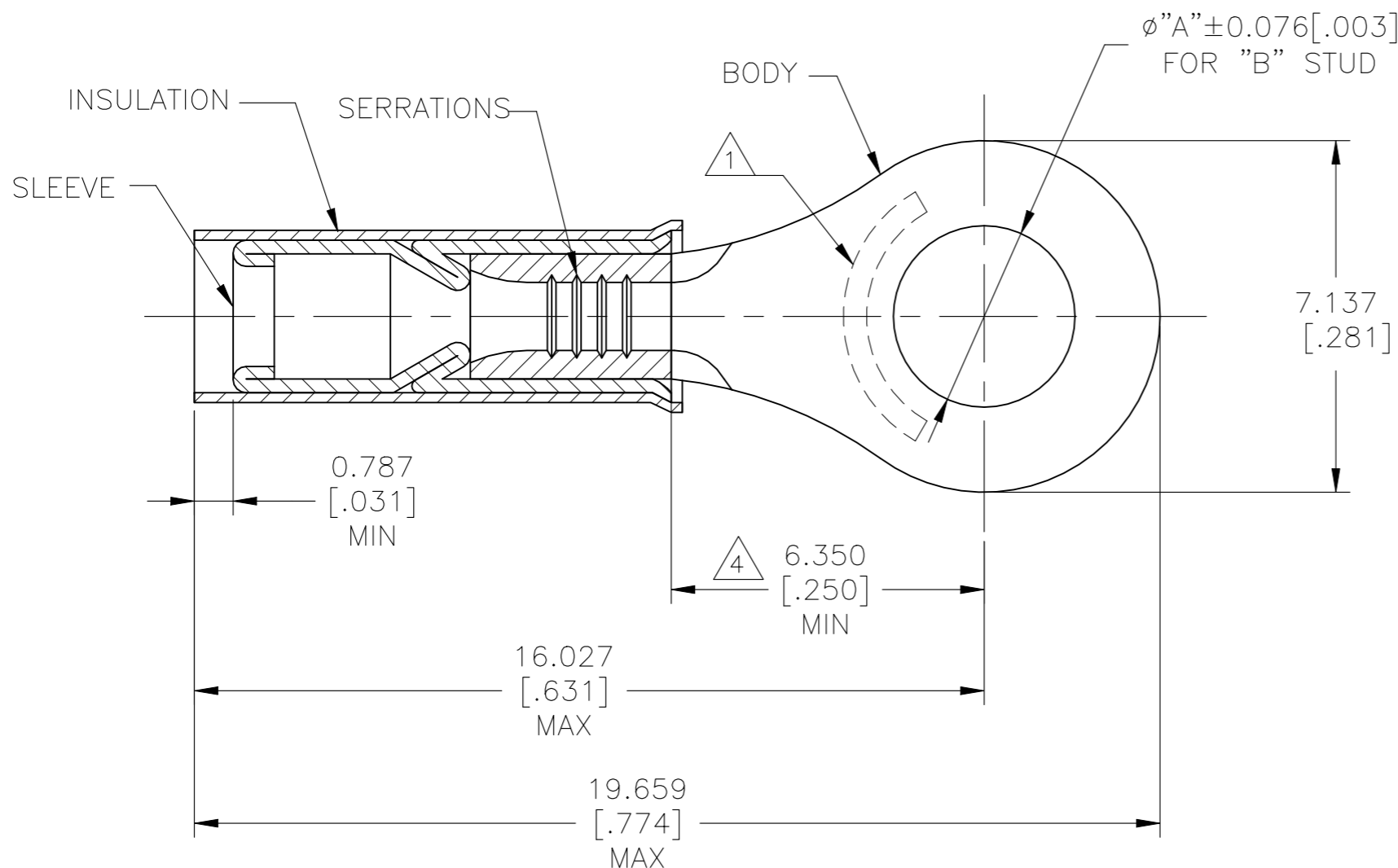

- 1 STAMP AMP 22-20 APPROX AS SHOWN
- 2 FOR 0.889[.035] TO 2.540[.100] WIRE INSULATION DIA
- 3 BODY MATERIAL THK: 0.584±0.051 [.023±.002]
- 4 DIMENSION APPLIES FROM EDGE OF METAL WIRE BARREL TO CENTER OF STUD HOLE.
- 5 MATERIAL:  
BODY & SLEEVE - COPPER PER ASTM B152  
INSULATION - PTFE PER ASTM D4895
- 6 FINISH:  
BODY - NICKEL PLATE 0.00762[.00030]  
AVG EXT THK PER SAE AMS-QQ-N-290  
SLEEVE - NICKEL PLATE 0.001651[.000065]  
AVG EXT THK PER SAE AMS-QQ-N-290  
INSULATION COLOR - GREEN
- 7 NOTE DELETED
- 8 NOTE DELETED
- 9 NOTE DELETED
- 10 NOTE DELETED

M3.5 [#6]	3.683[.145]	1000	LOOSE PIECE	50831-1
#4	3.023[.119]	1000	LOOSE PIECE	50831
"B"	"A"	QTY	PACKAGE TYPE	PART NO.

<b>AMP INCORPORATED CUSTOMER SERVICE SYSTEMS</b>		MAX RECOMMENDED OPERATING TEMPERATURE: 288°C [550°F]	THIS DRAWING IS A CONTROLLED DOCUMENT.		DWN JR RUTH 06AUG07	<b>STE</b> TE Connectivity			
FOR ADDITIONAL PRODUCT INFORMATION OR COPIES OF DRAWINGS AND TECHNICAL DOCUMENTS	PRODUCT INFORMATION CENTER 1-800-522-6752	VOLTAGE RATING: 300V MAX	DIMENSIONS: mm [INCHES]	TOLERANCES UNLESS OTHERWISE SPECIFIED:	CHK T MICHELUTTI 06AUG07				
FOR APPLICATION TOOLING INFORMATION	TOOLING ASSISTANCE CENTER 1-800-722-1111	CIRCULAR MIL AREA: 0.26-0.65mm <sup>2</sup> [509-1,290] STRANDED WIRE ONLY		0 PLC ± - 1 PLC ± - 2 PLC ± - 3 PLC ± 0.127[.005] 4 PLC ± - ANGLES ± -	APVD T MICHELUTTI 06AUG07	PRODUCT SPEC			
FOR ORDER ENTRY	1-800-526-5142		MATERIAL	FINISH	APPLICATION SPEC 114-2162	SIZE	CAGE CODE	DRAWING NO	RESTRICTED TO
					WEIGHT	A3	00779	C-50831	
					CUSTOMER DRAWING	SCALE	8:1	SHEET	1 OF 1
								REV	K9