

A decorative graphic on the left side of the slide, consisting of a stylized circuit board pattern in a light blue color. The pattern is composed of various lines, dots, and geometric shapes that resemble a printed circuit board (PCB) layout, arranged in a roughly circular or semi-circular shape.

# **Richtek** **Wide Input Voltage Range** **DC/DC Power Solution**

Richtek provides comprehensive power conversion solutions for input voltages ranging from 1.4V up to 80V, suitable for a wide range of applications in the industrial, automotive, and professional lighting field.

**RICHTEK**

# Richtek Wide Input Voltage Range DC/DC Power Solutions for Industrial, Automotive and LED lighting applications

Richtek provides comprehensive power conversion solutions for input voltages ranging from 1.4V up to 80V, suitable for a wide range of applications in the industrial, automotive, and professional lighting field. The selected product range in this brochure highlights Richtek linear and switching converters, from low quiescent LDOs to highly efficient step-up and step down converters and controllers, LED lighting drivers, Power Switches and DDR terminators.

- Many parts come with extra features such as **PGOOD** signaling and **programmable Soft-Start**.
- Richtek Buck converters use **robust control architectures like ACOT™** which is compensation free and simple to use.
- The listed parts have **thermally enhanced packages**, allowing higher ambient temperature operation.
- Richtek also offers both **3T parts** (qualified over the full -40°C ~ 85°C industrial temperature range) and Automotive AEC-Q100 qualified parts.
- All parts can be used with **ceramic input and output capacitors** which extends operation life time.

These features make the Richtek parts extremely suitable for demanding applications fields such as:



## Industrial

- eMetering
- Embedded Computing
- Industrial control systems
- Portable equipment
- Instrumentation
- Surveillance Cameras



## Automotive

- Infotainment
- USB Power



## Communications

- Networking
- Servers
- Data storage



## Professional LED Lighting

- Car lighting
- Street Lighting
- Display lighting
- Lighting controls

## Power conversion IC Portfolio for Industrial, Automotive and LED lighting applications

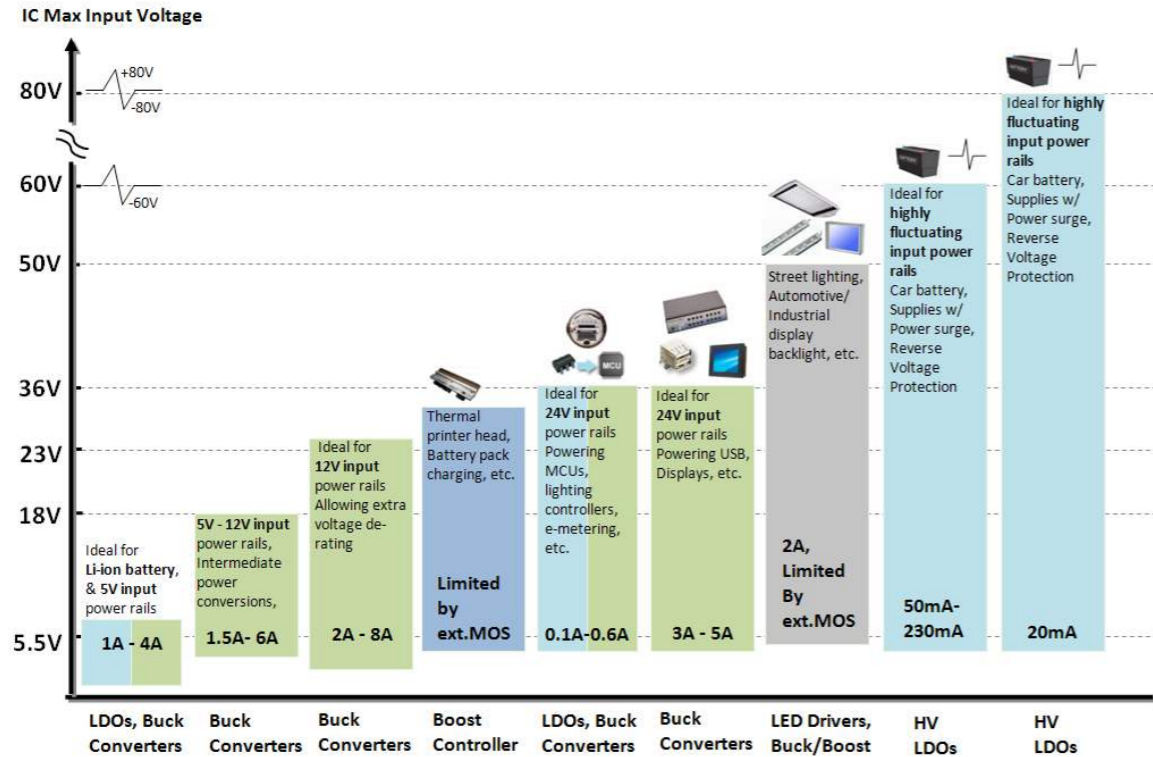

## Step down converters and LDOs

P/N	Description	I <sub>OUT</sub>	V <sub>IN</sub>	V <sub>OUT</sub>	f <sub>sw</sub>	Key features	Package
RT2657BQ	Synchronous Buck converter	0.6A	2.7V~5.5V	0.6V~5.5V	2.25MHz	→ <b>AEC-Q100 Compliance</b> → Built-in Soft-Start → 1.5A Current limit peak	WDFN-8L 3x3
RT5712A		2A	2.7V~5.5V	0.6V~3.4V	1MHz	→ R <sub>ON</sub> 100mΩ HS / 70mΩ LS → 1.2ms fixed Soft-Start → CMCOT topology: good transient response, stable with MLCC → Hiccup or Latch off UVP	WDFN-6L-2x2
RT8079		3A	2.95V~6V	V <sub>REF</sub> : 0.827V	300kHz-2MHz	→ R <sub>ON</sub> 45mΩ HS / 45mΩ LS → Power Good → Adjustable Soft-Start	WQFN-16L-3x3
RT8086B		3.5A	2.8V~5.5V	0.6V~3.3V	1.2MHz	→ R <sub>ON</sub> 50mΩ HS / 40mΩ LS → CMCOT topology: good transient response, stable with MLCC → Power Good → Built-in Soft-Start → Hiccup UVP	UQFN-12L-2x2 (FC)
RT8074		4A	2.7V~5.5V	0.8V~5V	200kHz-2MHz	→ Built-in Soft-Start	PSOP-8

P/N	Description	I <sub>OUT</sub>	V <sub>IN</sub>	V <sub>OUT</sub>	f <sub>sw</sub>	Key features	Package
RT2517B	LDO	1A	2.2V~6V	1.2V~V <sub>IN</sub>	200mV@1A	→ <b>AEC-Q100 Compliance</b> → Low Quiescent 1.5μA in Shutdown Mode	PSOP-8
RT2517C		1A	2.2V~6V	1.2V~V <sub>IN</sub>	150mA@1A	→ <b>3T Grade</b> → Low Quiescent 0.1μA in Shutdown Mode	VDFN-8AL-3x3
RT2518	LDO with EN	1A	1.4V~6V	0.5V~V <sub>IN</sub>	200mV@1A	→ <b>3T Grade</b> → EN control	WDFN-8L-3x3
RT2515H		2A	1.4V~6V	0.5V~V <sub>IN</sub>	400mV@2A	→ <b>3T Grade</b> → EN control	PSOP-8

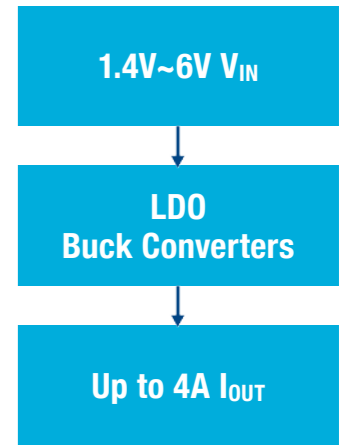

1.4V~6V V<sub>IN</sub>, up to 4A, Buck converters / LDOs, ideal for Li-ion battery powered applications, 5V input power rails and intermediate power conversions.

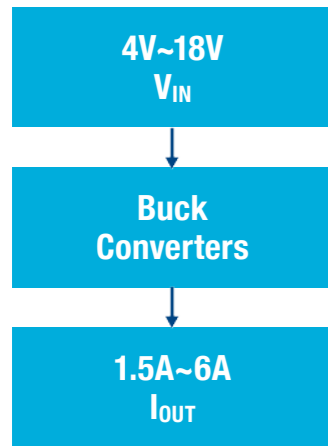

4V~18V VIN, up to 6A Buck converters, ideal for applications powered from 5V~12V power rails, intermediate power conversions, etc.

P/N	Description	I <sub>OUT</sub>	V <sub>IN</sub>	V <sub>OUT</sub>	f <sub>sw</sub>	Key features	Package
RT8297B	Current Mode Synchronous Buck converter	1.5A	4V~17V	0.8V~12V	800kHz	→ Power Good	WDFN-8L-2x2
RT6232/33/A/B A:PSM B:PWM	ACOT™ Synchronous Buck converter	2A/3A	4.5V~18V	0.765V~8V	500kHz	→ ACOT™ topology for ultra-fast transient response and MLCC Cout stable → Adjustable Soft-Start → Power Good → Force PWM or PSM (enhanced light load efficiency)	WDFN-8L-2x3
RT7275/76 75:PWM 76:PSM		3A			700kHz		WDFN-10L-3x3 PTSSOP-14
RT7231/32 31:PWM 32:PSM		4A			650kHz		WDFN-10L-3x3 PTSSOP-14
RT6206B PSM		5.5A			650kHz		WDFN-10L-3x3 PSOP-8
RT2859A/B A:PSM B:PWM	ACOT™ Synchronous Buck converter	3A	4.5V~18V	0.765V~7V	650kHz	→ <b>3T Grade</b> → ACOT™ topology for ultra-fast transient response and MLCC Cout stable → Adjustable Soft-Start → Power Good → Hiccup or Latch off UVP	WDFN-16L-3x3
RT2855A/B A:PSM B:PWM		4A					650kHz
RT2856	Current Mode Synchronous Buck converter	6A	4.5V~18V	V <sub>REF</sub> : 0.8V	200kHz-1.6MHz	→ <b>3T Grade</b> → R <sub>ON</sub> 26mΩ HS / 19mΩ LS → Adjustable Soft-Start → Power Good → V <sub>REF</sub> : 0.8V ±1% over -40° ~ 85°	WQFN-14AL-3.5x3.5

P/N	Description	I <sub>OUT</sub>	V <sub>IN</sub>	V <sub>OUT</sub>	f <sub>sw</sub>	Key features	Package
RT7262/63/64	Current Mode Synchronous Buck converter	2A/3A/4A	4.5V~21V	0.808V~15V	500kHz	→ Synchronized external clock from 300kHz~2MHz → Adjustable Soft-Start → Low LS R <sub>ON</sub> ideal for low V <sub>OUT</sub>	WDFN-14L-4x3 PSOP-8
RT8299		3A	3V~24V	0.8V~15V	500kHz	→ Power Good	WDFN-10L-3x3 PSOP-8
RT6220	ACOT™ Synchronous Buck converter	6A	4.5V~23V	0.6V~5V	500kHz	→ ACOT™ topology for ultra-fast transient response and MLCC COUT stable → R <sub>ON</sub> 31mΩ HS / 20mΩ LS → Power Good	UQFN-16L-3x3(FC)
RT7238	ACOT™ Synchronous Buck converter with 3.3V/5V LDO	8A	8V~23V	0.9V~5V Adj. 3.35V fixed 5.5V fixed	500kHz	→ ACOT™ topology for ultra-fast transient response and MLCC COUT stable → R <sub>ON</sub> 27mΩ HS / 10mΩ LS → With fixed 70mA 3.3V/5V LDO	UQFN-10L-3x3(FC)

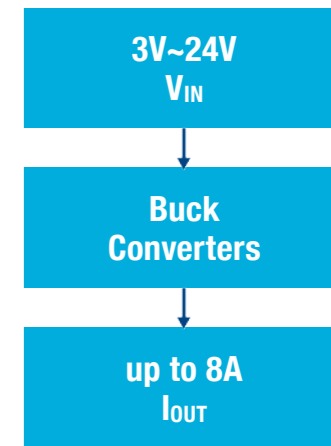

3V~24V VIN, up to 8A Buck converters, ideal for applications powered from 12V system power rails requiring extra input voltage de-rating.

Also see:



Application note:  
Buck converter selection criteria



Application note:  
Comparing Buck converter topologies—  
Current mode, CMCOT™ and ACOT™

3.5V~36V  
 $V_{IN}$

LDOs/Buck  
Converters

0.1A~0.6A  
 $I_{OUT}$

3.5V~36V  $V_{IN}$ , up to 0.6A Buck converters / low quiescent LDOs, ideal for applications from 24V rails, for powering low power MCUs in e-metering, lighting controls, sensors, etc.

P/N	Description	$I_{OUT}$	$V_{IN}$	$V_{OUT}$	fsw	Key features	Package
RT6208	Buck converter	0.1A	4.5V~36V	Adj. $V_{OUT}$ $V_{REF} = 0.8V$		→ Synchronous → Adjustable current limit → 25 $\mu$ A $I_{DQ}$ → Very high efficiency at low load	SOT-23-6 PSOP-8(w/PG) SOT-23-8(w/PG)
RT6200		0.6A	4.5V~36V	0.8V~15V $\pm$ 2%	1.2MHz	→ Asynchronous with internal 0.3 $\Omega$ HS MOSFET	SOT-23-6

P/N	Description	$I_{OUT}$	$V_{IN}$	$V_{OUT}$	fsw	Key features	Package
RT9058 RT2560Q	LDO	100mA	3.5V~36V	2.5V, 3.3V, 5V, 12V fixed	550mV@10mA	→ AEC-Q100 Grade (RT2560Q) → 2 $\mu$ A ultra low $I_{DQ}$	SOT-23-3 SOT-89 PSOP-8

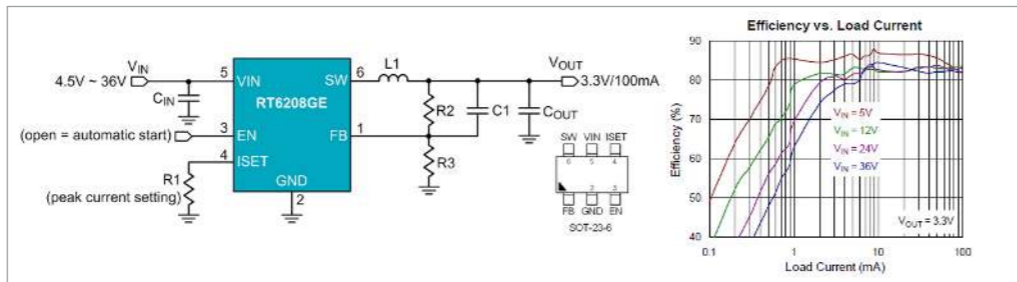

36V low power buck delivering high efficiency from light load to full load conditions.



Also see:  
Application note:  
"How to power small MCU's from industrial supply rails"

P/N	Description	$I_{OUT}$	$V_{IN}$	$V_{OUT}$	fsw	Key features	Package
RT7272A/B (PWM/PSM)	Buck converter	3A	4.5V~36V	0.8V~30V	500kHz	→ Adjustable current limit: 2.5A~5.5A → Integrated 150/80m $\Omega$ HS/LS MOSFET	PSOP-8
RT2872		3A	4.5V~36V	0.8V~30V	300kHz~1MHz	→ AEC-Q100 Grade 3 → 105/80m $\Omega$ HS/LS MOSFET → Ext. compensation	PSOP-8
RT2875A/B (latch UV/hiccup UV)		3A	4.5V~36V	0.6V~24V	300kHz~2.1MHz	→ AEC-Q100 Grade 2 → 95/70m $\Omega$ HS/LS MOSFET → Ext. compensation → Adjustable current limit: 1.5A~6A	PTSSOP-14
RT8289 RT8279		5A	5.5V~36V	1.222V~26V	500kHz	→ Asynchronous with integrated 100m $\Omega$ HS MOSFET → Internal compensation & Soft-Start	PSOP-8
RT2805A		5A	5.5V~36V	1.222V~26V	500kHz	→ 3T Grade → Asynchronous with integrated 110m $\Omega$ HS MOSFET → Internal compensation & Soft-Start	PSOP-8

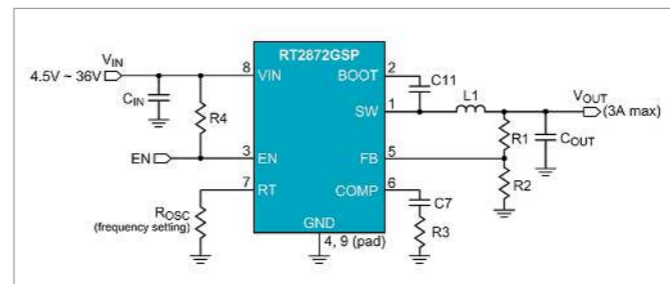

36V/3A buck converter for automotive applications.

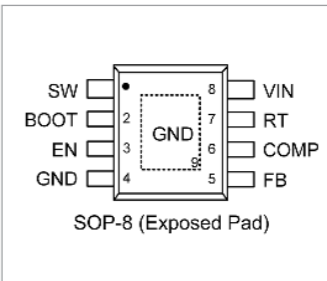

4.5V~36V  
 $V_{IN}$

Buck  
Converters

3A~5A  
 $I_{OUT}$

4.5V~36V  $V_{IN}$ , up to 5A Buck converters, ideal for applications from 24V power rails, such as USB supply, displays, medium power MCUs, Instrumentation, etc.

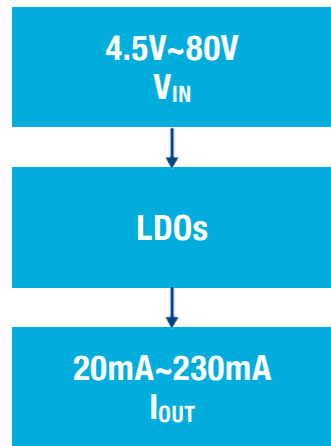

P/N	Description	I <sub>OUT</sub>	V <sub>IN</sub>	V <sub>OUT</sub>	V <sub>Dropout</sub>	Key features	Package
RT2571	LDO	50mA	4.5V~60V	2.5V,3.3V,5V Fixed 1.25~60V Adj.	250mV@50mA	→ 30μA low I <sub>O</sub> → -60V reverse protection	PSOP-8, PMSOP-8, SOT-223
RT9074		100mA	4.5V~60V	2.5V,3.3V,5V Fixed 1.25~60V Adj.	300mV@100mA	→ 30μA low I <sub>O</sub> → -60V reverse protection	PSOP-8, PMSOP-8, SOT-223
RT9068		230mA	4.5V~60V	2.5V,3.3V,5V fixed 1.25V~60V Adj.	230mV@50mA	→ 30μA low I <sub>O</sub> → -60V reverse protection	PSOP-8, PMSOP-8, SOT-223
RT9072A/B		20mA	4.5V~80V	1.25V~60V Adj.	180mV@20mA	→ 23μA low I <sub>O</sub> → -80V reverse protection	SOT-23-5, WDFN-8L 3x3

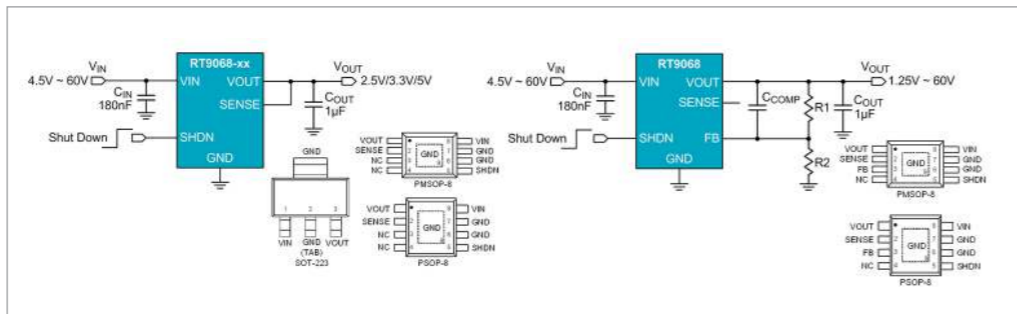

RT9068 high voltage LDO in fixed and adjustable versions.

4.5V~80V V<sub>IN</sub>, up to 230mA.  
High voltage LDOs, ideal for applications from highly fluctuating power rails (±60/±80V) such as automotive battery powered applications, for powering sensors, low power MCUs, etc.

## Step up controller for high power Boost applications

P/N	Description	I <sub>OUT</sub>	V <sub>IN</sub>	V <sub>OUT</sub>	f <sub>sw</sub>	Key features	Package
RT8525	Boost controller	Limited by ext. MOSFET	4.5V~29V	Limited by MOSFET	50K-600kHz	→ Programmable Soft-Start Time → Programmable Boost SW Frequency	SOP-14

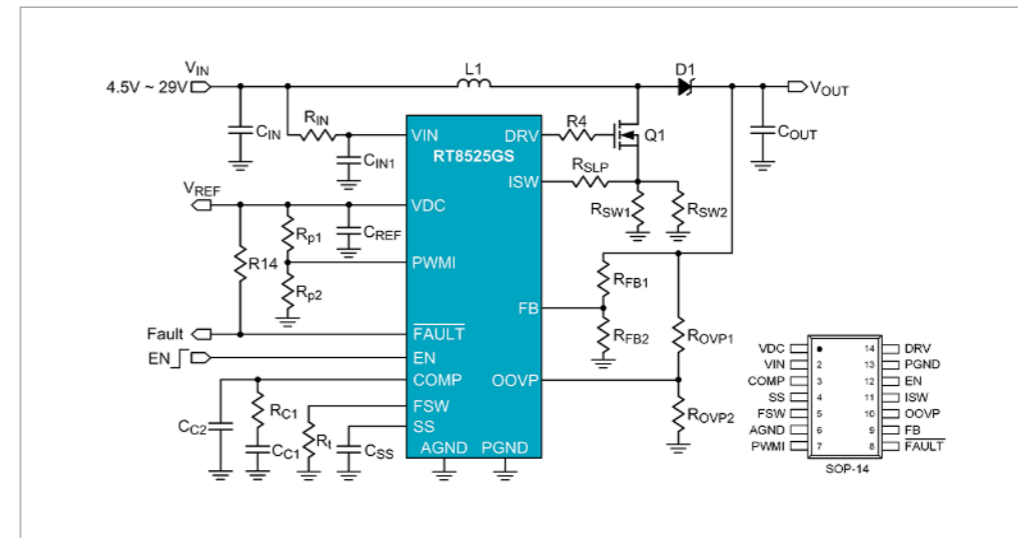

RT8525 Boost controller application for high output powers.

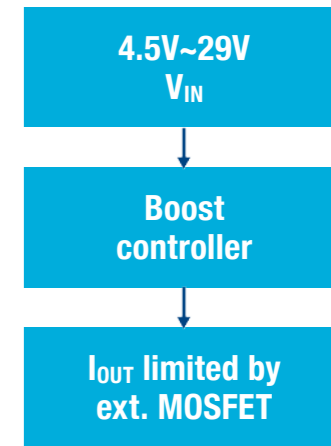

4.5V~29V V<sub>IN</sub>, Boost controller, ideal for applications in high boost power, such as 24V to 48V conversion, large display backlighting, thermal printers, battery pack charging, etc.

# LED Drivers

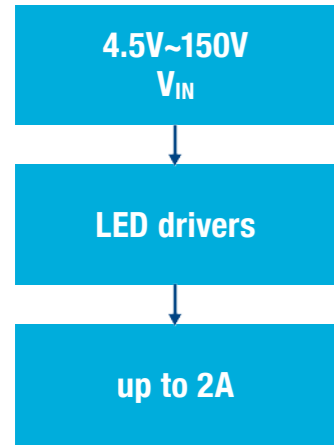

4.5V~150V VIN, Constant Current Buck / Boost / Buck-Boost controllers, ideal for medium power industrial LED lighting applications.

## Constant Current Buck converters

P/N	Description	I <sub>OUT</sub>	V <sub>IN</sub>	Key features	Where to use (application examples)	Package
RT8471	Hysteretic control, high brightness LED driver	1/1.2A	7V~36V	<ul style="list-style-type: none"> <li>Simple application: no C<sub>OUT</sub> needed</li> <li>Analog or digital dimming control</li> <li>Ultra-fast response</li> <li>Colour control for single string</li> </ul>	<ul style="list-style-type: none"> <li>LED strips, signage, &lt; 15W</li> <li>MR-16 ≤ 4W Single string buck with color control via LED gating</li> </ul>	TSOT-23-5 PMSOP-8 PSOP-8
RT8474/A (A:OVP for hot swap function)	50V high voltage LED driver	2A	4.5V~50V	<ul style="list-style-type: none"> <li>Analog or digital dimming control</li> <li>Low R<sub>ON</sub></li> </ul>	<ul style="list-style-type: none"> <li>LED strips, signage, LED engines, P<sub>OUT</sub> &lt; 30W</li> <li>RT8474A with special open string protection is ideal for hot-swap LED string</li> </ul>	PSOP-8

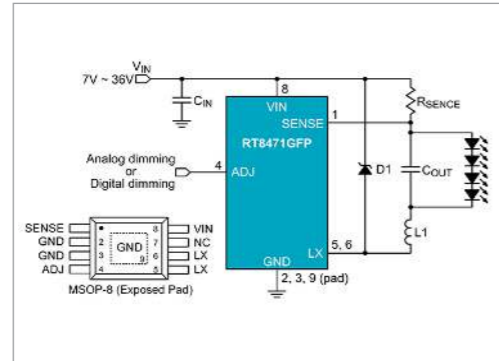

36V / 1A LED driver

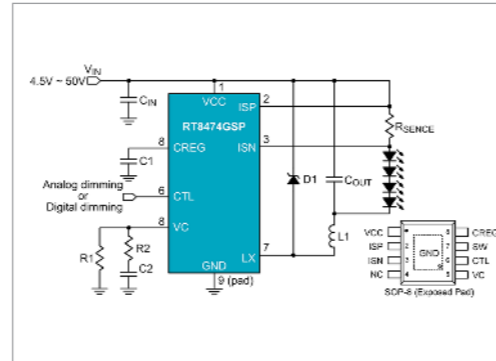

50V / 2A LED driver

## Constant Current Buck / Boost / Buck-Boost controllers

P/N	Description	I <sub>OUT</sub>	V <sub>IN</sub>	V <sub>LED</sub>	Key features	Where to use (application examples)	Package
RT8477A	Buck / Boost controller	Limited by external MOSFET	4.5V~50V	up to 50V	<ul style="list-style-type: none"> <li>low component count</li> <li>Analog or PWM Dimming control</li> </ul>	<ul style="list-style-type: none"> <li>Wide input / output range with medium power: LED modules, down-light, emergency lighting</li> <li>Buck ≤ 60W, Boost ≤ 40W</li> </ul>	PSOP-8
RT8475 / RT8494	LED Driver Controller for Buck / Boost / Buck-Boost Topologies		4.5V~36V (IC V <sub>IN</sub> )	up to 90V	<ul style="list-style-type: none"> <li>Programmable Fsw 100kHz to 1MHz</li> <li>Analog or Digital to Analog Dimming control</li> </ul>	<ul style="list-style-type: none"> <li>Industrial Display Backlight</li> <li><b>AEC-Q100 Compliance (RT8494)</b></li> </ul>	SOP-14, WQFN-16L 3x3
RT8485	LED Driver controller for Buck / Boost / Buck-Boost topologies		4.5V~36V (IC V <sub>IN</sub> )	up to 150V	<ul style="list-style-type: none"> <li>Programmable switching frequency</li> <li>Analog, Digital or Digital to Analog Dimming control</li> </ul>	<ul style="list-style-type: none"> <li>Street lighting</li> <li>High power, high LED string application</li> <li>Buck ≤ 100W, Boost ≤ 80W</li> </ul>	SOP-14

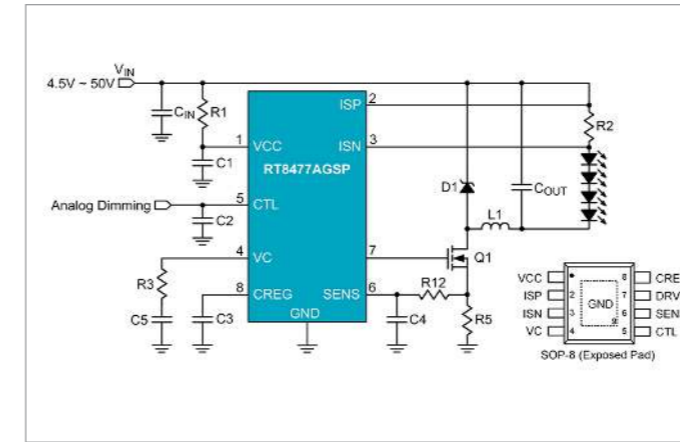

50V high current Buck LED driver

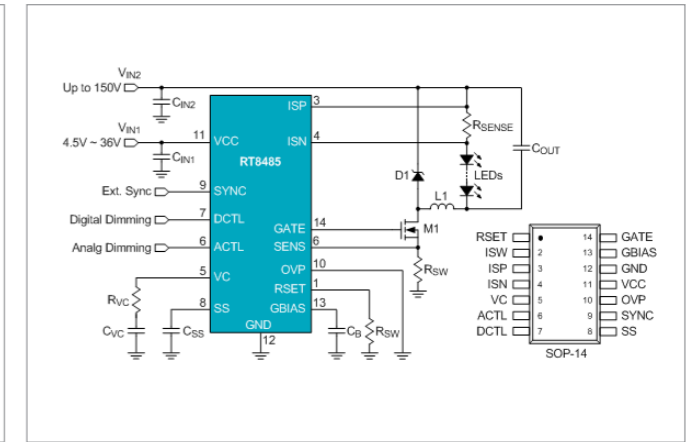

150V High power Buck LED driver

Power Switch and DDR termination regulator

P/N	Description	I <sub>OUT</sub>	V <sub>IN</sub>	Key features	Package
RT2528	Power Switch with adj. Ilim	0.5A~2.5A	2.5V~5.5V	<ul style="list-style-type: none"> <li>→ <b>AEC-Q100 Grade 3</b></li> <li>→ Adjustable current limit: 0.5A~2.5A via an ext. resistance</li> <li>→ 120mΩ P-MOSFET</li> <li>→ Built-in Soft-Start</li> <li>→ Low supply current:120μA</li> <li>→ Reverse input-out voltage</li> </ul>	PSOP-8
RT2526Q	DDR Termination regulator	DDRII/III:2A	V <sub>IN</sub> :3.1V~3.6V VLDOIN:1.2V~1.8V	<ul style="list-style-type: none"> <li>→ <b>3T Grade</b></li> <li>→ S3, S5 off modes</li> <li>→ MLCC stable</li> <li>→ Remote sense</li> </ul>	PSOP-8

---

---

---

---

---

---

---

---

---

---

---

---

---

---

---

---

---

---

---

---

---

---

---

---



Richtek products are sold by description only. Richtek reserves the right to change the circuitry and/or specifications without notice at any time. Customers should obtain the latest relevant information and data sheets before placing orders and should verify that such information is current and complete. Richtek cannot assume responsibility for use of any circuitry other than circuitry entirely embodied in a Richtek product. Information furnished by Richtek is believed to be accurate and reliable. However, no responsibility is assumed by Richtek or its subsidiaries for its use; nor for any infringements of patents or other rights of third parties which may result from its use. No license is granted by implication or otherwise under any patent or patent rights of Richtek or its subsidiaries.



# RICHTEK

**Richtek Technology Corporation** TEL:886-3-5526789 FAX:886-3-5526611 (Headquarters)

Taipei Office

TEL:886-2-89191466

FAX:886-2-89191465

Shanghai Office

TEL:86-21-68798688

FAX:86-21-68798699

Shenzhen Office

TEL:86-755-88353955

FAX:86-755-88353947

Beijing Office

TEL:86-10-64742610

FAX:86-10-64742615

[www.richtek.com](http://www.richtek.com)

