

POSITIONS/ CONTACTS	A		B	
	INCH	MM	INCH	MM
02/02	0.079	2.00	0.177	4.50
03/03	0.157	4.00	0.256	6.50
04/04	0.236	6.00	0.335	8.50
05/05	0.315	8.00	0.413	10.50
06/06	0.394	10.00	0.492	12.50
07/07	0.472	12.00	0.571	14.50
08/08	0.551	14.00	0.650	16.50
09/09	0.630	16.00	0.728	18.50
10/10	0.709	18.00	0.807	20.50
11/11	0.787	20.00	0.886	22.50
12/12	0.866	22.00	0.965	24.50
13/13	0.945	24.00	1.043	26.50
14/14	1.024	26.00	1.122	28.50
15/15	1.102	28.00	1.201	30.50
16/16	1.181	30.00	1.280	32.50
17/17	1.260	32.00	1.358	34.50
18/18	1.339	34.00	1.437	36.50
19/19	1.417	36.00	1.516	38.50
20/20	1.496	38.00	1.594	40.50
21/21	1.575	40.00	1.673	42.50
22/22	1.654	42.00	1.752	44.50
23/23	1.732	44.00	1.831	46.50
24/24	1.811	46.00	1.909	48.50
25/25	1.890	48.00	1.988	50.50
26/26	1.969	50.00	2.067	52.50
27/27	2.047	52.00	2.146	54.50
28/28	2.126	54.00	2.224	56.50
29/29	2.205	56.00	2.303	58.50
30/30	2.283	58.00	2.382	60.50
31/31	2.362	60.00	2.461	62.50
32/32	2.441	62.00	2.539	64.50
33/33	2.520	64.00	2.618	66.50
34/34	2.598	66.00	2.697	68.50
35/35	2.677	68.00	2.776	70.50
36/36	2.756	70.00	2.854	72.50
37/37	2.835	72.00	2.933	74.50
38/38	2.913	74.00	3.012	76.50
39/39	2.992	76.00	3.091	78.50
40/40	3.071	78.00	3.169	80.50

**PART NUMBER CODING**

**xPxNxx1BFLx-M81RC**

**TERMINATION TYPES**

(EVEN NO. OF POSITIONS)  
 C - SMT, SINGLE ROW, PIN 1 LEFT  
 D - SMT, SINGLE ROW, PIN 1 RIGHT

**NUMBER OF POSITIONS**

(CONTACTS PER ROW, 02 THRU 40)

**PLATING**

(.000030" ~ .000050" NICKEL UNDERPLATE)  
 P = GOLD FLASH OVERALL  
 C = .000030" GOLD ON CONTACT SURFACE,  
 .000100" PURE TIN, MATTE ON TERMINATION

**INSULATOR MATERIAL**

N = NYLON 6T  
 OPERATING TEMPERATURE: -40°C TO +105°C  
 PROCESSING TEMPERATURE: WAVE / MANUAL SOLDERING  
 L = LCP  
 OPERATING TEMPERATURE: -40°C TO +125°C  
 PROCESSING TEMP: 260°C MAX FOR 10 SECONDS

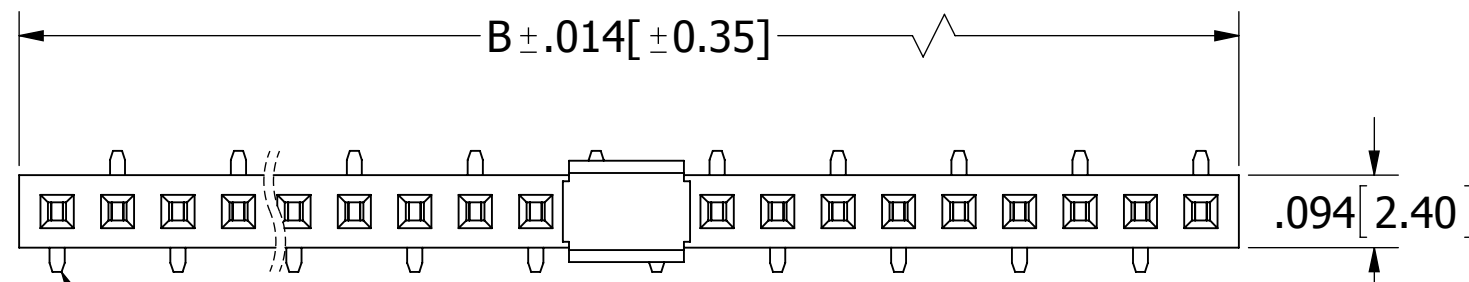

**xPxNxx1BFLD-M81RC  
(OPPOSITE BEND, APPLICABLE ON EVEN COUNTS)**

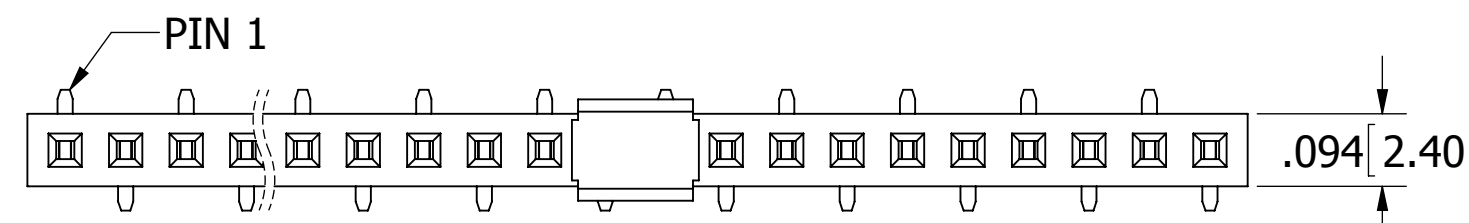

**xPxNxx1BFLC-M81RC  
(STANDARD)**

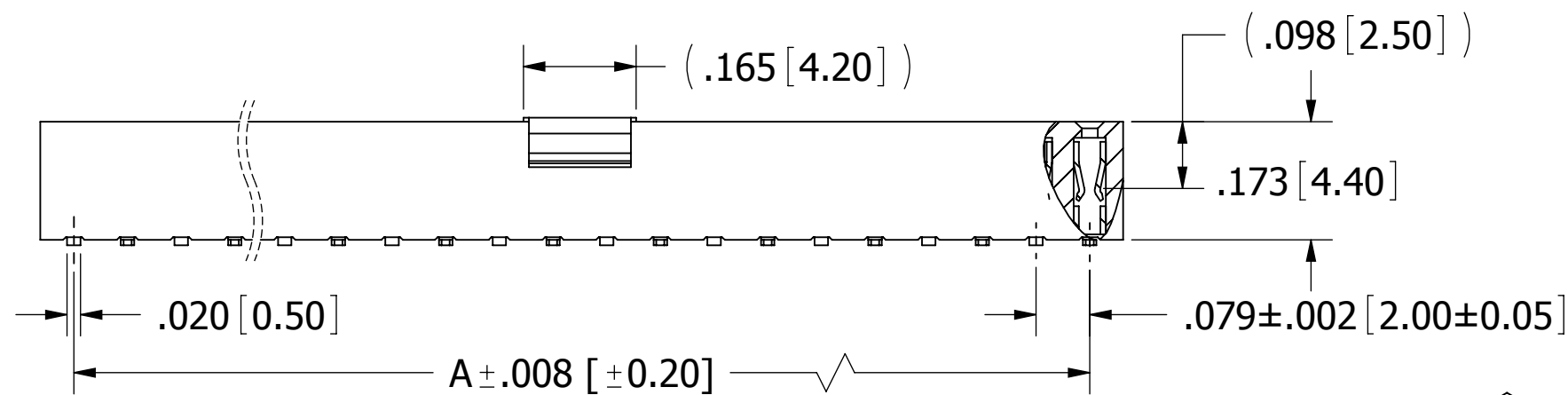

02-20, 0.20mm MAX.  
 21-40, 0.30mm MAX.

REVISIONS				
REV.	ECO. NO	DESCRIPTION	DATE	BY
A	2337	INITIAL RELEASE	08/23/2011	LH
B	2829	ADD INSULATOR MATERIAL "LCP" AND "C" PLATING OPTIONS, UPDATE OPERATING TEMPERATURE AND TAPE AND REEL DIMENSION TABLE	12/10/2014	LH/JHSU

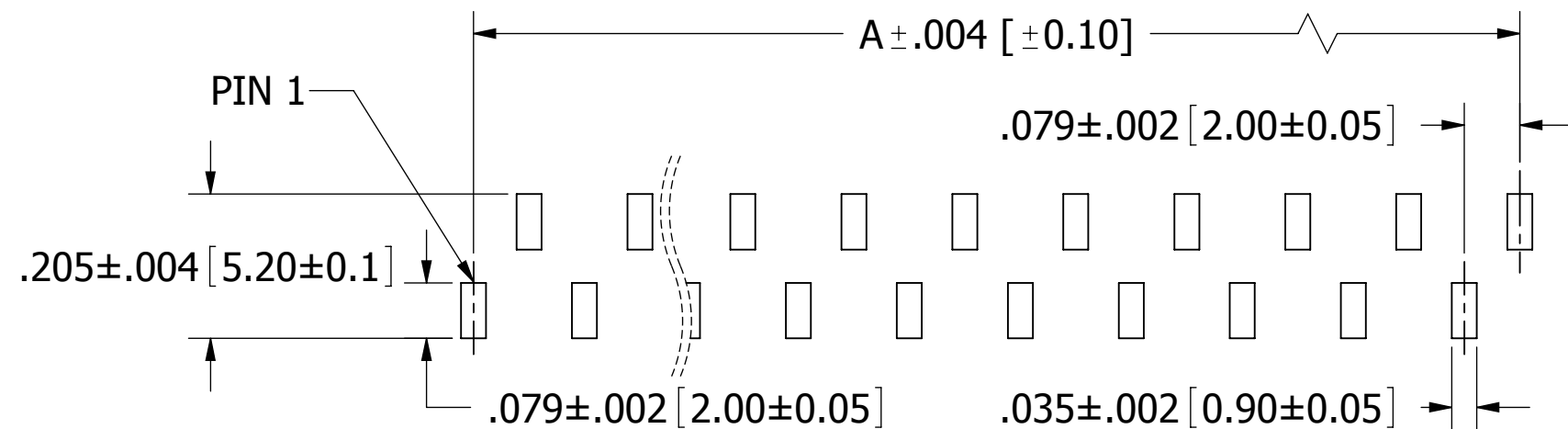

**RECOMMENDED PCB LAYOUT  
xPxNxx1BFLD-M81RC**

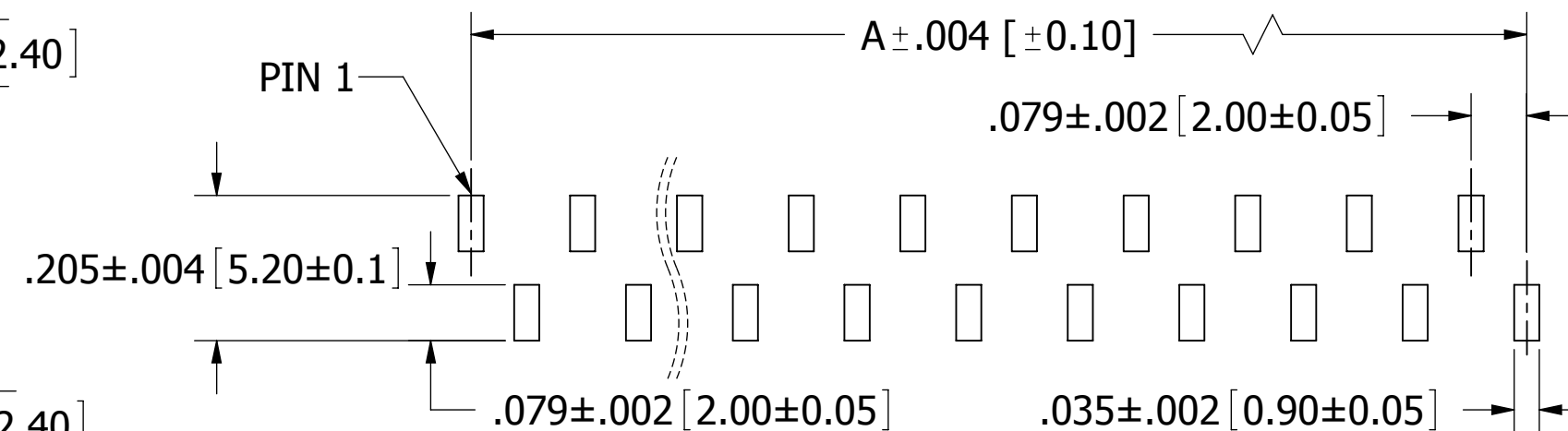

**RECOMMENDED PCB LAYOUT  
xPxNxx1BFLC-M81RC**

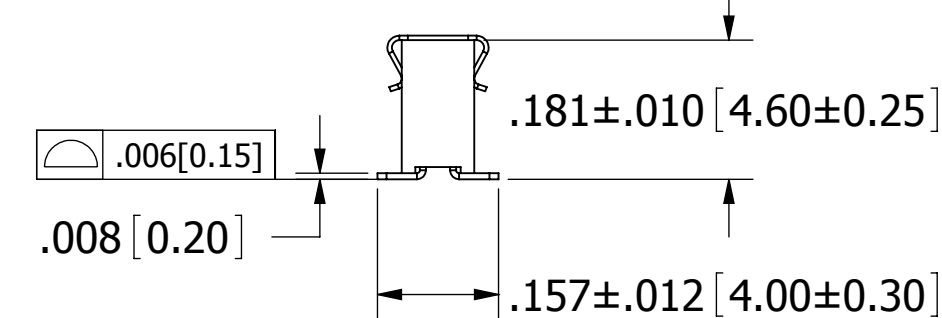

- NOTES:**
- INSULATOR MATERIAL: SEE PART NUMBER CODING, UL 94V-0, BLACK
  - CONTACT MATERIAL: PHOSPHOR BRONZE
  - CONTACT PLATING: SEE PART NUMBER CODING
  - CURRENT RATING: 2 AMPS
  - VOLTAGE RATING: 150V AC/DC
  - INSULATOR RESISTANCE: 1000 MEGOHMS MIN
  - CONTACT RESISTANCE: 20 MILLIOHMS MAX
  - DIELECTRIC WITHSTANDING: 500 VAC
  - OPERATING TEMPERATURE: SEE PART NUMBER CODING
  - PROCESSING TEMP.: SEE PART NUMBER CODING
  - MODIFICATION: WITH PICK AND PLACE CAP IN TAPE & REEL

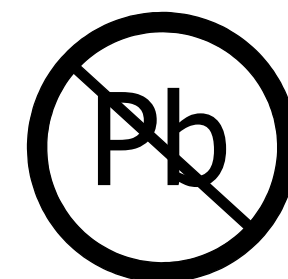

RoHS COMPLIANT

UNLESS OTHERWISE SPECIFIED: DIMENSIONS ARE IN INCHES [MM]		DRAWN	DATE	NAME	
			08/23/2011	LH	
TOLERANCES: ANGULAR: ± 1° DECIMALS .XX = ± .012 [3] .XXX = ± .008 [20] .XXXX = ± .0060 [150]					THE INFORMATION HEREIN CONTAINS PROPRIETARY INFORMATION OF SULLINS ELECTRONICS AND IS NOT TO BE REPRODUCED, USED OR DISCLOSED TO OTHERS FOR ANY PURPOSE EXCEPT AS SPECIFICALLY AUTHORIZED IN WRITING BY AN OFFICER OF SULLINS ELECTRONICS.
TITLE HEADER FEMALE 2.0mm PITCH, 1 ROW, SMT					PART NUMBER <b>xPxNxx1BFLx-M81RC</b>
SIZE	CAGE CODE	DWG. NO.	REV		
C	54453	11780	B		
SCALE: 4:1		SHEET 1 OF 2			

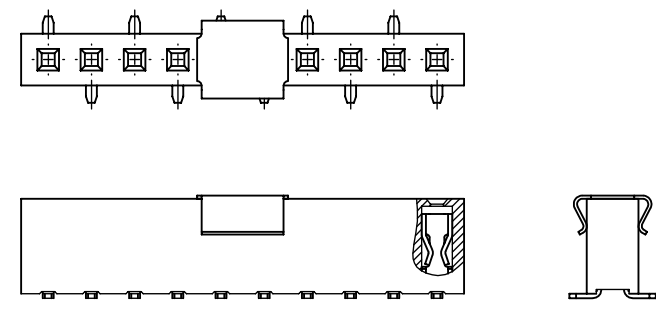

\*\* T & R FOR P/N: xPxNxx1BFLx-M81RC  
(xPxN101BFLC-M81RC AS SHOWN)  
(SEE T & R DIM TABLE AND NOTE 1)

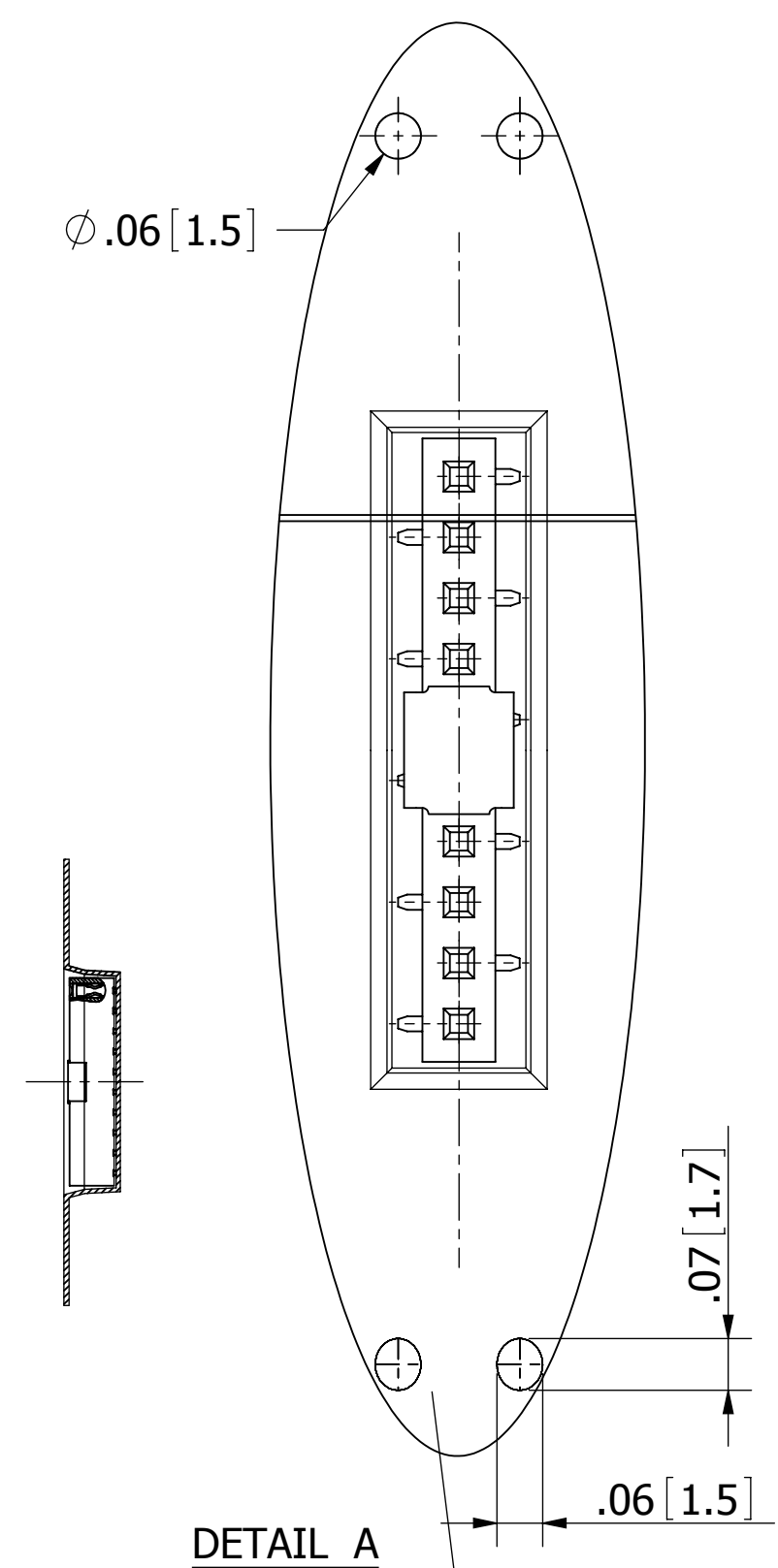
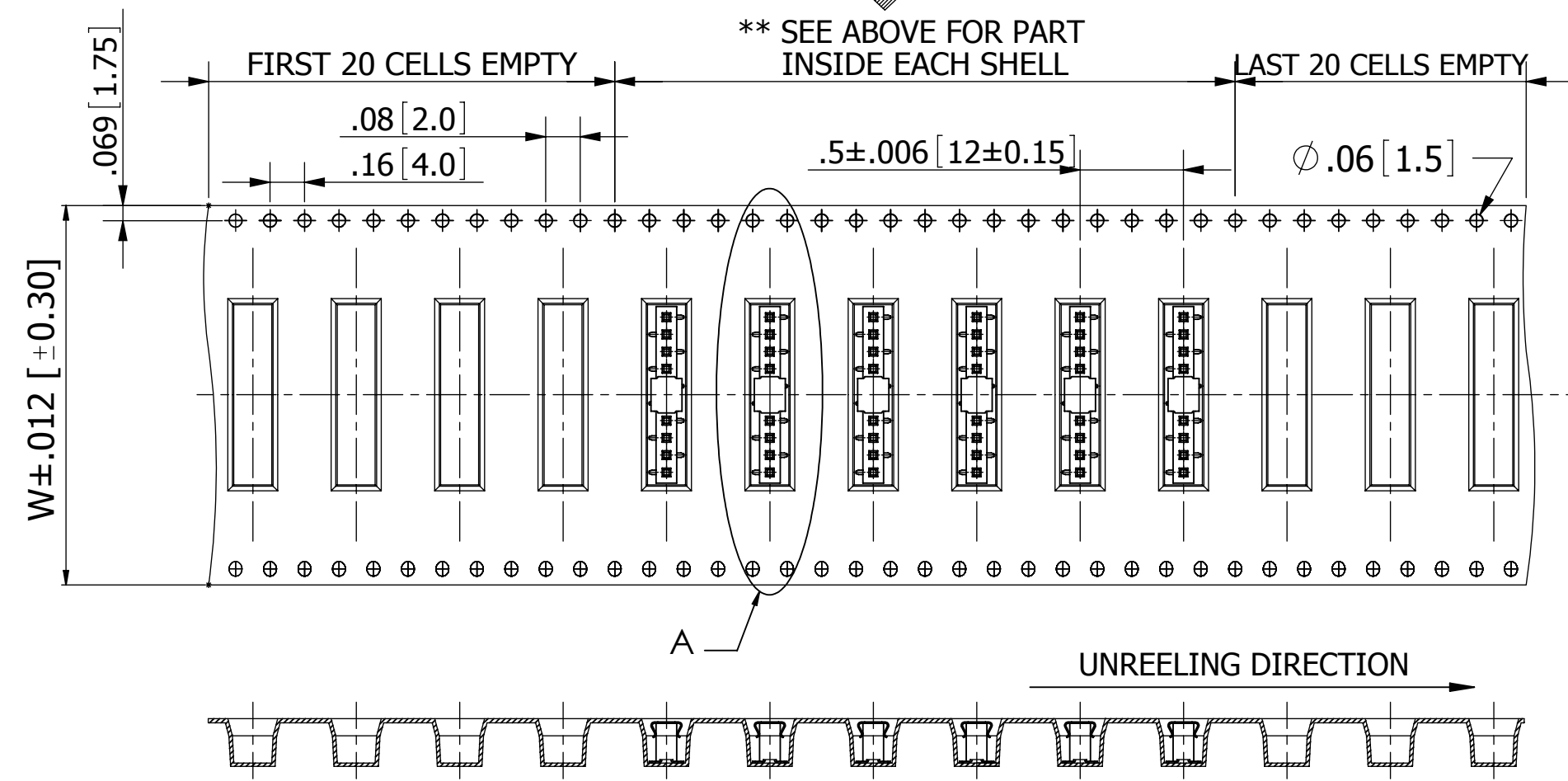

T & R DIMENSION TABLE				
POSITIONS/ CONTACTS	W		A	
	INCH	MM	INCH	MM
02/02 - 03/03	0.630	16.00	0.827	21.00
04/04 - 07/07	0.945	24.00	1.142	29.00
08/08 - 09/09	1.260	32.00	1.457	37.00
10/10 - 15/15	1.732	44.00	1.929	49.00
16/16 - 21/21	2.205	56.00	2.402	61.00
22/22 - 29/29	2.835	72.00	3.031	77.00
30/30 - 37/37	3.465	88.00	3.661	93.00
38/38 - 40/40	4.094	104.00	4.291	109.00

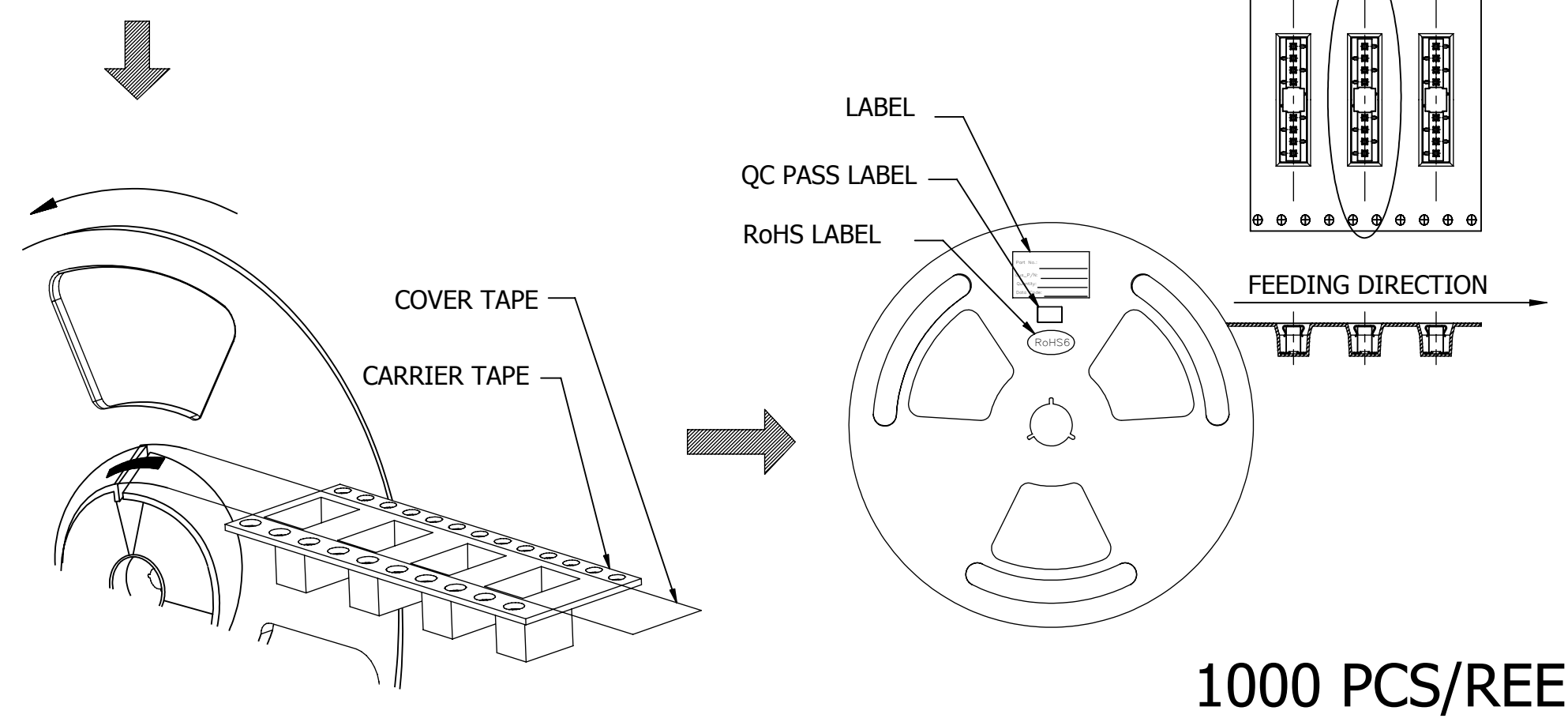
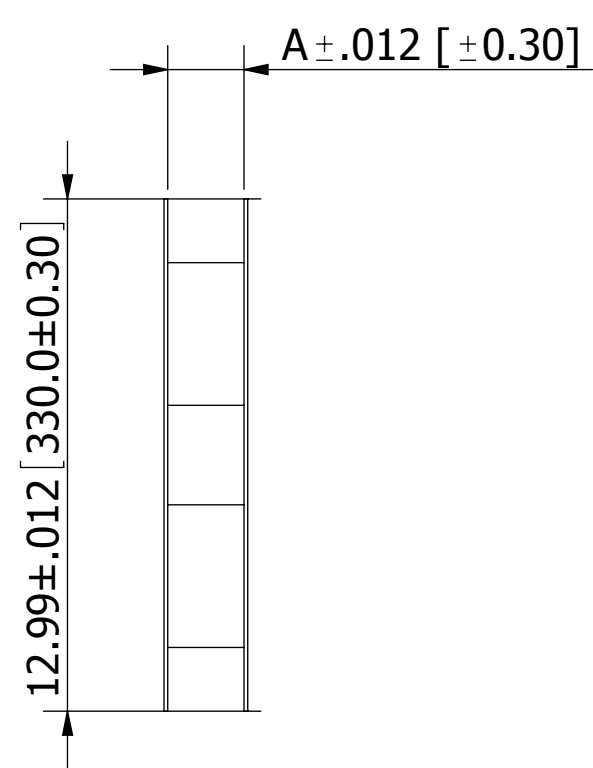

NOTE 1: WHEN THE CARRIER TAPE WIDTH IS EQUAL OR SMALLER THAN 24mm[.945"],  
Ø 1.50mm[.059"] CARRIER HOLES ARE LOCATED ON SINGLE SIDE OF CARRIER TAPE.  
WHEN THE CARRIER TAPE WIDTH IS OVER THAN 24mm[.945"], Ø 1.50mm[.059"]  
CARRIER HOLES ARE LOCATED ON DOUBLE SIDE OF CARRIER TAPE.

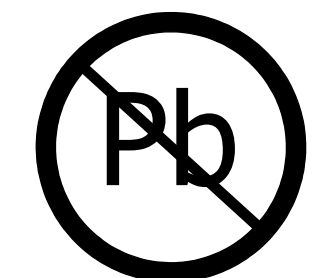

RoHS COMPLIANT

UNLESS OTHERWISE SPECIFIED: DIMENSIONS ARE IN INCHES [MM]	DRAWN	DATE	NAME	
		08/23/2011	LH	
TOLERANCES: ANGULAR: ± 1° DECIMALS .XX= ± .012 [.3] .XXX= ± .008 [.20] .XXXX= ± .0060 [.150]	THE INFORMATION HEREIN CONTAINS PROPRIETARY INFORMATION OF SULLINS ELECTRONICS AND IS NOT TO BE REPRODUCED, USED OR DISCLOSED TO OTHERS FOR ANY PURPOSE EXCEPT AS SPECIFICALLY AUTHORIZED IN WRITING BY AN OFFICER OF SULLINS ELECTRONICS.			TITLE
	HEADER FEMALE 2.0mm PITCH, 1 ROW, SMT PART NUMBER xPxNxx1BFLx-M81RC			REV
	SIZE	CAGE CODE	DWG. NO.	
	C	54453	11780	B
SCALE: 4:1			SHEET 2 OF 2	