

THIS DRAWING IS UNPUBLISHED. RELEASED FOR PUBLICATION NOV., 2004.
 © COPYRIGHT 2004 BY TYCO ELECTRONICS CORPORATION. ALL RIGHTS RESERVED.

LOC	DIST	REVISIONS					
		P	LTR	DESCRIPTION	DATE	DWN	APVD
E	B						
		E		ECR-08-021014	20AUG08	JMS	PB

NOTES

- 1 SINGLE PACK IN ACCORDANCE WITH AMP SPEC 107-3275
- 2 100 TRAY PACK IN ACCORDANCE WITH AMP SPEC 107-3275
- 3 FLASH GOLD PLATING (0.1-0.2µm)
- 4 MEDIUM GOLD PLATING (0.8µm)
- 5 THICK GOLD PLATING (1.3µm)
- 4. HAND CRIMPING TOOL FOR POSITIONS 10-12 TYCO ELECTRONICS P/N 734537-1 (HEX. 3.25) ALTERNATE 9-1478240-0
- 5. HAND CRIMPING TOOL FOR POSITIONS 1-3 DANIELS M22520/2-01 WITH POSITIONER TYCO ELECTRONICS P/N 639000-1, CRIMPING SELECTION: SEL-NO. 4, ALTERNATE 9-1478248-0
- 8. CHARACTERISTICS
 FREQUENCY RANGE: DC-6GHz
 NOMINAL IMPEDANCE: 50 OHMS
 INSULATION RESISTANCE: 1000 MOHMS
 DIELECTRIC WITHSTAND VOLTAGE: 1000V RMS
 WORKING VOLTAGE: 335V MAX AT SEA LEVEL
 CONTACT RESISTANCE:
 CENTRE CONTACT 5.0 mOHMS
 OUTER CONTACT 1.0 mOHMS
- 7. MECHANICAL CHARACTERISTICS
 DURABILITY: 500 CYCLES
- 8. FOR TECHNICAL DATA REFER TO YOUR LOCAL TYCO ELECTRONICS SALES OFFICE
- 9. ALL DIMENSIONS ARE NOMINAL FOR REFERENCE ONLY UNLESS OTHERWISE STATED

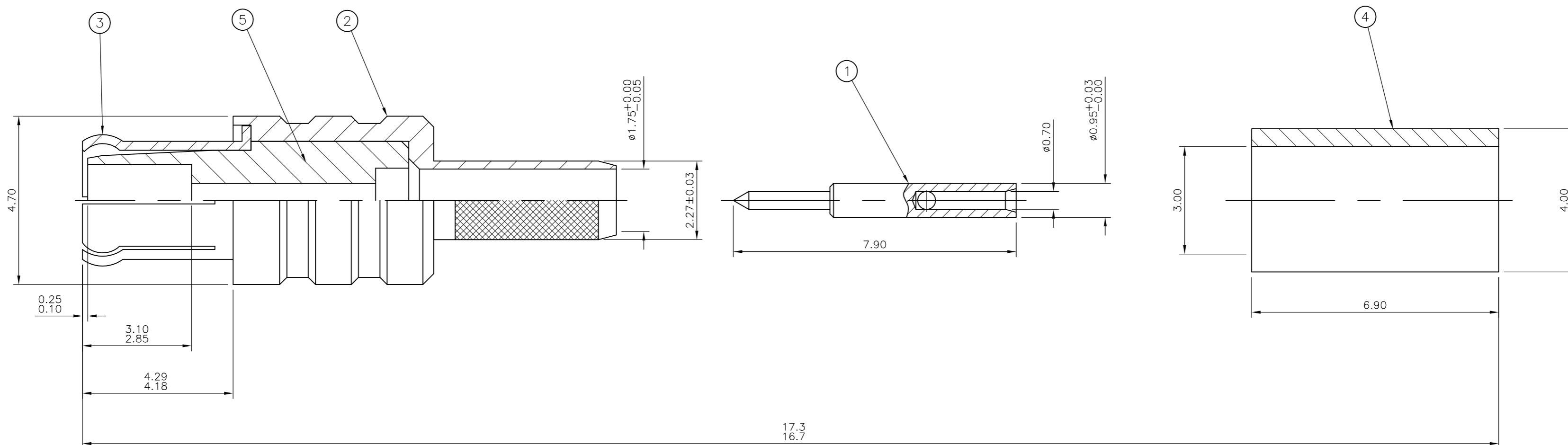

QTY	1	1	1	1	1	1	1	PTFE	DIELECTRIC	5
	1	1	1	1	1	1	1	ANNEALED COPPER	CRIMP SLEEVE	4
	1	1	-	-	-	-	-	PHOSPHOR BRONZE	OUTER CONTACT	3
	-	-	1	1	-	-	-	PHOSPHOR BRONZE	OUTER CONTACT	3
	-	-	-	-	1	1	-	PHOSPHOR BRONZE	OUTER CONTACT	3
	1	1	1	1	1	1	1	BRASS	BODY	2
	1	1	-	-	-	-	-	BRASS	MALE CONTACT	1
	-	-	1	1	-	-	-	BRASS	MALE CONTACT	1
	-	-	-	-	1	1	-	BRASS	MALE CONTACT	1
	6--2	1--2	6--1	1--1	6--0	1--0		MATERIAL	DESCRIPTION	ITEM
	2	1	2	1	2	1				

THIS DRAWING IS A CONTROLLED DOCUMENT.

DWN JSANDWELL 09NOV04	Tyco Electronics Corporation Bideford, EX39 4HE
CHK S.PARLOW 09NOV04	
APVD F.WHEELER-KING 09NOV04	NAME
PRODUCT SPEC	MCX STRAIGHT PLUG CRIMP 50 OHMS RG174, 188, 316, URM95, KX3B, 22A
APPLICATION SPEC	SIZE CAGE CODE DRAWING NO RESTRICTED TO
WEIGHT	A2 00779 C=1337580
CUSTOMER DRAWING	SCALE NTS SHEET 1 OF 2 REV E

THIS DRAWING IS UNPUBLISHED. RELEASED FOR PUBLICATION NOV., 2004.
 © COPYRIGHT 2004 BY TYCO ELECTRONICS CORPORATION. ALL RIGHTS RESERVED.

LOC	DIST	REVISIONS					
E	B	P	LTR	DESCRIPTION	DATE	DWN	APVD
				SEE SHEET 1			

COMPONENTS

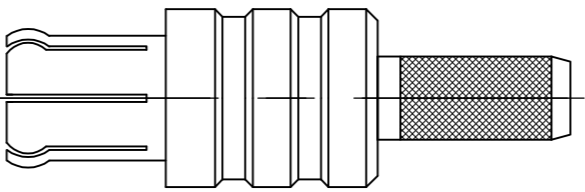
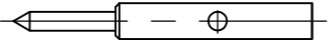
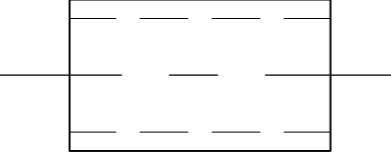
	MAIN BODY (ITEM 2, 3 & 5)	CENTRE CONTACT (ITEM 1)	PUSHER SLEEVE (ITEM 4)		
					

ASSEMBLY INSTRUCTION

CABLES: RG174A/U, 188A/U, 316/U, URM95, KX3B, KX22A

STEP 1

1. SLIDE METAL CRIMP FERRULE OVER CABLE

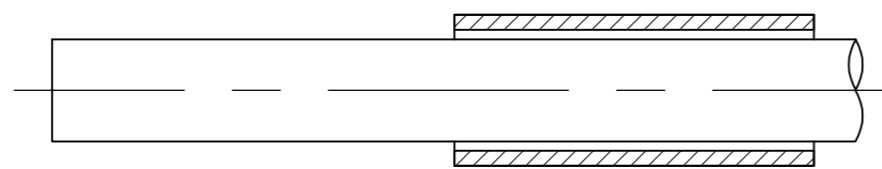

STEP 2

1. STRIP CABLE TO DIMENSIONS AS SHOWN

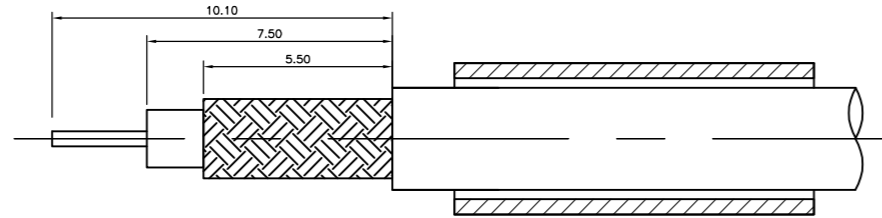

STEP 3

1. FIT CONTACT OVER CENTRE CONDUCTOR TO BUTT AGAINST DIELECTRIC.
2. CRIMP CONTACT USING TOOL AS NOTED ON PAGE 1 NOTE 5

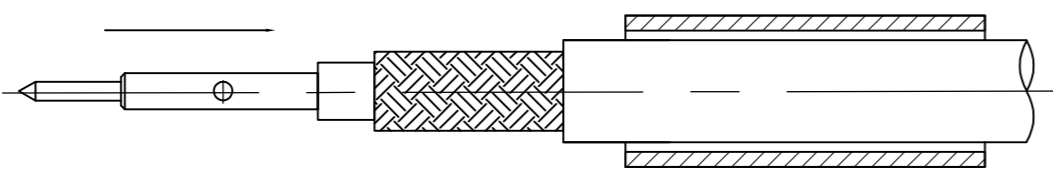

STEP 4

1. PRESS SUB-ASSEMBLY INTO BODY, UNTIL CONTACT IS FULLY LOCATED BY AN AUDIBLE CLICK.
2. ENSURE THAT KNURLED HOUSING INSERTS BETWEEN THE DIELECTRIC AND CABLE BRAID.

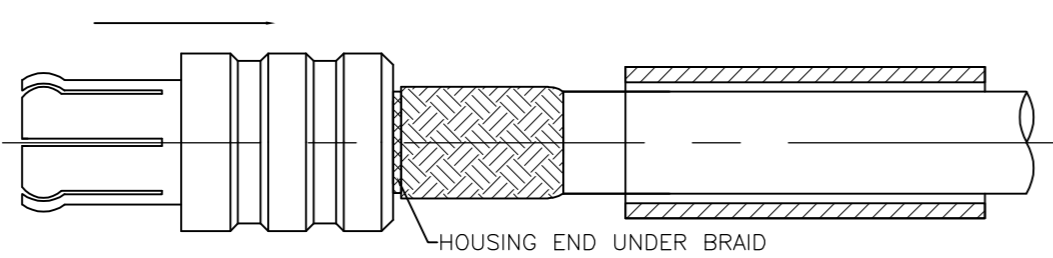

STEP 5

1. SLIDE CRIMP FERRULE ALONG THE CABLE UNTIL IT BUTTS AGAINST THE HOUSING BODY.
2. CRIMP SLEEVE USING TOOL AS NOTED ON PAGE 1 NOTE 4
3. CRIMP DIMENSION AS SHOWN

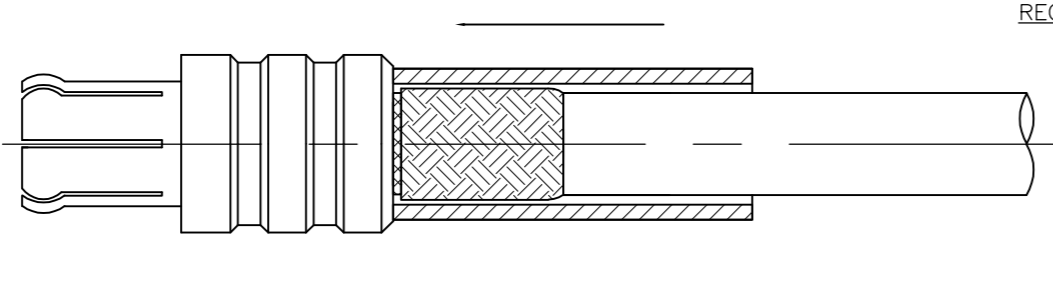

RECOMMENDED CRIMP SLEEVE
A/F HEX

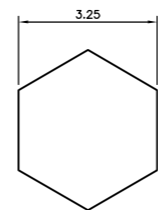

THIS DRAWING IS A CONTROLLED DOCUMENT.

DWN JSANDWELL 09NOV04	 Tyco Electronics Corporation Bideford, EX39 4HE	NAME	MCX STRAIGHT PLUG CRIMP 50 OHMS RG174, 188, 316, URM95, KX3B, 22A
CHK S.PARLOW 09NOV04		SIZE	A2
APVD F.WHEELER-KING 09NOV04		CAGE CODE	00779
PRODUCT SPEC		DRAWING NO	C=1337580
APPLICATION SPEC	RESTRICTED TO		
WEIGHT	SCALE	NTS	SHEET 2 OF 2
CUSTOMER DRAWING	REV	E	

1337580