



**MICROCHIP**

---

**WINC1500 PICtail™ /PICtail  
Plus Daughter Board  
User's Guide**

---

**Note the following details of the code protection feature on Microchip devices:**

- Microchip products meet the specification contained in their particular Microchip Data Sheet.
- Microchip believes that its family of products is one of the most secure families of its kind on the market today, when used in the intended manner and under normal conditions.
- There are dishonest and possibly illegal methods used to breach the code protection feature. All of these methods, to our knowledge, require using the Microchip products in a manner outside the operating specifications contained in Microchip's Data Sheets. Most likely, the person doing so is engaged in theft of intellectual property.
- Microchip is willing to work with the customer who is concerned about the integrity of their code.
- Neither Microchip nor any other semiconductor manufacturer can guarantee the security of their code. Code protection does not mean that we are guaranteeing the product as "unbreakable."

Code protection is constantly evolving. We at Microchip are committed to continuously improving the code protection features of our products. Attempts to break Microchip's code protection feature may be a violation of the Digital Millennium Copyright Act. If such acts allow unauthorized access to your software or other copyrighted work, you may have a right to sue for relief under that Act.

---

Information contained in this publication regarding device applications and the like is provided only for your convenience and may be superseded by updates. It is your responsibility to ensure that your application meets with your specifications. MICROCHIP MAKES NO REPRESENTATIONS OR WARRANTIES OF ANY KIND WHETHER EXPRESS OR IMPLIED, WRITTEN OR ORAL, STATUTORY OR OTHERWISE, RELATED TO THE INFORMATION, INCLUDING BUT NOT LIMITED TO ITS CONDITION, QUALITY, PERFORMANCE, MERCHANTABILITY OR FITNESS FOR PURPOSE. Microchip disclaims all liability arising from this information and its use. Use of Microchip devices in life support and/or safety applications is entirely at the buyer's risk, and the buyer agrees to defend, indemnify and hold harmless Microchip from any and all damages, claims, suits, or expenses resulting from such use. No licenses are conveyed, implicitly or otherwise, under any Microchip intellectual property rights unless otherwise stated.

*Microchip received ISO/TS-16949:2009 certification for its worldwide headquarters, design and wafer fabrication facilities in Chandler and Tempe, Arizona; Gresham, Oregon and design centers in California and India. The Company's quality system processes and procedures are for its PIC® MCUs and dsPIC® DSCs, KEELOQ® code hopping devices, Serial EEPROMs, microperipherals, nonvolatile memory and analog products. In addition, Microchip's quality system for the design and manufacture of development systems is ISO 9001:2000 certified.*

**QUALITY MANAGEMENT SYSTEM  
CERTIFIED BY DNV  
= ISO/TS 16949 =**

**Trademarks**

The Microchip name and logo, the Microchip logo, AnyRate, AVR, AVR logo, AVR Freaks, BeaconThings, BitCloud, CryptoMemory, CryptoRF, dsPIC, FlashFlex, flexPWR, Heldo, JukeBlox, KEELOQ, KEELOQ logo, Klear, LANCheck, LINK MD, maXStylus, maXTouch, MediaLB, megaAVR, MOST, MOST logo, MPLAB, OptoLyzer, PIC, picoPower, PICSTART, PIC32 logo, Prochip Designer, QTouch, RightTouch, SAM-BA, SpyNIC, SST, SST Logo, SuperFlash, tinyAVR, UNI/O, and XMEGA are registered trademarks of Microchip Technology Incorporated in the U.S.A. and other countries.

ClockWorks, The Embedded Control Solutions Company, EtherSynch, Hyper Speed Control, HyperLight Load, IntelliMOS, mTouch, Precision Edge, and Quiet-Wire are registered trademarks of Microchip Technology Incorporated in the U.S.A.

Adjacent Key Suppression, AKS, Analog-for-the-Digital Age, Any Capacitor, AnyIn, AnyOut, BodyCom, chipKIT, chipKIT logo, CodeGuard, CryptoAuthentication, CryptoCompanion, CryptoController, dsPICDEM, dsPICDEM.net, Dynamic Average Matching, DAM, ECAN, EtherGREEN, In-Circuit Serial Programming, ICSP, Inter-Chip Connectivity, JitterBlocker, KlearNet, KlearNet logo, Mindi, MiWi, motorBench, MPASM, MPF, MPLAB Certified logo, MPLIB, MPLINK, MultiTRAK, NetDetach, Omniscient Code Generation, PICDEM, PICDEM.net, PICKit, PICtail, PureSilicon, QMatrix, RightTouch logo, REAL ICE, Ripple Blocker, SAM-ICE, Serial Quad I/O, SMART-I.S., SQT, SuperSwitcher, SuperSwitcher II, Total Endurance, TSHARC, USBCheck, VariSense, ViewSpan, WiperLock, Wireless DNA, and ZENA are trademarks of Microchip Technology Incorporated in the U.S.A. and other countries.

SQTP is a service mark of Microchip Technology Incorporated in the U.S.A.

Silicon Storage Technology is a registered trademark of Microchip Technology Inc. in other countries.

GestIC is a registered trademark of Microchip Technology Germany II GmbH & Co. KG, a subsidiary of Microchip Technology Inc., in other countries.

All other trademarks mentioned herein are property of their respective companies.

© 2017, Microchip Technology Incorporated, All Rights Reserved.

ISBN: 978-1-5224-1666-1

## Object of Declaration: WINC1500 PICtail™/PICtail Plus Daughter Board User's Guide

### EU Declaration of Conformity

This declaration of conformity is issued by the manufacturer.

The development/evaluation tool is designed to be used for research and development in a laboratory environment. This development/evaluation tool is not intended to be a finished appliance, nor is it intended for incorporation into finished appliances that are made commercially available as single functional units to end users. This development/evaluation tool complies with EU EMC Directive 2004/108/EC and as supported by the European Commission's Guide for the EMC Directive 2004/108/EC (8th February 2010). This development/evaluation tool complies with EU RoHS2 Directive 2011/65/EU.

This development/evaluation tool, when incorporating wireless and radio-telecom functionality, is in compliance with the essential requirement and other relevant provisions of the R&TTE Directive 1999/5/EC and the FCC rules as stated in the declaration of conformity provided in the module datasheet and the module product page available at [www.microchip.com](http://www.microchip.com).

For information regarding the exclusive, limited warranties applicable to Microchip products, please see Microchip's standard terms and conditions of sale, which are printed on our sales documentation and available at [www.microchip.com](http://www.microchip.com).

Signed for and on behalf of Microchip Technology Inc. at Chandler, Arizona, USA.

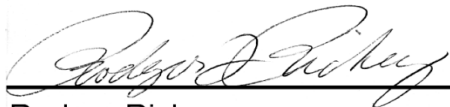

Rodger Richey  
Director of Development Tools



Date

**NOTES:**



# WINC1500 PICTAIL™/PICTAIL PLUS DAUGHTER BOARD USER'S GUIDE

---

---

## Table of Contents

---

---

### Chapter 1. Introduction

1.1 Kit Contents .....	13
1.2 Features .....	13

### Chapter 2. Hardware

2.1 Headers and Connectors .....	15
2.2 Peripherals .....	17

### Chapter 3. Getting Started

3.1 Plugging into PIC18 Explorer Board .....	19
3.2 Plugging into Explorer 16 Development Board .....	20
3.3 Plugging into Explorer 16/32 Development Board .....	21
A.1 Reference Schematics .....	23
B.1 WINC1500 PICtail/PICtail Plus Daughter Board Bill Of Materials .....	27

# WINC1500 PICtail™/PICtail Plus Daughter Board User's Guide

---

---

NOTES:



# WINC1500 PICTAIL™/PICTAIL PLUS DAUGHTER BOARD USER'S GUIDE

## Preface

### NOTICE TO CUSTOMERS

All documentation becomes dated, and this manual is no exception. Microchip tools and documentation are constantly evolving to meet customer needs, so some actual dialogs and/or tool descriptions may differ from those in this document. Please refer to our web site ([www.microchip.com](http://www.microchip.com)) to obtain the latest documentation available.

Documents are identified with a “DS” number. This number is located on the bottom of each page, in front of the page number. The numbering convention for the DS number is “DSXXXXXXXXA”, where “XXXXXXXX” is the document number and “A” is the revision level of the document.

For the most up-to-date information on development tools, see the MPLAB® X IDE online help. Select the Help menu, and then Topics to open a list of available online help files.

## INTRODUCTION

This chapter contains general information that will be useful to know before using the WINC1500 PICtail™/PICtail Plus Daughter Board. Items discussed in this chapter include:

- [Document Layout](#)
- [Conventions Used in this Guide](#)
- [Recommended Reading](#)
- [The Microchip Web Site](#)
- [Development Systems Customer Change Notification Service](#)
- [Customer Support](#)
- [Document Revision History](#)

## DOCUMENT LAYOUT

This document describes how to use the WINC1500 PICtail™/PICtail Plus Daughter Board (also referred as WINC1500 daughter board or daughter board). This user's guide is composed of the following chapters:

- **Chapter 1. “Introduction”** provides an overview of the WINC1500 PICtail/PICtail Plus Daughter Board and its features.
- **Chapter 2. “Hardware”** provides hardware details of the WINC1500 PICtail/PICtail Plus Daughter Board.
- **Chapter 3. “Getting Started”** describes how to start using the WINC1500 PICtail/PICtail Plus Daughter Board.
- **Appendix A. “Schematics”** provides the WINC1500 PICtail/PICtail Plus Daughter Board reference schematics and PCB information.
- **Appendix B. “Bill of Materials”** provides the bill of materials for the components used in the design and manufacture of the WINC1500 PICtail/PICtail Plus Daughter Board.

# WINC1500 PICtail™/PICtail Plus Daughter Board User's Guide

## CONVENTIONS USED IN THIS GUIDE

This manual uses the following documentation conventions:

### DOCUMENTATION CONVENTIONS

Description	Represents	Examples
Italic characters	Referenced books	<i>MPLAB IDE User's Guide</i>
	Emphasized text	...is the <i>only</i> compiler...
Initial caps	A window	the Output window
	A dialog	the Settings dialog
	A menu selection	select Enable Programmer
Quotes	A field name in a window or dialog	"Save project before build"
Underlined, italic text with right angle bracket	A menu path	<u><i>File &gt; Save</i></u>
Bold characters	A dialog button	Click <b>OK</b>
	A tab	Click the <b>Power</b> tab
Text in angle brackets < >	A key on the keyboard	Press <Enter>, <F1>
Plain Courier New	Sample source code	#define START
	Filenames	autoexec.bat
	File paths	c:\mcc18\h
	Keywords	_asm, _endasm, static
	Command-line options	-Opa+, -Opa-
	Bit values	0, 1
	Constants	0xFF, 'A'
<i>Italic Courier New</i>	A variable argument	<i>file.o</i> , where <i>file</i> can be any valid filename
Square brackets [ ]	Optional arguments	mcc18 [options] <i>file</i> [options]
Curly brackets and pipe character: {   }	Choice of mutually exclusive arguments; an OR selection	errorlevel {0 1}
Ellipses...	Replaces repeated text	var_name [, var_name...]
	Represents code supplied by user	void main (void) { ... }
Notes	A Note presents information that we want to re-emphasize, either to help you avoid a common pitfall or to make you aware of operating differences between some device family members. A Note can be in a box, or when used in a table or figure, it is located at the bottom of the table or figure.	<b>Note:</b> This is a standard note box.
		<b>CAUTION</b> <b>This is a caution note.</b> <b>Note 1:</b> This is a note used in a table.



## RECOMMENDED READING

This user's guide describes how to use the WINC1500 PICtail/PICtail Plus Daughter Board. The following Microchip document is available and recommended as supplemental reference resources.

- **WINC1500-MR210PB IEEE 802.11 b/g/n IoT Module Data Sheet (DS70005304)**
- **WINC1500B IEEE 802.11 b/g/n Network Controller SoC Data Sheet**
- **PICDEM™ PIC18 Explorer Demonstration Board User's Guide (DS51721)**
- **Explorer 16 Development Board User's Guide (DS51589)**
- **ATECC508A Product page**
- **WINC1500 PICtail/PICtail Plus Daughter Board Design Package**

## THE MICROCHIP WEB SITE

Microchip provides online support via our web site at: <http://www.microchip.com>. This web site makes files and information easily available to customers. Accessible by most Internet browsers, the web site contains the following information:

- **Product Support** – Data sheets and errata, application notes and sample programs, design resources, user's guides and hardware support documents, latest software releases and archived software
- **General Technical Support** – Frequently Asked Questions (FAQs), technical support requests, online discussion groups, Microchip consultant program member listings
- **Business of Microchip** – Product selector and ordering guides, latest Microchip press releases, listings of seminars and events; and listings of Microchip sales offices, distributors and factory representatives

## DEVELOPMENT SYSTEMS CUSTOMER CHANGE NOTIFICATION SERVICE

Microchip's customer notification service helps keep customers current on Microchip products. Subscribers will receive e-mail notification whenever there are changes, updates, revisions or errata related to a specified product family or development tool of interest.

To register, access the Microchip web site at [www.microchip.com](http://www.microchip.com), click on Customer Change Notification and follow the registration instructions.

The Development Systems product group categories are:

- **Compilers** – The latest information on Microchip C compilers and other language tools
- **Emulators** – The latest information on the Microchip in-circuit emulator, MPLAB REAL ICE™
- **In-Circuit Debuggers** – The latest information on the Microchip in-circuit debugger, MPLAB ICD 3
- **MPLAB X IDE** – The latest information on Microchip MPLAB X IDE, the Windows® Integrated Development Environment for development systems tools
- **Programmers** – The latest information on Microchip programmers including the PICkit™ 3 development programmer

## CUSTOMER SUPPORT

Users of Microchip products can receive assistance through several channels:

- Distributor or Representative
- Local Sales Office
- Field Application Engineer (FAE)
- Technical Support

Customers should contact their distributor, representative or Field Application Engineer (FAE) for support. Local sales offices are also available to help customers. A listing of sales offices and locations is included in the back of this document.

Technical support is available through the web site at: <http://support.microchip.com>.

## DOCUMENT REVISION HISTORY

### Revision A (May 2017)

This is the initial released version of this document.

# WINC1500 PICtail™/PICtail Plus Daughter Board User's Guide

---

---

NOTES:



# WINC1500 PICTAIL™/PICTAIL PLUS DAUGHTER BOARD USER'S GUIDE

## Chapter 1. Introduction

Thank you for purchasing a WINC1500 PICTail™/PICTail Plus Daughter Board. This document provides detailed information about the Microchip Technology WINC1500 PICTail/PICTail Plus Daughter Board.

The WINC1500 PICTail/PICTail Plus Daughter Board is a demonstration and development board for the WINC1510-MR210PB certified Wi-Fi module.

This daughter board has PICTail and PICTail Plus connectors to interface with a PIC microcontroller on the development boards that supports either PICTail or PICTail Plus interface. The daughter board can be plugged into multiple Microchip Technology demonstration and development boards. For example, the daughter board is appropriate for 8-bit microcontroller development using the PIC18 Explorer Board or for 16-bit microcontroller development using Explorer 16 Development Board.

The supporting software stacks and application notes are available for download from the Microchip web site at:

[www.microchip.com/mplab/mplab-harmony/mplab-harmony-2-0-2](http://www.microchip.com/mplab/mplab-harmony/mplab-harmony-2-0-2).

### CAUTION

Power to the WINC1500 PICTail/PICTail Plus Daughter Board must be in the range of 3.0V to 3.6V. Ensure that the daughter board is plugged into a development/demonstration board that meets the voltage requirement; otherwise, damage to the WINC1500 board may occur.

This chapter includes the following topics:

[1.1 “Kit Contents”](#)

[1.2 “Features”](#)

### 1.1 KIT CONTENTS

The WINC1500 PICTail/PICTail Plus Daughter Board kit contains the following:

- One WINC1500 PICTail/PICTail Plus Daughter Board, which contains the ATWINC1510-MR210PB module

### 1.2 FEATURES

The following are the key features of the WINC1500 PICTail/PICTail Plus Daughter Board:

- Option to switch power source between the USB and PICTail/PICTail Plus interface base board
- The UART debug interface of the WINC1500 daughter board can be directly accessed from the PC through the USB header (J7)
- User LEDs for indications
- Power measurement header
- I<sup>2</sup>C debug header for RF validation
- GPIO debug header

# WINC1500 PICtail™/PICtail Plus Daughter Board User's Guide

Figure 1-1 illustrates the top view of the WINC1500 PICtail/PICtail Plus Daughter Board with the following components:

1. ATWINC1510-MR210PB module (U1)
2. MCP2200 (U2)
3. ATECC508A Crypto IC (U4)
4. I<sup>2</sup>C debug header (J1)
5. GPIO debug header (J4)
6. PICtail header (J5)
7. PICtail Plus connector (J2)
8. Power selection connector (J8)
9. Power measurement connector (J6)
10. UART debug header (J3)

For additional information on these features, refer to [Chapter 2. "Hardware"](#).

**FIGURE 1-1: WINC1500 PICTAIL/PICTAIL PLUS DAUGHTER BOARD (TOP VIEW)**

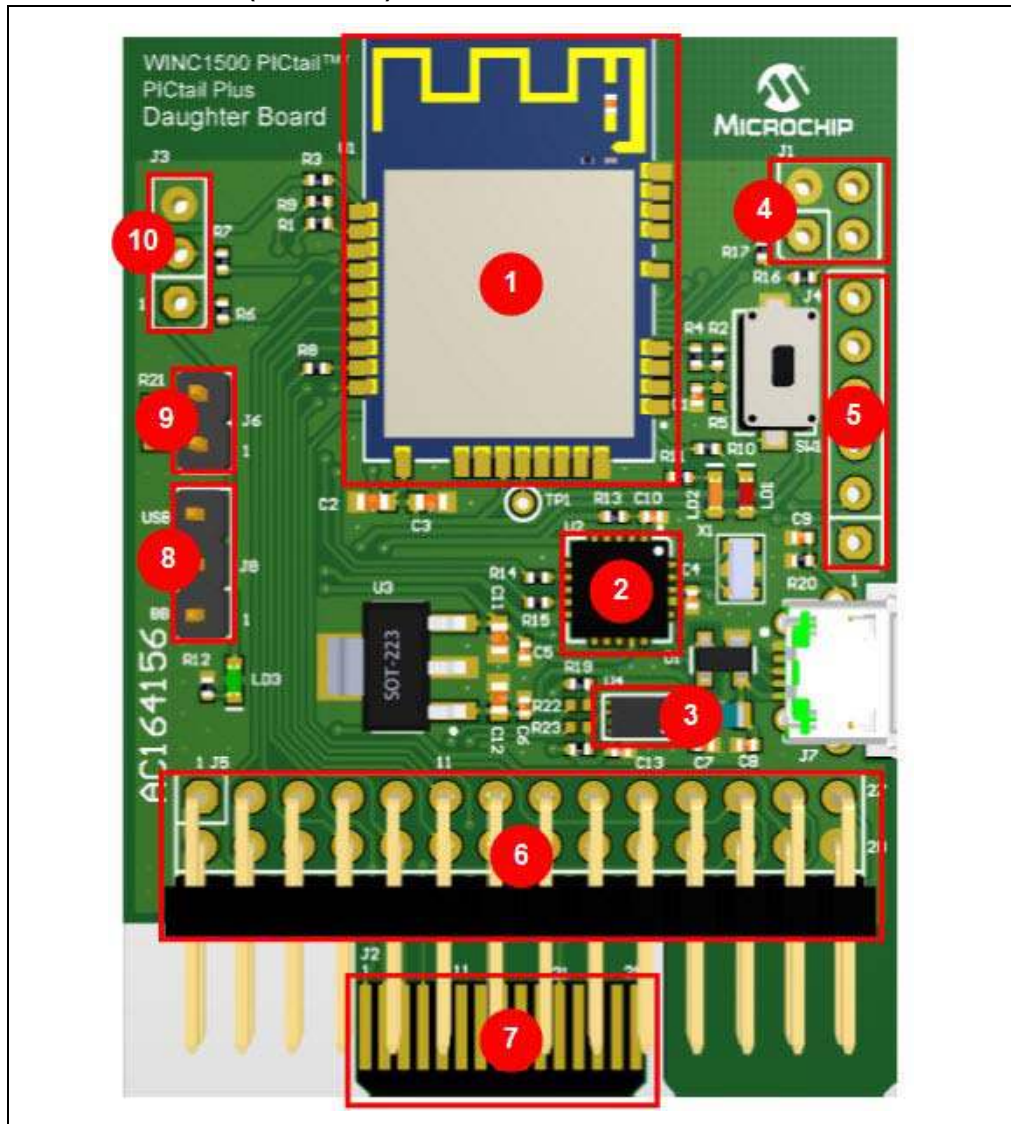

## Chapter 2. Hardware

This chapter describes the hardware features of the WINC1500 PICTail/PICTail Plus Daughter Board.

### 2.1 HEADERS AND CONNECTORS

This section provides the details of each component on the WINC1500 PICTail/PICTail Plus Daughter Board. For the location of these components, see [Figure 1-1](#).

#### 2.1.1 PICTail Plus Connector (J2)

The WINC1500 PICTail/PICTail Plus Daughter Board has a 30-pin card edge connector to interface with 16-bit and 32-bit development board's PICTail Plus connector, refer to [Table 2-1](#).

#### 2.1.2 PICTail Connector (J5)

The WINC1500 PICTail/PICTail Plus Daughter Board has a 28-pin right angle connector to interface with the 8-bit development board's PICTail Plus connector.

[Table 2-1](#) provides the pinout details of the PICTail/PICTail Plus connectors.

**TABLE 2-1: PICTAIL/PICTAIL PLUS CONNECTOR PINOUT**

Pin on PICTail Plus 30-pin connector (J2)	Pin on PICTail 28-pin connector (J5)	Pin on ATWINC1510-MR210PB	Function
28	25	4	ATWINC1500 RESET
14	11	11	ATWINC1500 WAKE
18	27	13	ATWINC1500 IRQ
30	23	22	ATWINC1500 CHIP ENABLE
1	24	16	SPI_SS
7	8	15	SPI_MOSI
5	10	17	SPI_MISO
3	12	18	SPI_SCK
9,10,15,16	28	9,12, 28	GND
22	26	20, 23 <sup>(1)</sup>	Vcc

**Note 1:** The Vcc of the base board is connected to the Vcc of the module through a power selection connector when jumper is placed on the 1-2 of the header (J8).

## 2.1.3 I<sup>2</sup>C Debug Header (J1)

The WINC1500 PICtail/PICtail Plus Daughter Board has an UART debug header which connects the I<sup>2</sup>C debug interface to the ATWINC1510-MR210PB module. This header is not populated. [Table 2-2](#) provides the pinout details of the I<sup>2</sup>C debug header.

**TABLE 2-2: I<sup>2</sup>C DEBUG HEADER PINOUT**

Pin on I <sup>2</sup> C debug header (J1)	Pin on ATWINC1510-MR210PB	Function
1	2	ATWINC1500 SCL
2	9, 12, 28	GND
3	3	ATWINC1500 SDA
4	—	No connection

## 2.1.4 GPIO Debug Header (J4)

The WINC1500 PICtail/PICtail Plus Daughter Board has an UART debug header which connects the GPIO debug interface to the ATWINC1510-MR210PB module. This header is not populated. [Table 2-3](#) provides the pinout details of the GPIO debug header.

**TABLE 2-3: GPIO DEBUG HEADER PINOUT**

Pin on GPIO debug header (J4)	Pin on ATWINC1510-MR210PB	Function
1	11	ATWINC1500 WAKE
2	21	ATWINC1500 GPIO_1
3	25	ATWINC1500 GPIO_3
4	26	ATWINC1500 GPIO_4
5	27	ATWINC1500 GPIO_5
6	1	ATWINC1500 GPIO_6

## 2.1.5 UART Debug Header (J3)

The WINC1500 PICtail/PICtail plus daughter board has an UART debug header which connects the UART debug interface to the ATWINC1510-MR210PB module. This header is not populated. [Table 2-4](#) provides the pinout of the UART debug header.

**TABLE 2-4: UART DEBUG HEADER PINOUT**

Pin on I <sup>2</sup> C debug header (J1)	Pin on ATWINC1510-MR210PB	Function
1	19	ATWINC1500 UART RX
2	14	ATWINC1500 UART TX
3	9,12, 28	GND



## 2.1.6 Power Source Selection Connector (J8)

The jumper header J8, on the WINC1500 PICtail/PICtail Plus Daughter Board, is used to select power source for the daughter board. The daughter board can be powered either from the power supply of the base board or from the external USB supply.

Mounting the jumper in position 1-2 (pin 1 marked with overlay “BB” in the PCB) will power the daughter board from the base board, and mounting the jumper in position 2-3 (pin 3 marked with overlay “USB” in the PCB) will power the daughter board from the USB supply.

When the daughter board is powered from the external USB supply, it can still be interfaced to any base board with the PICtail/PICtail Plus connectors. The GND for the PICtail daughter board and base board are common, and the both will operate at 3.3V. A 5V input from the USB supply is provided to LDO (U3) to obtain the 3.3V for supplying the daughter board.

## 2.1.7 Power Measurement Header (J6)

The jumper header J6, on the WINC1500 PICtail/PICtail Plus Daughter Board, can be used to measure the current consumption of the ATWINC1510-MR210PB module. The power to the ATWINC1510-MR210PB module is routed through this header.

To measure the current consumption of the module, connect a voltmeter directly across the pins of J6. A 1Ω resistor is connected in parallel with the jumper header J6 which provides 1:1 relationship between the voltage and current measured across the jumper.

## 2.2 PERIPHERALS

### 2.2.1 USB-to-UART Serial Converter (U2)

The WINC1500 PICtail/PICtail Plus Daughter Board has an on-board USB-to-UART serial bridge/converter, which is used for observing UART debug logs from the ATWINC1510-MR210PB module. The PC console can be connected to the daughter board using a standard-A to micro-B or micro-AB cable.

The following UART configuration to be used in the PC console:

- Baud rate: 115200
- Data: 8 bit
- Parity: None
- Stop bit: 1
- Flow control: None

### 2.2.2 User LED

Two user LEDs are available on the WINC1500 PICtail/PICtail Plus Daughter Board which can be turned ON and OFF. The LED can be activated by driving the connected I/O line to GND. [Table 2-5](#) provides the pinout details of the user LEDs.

**TABLE 2-5: USER LED PINOUT**

LED	Pin on ATWINC1510-MR210PB	Function
LD1	1	ATWINC1500 GPIO_6 Red LED
LD2	27	ATWINC1500 GPIO_5 Orange LED

## 2.2.3 Power LED (LD3)

A power indication LED on the WINC1500 PICtail/PICtail Plus Daughter Board. This LED will be ON when the daughter board is provided with an adequate power supply.

## 2.2.4 Crypto Device - ATECC508A (U4)

The WINC1500 PICtail/PICtail Plus Daughter Board contains a ATECC508A Crypto authentication device. The I<sup>2</sup>C pins required for interfacing with the ATECC508A device is connected only to the PICtail Plus connector. The ATECC508A device is interfaced with the host MCU through 0R resistors, R22 and R23.

The 0R resistors are not mounted in the Rev 1 of the board and users need to solder these pads. These resistors are mounted from the Rev 1.2 of the board. The revision of the board could be found from the text in the bottom copper layer "04-10608 REV X.X", where X.X indicates the revision of the board.

[Table 2-6](#) provides the pinout details of the Crypto device.

**TABLE 2-6: CRYPTO DEVICE- ATECC508A PINOUT**

Pin on PICtail Plus 30-pin connector (J2)	Pin on ATECC508A	Function
6	6	ATECC508A SCL
8	5	ATECC508A SDA

---

---

## Chapter 3. Getting Started

---

---

This chapter demonstrates how the WINC1500 PICtail/PICtail Plus Daughter Board can be plugged into the PIC18 Explorer, Explorer 16, and Explorer 16/32 Development Boards.

The WINC1500 Daughter Board can be plugged into multiple Microchip Technology demonstration and development boards. This allows the developer to choose the microcontroller that best suits the customer's development environment.

The PICtail connector (J5) can be plugged into 8-bit demonstration and development board, such as PIC 18 Explorer Board (DM183032). The PICtail Plus card edge connector (J2) can be plugged into Explorer 16 Development Board (DM240001).

This chapter includes the following topics:

**3.1 “Plugging into PIC18 Explorer Board”**

**3.2 “Plugging into Explorer 16 Development Board”**

**3.3 “Plugging into Explorer 16/32 Development Board”**

### 3.1 PLUGGING INTO PIC18 EXPLORER BOARD

The WINC1500 PICtail/PICtail Plus Daughter Board can be plugged into the PICtail connector (J3) of the PIC18 Explorer Board. Ensure that the pin1 is aligned to RE2 as shown in [Figure 3-1](#).

CAUTION
Ensure that the PIC18F87J11 PIM is plugged into the PIC18 Explorer Board. This sets the system voltage $V_{DD}$ to 3.3V, which is required by the WINC1500 PICtail/PICtail Plus Daughter Board.

FIGURE 3-1: WINC1500 DAUGHTER BOARD PLUGGED INTO PIC18 EXPLORER BOARD

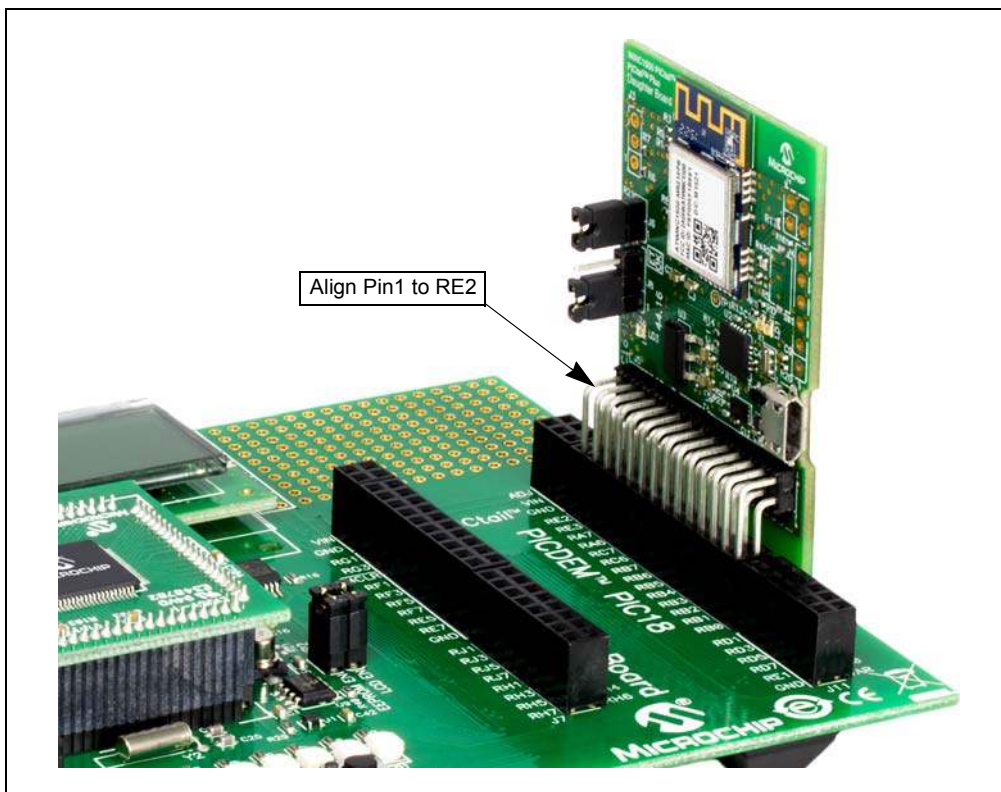

## 3.2 PLUGGING INTO EXPLORER 16 DEVELOPMENT BOARD

The WINC1500 PICtail/PICtail Plus Daughter Board can be plugged into the Explorer 16 Development Board, as illustrated in [Figure 3-2](#).

The WINC1500 daughter board with 30-pin card edge connector can be plugged into the top (pin 1-30) of the PICtail Plus connector. This will connect the WINC1500 module to the SPI Port 1 on the PIC microcontroller that is plugged into the PIM socket. If the daughter board is plugged into the mid-section of the PICtail Plus connector, this will connect to SPI Port 2 on the PIC microcontroller.

**FIGURE 3-2: WINC1500 DAUGHTER BOARD PLUGGED INTO EXPLORER 16 DEVELOPMENT BOARD**



### 3.3 PLUGGING INTO EXPLORER 16/32 DEVELOPMENT BOARD

The WINC1500 PICtail/PICtail Plus Daughter Board can be plugged into the Explorer 16/32 Development Board, as illustrated in [Figure 3-3](#). This setup requires the PICtail Plus expansion board to be plugged into the Explorer 16/32 development board.

**FIGURE 3-3: WINC1500 DAUGHTER BOARD PLUGGED INTO EXPLORER 16/32 DEVELOPMENT BOARD**



# WINC1500 PICtail™/PICtail Plus Daughter Board User's Guide

---

---

NOTES:

## Appendix A. Schematics

### A.1 REFERENCE SCHEMATICS

FIGURE A-1: WINC1500 PICTAIL/PICTAIL PLUS SCHEMATICS

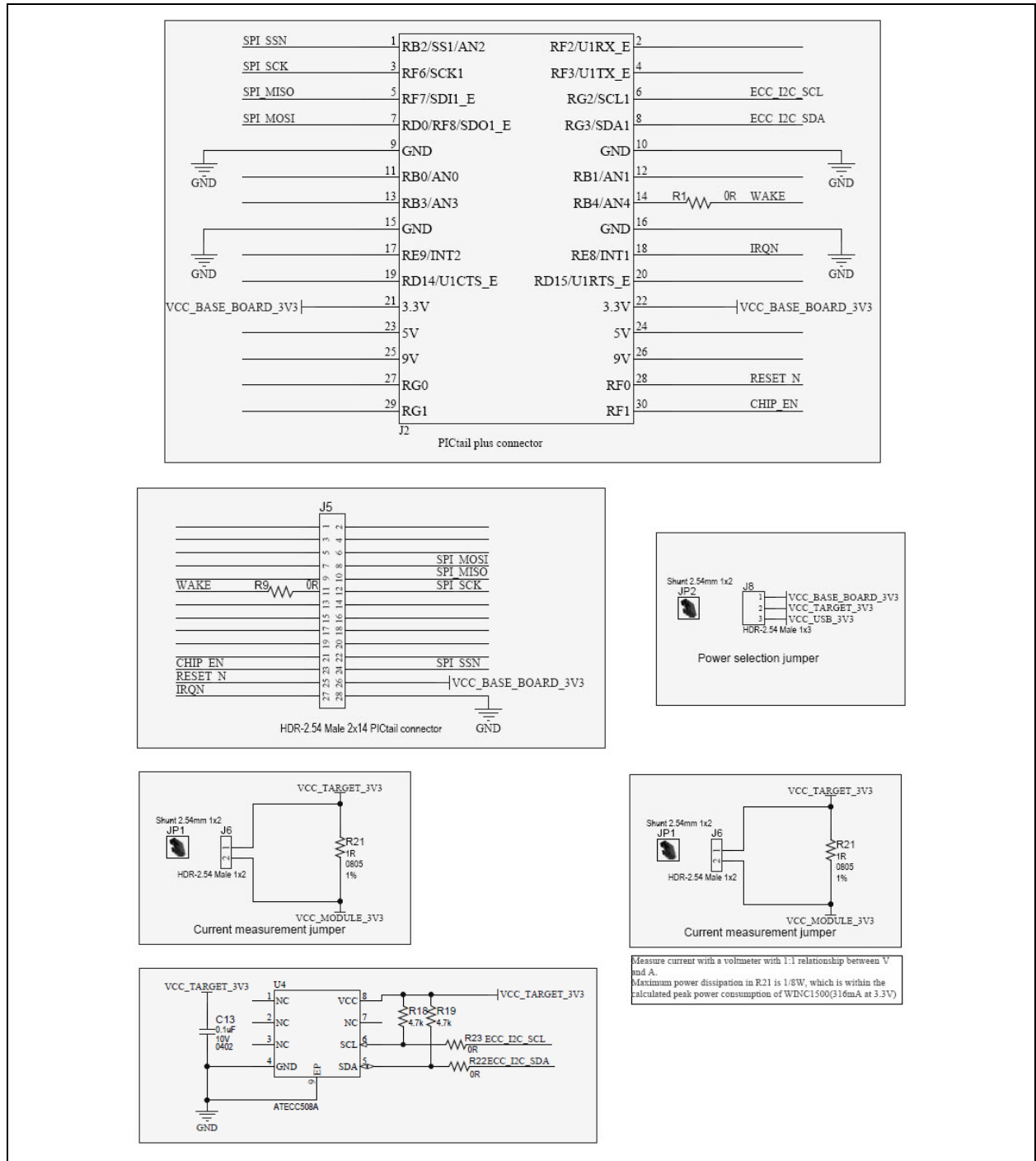
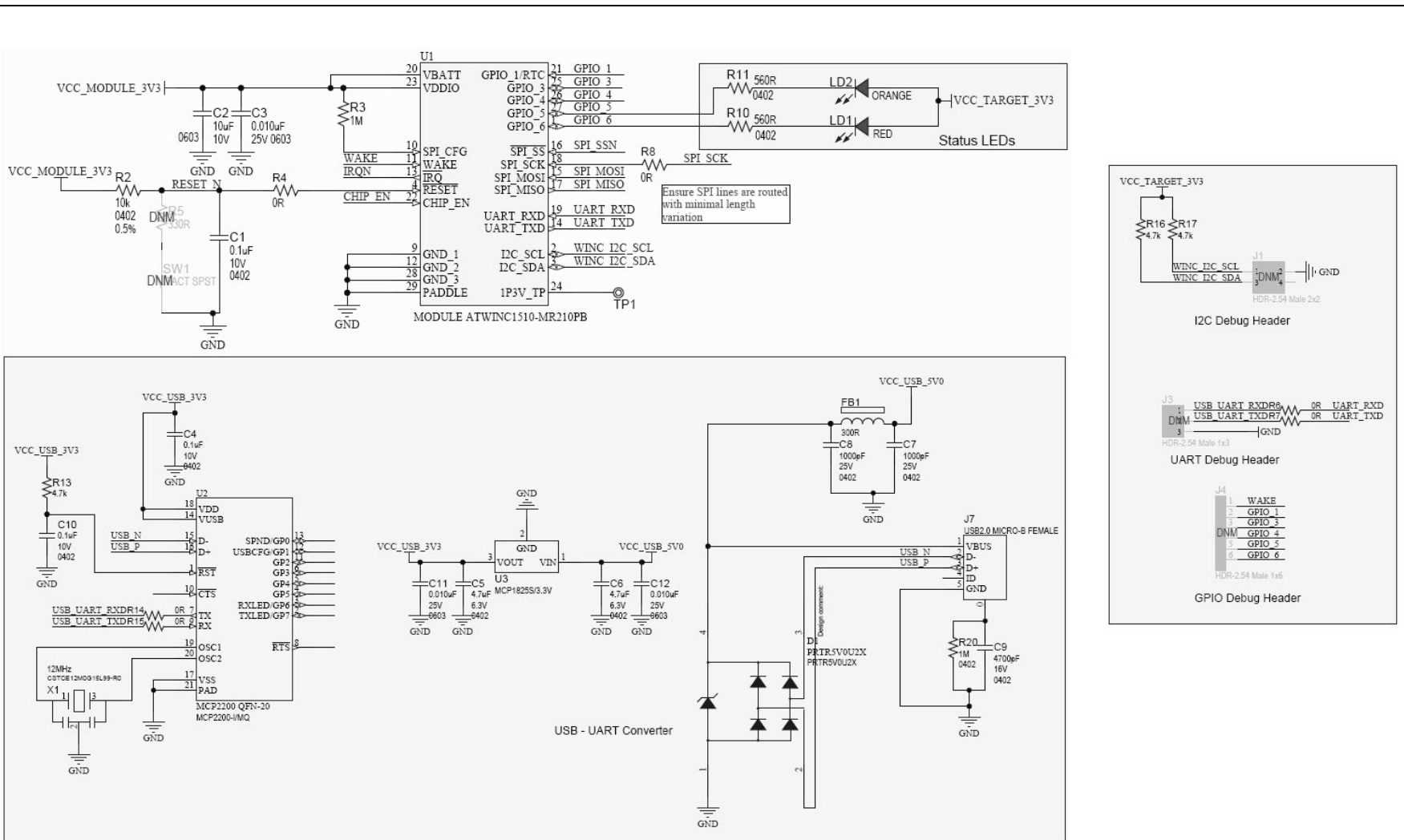

FIGURE A-2: WINC1500 PICTAIL/PICTAIL PLUS MODULE SCHEMATICS



**Note:** Power to the WINC1500 PICTail/PICTail Plus Daughter Board must be in the range of 3.0V to 3.6V. Ensure that the daughter board is plugged into a development/demonstration board that meets this voltage requirement; otherwise, damage to the WINC1500 may occur. Only 3.3V I/O compatible MCU must be interfaced with this board, as all the module I/O lines operate at 3.3V.



**FIGURE A-3: WINC1500 PICTAIL/PICTAIL PLUS DAUGHTER BOARD SILK SCREEN (TOP VIEW)**

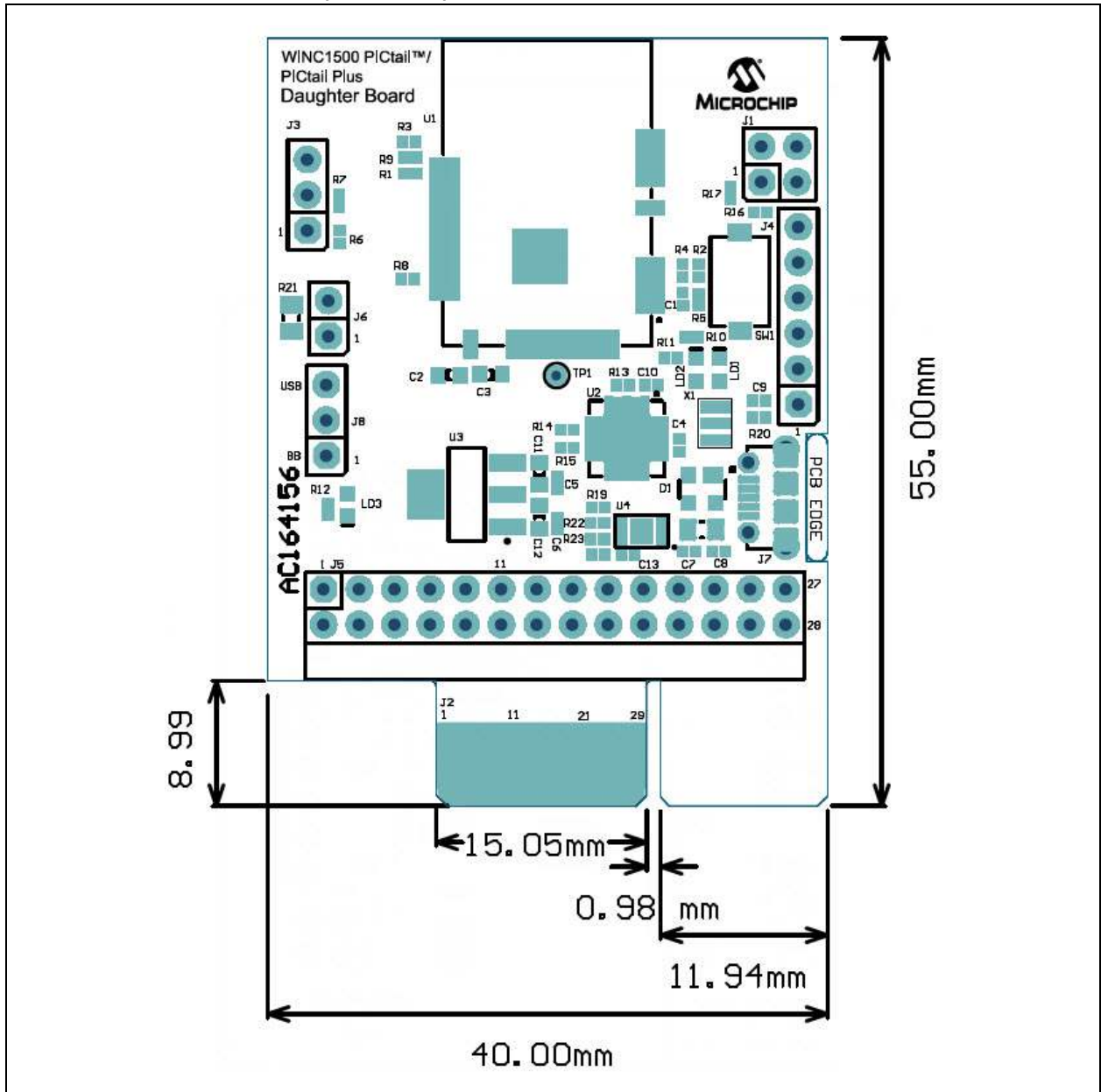

# WINC1500 PICtail™/PICtail Plus Daughter Board User's Guide

---

---

NOTES:



# WINC1500 PICTAIL™/PICTAIL PLUS DAUGHTER BOARD USER'S GUIDE

## Appendix B. Bill of Materials

### B.1 WINC1500 PICTAIL/PICTAIL PLUS DAUGHTER BOARD BILL OF MATERIALS

**TABLE B-1: BILL OF MATERIALS**

Reference	Description	Manufacturer	Part Number	Quantity
C1, C4, C10, C13	CAP CER 0.1 µF 10V 10% X5R SMD 0402	Kemet	C0402C104K8PACTU	4
C2	CAP CER 10 µF 10V 20% X5R SMD 0603	Panasonic	ECJ-1VB1A106M	1
C3, C11, C12	CAP CER 0.010 µF 25V 10% X7R SMD 0603	Yageo	CC0603KRX7R8BB103	3
C5, C6	CAP CER 4.7 µF 6.3V 20% X5R SMD 0402	Murata Electronics North America	GRM155R60J475ME47D	2
C7, C8	CAP CER 1000 pF 25V 5% C0G SMD 0402	TDK Corporation	C1005C0G1E102J	2
C9	CAP CER 4700 pF 16V 10% X7R SMD 0402	Murata Electronics North America	GRM155R71C472KA01D	1
D1	DIO TVS PRTR5V0U2X 5.5V SMD SOT-143	NXP Semiconductors	PRTR5V0U2X,215	1
FB1	FERRITE 300R@100 MHz 2A SMD 0805	Laird-Signal Integrity Products	MI0805L301R-10	1
J5	CON HDR-2.54 Male 2x14 Gold 5.84MH TH R/A	Sullins Connector Solutions	PBC14DBDN	1
J6	CON HDR-2.54 Male 1x2 Gold 5.84MH TH VERT	FCI	77311-118-02LF	1
J7	CON USB2.0 MICRO-B FEMALE TH/SMD R/A	FCI	10118194-0001LF	1
J8	CON HDR-2.54 Male 1x3 Tin 5.84MH TH VERT	Samtec	TSW-103-07-T-S	1
JP1, JP2	MECH HW JUMPER 2.54 mm 1x2	3M	969102-0000-DA	2
LD1	DIO LED RED 2V 30 mA 2mcd Clear SMD 0603	Lite-On	LTST-C190EKT	1
LD2	DIO LED ORANGE 2V 30 mA 90mcd Clear SMD 0603	Lite-On	LTST-C190KFKT	1
LD3	DIO LED GREEN 2.1V 30 mA 6mcd Clear SMD 0603	Lite-On	LTST-C190GKT	1
R1, R4, R6, R7, R8, R9, R14, R15, R22, R23	RES TKF 0R SMD 0402	Panasonic	ERJ-2GE0R00X	8

# WINC1500 PICtail™/PICtail Plus Daughter Board User's Guide

**TABLE B-1: BILL OF MATERIALS (CONTINUED)**

Reference	Description	Manufacturer	Part Number	Quantity
R2	RES TF 10k 0.5% 1/16W SMD 0402	SUSUMU	RR0510P-103-D	1
R3, R20	RES TKF 1M 5% 1/16W SMD 0402	Yageo	RC0402JR-071ML	2
R10, R11, R12	RES TKF 560R 5% 1/10W SMD 0402	Panasonic	ERJ-2GEJ561X	3
R13, R16, R17, R18, R19	RES TKF 4.7K 1% 1/10W 0402	KOA Speer	RK73H1ETTP4701F	5
R21	RES TKF 1R 1% 1/8W SMD 0805	Panasonic	ERJ-6RQF1R0V	1
U4	IC INTERFACE ATECC508A UDFN-8	Atmel	ATECC508A-MAHDA-T	1
X1	RESONATOR 12 MHz 0.1% SMD CSTCE-G	Murata Electronics North America	CSTCE12M0G15L99-R0	1
U1	MCHP RF WI-FI 802.11b/g/n ATWINC1510-MR210PB MODULE-28	Microchip Technology Inc.	ATWINC1510-MR210PB	1
U2	MCHP INTERFACE USB UART MCP2200-I/MQ QFN-20	Microchip Technology Inc.	MCP2200-I/MQ	1
U3	MCHP ANALOG LDO 3.3V MCP1825ST-3302E/DB SOT-223-3	Microchip Technology Inc.	MCP1825ST-3302E/DB	1
R5	RES TKF 330R 5% 1/10W SMD 0402	Panasonic Electronic Components	ERJ-2GEJ331X	1
SW1	SWITCH TACT SPST 32V 50mA KSR231GLFS SMD	C&K Components	KSR231GLFS	1

---

---

**NOTES:**



# MICROCHIP

## Worldwide Sales and Service

### AMERICAS

**Corporate Office**  
2355 West Chandler Blvd.  
Chandler, AZ 85224-6199  
Tel: 480-792-7200  
Fax: 480-792-7277  
Technical Support:  
<http://www.microchip.com/support>  
Web Address:  
[www.microchip.com](http://www.microchip.com)

**Atlanta**  
Duluth, GA  
Tel: 678-957-9614  
Fax: 678-957-1455

**Austin, TX**  
Tel: 512-257-3370

**Boston**  
Westborough, MA  
Tel: 774-760-0087  
Fax: 774-760-0088

**Chicago**  
Itasca, IL  
Tel: 630-285-0071  
Fax: 630-285-0075

**Dallas**  
Addison, TX  
Tel: 972-818-7423  
Fax: 972-818-2924

**Detroit**  
Novi, MI  
Tel: 248-848-4000

**Houston, TX**  
Tel: 281-894-5983

**Indianapolis**  
Noblesville, IN  
Tel: 317-773-8323  
Fax: 317-773-5453  
Tel: 317-536-2380

**Los Angeles**  
Mission Viejo, CA  
Tel: 949-462-9523  
Fax: 949-462-9608  
Tel: 951-273-7800

**Raleigh, NC**  
Tel: 919-844-7510

**New York, NY**  
Tel: 631-435-6000

**San Jose, CA**  
Tel: 408-735-9110  
Tel: 408-436-4270

**Canada - Toronto**  
Tel: 905-695-1980  
Fax: 905-695-2078

### ASIA/PACIFIC

**Asia Pacific Office**  
Suites 3707-14, 37th Floor  
Tower 6, The Gateway  
Harbour City, Kowloon

**Hong Kong**  
Tel: 852-2943-5100  
Fax: 852-2401-3431

**Australia - Sydney**  
Tel: 61-2-9868-6733  
Fax: 61-2-9868-6755

**China - Beijing**  
Tel: 86-10-8569-7000  
Fax: 86-10-8528-2104

**China - Chengdu**  
Tel: 86-28-8665-5511  
Fax: 86-28-8665-7889

**China - Chongqing**  
Tel: 86-23-8980-9588  
Fax: 86-23-8980-9500

**China - Dongguan**  
Tel: 86-769-8702-9880

**China - Guangzhou**  
Tel: 86-20-8755-8029

**China - Hangzhou**  
Tel: 86-571-8792-8115  
Fax: 86-571-8792-8116

**China - Hong Kong SAR**  
Tel: 852-2943-5100  
Fax: 852-2401-3431

**China - Nanjing**  
Tel: 86-25-8473-2460  
Fax: 86-25-8473-2470

**China - Qingdao**  
Tel: 86-532-8502-7355  
Fax: 86-532-8502-7205

**China - Shanghai**  
Tel: 86-21-3326-8000  
Fax: 86-21-3326-8021

**China - Shenyang**  
Tel: 86-24-2334-2829  
Fax: 86-24-2334-2393

**China - Shenzhen**  
Tel: 86-755-8864-2200  
Fax: 86-755-8203-1760

**China - Wuhan**  
Tel: 86-27-5980-5300  
Fax: 86-27-5980-5118

**China - Xian**  
Tel: 86-29-8833-7252  
Fax: 86-29-8833-7256

### ASIA/PACIFIC

**China - Xiamen**  
Tel: 86-592-2388138  
Fax: 86-592-2388130

**China - Zhuhai**  
Tel: 86-756-3210040  
Fax: 86-756-3210049

**India - Bangalore**  
Tel: 91-80-3090-4444  
Fax: 91-80-3090-4123

**India - New Delhi**  
Tel: 91-11-4160-8631  
Fax: 91-11-4160-8632

**India - Pune**  
Tel: 91-20-3019-1500

**Japan - Osaka**  
Tel: 81-6-6152-7160  
Fax: 81-6-6152-9310

**Japan - Tokyo**  
Tel: 81-3-6880-3770  
Fax: 81-3-6880-3771

**Korea - Daegu**  
Tel: 82-53-744-4301  
Fax: 82-53-744-4302

**Korea - Seoul**  
Tel: 82-2-554-7200  
Fax: 82-2-558-5932 or  
82-2-558-5934

**Malaysia - Kuala Lumpur**  
Tel: 60-3-6201-9857  
Fax: 60-3-6201-9859

**Malaysia - Penang**  
Tel: 60-4-227-8870  
Fax: 60-4-227-4068

**Philippines - Manila**  
Tel: 63-2-634-9065  
Fax: 63-2-634-9069

**Singapore**  
Tel: 65-6334-8870  
Fax: 65-6334-8850

**Taiwan - Hsin Chu**  
Tel: 886-3-5778-366  
Fax: 886-3-5770-955

**Taiwan - Kaohsiung**  
Tel: 886-7-213-7830

**Taiwan - Taipei**  
Tel: 886-2-2508-8600  
Fax: 886-2-2508-0102

**Thailand - Bangkok**  
Tel: 66-2-694-1351  
Fax: 66-2-694-1350

### EUROPE

**Austria - Wels**  
Tel: 43-7242-2244-39  
Fax: 43-7242-2244-393

**Denmark - Copenhagen**  
Tel: 45-4450-2828  
Fax: 45-4485-2829

**Finland - Espoo**  
Tel: 358-9-4520-820

**France - Paris**  
Tel: 33-1-69-53-63-20  
Fax: 33-1-69-30-90-79

**France - Saint Cloud**  
Tel: 33-1-30-60-70-00

**Germany - Garching**  
Tel: 49-8931-9700

**Germany - Haan**  
Tel: 49-2129-3766400

**Germany - Heilbronn**  
Tel: 49-7131-67-3636

**Germany - Karlsruhe**  
Tel: 49-721-625370

**Germany - Munich**  
Tel: 49-89-627-144-0  
Fax: 49-89-627-144-44

**Germany - Rosenheim**  
Tel: 49-8031-354-560

**Israel - Ra'anana**  
Tel: 972-9-744-7705

**Italy - Milan**  
Tel: 39-0331-742611  
Fax: 39-0331-466781

**Italy - Padova**  
Tel: 39-049-7625286

**Netherlands - Druen**  
Tel: 31-416-690399  
Fax: 31-416-690340

**Norway - Trondheim**  
Tel: 47-7289-7561

**Poland - Warsaw**  
Tel: 48-22-3325737

**Romania - Bucharest**  
Tel: 40-21-407-87-50

**Spain - Madrid**  
Tel: 34-91-708-08-90  
Fax: 34-91-708-08-91

**Sweden - Gothenberg**  
Tel: 46-31-704-60-40

**Sweden - Stockholm**  
Tel: 46-8-5090-4654

**UK - Wokingham**  
Tel: 44-118-921-5800  
Fax: 44-118-921-5820