

# $\mu$ C/OS-III™

*The Real-Time Kernel*

# $\mu$ C/OS-III

**User's Manual**

**Micrium**

This book puts the spotlight on how a real-time kernel works, using Micrium's  $\mu$ C/OS-III as a reference.

This book is written for serious embedded systems programmers, consultants, hobbyists, and students interested in understanding the inner workings of a real-time kernel.  $\mu$ C/OS-III is not just a great learning platform, but also a full commercial-grade software package, ready to be part of a wide range of products.

$\mu$ C/OS-III is a highly portable, ROMable, scalable, preemptive real-time, multitasking kernel designed specifically to address the demanding requirements of today's embedded systems.  $\mu$ C/OS-III is the successor to the highly popular  $\mu$ C/OS-II real-time kernel but can use most of  $\mu$ C/OS-II's ports with minor modifications. Some of the features of  $\mu$ C/OS-III are:

- Preemptive multitasking with round-robin scheduling of tasks at the same priority
- Supports and unlimited number of tasks and other kernel objects
- Rich set of services: semaphores, mutual exclusion semaphores with full priority inheritance, event flags, message queues, timers, fixed-size memory block management, and more.
- Built-in performance measurements

**Micrium**  
 **Press**

### About Micrium

Micrium provides the highest quality embedded software components by way of cleanest source code, unsurpassed documentation, and customer support. Starting with Micrium's flagship product,  $\mu$ C/OS through its complete line of software, Micrium shortens time to market throughout all product development cycles and builds products that address today's increased design complexity.

[www.micrium.com](http://www.micrium.com)

ISBN 978-0-9823375-9-2



9 780982 337592

# **μC/OS-III™** *The Real-Time Kernel*

## **User's Manual**

**Micrium**  
 **Press**

Weston, FL 33326

Micrium Press  
1290 Weston Road, Suite 306  
Weston, FL 33326  
USA  
[www.micrium.com](http://www.micrium.com)

Designations used by companies to distinguish their products are often claimed as trademarks. In all instances where Micrium Press is aware of a trademark claim, the product name appears in initial capital letters, in all capital letters, or in accordance with the vendor's capitalization preference. Readers should contact the appropriate companies for more complete information on trademarks and trademark registrations. All trademarks and registered trademarks in this book are the property of their respective holders.

Copyright © 2010 by Micrium Press except where noted otherwise. Published by Micrium Press. All rights reserved. Printed in the United States of America. No part of this publication may be reproduced or distributed in any form or by any means, or stored in a database or retrieval system, without the prior written permission of the publisher; with the exception that the program listings may be entered, stored, and executed in a computer system, but they may not be reproduced for publication.

The programs and code examples in this book are presented for instructional value. The programs and examples have been carefully tested, but are not guaranteed to any particular purpose. The publisher does not offer any warranties and does not guarantee the accuracy, adequacy, or completeness of any information herein and is not responsible for any errors and omissions. The publisher assumes no liability for damages resulting from the use of the information in this book or for any infringement of the intellectual property rights of third parties that would result from the use of this information.

For bulk orders, please contact Micrium Press at: +1 954 217 2036

ISBN: 978-0-9823375-9-2  
600-uCOS-III-Users-Manual-002

**Micrium**  
 **Press**

# Table of Contents

|                  |  |    |
|------------------|--|----|
|                  | Preface .....  | 13 |
| <b>Chapter 1</b> | Introduction .....   | 15 |
| <b>1-1</b>       | Foreground/Background Systems .....                                    | 16 |
| <b>1-2</b>       | Real-Time Kernels .....  | 17 |
| <b>1-3</b>       | RTOS (Real-Time Operating System) .....                                | 19 |
| <b>1-4</b>       | $\mu$ C/OS-III .....   | 19 |
| <b>1-5</b>       | $\mu$ C/OS, $\mu$ C/OS-II and $\mu$ C/OS-III Features Comparison ..... | 24 |
| <b>1-6</b>       | How the Book is Organized .....  | 26 |
| <b>1-7</b>       | $\mu$ C/Probe .....  | 26 |
| <b>1-8</b>       | Conventions .....  | 27 |
| <b>1-9</b>       | Chapter Contents .....   | 28 |
| <b>1-10</b>      | Licensing .....  | 32 |
| <b>1-11</b>      | Contacting Micrium .....   | 32 |
| <b>Chapter 2</b> | Directories and Files .....  | 33 |
| <b>2-1</b>       | Application Code .....   | 36 |
| <b>2-2</b>       | CPU .....  | 37 |
| <b>2-3</b>       | Board Support Package (BSP) .....                                      | 38 |
| <b>2-4</b>       | $\mu$ C/OS-III, CPU Independent Source Code .....                      | 39 |
| <b>2-5</b>       | $\mu$ C/OS-III, CPU Specific Source Code .....                         | 43 |
| <b>2-6</b>       | $\mu$ C/CPU, CPU Specific Source Code .....                            | 44 |
| <b>2-7</b>       | $\mu$ C/LIB, Portable Library Functions .....                          | 46 |
| <b>2-8</b>       | Summary .....  | 47 |
| <b>Chapter 3</b> | Getting Started with $\mu$ C/OS-III .....                              | 51 |
| <b>3-1</b>       | Single Task Application .....  | 52 |
| <b>3-2</b>       | Multiple Tasks Application with Kernel Objects .....                   | 60 |

|                  |  |     |
|------------------|--|-----|
| <b>Chapter 4</b> | Critical Sections .....                                | 69  |
| <b>4-1</b>       | Disabling Interrupts .....                             | 70  |
| <b>4-1-1</b>     | Measuring Interrupt Disable Time .....                 | 70  |
| <b>4-2</b>       | Locking the Scheduler .....                            | 71  |
| <b>4-2-1</b>     | Measuring Scheduler Lock Time .....                    | 72  |
| <b>4-3</b>       | µC/OS-III Features with Longer Critical Sections ..... | 73  |
| <b>4-4</b>       | Summary .....  | 74  |
| <br>             |  |     |
| <b>Chapter 5</b> | Task Management .....                                  | 75  |
| <b>5-1</b>       | Assigning Task Priorities .....                        | 84  |
| <b>5-2</b>       | Determining the Size of a Stack .....                  | 86  |
| <b>5-3</b>       | Detecting Task Stack Overflows .....                   | 87  |
| <b>5-4</b>       | Task Management Services .....                         | 91  |
| <b>5-5</b>       | Task Management Internals .....                        | 92  |
| <b>5-5-1</b>     | Task States .....                                      | 92  |
| <b>5-5-2</b>     | Task Control Blocks (TCBs) .....                       | 97  |
| <b>5-6</b>       | Internal Tasks .....                                   | 106 |
| <b>5-6-1</b>     | The Idle Task (OS_IdleTask()) .....                    | 107 |
| <b>5-6-2</b>     | The Tick Task (OS_TickTask()) .....                    | 109 |
| <b>5-6-3</b>     | The Statistic Task (OS_StatTask()) .....               | 116 |
| <b>5-6-4</b>     | The Timer Task (OS_TmrTask()) .....                    | 119 |
| <b>5-6-5</b>     | The ISR Handler Task (OS_IntQTask()) .....             | 120 |
| <b>5-7</b>       | Summary .....  | 121 |
| <br>             |  |     |
| <b>Chapter 6</b> | The Ready List .....                                   | 123 |
| <b>6-1</b>       | Priority Levels .....                                  | 124 |
| <b>6-2</b>       | The Ready List .....                                   | 128 |
| <b>6-3</b>       | Adding Tasks to the Ready List .....                   | 131 |
| <b>6-4</b>       | Summary .....  | 132 |
| <br>             |  |     |
| <b>Chapter 7</b> | Scheduling .....                                       | 133 |
| <b>7-1</b>       | Preemptive Scheduling .....                            | 134 |
| <b>7-2</b>       | Scheduling Points .....                                | 136 |
| <b>7-3</b>       | Round-Robin Scheduling .....                           | 138 |
| <b>7-4</b>       | Scheduling Internals .....                             | 141 |
| <b>7-4-1</b>     | OSSched() .....  | 142 |
| <b>7-4-2</b>     | OSIntExit() .....                                      | 143 |

---

|                   |  |     |
|-------------------|--|-----|
| <b>7-4-3</b>      | OS_SchedRoundRobin() .....                                   | 144 |
| <b>7-5</b>        | Summary .....  | 146 |
| <b>Chapter 8</b>  | Context Switching .....                                      | 147 |
| <b>8-1</b>        | OSCtxSw() .....  | 150 |
| <b>8-2</b>        | OSIntCtxSw() .....   | 153 |
| <b>8-3</b>        | Summary .....  | 155 |
| <b>Chapter 9</b>  | Interrupt Management .....                                   | 157 |
| <b>9-1</b>        | Handling CPU Interrupts .....                                | 158 |
| <b>9-2</b>        | Typical $\mu$ C/OS-III Interrupt Service Routine (ISR) ..... | 159 |
| <b>9-3</b>        | Short Interrupt Service Routine (ISR) .....                  | 162 |
| <b>9-4</b>        | All Interrupts Vector to a Common Location .....             | 163 |
| <b>9-5</b>        | Every Interrupt Vectors to a Unique Location .....           | 165 |
| <b>9-6</b>        | Direct and Deferred Post Methods .....                       | 166 |
| <b>9-6-1</b>      | Direct Post Method .....                                     | 166 |
| <b>9-6-2</b>      | Deferred Post Method .....                                   | 169 |
| <b>9-7</b>        | Direct vs. Deferred Post Method .....                        | 172 |
| <b>9-8</b>        | The Clock Tick (or System Tick) .....                        | 173 |
| <b>9-9</b>        | Summary .....  | 175 |
| <b>Chapter 10</b> | Pend Lists (or Wait Lists) .....                             | 177 |
| <b>10-1</b>       | Summary .....  | 182 |
| <b>Chapter 11</b> | Time Management .....  | 183 |
| <b>11-1</b>       | OSTimeDly() .....  | 184 |
| <b>11-2</b>       | OSTimeDlyHMSM() .....  | 189 |
| <b>11-3</b>       | OSTimeDlyResume() .....                                      | 191 |
| <b>11-4</b>       | OSTimeSet() and OSTimeGet() .....                            | 192 |
| <b>11-5</b>       | OSTimeTick() .....   | 192 |
| <b>11-6</b>       | Summary .....  | 192 |
| <b>Chapter 12</b> | Timer Management .....                                       | 193 |
| <b>12-1</b>       | One-Shot Timers .....  | 195 |
| <b>12-2</b>       | Periodic (no initial delay) .....                            | 196 |
| <b>12-3</b>       | Periodic (with initial delay) .....                          | 196 |

|                   |  |     |
|-------------------|--|-----|
| <b>12-4</b>       | Timer Management Internals .....                     | 197 |
| <b>12-4-1</b>     | Timer Management Internals - Timers States .....     | 197 |
| <b>12-4-2</b>     | Timer Management Internals - OS_TMR .....            | 198 |
| <b>12-4-3</b>     | Timer Management Internals - Timer Task .....        | 200 |
| <b>12-4-4</b>     | Timer Management Internals - Timer List .....        | 203 |
| <b>12-5</b>       | Summary .....  | 208 |
| <br>              |  |     |
| <b>Chapter 13</b> | Resource Management .....                            | 209 |
| <b>13-1</b>       | Disable/Enable Interrupts .....                      | 212 |
| <b>13-2</b>       | Lock/Unlock .....                                    | 214 |
| <b>13-3</b>       | Semaphores .....                                     | 215 |
| <b>13-3-1</b>     | Binary Semaphores .....                              | 217 |
| <b>13-3-2</b>     | Counting Semaphores .....                            | 224 |
| <b>13-3-3</b>     | Notes on Semaphores .....                            | 226 |
| <b>13-3-4</b>     | Semaphore Internals (for resource sharing) .....     | 227 |
| <b>13-3-5</b>     | Priority Inversions .....                            | 232 |
| <b>13-4</b>       | Mutual Exclusion Semaphores (Mutex) .....            | 234 |
| <b>13-4-1</b>     | Mutual Exclusion Semaphore Internals .....           | 239 |
| <b>13-5</b>       | Should You Use a Semaphore Instead of a Mutex? ..... | 245 |
| <b>13-6</b>       | Deadlocks (or Deadly Embrace) .....                  | 245 |
| <b>13-7</b>       | Summary .....  | 250 |
| <br>              |  |     |
| <b>Chapter 14</b> | Synchronization .....                                | 251 |
| <b>14-1</b>       | Semaphores .....                                     | 252 |
| <b>14-1-1</b>     | Unilateral Rendezvous .....                          | 254 |
| <b>14-1-2</b>     | Credit Tracking .....                                | 257 |
| <b>14-1-3</b>     | Multiple Tasks Waiting on a Semaphore .....          | 259 |
| <b>14-1-4</b>     | Semaphore Internals (for synchronization) .....      | 260 |
| <b>14-2</b>       | Task Semaphore .....                                 | 267 |
| <b>14-2-1</b>     | Pending (i.e., Waiting) on a Task Semaphore .....    | 268 |
| <b>14-2-2</b>     | Posting (i.e., Signaling) a Task Semaphore .....     | 269 |
| <b>14-2-3</b>     | Bilateral Rendezvous .....                           | 271 |
| <b>14-3</b>       | Event Flags .....                                    | 273 |
| <b>14-3-1</b>     | Using Event Flags .....                              | 275 |
| <b>14-3-2</b>     | Event Flags Internals .....                          | 279 |
| <b>14-4</b>       | Synchronizing Multiple Tasks .....                   | 286 |
| <b>14-5</b>       | Summary .....  | 288 |



---

|                   |   |     |
|-------------------|---|-----|
| <b>Chapter 15</b> | Message Passing .....                         | 289 |
| <b>15-1</b>       | Messages .....                                | 290 |
| <b>15-2</b>       | Message Queues .....                          | 290 |
| <b>15-3</b>       | Task Message Queue .....                      | 292 |
| <b>15-4</b>       | Bilateral Rendezvous .....                    | 293 |
| <b>15-5</b>       | Flow Control .....                            | 294 |
| <b>15-6</b>       | Keeping the Data in Scope .....               | 296 |
| <b>15-7</b>       | Using Message Queues .....                    | 299 |
| <b>15-8</b>       | Clients and Servers .....                     | 307 |
| <b>15-9</b>       | Message Queues Internals .....                | 308 |
| <b>15-10</b>      | Summary .....                                 | 311 |
| <br>              |   |     |
| <b>Chapter 16</b> | Pending On Multiple Objects .....             | 313 |
| <b>16-1</b>       | Summary .....                                 | 321 |
| <br>              |   |     |
| <b>Chapter 17</b> | Memory Management .....                       | 323 |
| <b>17-1</b>       | Creating a Memory Partition .....             | 324 |
| <b>17-2</b>       | Getting a Memory Block from a Partition ..... | 328 |
| <b>17-3</b>       | Returning a Memory Block to a Partition ..... | 329 |
| <b>17-4</b>       | Using Memory Partitions .....                 | 330 |
| <b>17-5</b>       | Summary .....                                 | 333 |
| <br>              |   |     |
| <b>Chapter 18</b> | Porting $\mu$ C/OS-III .....                  | 335 |
| <b>18-1</b>       | $\mu$ C/CPU .....                             | 338 |
| <b>18-2</b>       | $\mu$ C/OS-III Port .....                     | 341 |
| <b>18-3</b>       | Board Support Package (BSP) .....             | 343 |
| <b>18-4</b>       | Summary .....                                 | 345 |
| <br>              |   |     |
| <b>Chapter 19</b> | Run-Time Statistics .....                     | 347 |
| <b>19-1</b>       | General Statistics – Run-Time .....           | 348 |
| <b>19-2</b>       | Per-Task Statistics – Run-Time .....          | 352 |
| <b>19-3</b>       | Kernel Object – Run-Time .....                | 355 |
| <b>19-4</b>       | OS_DBG.C – Static .....                       | 358 |
| <b>19-5</b>       | OS_CFG_APP.C – Static .....                   | 371 |
| <b>19-6</b>       | Summary .....                                 | 373 |

|                   |  |            |
|-------------------|--|------------|
| <b>Appendix A</b> | <b>μC/OS-III API Reference Manual</b> .....                    | <b>375</b> |
| <b>A-1</b>        | <b>Task Management</b> .....                                   | <b>376</b> |
| <b>A-2</b>        | <b>Time Management</b> .....                                   | <b>378</b> |
| <b>A-3</b>        | <b>Mutual Exclusion Semaphores – Resource Management</b> ..... | <b>379</b> |
| <b>A-4</b>        | <b>Event Flags – Synchronization</b> .....                     | <b>380</b> |
| <b>A-5</b>        | <b>Semaphores – Synchronization</b> .....                      | <b>381</b> |
| <b>A-6</b>        | <b>Task Semaphores – Synchronization</b> .....                 | <b>382</b> |
| <b>A-7</b>        | <b>Message Queues – Message Passing</b> .....                  | <b>383</b> |
| <b>A-8</b>        | <b>Task Message Queues – Message Passing</b> .....             | <b>384</b> |
| <b>A-9</b>        | <b>Pending on Multiple Objects</b> .....                       | <b>385</b> |
| <b>A-10</b>       | <b>Timers</b> .....  | <b>386</b> |
| <b>A-11</b>       | <b>Fixed-Size Memory Partitions – Memory Management</b> .....  | <b>387</b> |
|                   | OSCtxSw() .....  | 388        |
|                   | OSFlagCreate() .....   | 390        |
|                   | OSFlagDel() .....  | 392        |
|                   | OSFlagPend() .....   | 394        |
|                   | OSFlagPendAbort() .....  | 398        |
|                   | OSFlagPendGetFlagsRdy() .....                                  | 401        |
|                   | OSFlagPost() .....   | 403        |
|                   | OSIdleTaskHook() .....   | 405        |
|                   | OSInit() .....   | 407        |
|                   | OSInitHook() .....   | 409        |
|                   | OSIntCtxSw() .....   | 410        |
|                   | OSIntEnter() .....   | 412        |
|                   | OSIntExit() .....  | 413        |
|                   | OSMemCreate() .....  | 414        |
|                   | OSMemGet() .....   | 417        |
|                   | OSMemPut() .....   | 419        |
|                   | OSMutexCreate() .....  | 421        |
|                   | OSMutexDel() .....   | 423        |
|                   | OSMutexPend() .....  | 425        |
|                   | OSMutexPendAbort() .....                                       | 428        |
|                   | OSMutexPost() .....  | 430        |
|                   | OSPendMulti() .....  | 432        |
|                   | OSQCreate() .....  | 436        |
|                   | OSQDel() .....   | 438        |
|                   | OSQFlush() .....   | 440        |
|                   | OSQPend() .....  | 442        |

---

|                          |     |
|--------------------------|-----|
| OSQPendAbort()           | 446 |
| OSQPost()                | 448 |
| OSSafetyCriticalStart()  | 451 |
| OSSched()                | 452 |
| OSSchedLock()            | 454 |
| OSSchedRoundRobinCfg()   | 456 |
| OSSchedRoundRobinYield() | 458 |
| OSSchedUnlock()          | 460 |
| OSSemCreate()            | 462 |
| OSSemDel()               | 464 |
| OSSemPend()              | 467 |
| OSSemPendAbort()         | 470 |
| OSSemPost()              | 472 |
| OSSemSet()               | 475 |
| OSStart()                | 477 |
| OSStartHighRdy()         | 479 |
| OSStatReset()            | 481 |
| OSStatTaskCPUUsageInit() | 482 |
| OSStatTaskHook()         | 483 |
| OSTaskChangePrio()       | 485 |
| OSTaskCreate()           | 487 |
| OSTaskCreateHook()       | 498 |
| OSTaskDel()              | 500 |
| OSTaskDelHook()          | 502 |
| OSTaskQPend()            | 504 |
| OSTaskQPendAbort()       | 507 |
| OSTaskQPost()            | 509 |
| OSTaskRegGet()           | 512 |
| OSTaskRegSet()           | 514 |
| OSTaskReturnHook()       | 516 |
| OSTaskResume()           | 518 |
| OSTaskSemPend()          | 520 |
| OSTaskSemPendAbort()     | 523 |
| OSTaskSemPost()          | 525 |
| OSTaskSemSet()           | 527 |
| OSTaskStatHook()         | 529 |
| OSTaskStkChk()           | 531 |
| OSTaskStkInit()          | 534 |

|                   |   |            |
|-------------------|---|------------|
|                   | OSTaskSuspend() .....   | 538        |
|                   | OSTaskSwHook() .....  | 540        |
|                   | OSTaskTimeQuantaSet() .....                                   | 543        |
|                   | OSTickISR() .....   | 545        |
|                   | OSTimeDly().....  | 547        |
|                   | OSTimeDlyHMSM() .....   | 550        |
|                   | OSTimeDlyResume() .....                                       | 553        |
|                   | OSTimeGet() .....   | 555        |
|                   | OSTimeSet() .....   | 556        |
|                   | OSTimeTick() .....  | 558        |
|                   | OSTimeTickHook() .....  | 559        |
|                   | OSTmrCreate() .....   | 561        |
|                   | OSTmrDel() .....  | 567        |
|                   | OSTmrRemainGet() .....  | 569        |
|                   | OSTmrStart().....   | 571        |
|                   | OSTmrStateGet() .....   | 573        |
|                   | OSTmrStop().....  | 575        |
|                   | OSVersion().....  | 577        |
| <b>Appendix B</b> | <b>μC/OS-III Configuration Manual .....</b>                   | <b>579</b> |
| <b>B-1</b>        | <b>μC/OS-III Features (OS_CFG.H) .....</b>                    | <b>583</b> |
| <b>B-2</b>        | <b>Data Types (OS_TYPE.H) .....</b>                           | <b>593</b> |
| <b>B-3</b>        | <b>μC/OS-III Stacks, Pools and other (OS_CFG_APP.H) .....</b> | <b>594</b> |
| <b>Appendix C</b> | <b>Migrating from μC/OS-II to μC/OS-III .....</b>             | <b>599</b> |
| <b>C-1</b>        | <b>Differences in Source File Names and Contents .....</b>    | <b>602</b> |
| <b>C-2</b>        | <b>Convention Changes .....</b>                               | <b>605</b> |
| <b>C-3</b>        | <b>Variable Name Changes .....</b>                            | <b>611</b> |
| <b>C-4</b>        | <b>API Changes .....</b>                                      | <b>612</b> |
| <b>C-4-1</b>      | <b>Event Flags .....</b>                                      | <b>613</b> |
| <b>C-4-2</b>      | <b>Message Mailboxes .....</b>                                | <b>615</b> |
| <b>C-4-3</b>      | <b>Memory Management .....</b>                                | <b>617</b> |
| <b>C-4-4</b>      | <b>Mutual Exclusion Semaphores .....</b>                      | <b>618</b> |
| <b>C-4-5</b>      | <b>Message Queues .....</b>                                   | <b>620</b> |
| <b>C-4-6</b>      | <b>Semaphores .....</b>                                       | <b>622</b> |
| <b>C-4-7</b>      | <b>Task Management .....</b>                                  | <b>624</b> |
| <b>C-4-8</b>      | <b>Time Management .....</b>                                  | <b>628</b> |

---

|                   |  |     |
|-------------------|--|-----|
| <b>C-4-9</b>      | Timer Management .....                   | 629 |
| <b>C-4-10</b>     | Miscellaneous .....                      | 631 |
| <b>C-4-11</b>     | Hooks and Port .....                     | 633 |
| <br>              |  |     |
| <b>Appendix D</b> | MISRA-C:2004 and $\mu$ C/OS-III .....    | 637 |
| <b>D-1</b>        | MISRA-C:2004, Rule 8.5 (Required) .....  | 638 |
| <b>D-2</b>        | MISRA-C:2004, Rule 8.12 (Required) ..... | 638 |
| <b>D-3</b>        | MISRA-C:2004, Rule 14.7 (Required) ..... | 639 |
| <b>D-4</b>        | MISRA-C:2004, Rule 15.2 (Required) ..... | 640 |
| <b>D-5</b>        | MISRA-C:2004, Rule 17.4 (Required) ..... | 641 |
| <br>              |  |     |
| <b>Appendix E</b> | Bibliography .....                       | 643 |
| <br>              |  |     |
| <b>Appendix F</b> | Licensing Policy .....                   | 645 |
| <br>              |  |     |
| Index .....       |  | 647 |

## Table of Contents

---

# Preface

## **WHAT IS $\mu$ C/OS-III?**

$\mu$ C/OS-III (pronounced “Micro C O S Three”) is a scalable, ROMable, preemptive real-time kernel that manages an unlimited number of tasks.  $\mu$ C/OS-III is a third-generation kernel and offers all of the services expected from a modern real-time kernel, such as resource management, synchronization, inter-task communications, and more. However,  $\mu$ C/OS-III offers many unique features not found in other real-time kernels, such as the ability to complete performance measurements at run-time, to directly signal or send messages to tasks, achieve pending on multiple kernel objects, and more.

## **WHY A NEW $\mu$ C/OS VERSION?**

The  $\mu$ C/OS series, first introduced in 1992, has undergone a number of changes over the years based on feedback from thousands of people using and deploying its evolving versions.

$\mu$ C/OS-III is the sum of this feedback and experience. Rarely used  $\mu$ C/OS-II features were eliminated and newer, more efficient features and services, were added. Probably the most common request was to add round robin scheduling, which was not possible for  $\mu$ C/OS-II, but is now a feature of  $\mu$ C/OS-III.

$\mu$ C/OS-III also provides additional features that better exploit the capabilities of today’s newer processors. Specifically,  $\mu$ C/OS-III was designed with 32-bit processors in mind, although it certainly works well with 16- and even several 8-bit processors.

## **μC/OS-III GOALS**

The main goal of μC/OS-III is to provide a best-in-class real-time kernel that literally shaves months of development time from an embedded-product schedule. Using a commercial real-time kernel such as μC/OS-III provides a solid foundation and framework to the design engineer dealing with the growing complexity of embedded designs.

Another goal for μC/OS-III, and therefore this book, is to explain inner workings of a commercial-grade kernel. This understanding will assist the reader in making logical design decisions and informed tradeoffs between hardware and software that make sense.



# Chapter

# 1

## Introduction

Real-time systems are systems whereby the correctness of the computed values and their timeliness are at the forefront. There are two types of real-time systems, hard and soft real time.

What differentiates hard and soft real-time systems is their tolerance to missing deadlines and the consequences associated with those misses. Correctly computed values after a deadline has passed are often useless.

For hard real-time systems, missing deadlines is not an option. In fact, in many cases, missing a deadline often results in catastrophe, which may involve human lives. For soft real-time systems, however, missing deadlines is generally not as critical.

Real-time applications cover a wide range, but many real-time systems are embedded. An embedded system is a computer built into a system and not acknowledged by the user as being a computer. The following list shows just a few examples of embedded systems:

### **Aerospace**

- Flight management systems
- Jet engine controls
- Weapons systems

### **Audio**

- MP3 players
- Amplifiers and tuners

### **Automotive**

- Antilock braking systems
- Climate control
- Engine controls
- Navigation systems (GPS)

### **Communications**

- Routers
- Switches
- Cell phones

### **Computer peripherals**

- Printers
- Scanners

### **Domestic**

- Air conditioning units
- Thermostats
- White goods

### **Office automation**

- FAX machines / copiers

### **Process control**

- Chemical plants
- Factory automation
- Food processing

### **Robots**

### **Video**

- Broadcasting equipment
- HD Televisions

### **And many more**

Real-time systems are typically more complicated to design, debug, and deploy than non-real-time systems.

## 1-1 FOREGROUND/BACKGROUND SYSTEMS

Small systems of low complexity are typically designed as foreground/background systems or super-loops. An application consists of an infinite loop that calls modules (i.e., tasks) to perform the desired operations (background). Interrupt Service Routines (ISRs) handle asynchronous events (foreground). Foreground is also called interrupt level; background is called task level.

Critical operations that should be performed at the task level must unfortunately be handled by the ISRs to ensure that they are dealt with in a timely fashion. This causes ISRs to take longer than they should. Also, information for a background module that an ISR makes available is not processed until the background routine gets its turn to execute, which is called the task-level response. The worst-case task-level response time depends on how long a background loop takes to execute since the execution time of typical code is not constant, the time for successive passes through a portion of the loop is nondeterministic. Furthermore, if a code change is made, the timing of the loop is affected.

Most high-volume and low-cost microcontroller-based applications (e.g., microwave ovens, telephones, toys, etc.) are designed as foreground/background systems.

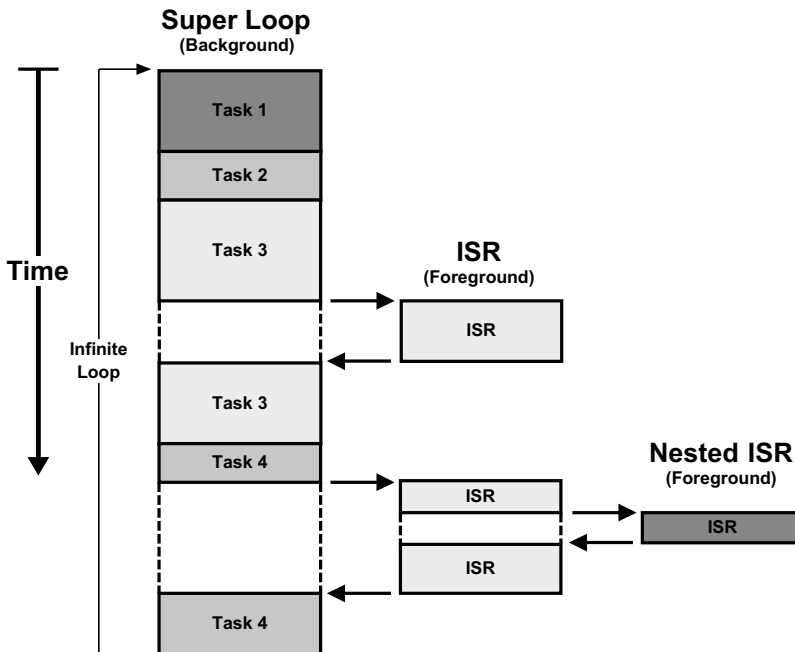

Figure 1-1 Foreground/Background (SuperLoops) systems

## 1-2 REAL-TIME KERNELS

A real-time kernel is software that manages the time and resources of a microprocessor, microcontroller or Digital Signal Processor (DSP).

The design process of a real-time application involves splitting the work into tasks, each responsible for a portion of the job. A task (also called a thread) is a simple program that thinks it has the Central Processing Unit (CPU) completely to itself. On a single CPU, only one task executes at any given time.

The kernel is responsible for the management of tasks. This is called multitasking. Multitasking is the process of scheduling and switching the CPU between several tasks. The CPU switches its attention between several sequential tasks. Multitasking provides the illusion of having multiple CPUs and maximizes the use of the CPU. Multitasking also helps in the creation of modular applications. One of the most important aspects of multitasking is that it allows the application programmer to manage the complexity inherent in real-time applications. Application programs are easier to design and maintain when multitasking is used.

$\mu\text{C}/\text{OS-III}$  is a preemptive kernel, which means that  $\mu\text{C}/\text{OS-III}$  always runs the most important task that is ready to run as shown in Figure 1-2.

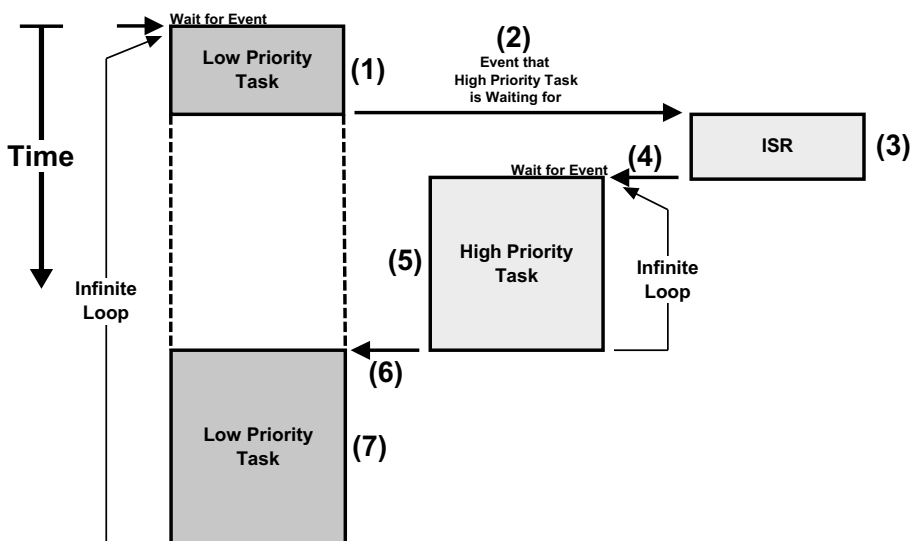

Figure 1-2  $\mu\text{C}/\text{OS-III}$  is a preemptive kernel

- F1-2(1) A low-priority task is executing.
- F1-2(2) An interrupt occurs, and the CPU vectors to the ISR responsible for servicing the interrupting device.
- F1-2(3) The ISR services the interrupt device, but actually does very little work. The ISR will signal or send a message to a higher-priority task that will be responsible for most of the processing of the interrupting device. For example, if the interrupt comes from an Ethernet controller, the ISR simply signals a task, which will process the received packet.
- F1-2(4) When the ISR finishes,  $\mu\text{C}/\text{OS-III}$  notices that a more important task has been made ready to run by the ISR and will not return to the interrupted task, but instead context switch to the more important task.
- F1-2(5) The higher-priority task executes and performs the necessary processing in response to the interrupt device.
- F1-2(6) When the higher-priority task completes its work, it loops back to the beginning of the task code and makes a  $\mu\text{C}/\text{OS-III}$  function call to wait for the next interrupt from the device.
- F1-2(7) The low-priority task resumes exactly at the point where it was interrupted, not knowing what happened.

Kernels such as  $\mu\text{C}/\text{OS-III}$  are also responsible for managing communication between tasks, and managing system resources (memory and I/O devices).

A kernel adds overhead to a system because the services provided by the kernel require time to execute. The amount of overhead depends on how often these services are invoked. In a well-designed application, a kernel uses between 2% and 4% of a CPU's time. And, since  $\mu\text{C}/\text{OS-III}$  is software that is added to an application, it requires extra ROM (code space) and RAM (data space).

Low-end single-chip microcontrollers are generally not able to run a real-time kernel such as  $\mu\text{C}/\text{OS-III}$  since they have access to very little RAM.  $\mu\text{C}/\text{OS-III}$  requires between 1 Kbyte and 4 Kbytes of RAM, plus each task requires its own stack space. It is possible for  $\mu\text{C}/\text{OS-III}$  to work on processors having as little as 4 Kbytes of RAM.

Finally,  $\mu\text{C}/\text{OS-III}$  allows for better use of the CPU by providing approximately 70 indispensable services. After designing a system using a real-time kernel such as  $\mu\text{C}/\text{OS-III}$ , you will not return to designing a foreground/background system.

### **1-3 RTOS (REAL-TIME OPERATING SYSTEM)**

A Real Time Operating System generally contains a real-time kernel and other higher-level services such as file management, protocol stacks, a Graphical User Interface (GUI), and other components. Most additional services revolve around I/O devices.

Micrium offers a complete suite of RTOS components including:  $\mu\text{C}/\text{FS}$  (an Embedded File System),  $\mu\text{C}/\text{TCP-IP}$  (a TCP/IP stack),  $\mu\text{C}/\text{GUI}$  (a Graphical User Interface),  $\mu\text{C}/\text{USB}$  (a USB device, host and OTG stack), and more. Most of these components are designed to work standalone. Except for  $\mu\text{C}/\text{TCP-IP}$ , a real-time kernel is not required to use the components in an application. In fact, users can pick and choose only the components required for the application. Contact Micrium ([www.micrium.com](http://www.micrium.com)) for additional details and pricing.

### **1-4 $\mu\text{C}/\text{OS-III}$**

$\mu\text{C}/\text{OS-III}$  is a scalable, ROMable, preemptive real-time kernel that manages an unlimited number of tasks.  $\mu\text{C}/\text{OS-III}$  is a third-generation kernel, offering all of the services expected from a modern real-time kernel including resource management, synchronization, inter-task communication, and more. However,  $\mu\text{C}/\text{OS-III}$  also offers many unique features not found in other real-time kernels, such as the ability to perform performance measurements at run time, directly signal or send messages to tasks, and pending (i.e., waiting) on such multiple kernel objects as semaphores and message queues.

Here is a list of features provided by  $\mu\text{C}/\text{OS-III}$ :

**Source Code:**  $\mu\text{C}/\text{OS-III}$  is provided in ANSI-C source form to licensees. The source code for  $\mu\text{C}/\text{OS-III}$  is arguably the cleanest and most consistent kernel code available. Clean source is part of the corporate culture at Micrium. Although many commercial kernel vendors provide source code for their products, unless the code follows strict coding standards and is accompanied by complete documentation with examples to show how the

code works, these products may be cumbersome and difficult to harness. With this book, you will gain a deep understanding of the inner workings of  $\mu\text{C}/\text{OS-III}$ , which will protect your investment.

**Intuitive Application Programming Interface (API):**  $\mu\text{C}/\text{OS-III}$  is highly intuitive. Once familiar with the consistent coding conventions used, it is simple to predict the functions to call for the services required, and even predict which arguments are needed. For example, a pointer to an object is always the first argument, and a pointer to an error code is always the last one.

**Preemptive multitasking:**  $\mu\text{C}/\text{OS-III}$  is a preemptive multi-tasking kernel and therefore,  $\mu\text{C}/\text{OS-III}$  always runs the most important ready-to-run task.

**Round robin scheduling of tasks at equal priority:**  $\mu\text{C}/\text{OS-III}$  allows multiple tasks to run at the same priority level. When multiple tasks at the same priority are ready to run, and that priority level is the most important level,  $\mu\text{C}/\text{OS-III}$  runs each task for a user-specified time called a time quanta. Each task can define its own time quanta, and a task can also give up the CPU to another task at the same priority if it does not require the full time quanta.

**Low interrupt disable time:**  $\mu\text{C}/\text{OS-III}$  has a number of internal data structures and variables that it needs to access atomically. To ensure this,  $\mu\text{C}/\text{OS-III}$  is able to protect these critical regions by locking the scheduler instead of disabling interrupts. Interrupts are therefore disabled for very little time. This ensures that  $\mu\text{C}/\text{OS-III}$  is able to respond to some of the fastest interrupt sources.

**Deterministic:** Interrupt response with  $\mu\text{C}/\text{OS-III}$  is deterministic. Also, execution times of most services provided by  $\mu\text{C}/\text{OS-III}$  are deterministic.

**Scalable:** The footprint (both code and data) can be adjusted based on the requirements of the application. This assumes access to the source code for  $\mu\text{C}/\text{OS-III}$  since adding and removing features (i.e., services) is performed at compile time through approximately 40 `#defines` (see `OS_CFG.H`).  $\mu\text{C}/\text{OS-III}$  also performs a number of run-time checks on arguments passed to  $\mu\text{C}/\text{OS-III}$  services. Specifically,  $\mu\text{C}/\text{OS-III}$  verifies that the user is not passing `NULL` pointers, not calling task level services from ISRs, that arguments are within allowable range, and options specified are valid, etc.. These checks can be disabled (at compile time) to further reduce the code footprint and improve performance. The fact that  $\mu\text{C}/\text{OS-III}$  is scalable allows it to be used in a wide range of applications and projects.

**Portable:**  $\mu\text{C}/\text{OS-III}$  can be ported to a large number of CPU architectures. Most  $\mu\text{C}/\text{OS-II}$  ports are easily converted to work on  $\mu\text{C}/\text{OS-III}$  with minimal changes in just a matter of minutes and therefore benefit from more than 45 CPU architectures already supported by  $\mu\text{C}/\text{OS-II}$ .

**ROMable:**  $\mu\text{C}/\text{OS-III}$  was designed especially for embedded systems and can be ROMed along with the application code.

**Run-time configurable:**  $\mu\text{C}/\text{OS-III}$  allows the user to configure the kernel at run time. Specifically, all kernel objects such as tasks, stacks, semaphores, event-flag groups, message queues, number of messages, mutual exclusion semaphores, memory partitions and timers, are allocated by the user at run time. This prevents over-allocating resources at compile time.

**Unlimited number of tasks:**  $\mu\text{C}/\text{OS-III}$  supports an unlimited number of tasks. From a practical standpoint, however, the number of tasks is actually limited by the amount of memory (both code and data space) that the processor has access to. Each task requires its own stack space and,  $\mu\text{C}/\text{OS-III}$  provides features to allow stack growth of the tasks to be monitored at run-time.

$\mu\text{C}/\text{OS-III}$  does not impose any limitations on the size of each task, except that there be a minimum size based on the CPU used.

**Unlimited number of priorities:**  $\mu\text{C}/\text{OS-III}$  supports an unlimited number of priority levels. However, configuring  $\mu\text{C}/\text{OS-III}$  for between 32 and 256 different priority levels is more than adequate for most applications.

**Unlimited number of kernel objects:**  $\mu\text{C}/\text{OS-III}$  allows for any number of tasks, semaphores, mutual exclusion semaphores, event flags, message queues, timers, and memory partitions. The user at run-time allocates all kernel objects.

**Services:**  $\mu\text{C}/\text{OS-III}$  provides all the services expected from a high-end real-time kernel, such as task management, time management, semaphores, event flags, mutexes, message queues, software timers, fixed-size memory pools, etc.

**Mutual Exclusion Semaphores (Mutexes):** Mutexes are provided for resource management. Mutexes are special types of semaphores that have built-in priority inheritance, which eliminate unbounded priority inversions. Accesses to a mutex can be nested and therefore, a task can acquire the same mutex up to 250 times. Of course, the mutex owner needs to release the mutex an equal number of times.

**Nested task suspension:**  $\mu$ C/OS-III allows a task to suspend itself or another task. Suspending a task means that the task will not be allowed to execute until the task is resumed by another task. Suspension can be nested up to 250 levels deep. In other words, a task can suspend another task up to 250 times. Of course, the task must be resumed an equal number of times for it to become eligible to run on the CPU.

**Software timers:** Define any number of “one-shot” and/or “periodic” timers. Timers are countdown counters that perform a user-definable action upon counting down to 0. Each timer can have its own action and, if a timer is periodic, the timer is automatically reloaded and the action is executed every time the countdown reaches zero.

**Pend on multiple objects:**  $\mu$ C/OS-III allows an application to wait (i.e., pend) on multiple events at the same time. Specifically, a task can wait on multiple semaphores and/or message queues to be posted. The waiting task wakes up as soon as one of the events occurs.

**Task Signals:**  $\mu$ C/OS-III allows an ISR or task to directly signal a task. This avoids having to create an intermediate kernel object such as a semaphore or event flag just to signal a task, and results in better performance.

**Task Messages:**  $\mu$ C/OS-III allows an ISR or a task to send messages directly to a task. This avoids having to create and use a message queue, and also results in better performance.

**Task registers:** Each task can have a user-definable number of “task registers.” Task registers are different than CPU registers. Task registers can be used to hold “errno” type variable, IDs, interrupt disable time measurement on a per-task basis, and more.

**Error checking:**  $\mu$ C/OS-III verifies that **NULL** pointers are not passed, that the user is not calling task-level services from ISRs, that arguments are within allowable range, that options specified are valid, that a handler is passed to the proper object as part of the arguments to services that manipulate the desired object, and more. Each  $\mu$ C/OS-III API function returns an error code concerning the outcome of the function call.

**Built-in performance measurements:**  $\mu$ C/OS-III has built-in features to measure the execution time of each task, stack usage of each task, number of times a task executes, CPU usage, ISR-to-task and task-to-task response time, peak number of entries in certain lists, interrupt disable and scheduler lock time on a per-task basis, and more.



**Can easily be optimized:**  $\mu\text{C}/\text{OS-III}$  was designed so that it could easily be optimized based on the CPU architecture. Most data types used in  $\mu\text{C}/\text{OS-III}$  can be changed to make better use of the CPU's natural word size. Also, the priority resolution algorithm can easily be written in assembly language to benefit from special instructions such as bit set and clear, as well as count-leading-zeros (CLZ), or find-first-one (FF1) instructions.

**Deadlock prevention:** All of the  $\mu\text{C}/\text{OS-III}$  "pend" services include timeouts, which help avoid deadlocks.

**Tick handling at task level:** The clock tick manager in  $\mu\text{C}/\text{OS-III}$  is accomplished by a task that receives a trigger from an ISR. Handling delays and timeouts by a task greatly reduces interrupt latency. Also,  $\mu\text{C}/\text{OS-III}$  uses a hashed delta list mechanism, which further reduces the amount of overhead in processing delays and timeouts of tasks.

**User definable hooks:**  $\mu\text{C}/\text{OS-III}$  allows the port and application programmer to define "hook" functions, which are called by  $\mu\text{C}/\text{OS-III}$ . A hook is simply a defined function that allows the user to extend the functionality of  $\mu\text{C}/\text{OS-III}$ . One such hook is called during a context switch, another when a task is created, yet another when a task is deleted, etc.

**Timestamps:** For time measurements,  $\mu\text{C}/\text{OS-III}$  requires that a 16-bit or 32-bit free running counter be made available. This counter can be read at run time to make time measurements of certain events. For example, when an ISR posts a message to a task, the timestamp counter is automatically read and saved as part of the message posted. When the recipient receives the message, the timestamp is provided to the recipient, and by reading the current timestamp, the time it took for the message to be received can be determined.

**Built-in support for Kernel Awareness debuggers:** This feature allows kernel awareness debuggers to examine and display  $\mu\text{C}/\text{OS-III}$  variables and data structures in a user-friendly way, but only when the debugger hits a breakpoint. Instead of a static view of the environment the kernel awareness support in  $\mu\text{C}/\text{OS-III}$  is also used by  $\mu\text{C}/\text{Probe}$  to display the same information at run-time.

**Object names:** Each  $\mu\text{C}/\text{OS-III}$  kernel object can have a name associated with it. This makes it easy to recognize what the object is assigned to. Assign an ASCII name to a task, a semaphore, a mutex, an event flag group, a message queue, a memory partition, and a timer. The object name can have any length, but must be NUL terminated.

## 1-5 $\mu$ C/OS, $\mu$ C/OS-II AND $\mu$ C/OS-III FEATURES COMPARISON

Table 1-1 shows the evolution of  $\mu$ C/OS over the years, comparing the features available in each version.

| Feature   | $\mu$ C/OS | $\mu$ C/OS-II | $\mu$ C/OS-III          |
|---|------------|---------------|-------------------------|
| Year introduced   | 1992       | 1998          | 2009                    |
| Book  | Yes        | Yes           | Yes                     |
| Source code available                                     | Yes        | Yes           | Yes<br>(Licensees only) |
| Preemptive Multitasking                                   | Yes        | Yes           | Yes                     |
| Maximum number of tasks                                   | 64         | 255           | Unlimited               |
| Number of tasks at each priority level                    | 1          | 1             | Unlimited               |
| Round Robin Scheduling                                    | No         | No            | Yes                     |
| Semaphores  | Yes        | Yes           | Yes                     |
| Mutual Exclusion Semaphores                               | No         | Yes           | Yes (Nestable)          |
| Event Flags   | No         | Yes           | Yes                     |
| Message Mailboxes   | Yes        | Yes           | No (not needed)         |
| Message Queues  | Yes        | Yes           | Yes                     |
| Fixed Sized Memory Management                             | No         | Yes           | Yes                     |
| Signal a task without requiring a semaphore               | No         | No            | Yes                     |
| Send messages to a task without requiring a message queue | No         | No            | Yes                     |
| Software Timers   | No         | Yes           | Yes                     |
| Task suspend/resume                                       | No         | Yes           | Yes (Nestable)          |
| Deadlock prevention                                       | Yes        | Yes           | Yes                     |
| Scalable  | Yes        | Yes           | Yes                     |
| Code Footprint  | 3K to 8K   | 6K to 26K     | 6K to 20K               |
| Data Footprint  | 1K+        | 1K+           | 1K+                     |
| ROMable   | Yes        | Yes           | Yes                     |

| <b>Feature</b>  | <b>μC/OS</b> | <b>μC/OS-II</b>          | <b>μC/OS-III</b>        |
|---|--------------|--------------------------|-------------------------|
| Run-time configurable   | No           | No                       | Yes                     |
| Compile-time configurable   | Yes          | Yes                      | Yes                     |
| ASCII names for each kernel object  | No           | Yes                      | Yes                     |
| Pend on multiple objects  | No           | Yes                      | Yes                     |
| Task registers  | No           | Yes                      | Yes                     |
| Built-in performance measurements   | No           | Limited                  | Extensive               |
| User definable hook functions   | No           | Yes                      | Yes                     |
| Time stamps on posts  | No           | No                       | Yes                     |
| Built-in Kernel Awareness support   | No           | Yes                      | Yes                     |
| Optimizable Scheduler in assembly language                                    | No           | No                       | Yes                     |
| Tick handling at task level   | No           | No                       | Yes                     |
| Source code available   | Yes          | Yes                      | Yes                     |
| Number of services  | ~20          | ~90                      | ~70                     |
| MISRA-C:1998  | No           | Yes<br>(except 10 rules) | N/A                     |
| MISRA-C:2004  | No           | No                       | Yes<br>(except 7 rules) |
| DO178B Level A and EUROCAE ED-12B   | No           | Yes                      | In progress             |
| Medical FDA pre-market notification (510(k))<br>and pre-market approval (PMA) | No           | Yes                      | In progress             |
| SIL3/SIL4 IEC for transportation and nuclear systems                          | No           | Yes                      | In progress             |
| IEC-61508   | No           | Yes                      | In progress             |

Table 1-1 μC/OS-II and μC/OS-III Features Comparison Chart

## **1-6 HOW THE BOOK IS ORGANIZED**

This book consists of two books in one.

Part I describes  $\mu\text{C}/\text{OS-III}$  and is not tied to any specific CPU architecture. Here, the reader will learn about real-time kernels through  $\mu\text{C}/\text{OS-III}$ . Specifically, critical sections, task management, the ready list, scheduling, context switching, interrupt management, wait lists, time management, timers, resource management, synchronization, memory management, how to use  $\mu\text{C}/\text{OS-III}$ 's API, how to configure  $\mu\text{C}/\text{OS-III}$ , and how to port  $\mu\text{C}/\text{OS-III}$  to different CPU architectures, are all covered.

Part II describes the port of a popular CPU architecture. Here, learn about this CPU architecture and how  $\mu\text{C}/\text{OS-III}$  gets the most out of the CPU. Examples are provided to actually run code on the evaluation board that is available with this book.

As I just mentioned, this book assumes the presence of an evaluation board that allows the user to experiment with the wonderful world of real-time kernels, and specifically  $\mu\text{C}/\text{OS-III}$ . The book and board are complemented by a full set of tools that are provided free of charge either in a companion CD/DVD, or downloadable through the Internet. The tools and the use of  $\mu\text{C}/\text{OS-III}$  are free as long as they are used with the evaluation board, and there is no commercial intent to use them on a project. In other words, there is no additional charge except for the initial cost of the book, evaluation board and tools, as long as they are used for educational purposes.

The book also comes with a trial version of an award-winning tool from Micrium called  $\mu\text{C}/\text{Probe}$ . The trial version allows the user to monitor and change up to five variables in a target system.

## **1-7 $\mu\text{C}/\text{PROBE}$**

$\mu\text{C}/\text{Probe}$  is a Microsoft Windows™ based application that enables the user to visualize variables in a target at run time. Specifically, display or change the value of any variable in a system while the target is running. These variables can be displayed using such graphical elements as gauges, meters, bar graphs, virtual LEDs, numeric indicators, and many more. Sliders, switches, and buttons can be used to change variables. This is accomplished without the user writing a single line of code!

$\mu$ C/Probe interfaces to any target (8-, 16-, 32-, 64-bit, or even DSPs) through one of the many interfaces supported (J-Tag, RS-232C, USB, Ethernet, etc.).  $\mu$ C/Probe displays or changes any variable (as long as they are global) in the application, including  $\mu$ C/OS-III's internal variables.

$\mu$ C/Probe works with any compiler/assembler/linker able to generate an ELF/DWARF or IEEE695 file. This is the exact same file that the user will download to the evaluation board or a final target. From this file,  $\mu$ C/Probe is able to extract symbolic information about variables, and determine where variables are stored in RAM or ROM.

$\mu$ C/Probe also allows users to log the data displayed into a file for analysis of the collected data at a later time.  $\mu$ C/Probe also provides  $\mu$ C/OS-III kernel awareness as a built-in feature.

The trial version that accompanies the book is limited to the display or change of up to five variables.

$\mu$ C/Probe is a tool that serious embedded software engineers should have in their toolbox. The full version of  $\mu$ C/Probe is included when licensing  $\mu$ C/OS-III. See [www.micrium.com](http://www.micrium.com) for more details.

## **1-8 CONVENTIONS**

There are a number of conventions in this book.

First, notice that when a specific element in a figure is referenced, the element has a number next to it in parenthesis. A description of this element follows the figure and in this case, the letter "F" followed by the figure number, and then the number in parenthesis. For example, F3-4(2) indicates that this description refers to Figure 3-4 and the element (2) in that figure. This convention also applies to listings (starts with an "L") and tables (starts with a "T").

Second, notice that sections and listings are started where it makes sense. Specifically, do not be surprised to see the bottom half of a page empty. New sections begin on a new page, and listings are found on a single page, instead of breaking listings on two pages.

Third, code quality is something I've been avidly promoting throughout my whole career. At Micrium, we pride ourselves in having the cleanest code in the industry. Examples of this are seen in this book. I created and published a coding standard in 1992 that was published

in the original  $\mu\text{C}/\text{OS}$  book. This standard has evolved over the years, but the spirit of the standard has been maintained throughout. The Micrium coding standard is available for download from the Micrium website, [www.micrium.com](http://www.micrium.com)

One of the conventions used is that all functions, variables, macros and `#define` constants are prefixed by “OS” (which stands for Operating System) followed by the acronym of the module (e.g., `Sem`), and then the operation performed by the function. For example `OSSemPost()` indicates that the function belongs to the OS ( $\mu\text{C}/\text{OS-III}$ ), that it is part of the Semaphore services, and specifically that the function performs a `Post` (i.e., signal) operation. This allows all related functions to be grouped together in the reference manual, and makes those services intuitive to use.

Notice that signaling or sending a message to a task is called posting, and waiting for a signal or a message is called pending. In other words, an ISR or a task signals or sends a message to another task by using `OS???Post()`, where `???` is the type of service: `Sem`, `TaskSem`, `Flag`, `Mutex`, `Q`, and `TaskQ`. Similarly, a task can wait for a signal or a message by calling `OS???Pend()`.

## 1-9 CHAPTER CONTENTS

Figure 1-3 shows the layout and flow of Part I of the book. This diagram should be useful to understand the relationship between chapters. The first column on the left indicates chapters that should be read in order to understand  $\mu\text{C}/\text{OS-III}$ 's structure. The second column shows chapters that are related to additional services provided by  $\mu\text{C}/\text{OS-III}$ . The third column relates to chapters that will help port  $\mu\text{C}/\text{OS-III}$  to different CPU architectures. The top of the fourth column explains how to obtain valuable run-time and compile-time statistics from  $\mu\text{C}/\text{OS-III}$ . This is especially useful if developing a kernel awareness plug-in for a debugger, or using  $\mu\text{C}/\text{Probe}$ . The middle of column four contains the  $\mu\text{C}/\text{OS-III}$  API and configuration manuals. Reference these sections regularly when designing a product using  $\mu\text{C}/\text{OS-III}$ . Finally, the bottom of the last column contains miscellaneous appendices.

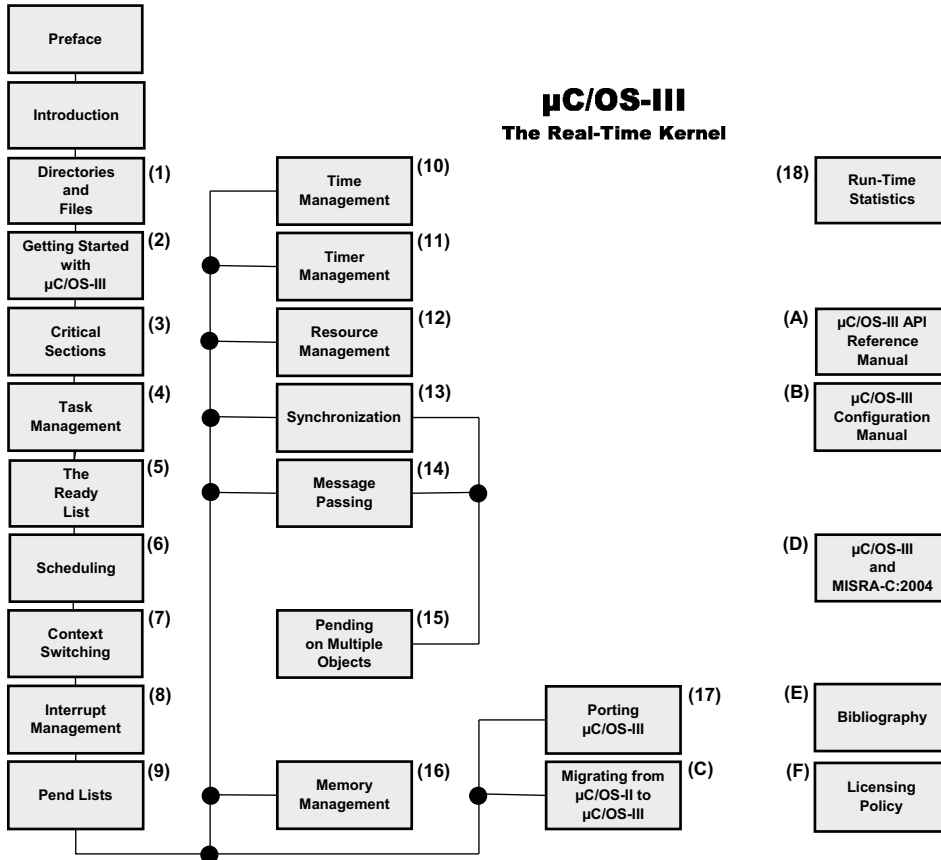

Figure 1-3 μC/OS-III Book Layout

**Chapter 1, Introduction.** This chapter.

**Chapter 2, Directories and Files.** This chapter explains the directory structure and files needed to build a μC/OS-III-based application. Learn about the files that are needed, where they should be placed, which module does what, and more.

**Chapter 3, Getting Started with μC/OS-III.** In this chapter, learn how to properly initialize and start a μC/OS-III-based application.

**Chapter 4, Critical Sections.** This chapter explains what critical sections are, and how they are protected.

**Chapter 5, Task Management.** This chapter is an introduction to one of the most important aspects of a real-time kernel, the management of tasks in a multitasking environment.

**Chapter 6, The Ready List.** In this chapter, learn how  $\mu\text{C}/\text{OS-III}$  efficiently keeps track of all of the tasks that are waiting to execute on the CPU.

**Chapter 7, Scheduling.** This chapter explains the scheduling algorithms used by  $\mu\text{C}/\text{OS-III}$ , and how it decides which task will run next.

**Chapter 8, Context Switching.** This chapter explains what a context switch is, and describes the process of suspending execution of a task and resuming execution of a higher-priority task.

**Chapter 9, Interrupt Management.** Here is how  $\mu\text{C}/\text{OS-III}$  deals with interrupts and an overview of services that are available from Interrupt Service Routines (ISRs). Learn how  $\mu\text{C}/\text{OS-III}$  supports nearly any interrupt controller.

**Chapter 10, Pend Lists (or Wait Lists).** Tasks that are not able to run are most likely blocked waiting for specific events to occur. Pend Lists (or wait lists), are used to keep track of tasks that are waiting for a resource or event. This chapter describes how  $\mu\text{C}/\text{OS-III}$  maintains these lists.

**Chapter 11, Time Management.** In this chapter, learn about  $\mu\text{C}/\text{OS-III}$ 's services that allow users to suspend a task until some time expires. With  $\mu\text{C}/\text{OS-III}$ , specify to delay execution of a task for an integral number of clock ticks or until the clock-tick counter reaches a certain value. The chapter will also show how a delayed task can be resumed, and describe how to get the current value of the clock tick counter, or set this counter, if needed.

**Chapter 12, Timer Management.**  $\mu\text{C}/\text{OS-III}$  allows users to define any number of software timers. When a timer expires, a function can be called to perform some action. Timers can be configured to be either periodic or one-shot. This chapter also explains how the timer-management module works.

**Chapter 13, Resource Management.** In this chapter, learn different techniques so that tasks share resources. Each of these techniques has advantages and disadvantages that will be discussed. This chapter also explains the internals of semaphores, and mutual exclusion semaphore management.



**Chapter 14, Synchronization.**  $\mu\text{C}/\text{OS-III}$  provides two types of services for synchronization: semaphores and event flags and these are explained in this chapter, as well as what happens when calling specific services provided in this module.

**Chapter 15, Message Passing.**  $\mu\text{C}/\text{OS-III}$  allows a task or an ISR to send messages to a task. This chapter describes some of the services provided by the message queue management module.

**Chapter 16, Pending on multiple objects.** In this chapter, see how  $\mu\text{C}/\text{OS-III}$  allows an application to pend (or wait) on multiple kernel objects (semaphores or message queues) at the same time. This feature makes the waiting task ready to run as soon as any one of the objects is posted (i.e., OR condition), or a timeout occurs.

**Chapter 17, Memory Management.** Here is how  $\mu\text{C}/\text{OS-III}$ 's fixed-size memory partition manager can be used to allocate and deallocate dynamic memory.

**Chapter 18, Porting  $\mu\text{C}/\text{OS-III}$ .** This chapter explains, in generic terms, how to port  $\mu\text{C}/\text{OS-III}$  to any CPU architecture.

**Chapter 19, Run-Time Statistics.**  $\mu\text{C}/\text{OS-III}$  provides a wealth of information about the run-time environment, such as number of context switches, CPU usage (as a percentage), stack usage on a per-task basis,  $\mu\text{C}/\text{OS-III}$  RAM usage, maximum interrupt disable time, maximum scheduler lock time, and more.

**Appendix A,  $\mu\text{C}/\text{OS-III}$  API Reference Manual.** This appendix provides a alphabetical reference for all user-available services provided by  $\mu\text{C}/\text{OS-III}$ .

**Appendix B,  $\mu\text{C}/\text{OS-III}$  Configuration Manual.** This appendix describes how to configure a  $\mu\text{C}/\text{OS-III}$ -based application. `OS_CFG.H` configures the  $\mu\text{C}/\text{OS-III}$  features (semaphores, queues, event flags, etc.), while `OS_CFG_APP.H` configures the run-time characteristics (tick rate, tick wheel size, stack size for the idle task, etc.).

**Appendix C, Migrating from  $\mu\text{C}/\text{OS-II}$  to  $\mu\text{C}/\text{OS-III}$ .**  $\mu\text{C}/\text{OS-III}$  has its roots in  $\mu\text{C}/\text{OS-II}$  and, in fact, most of the  $\mu\text{C}/\text{OS-II}$  ports can be easily converted to  $\mu\text{C}/\text{OS-III}$ . However, most APIs have changed from  $\mu\text{C}/\text{OS-II}$  to  $\mu\text{C}/\text{OS-III}$ , and this appendix describes some of the differences.

**Appendix D, MISRA-C:2004 rules and  $\mu\text{C}/\text{OS-III}$ .**  $\mu\text{C}/\text{OS-III}$  follows most of the MISRA-C:2004, except for 7 of these rules.

**Appendix E, Bibliography.**

**Appendix F, Licensing  $\mu$ C/OS-III.**

## **1-10 LICENSING**

This book contains  $\mu$ C/OS-III precompiled in linkable object form, an evaluation board, and tools (compiler/assembler/linker/debugger). Use  $\mu$ C/OS-III for free, as long as it is only used with the evaluation board that accompanies this book. You will need to purchase a license when using this code in a commercial project, where the intent is to make a profit. Users do not pay anything beyond the price of the book, evaluation board and tools, as long as they are used for educational purposes.

You will need to license  $\mu$ C/OS-III if you intend to use  $\mu$ C/OS-III in a commercial product where you intend to make a profit. You need to purchase this license when you make the decision to use  $\mu$ C/OS-III in a design, not when you are ready to go to production.

If you are unsure about whether you need to obtain a license for your application, please contact Micrium and discuss your use with a sales representative.

## **1-11 CONTACTING MICRIUM**

Do not hesitate to contact Micrium should you have any licensing questions regarding  $\mu$ C/OS-III.

Micrium  
11290 Weston Road, Suite 306  
Weston, FL 33326  
USA

Phone: +1 954 217 2036  
Fax: +1 954 217 2037

E-mail: [Licensing@Micrium.com](mailto:Licensing@Micrium.com)  
Web: [www.Micrium.com](http://www.Micrium.com)

## Chapter

# 2

## Directories and Files

$\mu$ C/OS-III is fairly easy to use once it is understood exactly which source files are needed to make up a  $\mu$ C/OS-III-based application. This chapter will discuss the modules available for  $\mu$ C/OS-III and how everything fits together.

Figure 2-1 shows the  $\mu$ C/OS-III architecture and its relationship with hardware. Of course, in addition to the timer and interrupt controller, hardware would most likely contain such other devices as Universal Asynchronous Receiver Transmitters (UARTs), Analog to Digital Converters (ADCs), Ethernet controller(s) and more.

This chapter assumes development on a Windows®-based platform and makes references to typical Windows-type directory structures (also called Folder). However, since  $\mu$ C/OS-III is available in source form, it can also be used on Unix, Linux or other development platforms.

The names of the files are shown in upper case to make them “stand out”. However, file names are actually lower case.

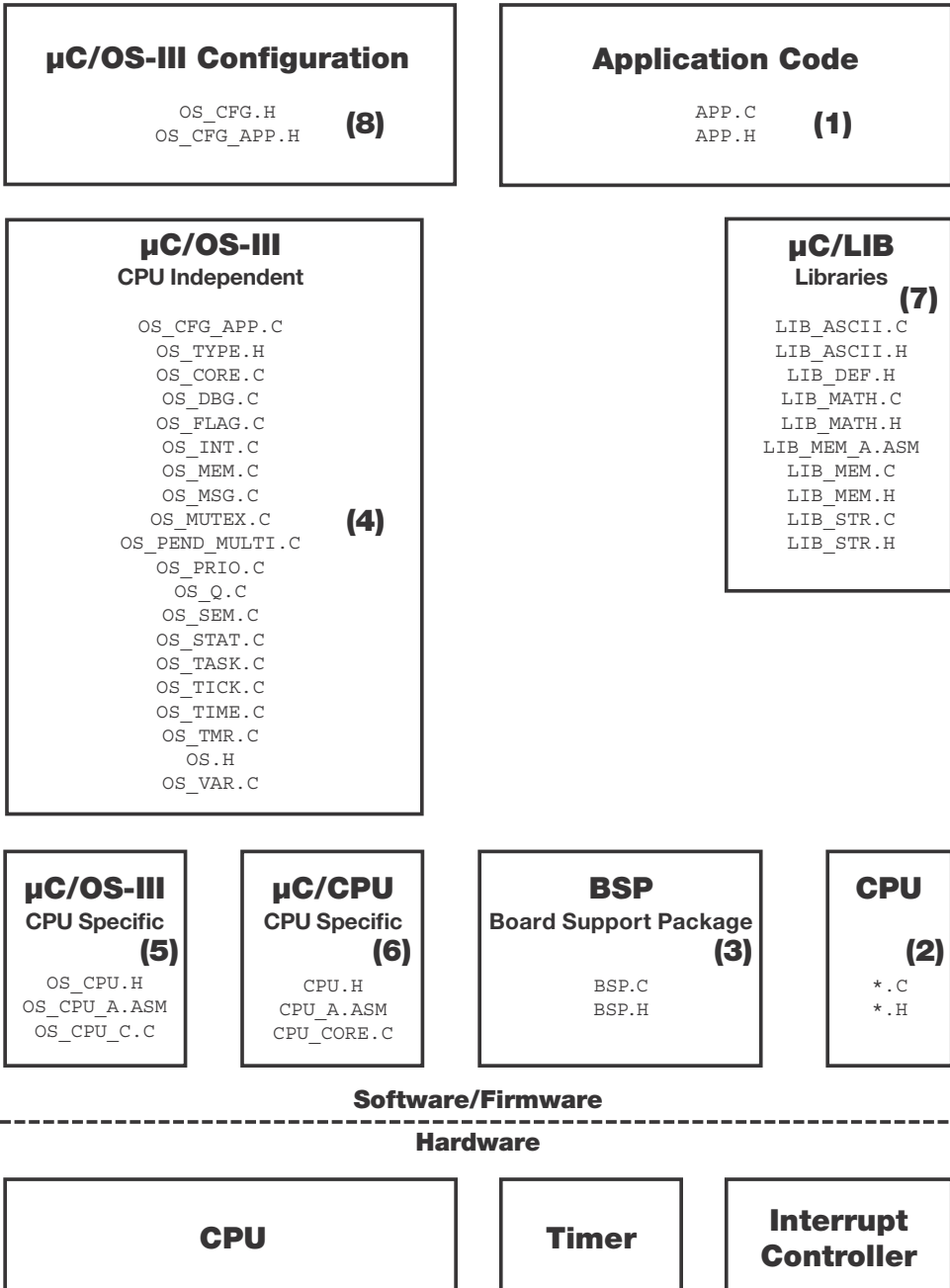

Figure 2-1 μC/OS-III Architecture

- F2-1(1) The application code consists of project or product files. For convenience, these are simply called **APP.C** and **APP.H**, however an application can contain any number of files that do not have to be called **APP.\***. The application code is typically where one would find `main()`.
- F2-1(2) Semiconductor manufacturers often provide library functions in source form for accessing the peripherals on their CPU or MCU. These libraries are quite useful and often save valuable time. Since there is no naming convention for these files, **\*.C** and **\*.H** are assumed.
- F2-1(3) The Board Support Package (BSP) is code that is typically written to interface to peripherals on a target board. For example such code can turn on and off Light Emitting Diodes (LEDs), turn on and off relays, or code to read switches, temperature sensors, and more.
- F2-1(4) This is the  $\mu$ C/OS-III processor-independent code. This code is written in highly portable ANSI C and is available to  $\mu$ C/OS-III licensees only.
- F2-1(5) This is the  $\mu$ C/OS-III code that is adapted to a specific CPU architecture and is called a port.  $\mu$ C/OS-III has its roots in  $\mu$ C/OS-II and benefits from being able to use most of the 45 or so ports available for  $\mu$ C/OS-II.  $\mu$ C/OS-II ports, however, will require small changes to work with  $\mu$ C/OS-III. These changes are described in Appendix C, "Migrating from  $\mu$ C/OS-II to  $\mu$ C/OS-III" on page 599.
- F2-1(6) At Micrium, we like to encapsulate CPU functionality. These files define functions to disable and enable interrupts, **CPU\_???** data types to be independent of the CPU and compiler used, and many more functions.
- F2-1(7)  $\mu$ C/LIB is of a series of source files that provide common functions such as memory copy, string, and ASCII-related functions. Some are occasionally used to replace **stdlib** functions provided by the compiler. The files are provided to ensure that they are fully portable from application to application and especially, from compiler to compiler.  $\mu$ C/OS-III does not use these files, but  $\mu$ C/CPU does.
- F2-1(8)  $\mu$ C/OS-III configuration files defines  $\mu$ C/OS-III features (**OS\_CFG.H**) to include in the application, and specifies the size of certain variables and data structures expected by  $\mu$ C/OS-III (**OS\_CFG\_APP.H**), such as idle task stack size, tick rate, size of the message pool, etc.

## 2-1 APPLICATION CODE

When Micrium provides example projects, they are placed in a directory structure shown below. Of course, a directory structure that suits a particular project/product can be used.

```
\Micrium
  \Software
    \EvalBoards
      \<manufacturer>
        \<board_name>
          \<compiler>
            \<project name>
              \*.*
```

### **\Micrium**

This is where we place all software components and projects provided by Micrium. This directory generally starts from the root directory of the computer.

### **\Software**

This sub-directory contains all software components and projects.

### **\EvalBoards**

This sub-directory contains all projects related to evaluation boards supported by Micrium.

### **\<manufacturer>**

This is the name of the manufacturer of the evaluation board. The “<” and “>” are not part of the actual name.

### **\<board name>**

This is the name of the evaluation board. A board from Micrium will typically be called **uC-Eval-xxxx** where “xxxx” represents the CPU or MCU used on the board. The “<” and “>” are not part of the actual name.

### **\<compiler>**

This is the name of the compiler or compiler manufacturer used to build the code for the evaluation board. The “<” and “>” are not part of the actual name.

**\<project name>**

The name of the project that will be demonstrated. For example, a simple  $\mu$ C/OS-III project might have a project name of “OS-Ex1”. The “-Ex1” represents a project containing only  $\mu$ C/OS-III. The project name OS-Probe-Ex1 contains  $\mu$ C/OS-III and  $\mu$ C/Probe.

**\\*.\***

These are the project source files. Main files can optionally be called **APP\*.\***. This directory also contains configuration files **OS\_CFG.H**, **OS\_CFG\_APP.H** and other required source files.

## 2-2 CPU

The directory where you will find semiconductor manufacturer peripheral interface source files is shown below. Any directory structure that suits the project/product may be used.

```
\Micrium
  \Software
    \CPU
      \<manufacturer>
        \<architecture>
          \*.*
```

**\Micrium**

The location of all software components and projects provided by Micrium.

**\Software**

This sub-directory contains all software components and projects.

**\CPU**

This sub-directory is always called CPU.

**\<manufacturer>**

Is the name of the semiconductor manufacturer providing the peripheral library.

**\<architecture>**

The name of the specific library, generally associated with a CPU name or an architecture.

**\\*.\***

Indicates library source files. The semiconductor manufacturer names the files.

## 2-3 BOARD SUPPORT PACKAGE (BSP)

The Board Support Package (BSP) is generally found with the evaluation or target board as it is specific to that board. In fact, when well written, the BSP should be used for multiple projects.

```
\Micrium
  \Software
    \EvalBoards
      \<manufacturer>
        \<board name>
          \<compiler>
            \BSP
              \*.*
```

### **\Micrium**

Contains all software components and projects provided by Micrium.

### **\Software**

This sub-directory contains all software components and projects.

### **\EvalBoards**

This sub-directory contains all projects related to evaluation boards.

### **\<manufacturer>**

The name of the manufacturer of the evaluation board. The “<” and “>” are not part of the actual name.

### **\<board name>**

The name of the evaluation board. A board from Micrium will typically be called **uC-Eval-xxxx** where “xxxx” is the name of the CPU or MCU used on the evaluation board. The “<” and “>” are not part of the actual name.

### **\<compiler>**

The name of the compiler or compiler manufacturer used to build code for the evaluation board. The “<” and “>” are not part of the actual name.



---

**\BSP**

This directory is always called BSP.

**\\*.\***

The source files of the BSP. Typically all of the file names start with BSP. It is therefore normal to find **BSP.C** and **BSP.H** in this directory. BSP code should contain such functions as LED control functions, initialization of timers, interface to Ethernet controllers and more.

## **2-4 $\mu$ C/OS-III, CPU INDEPENDENT SOURCE CODE**

The files in these directories are available to  $\mu$ C/OS-III licensees (see Appendix F, “Licensing Policy” on page 645).

```
\Micrium
  \Software
    \uCOS-III
      \Cfg\Template
        \OS_APP_HOOKS.C
        \OS_CFG.H
        \OS_CFG_APP.H
      \Source
        \OS_CFG_APP.C
        \OS_CORE.C
        \OS_DBG.C
        \OS_FLAG.C
        \OS_INT.C
        \OS_MEM.C
        \OS_MSG.C
        \OS_MUTEX.C
        \OS_PEND_MULTI.C
        \OS_PRIO.C
        \OS_Q.C
        \OS_SEM.C
        \OS_STAT.C
        \OS_TASK.C
        \OS_TICK.C
        \OS_TIME.C
```

**\OS\_TMR.C**  
**\OS\_VAR**  
**\OS.H**  
**\OS\_TYPE.H**

### **\Micrium**

Contains all software components and projects provided by Micrium.

### **\Software**

This sub-directory contains all software components and projects.

### **\uCOS-III**

This is the main  $\mu$ C/OS-III directory.

### **\Cfg\Template**

This directory contains examples of configuration files to copy to the project directory. You will then modify these files to suit the needs of the application.

**OS\_APP\_HOOKS.C** shows how to write hook functions that are called by  $\mu$ C/OS-III. Specifically, this file contains eight empty functions.

**OS\_CFG.H** specifies which features of  $\mu$ C/OS-III are available for an application. The file is typically copied into an application directory and edited based on which features are required from  $\mu$ C/OS-III. If  $\mu$ C/OS-III is provided in linkable object code format, this file will be provided to indicate features that are available in the object file. See Appendix B, “ $\mu$ C/OS-III Configuration Manual” on page 579.

**OS\_CFG\_APP.H** is a configuration file to be copied into an application directory and edited based on application requirements. This file enables the user to determine the size of the idle task stack, the tick rate, the number of messages available in the message pool and more. See Appendix B, “ $\mu$ C/OS-III Configuration Manual” on page 579.

### **\Source**

The directory containing the CPU-independent source code for  $\mu$ C/OS-III. All files in this directory should be included in the build (assuming you have the source code). Features that are not required will be compiled out based on the value of **#define** constants in **OS\_CFG.H** and **OS\_CFG\_APP.H**.

**OS\_CFG\_APP.C** declares variables and arrays based on the values in **OS\_CFG\_APP.H**.

**OS\_CORE.C** contains core functionality for  $\mu$ C/OS-III such as **OSInit()** to initialize  $\mu$ C/OS-III, **OSSched()** for the task level scheduler, **OSIntExit()** for the interrupt level scheduler, pend list (or wait list) management (see Chapter 10, “Pend Lists (or Wait Lists)” on page 177), ready list management (see Chapter 6, “The Ready List” on page 123), and more.

**OS\_DBG.C** contains declarations of constant variables used by a kernel aware debugger or  $\mu$ C/Probe.

**OS\_FLAG.C** contains the code for event flag management. See Chapter 14, “Synchronization” on page 251 for details about event flags.

**OS\_INT.C** contains code for the interrupt handler task, which is used when

**OS\_CFG\_ISR\_POST\_DEFERRED\_EN** (see **OS\_CFG.H**) is set to 1. See Chapter 9, “Interrupt Management” on page 157 for details regarding the interrupt handler task.

**OS\_MEM.C** contains code for the  $\mu$ C/OS-III fixed-size memory manager, see Chapter 17, “Memory Management” on page 323.

**OS\_MSG.C** contains code to handle messages.  $\mu$ C/OS-III provides message queues and task specific message queues. **OS\_MSG.C** provides common code for these two services. See Chapter 15, “Message Passing” on page 289.

**OS\_MUTEX.C** contains code to manage mutual exclusion semaphores, see Chapter 13, “Resource Management” on page 209.

**OS\_PEND\_MULTI.C** contains the code to allow code to pend on multiple semaphores or message queues. This is described in Chapter 16, “Pending On Multiple Objects” on page 313.

**OS\_PRIO.C** contains the code to manage the bitmap table used to keep track of which tasks are ready to run, see Chapter 6, “The Ready List” on page 123. This file can be replaced by an assembly language equivalent to improve performance if the CPU used provides bit set, clear and test instructions, and a count leading zeros instruction.

**OS\_Q.C** contains code to manage message queues. See Chapter 15, “Message Passing” on page 289.

**OS\_SEM.C** contains code to manage semaphores used for resource management and/or synchronization. See Chapter 13, “Resource Management” on page 209 and Chapter 14, “Synchronization” on page 251.

**OS\_STAT.C** contains code for the statistic task, which is used to compute the global CPU usage and the CPU usage of each of tasks. See Chapter 5, “Task Management” on page 75.

**OS\_TASK.C** contains code for managing tasks using `OSTaskCreate()`, `OSTaskDel()`, `OSTaskChangePrio()`, and many more. See Chapter 5, “Task Management” on page 75.

**OS\_TICK.C** contains code to manage tasks that have delayed themselves or that are pending on a kernel object with a timeout. See Chapter 5, “Task Management” on page 75.

**OS\_TIME.C** contains code to allow a task to delay itself until some time expires. See Chapter 11, “Time Management” on page 183.

**OS\_TMR.C** contains code to manage software timers. See Chapter 12, “Timer Management” on page 193.

**OS\_VAR.C** contains the  $\mu\text{C}/\text{OS-III}$  global variables. These variables are for  $\mu\text{C}/\text{OS-III}$  to manage and should not be accessed by application code.

**OS.H** contains the main  $\mu\text{C}/\text{OS-III}$  header file, which declares constants, macros,  $\mu\text{C}/\text{OS-III}$  global variables (for use by  $\mu\text{C}/\text{OS-III}$  only), function prototypes, and more.

**OS\_TYPE.H** contains declarations of  $\mu\text{C}/\text{OS-III}$  data types that can be changed by the port designed to make better use of the CPU architecture. In this case, the file would typically be copied to the port directory and then modified.  $\mu\text{C}/\text{OS-III}$  in linkable object library format provides this file to enable the user to know what each data type maps to. See Appendix B, “ $\mu\text{C}/\text{OS-III}$  Configuration Manual” on page 579.

---

## 2-5 $\mu$ C/OS-III, CPU SPECIFIC SOURCE CODE

The  $\mu$ C/OS-III port developer provides these files. See also Chapter 18, “Porting  $\mu$ C/OS-III” on page 335.

```
\Micrium
  \Software
    \uCOS-III
      \Ports
        \<architecture>
          \<compiler>
            \OS_CPU.H
            \OS_CPU_A.ASM
            \OS_CPU_C.C
```

### **\Micrium**

Contains all software components and projects provided by Micrium.

### **\Software**

This sub-directory contains all software components and projects.

### **\uCOS-III**

The main  $\mu$ C/OS-III directory.

### **\Ports**

The location of port files for the CPU architecture(s) to be used.

### **\<architecture>**

This is the name of the CPU architecture that  $\mu$ C/OS-III was ported to. The “<” and “>” are not part of the actual name.

### **\<compiler>**

The name of the compiler or compiler manufacturer used to build code for the port. The “<” and “>” are not part of the actual name.

The files in this directory contain the  $\mu$ C/OS-III port, see Chapter 18, “Porting  $\mu$ C/OS-III” on page 335 for details on the contents of these files.

**OS\_CPU.H** contains a macro declaration for `OS_TASK_SW()`, as well as the function prototypes for at least the following functions: `OSCtxSw()`, `OSIntCtxSw()` and `OSStartHighRdy()`.

**OS\_CPU\_A.ASM** contains the assembly language functions to implement at least the following functions: `OSCtxSw()`, `OSIntCtxSw()` and `OSStartHighRdy()`.

**OS\_CPU\_C.C** contains the C code for the port specific hook functions and code to initialize the stack frame for a task when the task is created.

## 2-6 $\mu$ C/CPU, CPU SPECIFIC SOURCE CODE

$\mu$ C/CPU consists of files that encapsulate common CPU-specific functionality and CPU and compiler-specific data types. See Chapter 18, “Porting  $\mu$ C/OS-III” on page 335.

```
\Micrium
  \Software
    \uC-CPU
      \CPU_CORE.C
      \CPU_CORE.H
      \CPU_DEF.H
      \Cfg\Template
        \CPU_CFG.H
      \<architecture>
        \<compiler>
          \CPU.H
          \CPU_A.ASM
          \CPU_C.C
```

### **\Micrium**

Contains all software components and projects provided by Micrium.

### **\Software**

This sub-directory contains all software components and projects.

**\uC-CPU**

This is the main  $\mu$ C/CPU directory.

**CPU\_CORE.C** contains C code that is common to all CPU architectures. Specifically, this file contains functions to measure the interrupt disable time of the **CPU\_CRITICAL\_ENTER()** and **CPU\_CRITICAL\_EXIT()** macros, a function that emulates a count leading zeros instruction and a few other functions.

**CPU\_CORE.H** contains function prototypes for the functions provided in **CPU\_CORE.C** and allocation of the variables used by the module to measure interrupt disable time.

**CPU\_DEF.H** contains miscellaneous **#define** constants used by the  $\mu$ C/CPU module.

**\Cfg\Template**

This directory contains a configuration template file (**CPU\_CFG.H**) that must be copied to the application directory to configure the  $\mu$ C/CPU module based on application requirements.

**CPU\_CFG.H** determines whether to enable measurement of the interrupt disable time, whether the CPU implements a count leading zeros instruction in assembly language, or whether it will be emulated in C, and more.

**\<architecture>**

The name of the CPU architecture that  $\mu$ C/CPU was ported to. The “<” and “>” are not part of the actual name.

**\<compiler>**

The name of the compiler or compiler manufacturer used to build code for the  $\mu$ C/CPU port. The “<” and “>” are not part of the actual name.

The files in this directory contain the  $\mu$ C/CPU port, see Chapter 18, “Porting  $\mu$ C/OS-III” on page 335 for details on the contents of these files.

**CPU.H** contains type definitions to make  $\mu$ C/OS-III and other modules independent of the CPU and compiler word sizes. Specifically, one will find the declaration of the **CPU\_INT16U**, **CPU\_INT32U**, **CPU\_FP32** and many other data types. This file also specifies whether the CPU is a big or little endian machine, defines the **CPU\_STK** data type used by  $\mu$ C/OS-III, defines the macros **OS\_CRITICAL\_ENTER()** and **OS\_CRITICAL\_EXIT()**, and contains function prototypes for functions specific to the CPU architecture, and more.

**CPU\_A.ASM** contains the assembly language functions to implement code to disable and enable CPU interrupts, count leading zeros (if the CPU supports that instruction), and other CPU specific functions that can only be written in assembly language. This file may also contain code to enable caches, setup MPUs and MMU, and more. The functions provided in this file are accessible from C.

**CPU\_C.C** contains C code of functions that are based on a specific CPU architecture but written in C for portability. As a general rule, if a function can be written in C then it should be, unless there is significant performance benefits available by writing it in assembly language.

## 2-7 $\mu$ C/LIB, PORTABLE LIBRARY FUNCTIONS

$\mu$ C/LIB consists of library functions meant to be highly portable and not tied to any specific compiler. This facilitates third-party certification of Micrium products.  $\mu$ C/OS-III does not use any  $\mu$ C/LIB functions, however the  $\mu$ C/CPU assumes the presence of **LIB\_DEF.H** for such definitions as: **DEF\_YES**, **DEF\_NO**, **DEF\_TRUE**, **DEF\_FALSE**, **DEF\_ON**, **DEF\_OFF** and more.

```
\Micrium
  \Software
    \uC-LIB
      \LIB_ASCII.C
      \LIB_ASCII.H
      \LIB_DEF.H
      \LIB_MATH.C
      \LIB_MATH.H
      \LIB_MEM.C
      \LIB_MEM.H
      \LIB_STR.C
      \LIB_STR.H
      \Cfg\Template
        \LIB_CFG.H
      \Ports
        \<architecture>
          \<compiler>
            \LIB_MEM_A.ASM
```



**\Micrium**

Contains all software components and projects provided by Micrium.

**\Software**

This sub-directory contains all software components and projects.

**\uC-LIB**

This is the main  $\mu$ C/LIB directory.

**\Cfg\Template**

This directory contains a configuration template file (**LIB\_CFG.H**) that are required to be copied to the application directory to configure the  $\mu$ C/LIB module based on application requirements.

**LIB\_CFG.H** determines whether to enable assembly language optimization (assuming there is an assembly language file for the processor, i.e., **LIB\_MEM\_A.ASM**) and a few other **#defines**.

**2-8 SUMMARY**

Below is a summary of all directories and files involved in a  $\mu$ C/OS-III-based project. The “<-Cfg” on the far right indicates that these files are typically copied into the application (i.e., project) directory and edited based on the project requirements.

```

\Micrium
  \Software
    \EvalBoards
      \<manufacturer>
        \<board name>
          \<compiler>
            \<project name>
              \APP.C
              \APP.H
              \other
    \CPU
      \<manufacturer>
        \<architecture>
          \*.*
```

```
\uCOS-III
  \Cfg\Template
    \OS_APP_HOOKS.C
    \OS_CFG.H          <-Cfg
    \OS_CFG_APP.H     <-Cfg
  \Source
    \OS_CFG_APP.C
    \OS_CORE.C
    \OS_DBG.C
    \OS_FLAG.C
    \OS_INT.C
    \OS_MEM.C
    \OS_MSG.C
    \OS_MUTEX.C
    \OS_PEND_MULTI.C
    \OS_PRIO.C
    \OS_Q.C
    \OS_SEM.C
    \OS_STAT.C
    \OS_TASK.C
    \OS_TICK.C
    \OS_TIME.C
    \OS_TMR.C
    \OS_VAR.C
    \OS.H
    \OS_TYPE.H        <-Cfg
  \Ports
    <architecture>
      <compiler>
        \OS_CPU.H
        \OS_CPU_A.ASM
        \OS_CPU_C.C
  \uC-CPU
    \CPU_CORE.C
    \CPU_CORE.H
    \CPU_DEF.H
  \Cfg\Template
    \CPU_CFG.H        <-Cfg
```

```
\<architecture>
  \<compiler>
    \CPU.H
    \CPU_A.ASM
    \CPU_C.C
uC-LIB
  \LIB_ASCII.C
  \LIB_ASCII.H
  \LIB_DEF.H
  \LIB_MATH.C
  \LIB_MATH.H
  \LIB_MEM.C
  \LIB_MEM.H
  \LIB_STR.C
  \LIB_STR.H
  \Cfg\Template
    \LIB_CFG.H          <-Cfg
  \Ports
    \<architecture>
      \<compiler>
        \LIB_MEM_A.ASM
```



## Getting Started with $\mu$ C/OS-III

$\mu$ C/OS-III provides services to application code in the form of a set of functions that perform specific operations.  $\mu$ C/OS-III offers services to manage tasks, semaphores, message queues, mutual exclusion semaphores and more. As far as the application is concerned, it calls the  $\mu$ C/OS-III functions as if they were any other functions. In other words, the application now has access to a library of approximately 70 new functions.

In this chapter, the reader will appreciate how easy it is to start using  $\mu$ C/OS-III. Refer to Appendix A, “ $\mu$ C/OS-III API Reference Manual” on page 375, for the full description of several of the  $\mu$ C/OS-III services presented in this chapter.

It is assumed that the project setup (files and directories) is as described in the previous chapter, and that a C compiler exists for the target processor that is in use. However, this chapter makes no assumptions about the tools or the processor that is used.

## 3-1 SINGLE TASK APPLICATION

Listing 3-1 shows the top portion of a simple application file called `APP.C`.

```

/*
*****
*
*                               INCLUDE FILES
*
*****
*/
#include <app_cfg.h>                (1)
#include <bsp.h>
#include <os.h>
/*
*****
*
*                               LOCAL GLOBAL VARIABLES
*
*****
*/
static OS_TCB          AppTaskStartTCB;                (2)
static CPU_STK        AppTaskStartStk[APP_TASK_START_STK_SIZE]; (3)
/*
*****
*
*                               FUNCTION PROTOTYPES
*
*****
*/
static void AppTaskStart (void *p_arg);                (4)

```

Listing 3-1 **APP.C (1st Part)**

L3-1(1) As with any C programs, include the necessary headers to build the application.

`APP_CFG.H` is a header file that configures the application. For our example, `APP_CFG.H` contains `#define` constants to establish task priorities, stack sizes, and other application specifics.

`BSP.H` is the header file for the Board Support Package (BSP), which `defines` `#defines` and function prototypes, such as `BSP_Init()`, `BSP_LED_On()`, `OS_TS_GET()` and more.

`OS.H` is the main header file for  $\mu$ C/OS-III, and includes the following header files:

```
OS_CFG.H
CPU.H
CPU_CFG.H
CPU_CORE.H
OS_TYPE.H
OS_CPU.H
```

- L3-1(2) We will be creating an application task and it is necessary to allocate a task control block (`OS_TCB`) for this task.
- L3-1(3) Each task created requires its own stack. A stack must be declared using the `CPU_STK` data type. The stack can be allocated statically as shown here, or dynamically from the heap using `malloc()`. It should not be necessary to free the stack space, because the task should never be stopped, and the stack will always be used.
- L3-1(4) This is the function prototype of the task that we will create.

Most C applications start at `main()` as shown in Listing 3-2.

```

void main (void)
{
    OS_ERR err;

    BSP_IntDisAll();                (1)
    OSInit(&err);                    (2)
    if (err != OS_ERR_NONE) {
        /* Something didn't get initialized correctly ... */
        /* ... check OS.H for the meaning of the error code, see OS_ERR_xxxx */
    }
    OSTaskCreate((OS_TCB *)&AppTaskStartTCB,    (3)
                 (CPU_CHAR *)"App Task Start", (4)
                 (OS_TASK_PTR )AppTaskStart,    (5)
                 (void *)0,                    (6)
                 (OS_PRIO )APP_TASK_START_PRIO, (7)
                 (CPU_STK *)&AppTaskStartStk[0], (8)
                 (CPU_STK_SIZE)APP_TASK_START_STK_SIZE / 10, (9)
                 (CPU_STK_SIZE)APP_TASK_START_STK_SIZE, (10)
                 (OS_MSG_QTY )0,
                 (OS_TICK )0,
                 (void *)0,
                 (OS_OPT ) (OS_OPT_TASK_STK_CHK | OS_OPT_TASK_STK_CLR), (11)
                 (OS_ERR *)&err);             (12)
    if (err != OS_ERR_NONE) {
        /* The task didn't get created. Lookup the value of the error code ... */
        /* ... in OS.H for the meaning of the error */
    }
    OSStart(&err);                    (13)
    if (err != OS_ERR_NONE) {
        /* Your code is NEVER supposed to come back to this point. */
    }
}

```

Listing 3-2 APP.C (2nd Part)

- L3-2(1) Start `main()` by calling a BSP function that disables all interrupts. On most processors, interrupts are disabled at startup until explicitly enabled by application code. However, it is safer to turn off all peripheral interrupts during startup.
- L3-2(2) Call `OSInit()`, which is responsible for initializing  $\mu\text{C}/\text{OS-III}$ . `OSInit()` initializes internal variables and data structures, and also creates two (2) to five (5) internal tasks. At a minimum,  $\mu\text{C}/\text{OS-III}$  creates the idle task (`OS_IdleTask()`), which executes when no other task is ready to run.  $\mu\text{C}/\text{OS-III}$  also creates the tick task, which is responsible for keeping track of time.



---

Depending on the value of `#define` constants,  $\mu$ C/OS-III will create the statistic task (`OS_StatTask()`), the timer task (`OS_TmrTask()`), and the interrupt handler queue management task (`OS_IntQTask()`). Those are discussed in Chapter 5, “Task Management” on page 75.

Most of  $\mu$ C/OS-III’s functions return an error code via a pointer to an `OS_ERR` variable, `err` in this case. If `OSInit()` was successful, `err` will be set to `OS_ERR_NONE`. If `OSInit()` encounters a problem during initialization, it will return immediately upon detecting the problem and set `err` accordingly. If this occurs, look up the error code value in `OS.H`. Specifically, all error codes start with `OS_ERR_`.

It is important to note that `OSInit()` must be called before any other  $\mu$ C/OS-III function.

- L3-2(3) Create a task by calling `OSTaskCreate()`. `OSTaskCreate()` requires 13 arguments. The first argument is the address of the `OS_TCB` that is declared for this task. Chapter 5, “Task Management” on page 75 provides additional information about tasks.
- L3-2(4) `OSTaskCreate()` allows a name to be assigned to each of the tasks.  $\mu$ C/OS-III stores a pointer to the task name inside the `OS_TCB` of the task. There is no limit on the number of ASCII characters used for the name.
- L3-2(5) The third argument is the address of the task code. A typical  $\mu$ C/OS-III task is implemented as an infinite loop as shown:

```
void MyTask (void *p_arg)
{
    /* Do something with "p_arg".
    while (1) {
        /* Task body */
    }
}
```

The task receives an argument when it first starts. As far as the task is concerned, it looks like any other C function that can be called by the code. However, the code *must not* call `MyTask()`. The call is actually performed through  $\mu$ C/OS-III.

L3-2(6) The fourth argument of `OSTaskCreate()` is the actual argument that the task receives when it first begins. In other words, the “`p_arg`” of `MyTask()`. In the example a `NULL` pointer is passed, and thus “`p_arg`” for `AppTaskStart()` will be a `NULL` pointer.

The argument passed to the task can actually be any pointer. For example, the user may pass a pointer to a data structure containing parameters for the task.

L3-2(7) The next argument to `OSTaskCreate()` is the priority of the task. The priority establishes the relative importance of this task with respect to the other tasks in the application. A low-priority number indicates a high priority (or more important task). Set the priority of the task to any value between 1 and `OS_CFG_PRIO_MAX-2`, inclusively. Avoid using priority #0, and priority `OS_CFG_PRIO_MAX-1`, because these are reserved for  $\mu\text{C}/\text{OS-III}$ . `OS_CFG_PRIO_MAX` is a compile time configuration constant, which is declared in `OS_CFG.H`.

L3-2(8) The sixth argument to `OSTaskCreate()` is the base address of the stack assigned to this task. The base address is always the lowest memory location of the stack.

L3-2(9) The next argument specifies the location of a “watermark” in the task’s stack that can be used to determine the allowable stack growth of the task. See Chapter 5, “Task Management” on page 75 for more details on using this feature. In the code above, the value represents the amount of stack space (in `CPU_STK` elements) before the stack is empty. In other words, in the example, the limit is reached when there is 10% of the stack left.

L3-2(10) The eighth argument to `OSTaskCreate()` specifies the size of the task’s stack in number of `CPU_STK` elements (not bytes). For example, if allocating 1 Kbyte of stack space for a task and the `CPU_STK` is a 32-bit word, then pass 256.

L3-2(11) The next three arguments are skipped as they are not relevant for the current discussion. The next argument to `OSTaskCreate()` specifies options. In this example, we specify that the stack will be checked at run time (assuming the statistic task was enabled in `OS_CFG.H`), and that the contents of the stack will be cleared when the task is created.

- L3-2(12) The last argument of `OSTaskCreate()` is a pointer to a variable that will receive an error code. If `OSTaskCreate()` is successful, the error code will be `OS_ERR_NONE` otherwise, look up the value of the error code in `OS.H` (See `OS_ERR_XXXX`) to determine the problem with the call.
- L3-2(13) The final step in `main()` is to call `OSStart()`, which starts the multitasking process. Specifically,  $\mu$ C/OS-III will select the highest-priority task that was created before calling `OSStart()`. The highest-priority task is always `OS_IntQTask()` if that task is enabled in `OS_CFG.H` (through the `OS_CFG_ISR_POST_DEFERRED_EN` constant). If this is the case, `OS_IntQTask()` will perform some initialization of its own and then  $\mu$ C/OS-III will switch to the next most important task that was created.

A few important points are worth noting. For one thing, create as many tasks as you want before calling `OSStart()`. However, it is recommended to only create one task as shown in the example because, having a single application task allows  $\mu$ C/OS-III to determine how fast the CPU is, in order to determine the percentage of CPU usage at run-time. Also, if the application needs other kernel objects such as semaphores and message queues then it is recommended that these be created prior to calling `OSStart()`. Finally, notice that that interrupts are not enabled. This will be discussed next by examining the contents of `AppTaskStart()`, which is shown in Listing 3-3.

```

static void AppTaskStart (void *p_arg)                (1)
{
    OS_ERR err;

    p_arg = p_arg;
    BSP_Init();                                     (2)
    CPU_Init();                                     (3)
    BSP_Cfg_Tick();                                 (4)
    BSP_LED_Off(0);                                 (5)
    while (1) {                                     (6)
        BSP_LED_Toggle(0);                          (7)
        OSTimeDlyHMSM((CPU_INT16U) 0,              (8)
                      (CPU_INT16U) 0,
                      (CPU_INT16U) 0,
                      (CPU_INT32U)100,
                      (OS_OPT   )OS_OPT_TIME_HMSM_STRICT,
                      (OS_ERR   *)&err);
        /* Check for 'err' */
    }
}

```

Listing 3-3 APP.C (3rd Part)

- L3-3(1) As previously mentioned, a task looks like any other C function. The argument “p\_arg” is passed to `AppTaskStart()` by `OSTaskCreate()`, as discussed in the previous listing description.
- L3-3(2) `BSP_Init()` is a Board Support Package (BSP) function that is responsible for initializing the hardware on an evaluation or target board. The evaluation board might have General Purpose Input Output (GPIO) lines that might need to be configured, relays, sensors and more. This function is found in a file called `BSP.C`.
- L3-3(3) `CPU_Init()` initializes the  $\mu$ C/CPU services.  $\mu$ C/CPU provides services to measure interrupt latency, receive time stamps, and provides emulation of the count leading zeros instruction if the processor used does not have that instruction and more.
- L3-3(4) `BSP_Cfg_Tick()` sets up the  $\mu$ C/OS-III tick interrupt. For this, the function needs to initialize one of the hardware timers to interrupt the CPU at a rate of: `OS_Cfg_TickRate_Hz`, which is defined in `OS_CFG_APP.H` (See `OS_CFG_TICK_RATE_HZ`).

- L3-3(5)     **BSP\_LED\_Off()** is a function that will turn off all LEDs because the function is written so that a zero argument means all the LEDs.
- L3-3(6)     Most  $\mu$ C/OS-III tasks will need to be written as an infinite loop.
- L3-3(7)     This BSP function toggles the state of the specified LED. Again, a zero indicates that all the LEDs should be toggled on the evaluation board. Simply change the zero to 1 and this will cause LED #1 to toggle. Exactly which LED is LED #1? That depends on the BSP developer. Specifically, encapsulate access to LEDs through such functions as **BSP\_LED\_On()**, **BSP\_LED\_Off()** and **BSP\_LED\_Toggle()**. Also, we prefer to assign LEDs logical values (1, 2, 3, etc.) instead of specifying which port and which bit on each port.
- L3-3(8)     Finally, each task in the application must call one of the  $\mu$ C/OS-III functions that will cause the task to “wait for an event.” The task can wait for time to expire (by calling **OSTimeDly()**, or **OSTimeDlyHMSM()**), or wait for a signal or a message from an ISR or another task. Chapter 11, “Time Management” on page 183 provides additional information about time delays.

## 3-2 MULTIPLE TASKS APPLICATION WITH KERNEL OBJECTS

The code of Listing 3-4 through Listing 3-8 shows a more complete example and contains three tasks: a mutual exclusion, semaphore, and a message queue.

```
/*
*****
*
*                               INCLUDE FILES
*
*****
*/
#include <app_cfg.h>
#include <bsp.h>
#include <os.h>
/*
*****
*
*                               LOCAL GLOBAL VARIABLES
*
*****
*/
static OS_TCB      AppTaskStartTCB;           (1)
static OS_TCB      AppTask1_TCB;
static OS_TCB      AppTask2_TCB;
static OS_MUTEX    AppMutex;                 (2)
static OS_Q         AppQ;                     (3)
static CPU_STK     AppTaskStartStk[APP_TASK_START_STK_SIZE]; (4)
static CPU_STK     AppTask1_Stk[128];
static CPU_STK     AppTask2_Stk[128];
/*
*****
*
*                               FUNCTION PROTOTYPES
*
*****
*/
static void AppTaskStart (void *p_arg);       (5)
static void AppTask1     (void *p_arg);
static void AppTask2     (void *p_arg);
```

Listing 3-4 APP.C (1st Part)

- L3-4(1) Allocate storage for the `OS_TCBs` of each task.
- L3-4(2) A mutual exclusion semaphore (a.k.a. a mutex) is a kernel object (a data structure) that is used to protect a shared resource from being accessed by more than one task. A task that wants to access the shared resource must obtain the mutex before it is allowed to proceed. The owner of the resource relinquishes the mutex when it has finished accessing the resource. This process is demonstrated in this example.
- L3-4(3) A message queue is a kernel object through which Interrupt Service Routines (ISRs) and/or tasks send messages to other tasks. The sender “formulates” a message and sends it to the message queue. The task(s) wanting to receive these messages wait on the message queue for messages to arrive. If there are already messages in the message queue, the receiver immediately retrieves those messages. If there are no messages waiting in the message queue, then the receiver will be placed in a wait list associated with the message queue. This process will be demonstrated in this example.
- L3-4(4) Allocate a stack for each task.
- L3-4(5) The user must prototype the tasks.

Listing 3-5 shows the entry point for C, `main()`.

```
void main (void)
{
    OS_ERR err;

    BSP_IntDisAll();
    OSInit(&err);
    /* Check for 'err' */

    OSMutexCreate((OS_MUTEX *)&AppMutex,                (1)
                  (CPU_CHAR *)"My App. Mutex",
                  (OS_ERR *)&err);
    /* Check for 'err' */

    OSQCreate ((OS_Q *)&AppQ,                            (2)
              (CPU_CHAR *)"My App Queue",
              (OS_MSG_QTY )10,
              (OS_ERR *)&err);
    /* Check for 'err' */

    OSTaskCreate((OS_TCB *)&AppTaskStartTCB,            (3)
                (CPU_CHAR *)"App Task Start",
                (OS_TASK_PTR )AppTaskStart,
                (void *)0,
                (OS_PRIO )APP_TASK_START_PRIO,
                (CPU_STK *)&AppTaskStartStk[0],
                (CPU_STK_SIZE)APP_TASK_START_STK_SIZE / 10,
                (CPU_STK_SIZE)APP_TASK_START_STK_SIZE,
                (OS_MSG_QTY )0,
                (OS_TICK )0,
                (void *)0,
                (OS_OPT )(OS_OPT_TASK_STK_CHK | OS_OPT_TASK_STK_CLR),
                (OS_ERR *)&err);
    /* Check for 'err' */

    OSStart(&err);
    /* Check for 'err' */
}
```

Listing 3-5 APP.C (2nd Part)



L3-5(1) Creating a mutex is simply a matter of calling `OSMutexCreate()`. Specify the address of the `OS_MUTEX` object that will be used for the mutex. Chapter 13, “Resource Management” on page 209 provides additional information about mutual exclusion semaphores.

You can assign an ASCII name to the mutex, which is useful when debugging.

L3-5(2) Create the message queue by calling `OSQCreate()` and specifying the address of the `OS_Q` object. Chapter 15, “Message Passing” on page 289 provides additional information about message queues.

Assign an ASCII name to the message queue.

Specify how many messages the message queue is allowed to receive. This value must be greater than zero. If the sender sends messages faster than they can be consumed by the receiving task, messages will be lost. This can be corrected by either increasing the size of the message queue, or increasing the priority of the receiving task.

L3-5(3) The first application task is created.

Listing 3-6 shows how to create other tasks once multitasking is started.

```

static void AppTaskStart (void *p_arg)
{
    OS_ERR err;

    p_arg = p_arg;
    BSP_Init();
    CPU_Init();
    BSP_Cfg_Tick();
    OSTaskCreate((OS_TCB *) &AppTask1_TCB, (1)
                (CPU_CHAR *) "App Task 1",
                (OS_TASK_PTR) AppTask1,
                (void *) 0,
                (OS_PRIO) 5,
                (CPU_STK *) &AppTask1_Stk[0],
                (CPU_STK_SIZE) 0,
                (CPU_STK_SIZE) 128,
                (OS_MSG_QTY) 0,
                (OS_TICK) 0,
                (void *) 0,
                (OS_OPT) (OS_OPT_TASK_STK_CHK | OS_OPT_TASK_STK_CLR),
                (OS_ERR *) &err);

    OSTaskCreate((OS_TCB *) &AppTask2_TCB, (2)
                (CPU_CHAR *) "App Task 2",
                (OS_TASK_PTR) AppTask2,
                (void *) 0,
                (OS_PRIO) 6,
                (CPU_STK *) &AppTask2_Stk[0],
                (CPU_STK_SIZE) 0,
                (CPU_STK_SIZE) 128,
                (OS_MSG_QTY) 0,
                (OS_TICK) 0,
                (void *) 0,
                (OS_OPT) (OS_OPT_TASK_STK_CHK | OS_OPT_TASK_STK_CLR),
                (OS_ERR *) &err);

    BSP_LED_Off(0);
    while (1) {
        BSP_LED_Toggle(0);
        OSTimeDlyHMSM((CPU_INT16U) 0,
                      (CPU_INT16U) 0,
                      (CPU_INT16U) 0,
                      (CPU_INT32U) 100,
                      (OS_OPT) OS_OPT_TIME_HMSM_STRICT,
                      (OS_ERR *) &err);
    }
}

```

Listing 3-6 APP.C (3rd Part)

- L3-6(1) Create Task #1 by calling `OSTaskCreate()`. If this task happens to have a higher priority than the task that creates it,  $\mu$ C/OS-III will immediately start Task #1. If the created task has a lower priority, `OSTaskCreate()` will return to `AppTaskStart()` and continue execution.
- L3-6(2) Task #2 is created and if it has a higher priority than `AppTaskStart()`,  $\mu$ C/OS-III will immediately switch to that task.

```

static void AppTask1 (void *p_arg)
{
    OS_ERR  err;
    CPU_TS  ts;

    p_arg = p_arg;
    while (1) {
        OSTimeDly ((OS_TICK      )1,                               (1)
                  (OS_OPT      )OS_OPT_TIME_DLY,
                  (OS_ERR      *)&err);
        OSQPost  ((OS_Q        *)&AppQ,                          (2)
                  (void        *)1;
                  (OS_MSG_SIZE)sizeof(void *),
                  (OS_OPT      )OS_OPT_POST_FIFO,
                  (OS_ERR      *)&err);
        OSMutexPend((OS_MUTEX   *)&AppMutex,                    (3)
                   (OS_TICK     )0,
                   (OS_OPT      )OS_OPT_PEND_BLOCKING;
                   (CPU_TS      *)&ts,
                   (OS_ERR      *)&err);
        /* Access shared resource */                               (4)
        OSMutexPost((OS_MUTEX   *)&AppMutex,                    (5)
                   (OS_OPT      )OS_OPT_POST_NONE,
                   (OS_ERR      *)&err);
    }
}

```

Listing 3-7 APP.C (4th Part)

- L3-7(1) The task starts by waiting for one tick to expire before it does anything useful. If the  $\mu$ C/OS-III tick rate is configured for 1000 Hz, the task will execute every millisecond.

- L3-7(2)     The task then sends a message to another task using the message queue AppQ. In this case, the example shows a fixed message “1,” but the message could have consisted of the address of a buffer, the address of a function, or whatever would need to be sent.
  
- L3-7(3)     The task then waits on the mutual exclusion semaphore since it needs to access a shared resource with another task. If the resource is already owned by another task, `AppTask1()` will wait forever for the mutex to be released by its current owner. The forever wait is specified by passing 0 as the second argument of the call.
  
- L3-7(4)     When `OSMutexPend()` returns, the task owns the resource and can therefore access the shared resource. The shared resource may be a variable, an array, a data structure, an I/O device, etc.
  
- L3-7(5)     When the task is done with the shared resource, it must call `OSMutexPost()` to release the mutex.

```

static void AppTask2 (void *p_arg)
{
    OS_ERR      err;
    void        *p_msg;
    OS_MSG_SIZE msg_size;
    CPU_TS      ts;
    CPU_TS      ts_delta;

    p_arg = p_arg;
    while (1) {
        p_msg = OSQPend((OS_Q      *) &AppQ,           (1)
                       (OS_MSG_SIZE *) &msg_size,
                       (OS_TICK    ) 0,
                       (OS_OPT     ) OS_OPT_PEND_BLOCKING,
                       (CPU_TS     *) &ts,
                       (OS_ERR     *) &err);
        ts_delta = OS_TS_GET() - ts;                (2)
        /* Process message received */              (3)
    }
}

```

Listing 3-8 APP.C (5th Part)

L3-8(1) Task #2 starts by waiting for messages to be sent through the message queue AppQ. The task waits forever for a message to be received because the third argument specifies an infinite timeout.

When the message is received `p_msg` will contain the message (i.e., a pointer to “something”). Both the sender and receiver must agree as to the meaning of the message. The size of the message received is saved in “`msg_size`”. Note that “`p_msg`” could point to a buffer and “`msg_size`” would indicate the size of this buffer.

Also, when the message is received, “`ts`” will contain the timestamp of when the message was sent. A timestamp is the value read from a fairly fast free-running timer. The timestamp is typically an unsigned 32-bit (or more) value.

L3-8(2) Knowing when the message was sent allows the user to determine how long it took this task to get the message. Reading the current timestamp and subtracting the timestamp of when the message was sent allows users to know how long it took for the message to be received. Note that the receiving task may not get the message immediately since ISRs or other higher-priority tasks might execute before the receiver gets to run.

L3-8(3) Proceed with processing the received message.



## Critical Sections

A critical section of code, also called a *critical region*, is code that needs to be treated indivisibly. There are many critical sections of code contained in  $\mu\text{C}/\text{OS-III}$ . If a critical section is accessible by an Interrupt Service Routine (ISR) and a task, then disabling interrupts is necessary to protect the critical region. If the critical section is only accessible by task level code, the critical section may be protected through the use of a *preemption lock*.

Within  $\mu\text{C}/\text{OS-III}$ , the critical section access method depends on which ISR post method is used by interrupts (see Chapter 9, “Interrupt Management” on page 157). If `OS_CFG_ISR_POST_DEFERRED_EN` is set to 0 (see `OS_CFG.H`) then  $\mu\text{C}/\text{OS-III}$  will disable interrupts when accessing internal critical sections. If `OS_CFG_ISR_POST_DEFERRED_EN` is set to 1 then  $\mu\text{C}/\text{OS-III}$  will lock the scheduler when accessing most of its internal critical sections.

Chapter 9, “Interrupt Management” on page 157 discusses how to select the method to use.

$\mu\text{C}/\text{OS-III}$  defines one macro for entering a critical section and two macros for leaving:

```
OS_CRITICAL_ENTER(),  
OS_CRITICAL_EXIT() and  
OS_CRITICAL_EXIT_NO_SCHED()
```

These macros are internal to  $\mu\text{C}/\text{OS-III}$  and must not be invoked by the application code. However, if you need to access critical sections in your application code, consult Chapter 13, “Resource Management” on page 209.

## 4-1 DISABLING INTERRUPTS

When setting `OS_CFG_ISR_POST_DEFERRED_EN` to 0,  $\mu\text{C}/\text{OS-III}$  will disable interrupts before entering a critical section and re-enable them when leaving the critical section.

`OS_CRITICAL_ENTER()` invokes the  $\mu\text{C}/\text{CPU}$  macro `CPU_CRITICAL_ENTER()` that, in turn, calls `CPU_SR_Save()`. `CPU_SR_Save()` is a function typically written in assembly language that saves the current interrupt disable status and then disables interrupts. The saved interrupt disable status is returned to the caller and in fact, it is stored onto the caller's stack in a variable called "cpu\_sr".

`OS_CRITICAL_EXIT()` and `OS_CRITICAL_EXIT_NO_SCHED()` both invoke the  $\mu\text{C}/\text{CPU}$  macro `CPU_CRITICAL_EXIT()`, which maps to `CPU_SR_Restore()`. `CPU_SR_Restore()` is passed the value of the saved "cpu\_sr" variable to re-establish interrupts the way they were prior to calling `OS_CRITICAL_ENTER()`.

The typical code for the macros is shown in Listing 4-1.

```
#define OS_CRITICAL_ENTER()      { CPU_CRITICAL_ENTER(); }
#define OS_CRITICAL_EXIT()      { CPU_CRITICAL_EXIT(); }
#define OS_CRITICAL_EXIT_NO_SCHED() { CPU_CRITICAL_EXIT(); }
```

Listing 4-1 Critical section code – Disabling interrupts

### 4-1-1 MEASURING INTERRUPT DISABLE TIME

$\mu\text{C}/\text{CPU}$  provides facilities to measure the amount of time interrupts are disabled. This is done by setting the configuration constant `CPU_CFG_TIME_MEAS_INT_DIS_EN` to 1 in `CPU_CFG.H`.

The measurement is started each time interrupts are disabled and ends when interrupts are re-enabled. The measurement keeps track of two values: a global interrupt disable time, and an interrupt disable time for each task. Therefore, it is possible to know how long a task disables interrupts, enabling the user to better optimize their code.

The per-task interrupt disable time is saved in the task's `OS_TCB` during a context switch (see `OSTaskSwHook()` in `OS_CPU_C.C` and described in Chapter 8, "Context Switching" on page 147).



The unit of measure for the measured time is in CPU\_TS (timestamp) units. It is necessary to find out the resolution of the timer used to measure these timestamps. For example, if the timer used for the timestamp is incremented at 1 MHz then the resolution of CPU\_TS is 1 microsecond.

Measuring the interrupt disable time obviously adds measurement artifacts and thus increases the amount of time the interrupts are disabled. However, as far as the measurement is concerned, measurement overhead is accounted for and the measured value represents the actual interrupt disable time as if the measurement was not present.

Interrupt disable time is obviously greatly affected by the speed at which the processor accesses instructions and thus, the memory access speed. In this case, the hardware designer might have introduced wait states to memory accesses, which affects overall performance of the system. This may show up as unusually long interrupt disable times.

## **4-2 LOCKING THE SCHEDULER**

When setting OS\_CFG\_ISR\_POST\_DEFERRED\_EN to 1,  $\mu$ C/OS-III locks the scheduler before entering a critical section and unlocks the scheduler when leaving the critical section.

OS\_CRITICAL\_ENTER() simply increments OSSchedLockNestingCtr to lock the scheduler. This is the variable the scheduler uses to determine whether or not the scheduler is locked. It is locked when the value is non-zero.

OS\_CRITICAL\_EXIT() decrements OSSchedLockNestingCtr and when the value reaches zero, invokes the scheduler.

OS\_CRITICAL\_EXIT\_NO\_SCHED() also decrements OSSchedLockNestingCtr, but does not invoke the scheduler when the value reaches zero.

The code for the macros is shown in Listing 4-2.

```

#define OS_CRITICAL_ENTER()      {                               \
                                CPU_CRITICAL_ENTER();           \
                                OSSchedLockNestingCtr++;        \
                                CPU_CRITICAL_EXIT();             \
                                }
#define OS_CRITICAL_EXIT()      {                               \
                                CPU_CRITICAL_ENTER();           \
                                OSSchedLockNestingCtr--;        \
                                if (OSSchedLockNestingCtr == (OS_NESTING_CTR)0) { \
                                    CPU_CRITICAL_EXIT();         \
                                    OSSched();                  \
                                } else {                          \
                                    CPU_CRITICAL_EXIT();         \
                                }                                 \
                                }
#define OS_CRITICAL_EXIT_NO_SCHED() { \
                                CPU_CRITICAL_ENTER();           \
                                OSSchedLockNestingCtr--;        \
                                CPU_CRITICAL_EXIT();             \
                                }

```

Listing 4-2 Critical section code – Locking the Scheduler

## 4-2-1 MEASURING SCHEDULER LOCK TIME

µC/OS-III provides facilities to measure the amount of time the scheduler is locked. This is done by setting the configuration constant `OS_CFG_SCHED_LOCK_TIME_MEAS_EN` to 1 in `OS_CFG.H`.

The measurement is started each time the scheduler is locked and ends when the scheduler is unlocked. The measurement keeps track of two values: a global scheduler lock time, and a per-task scheduler lock time. It is therefore possible to know how long each task locks the scheduler allowing the user to better optimize code.

The per-task scheduler lock time is saved in the task's `OS_TCB` during a context switch (see `OSTaskSwHook()` in `OS_CPU_C.C` and described in Chapter 8, “Context Switching” on page 147).

The unit of measure for the measured time is in `CPU_TS` (timestamp) units so it is necessary to find the resolution of the timer used to measure the timestamps. For example, if the timer used for the timestamp is incremented at 1 MHz then the resolution of `CPU_TS` is 1 microsecond.

Measuring the scheduler lock time adds measurement artifacts and thus increases the amount of time the scheduler is actually locked. However, measurement overhead is accounted for and the measured value represents the actual scheduler lock time as if the measurement was not present.

### 4-3 $\mu$ C/OS-III FEATURES WITH LONGER CRITICAL SECTIONS

Table 4-1 shows several  $\mu$ C/OS-III features that have potentially longer critical sections. Knowledge of these will help the user decide whether to direct  $\mu$ C/OS-III to use one critical section over another.

| Feature   | Reason   |
|---|--|
| <b>Multiple tasks at the same priority</b>  | Although this is an important feature of $\mu$ C/OS-III, multiple tasks at the same priority create longer critical sections. However, if there are only a few tasks at the same priority, interrupt latency would be relatively small. If multiple tasks are not created at the same priority, use the interrupt disable method.  |
| <b>Event Flags</b><br>Chapter 14, "Synchronization" on page 251   | If multiple tasks are waiting on different events, going through all of the tasks waiting for events requires a fair amount of processing time, which means longer critical sections. If only a few tasks (approximately one to five) are waiting on an event flag group, the critical section would be short enough to use the interrupt disable method.  |
| <b>Pend on multiple objects</b><br>Chapter 16, "Pending On Multiple Objects" on page 313  | Pending on multiple objects is probably the most complex feature provided by $\mu$ C/OS-III, requiring interrupts to be disabled for fairly long periods of time should the interrupt disable method be selected. If pending on multiple objects, it is highly recommended that the user select the scheduler-lock method. If the application does not use this feature, the interrupt disable method is an alternative. |
| <b>Broadcast on Post calls</b><br>See <code>OSSemPost()</code> and <code>OSQPost()</code> descriptions in Appendix A, " $\mu$ C/OS-III API Reference Manual" on page 375. | $\mu$ C/OS-III disables interrupts while processing a post to multiple tasks in a broadcast. When not using the broadcast option, you can use the interrupt disable method.  |

Table 4-1 Disabling interrupts or locking the Scheduler

## 4-4 SUMMARY

$\mu$ C/OS-III needs to access critical sections of code, which it protects by either disabling interrupts (`OS_CFG_ISR_POST_DEFERRED_EN` set to 0 in `OS_CFG.H`), or locking the scheduler (`OS_CFG_ISR_POST_DEFERRED_EN` set to 1 in `OS_CFG.H`).

The application code must not use:

```
OS_CRITICAL_ENTER()  
OS_CRITICAL_EXIT()  
OS_CRITICAL_EXIT_NO_SCHED()
```

When setting `CPU_CFG_TIME_MEAS_INT_DIS_EN` in `CPU_CFG.H`,  $\mu$ C/CPU measures the maximum interrupt disable time. There are two values available, one for the global maximum and one for each task.

When setting `OS_CFG_SCHED_LOCK_TIME_MEAS_EN` to 1 in `OS_CFG.H`,  $\mu$ C/OS-III will measure the maximum scheduler lock time.

## Task Management

The design process of a real-time application generally involves splitting the work to be completed into tasks, each responsible for a portion of the problem.  $\mu$ C/OS-III makes it easy for an application programmer to adopt this paradigm. A task (also called a *thread*) is a simple program that thinks it has the Central Processing Unit (CPU) all to itself. On a single CPU, only one task can execute at any given time.

$\mu$ C/OS-III supports multitasking and allows the application to have any number of tasks. The maximum number of task is actually only limited by the amount of memory (both code and data space) available to the processor. Multitasking is the process of *scheduling* and *switching* the CPU between several tasks (this will be expanded upon later). The CPU switches its attention between several *sequential* tasks. Multitasking provides the illusion of having multiple CPUs and, actually maximizes the use of the CPU. Multitasking also helps in the creation of modular applications. One of the most important aspects of multitasking is that it allows the application programmer to manage the complexity inherent in real-time applications. Application programs are typically easier to design and maintain when multitasking is used.

Tasks are used for such chores as monitoring inputs, updating outputs, performing computations, control loops, update one or more displays, reading buttons and keyboards, communicating with other systems, and more. One application may contain a handful of tasks while another application may require hundreds. The number of tasks does not establish how good or effective a design may be, it really depends on what the application (or product) needs to do. The amount of work a task performs also depends on the application. One task may have a few microseconds worth of work to perform while another task may require tens of milliseconds.

Tasks look like just any other C function except for a few small differences. There are two types of tasks: run-to-completion (Listing 5-1) and infinite loop (Listing 5-2). In most embedded systems, tasks typically take the form of an infinite loop. Also, no task is allowed to return as other C functions can. Given that a task is a regular C function, it can declare local variables.

When a  $\mu\text{C}/\text{OS-III}$  task begins executing, it is passed an argument, `p_arg`. This argument is a pointer to a `void`. The pointer is a universal vehicle used to pass your task the address of a variable, a structure, or even the address of a function, if necessary. With this pointer, it is possible to create many identical tasks, that all use the same code (or task body), but, with different run-time characteristics. For example, one may have four asynchronous serial ports that are each managed by their own task. However, the task code is actually identical. Instead of copying the code four times, create the code for a “generic” task that receives a pointer to a data structure, which contains the serial port’s parameters (baud rate, I/O port addresses, interrupt vector number, etc.) as an argument. In other words, instantiate the same task code four times and pass it different data for each serial port that each instance will manage.

A run-to-completion task must *delete* itself by calling `OSTaskDel()`. The task starts, performs its function, and terminates. There would typically not be too many such tasks in the embedded system because of the overhead associated with “creating” and “deleting” tasks at run-time. In the task body, one can call most of  $\mu\text{C}/\text{OS-III}$ ’s functions to help perform the desired operation of the task.

```
void MyTask (void *p_arg)
{
    OS_ERR  err;
    /* Local variables                                     */

    /* Do something with 'p_arg'                           */
    /* Task initialization                                  */
    /* Task body ... do work!                              */
    OSTaskDel((OS_TCB *)0, &err);
}
```

Listing 5-1 **Run-To-Completion task**

With  $\mu\text{C}/\text{OS-III}$ , call either C or assembly language functions from a task. In fact, it is possible to call the same C function from different tasks as long as the functions are reentrant. A *reentrant* function is a function that does not use static or otherwise global variables unless they are protected ( $\mu\text{C}/\text{OS-III}$  provides mechanisms for this) from multiple access. If shared C functions only use local variables, they are generally reentrant (assuming that the compiler generates reentrant code). An example of a non-reentrant function is the famous `strtok()` provided by most C compilers as part of the standard library. This function is used to parse an ASCII string for “tokens.” The first time you call this function, you specify

the ASCII string to parse and what constitute tokens. As soon as the function finds the first token, it returns. The function “remembers” where it was last so when called again, it can extract additional tokens, which is clearly non-reentrant.

The use of an infinite loop is more common in embedded systems because of the repetitive work needed in such systems (reading inputs, updating displays, performing control operations, etc.). This is one aspect that makes a task different than a regular C function. Note that one could use a “`while (1)`” or “`for (;;)` ” to implement the infinite loop, since both behave the same. The one used is simply a matter of personal preference. At Micrium, we like to use “`while (DEF_ON)`”. The infinite loop **must** call a  $\mu$ C/OS-III service (i.e., function) that will cause the task to wait for an event to occur. It is important that each task wait for an event to occur, otherwise the task would be a true infinite loop and there would be no easy way for other tasks to execute. This concept will become clear as more is understood regarding  $\mu$ C/OS-III.

```
void MyTask (void *p_arg)
{
    /* Local variables                                     */

    /* Do something with "p_arg"                         */
    /* Task initialization                                */
    while (DEF_ON) { /* Task body, as an infinite loop. */
        :
        /* Task body ... do work!                        */
        :
        /* Must call one of the following services:      */
        /* OSFlagPend()                                 */
        /* OSMutexPend()                               */
        /* OSPendMulti()                               */
        /* OSQPend()                                   */
        /* OSSemPend()                                 */
        /* OSTimeDly()                                 */
        /* OSTimeDlyHMSM()                             */
        /* OSTaskQPend()                               */
        /* OSTaskSemPend()                             */
        /* OSTaskSuspend() (Suspend self)              */
        /* OSTaskDel() (Delete self)                  */
        :
        /* Task body ... do work!                        */
        :
    }
}
```

Listing 5-2 Infinite Loop task

The event the task is waiting for may simply be the passage of time (when `OSTimeDly()` or `OSTimeDlyHMSM()` is called). For example, a design may need to scan a keyboard every 100 milliseconds. In this case, simply delay the task for 100 milliseconds then see if a key was pressed on the keyboard and, possibly perform some action based on which key was pressed. Typically, however, a keyboard scanning task should just buffer an “identifier” unique to the key pressed and use another task to decide what to do with the key(s) pressed.

Similarly, the event the task is waiting for could be the arrival of a packet from an Ethernet controller. In this case, the task would call one of the `OS???Pend()` calls (pend is synonymous with wait). The task will have nothing to do until the packet is received. Once the packet is received, the task processes the contents of the packet, and possibly moves the packet along a network stack.

It’s important to note that when a task waits for an event, it does not consume CPU time.

Tasks must be created in order for  $\mu$ C/OS-III to know about tasks. Create a task by simply calling `OSTaskCreate()`. The function prototype for `OSTaskCreate()` is shown below:

```
void OSTaskCreate (OS_TCB      *p_tcb,
                  OS_CHAR      *p_name,
                  OS_TASK_PTR  p_task,
                  void         *p_arg,
                  OS_PRIO      prio,
                  CPU_STK      *p_stk_base,
                  CPU_STK_SIZE stk_limit,
                  CPU_STK_SIZE stk_size,
                  OS_MSG_QTY   q_size,
                  OS_TICK      time_slice,
                  void         *p_ext,
                  OS_OPT        opt,
                  OS_ERR        *p_err)
```

A complete description of `OSTaskCreate()` and its arguments is provided in Appendix A, “ $\mu$ C/OS-III API Reference Manual” on page 375. However, it is important to understand that a task needs to be assigned a *Task Control Block* (i.e., TCB), a stack, a priority and a few other parameters which are initialized by `OSTaskCreate()`, as shown in Figure 5-1.



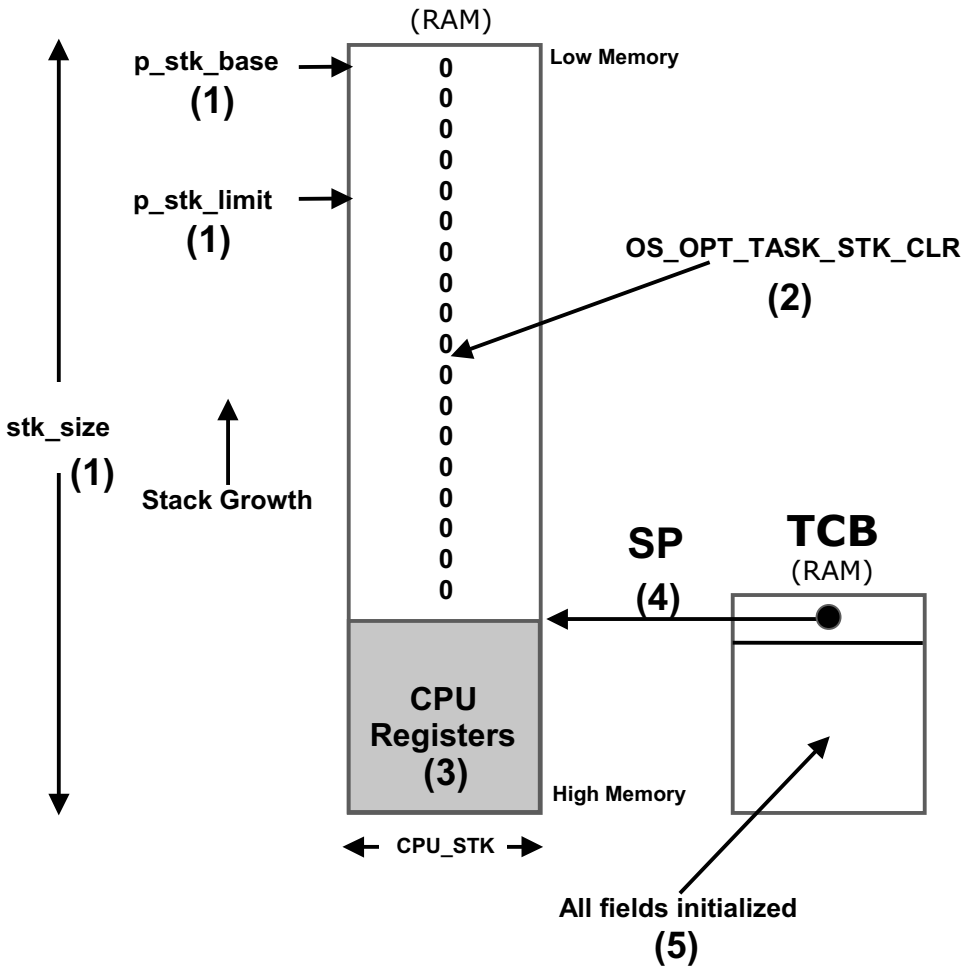

Figure 5-1 OSTaskCreate() initializes the task's TCB and stack

F5-1(1) When calling OSTaskCreate(), one passes the base address of the stack (**p\_stk\_base**) that will be used by the task, the watermark limit for stack growth (**stk\_limit**) which is expressed in number of **CPU\_STK** entries before the stack is empty, and the size of that stack (**stk\_size**), also in number of **CPU\_STK** elements.

F5-1(2) When specifying **OS\_OPT\_TASK\_STK\_CHK + OS\_OPT\_TASK\_STK\_CLR** in the opt argument of OSTaskCreate(),  $\mu$ C/OS-III initializes the task's stack with all zeros.

- F5-1(3)  $\mu$ C/OS-III then initializes the top of the task's stack with a copy of the CPU registers in the same stacking order as if they were all saved at the beginning of an ISR. This makes it easy to perform context switches as we will see when discussing the context switching process. For illustration purposes, the assumption is that the stack grows from high memory to low memory, but the same concept applies for CPUs that use the stack in the reverse order.
- F5-1(4) The new value of the stack pointer (SP) is saved in the TCB. Note that this is also called the **top-of-stack**.
- F5-1(5) The remaining fields of the TCB are initialized: task priority, task name, task state, internal message queue, internal semaphore, and many others.

Next, a call is made to a function that is defined in the CPU port, `OSTaskCreateHook()` (see `OS_CPU_C.C`). `OSTaskCreateHook()` is passed the pointer to the new TCB and this function allows you (or the port designer) to extend the functionality of `OSTaskCreate()`. For example, one could printout the contents of the fields of the newly created TCB onto a terminal for debugging purposes.

The task is then placed in the ready-list (see Chapter 6, "The Ready List" on page 123) and finally, if multitasking has started,  $\mu$ C/OS-III will invoke the scheduler to see if the created task is now the highest priority task and, if so, will context switch to this new task.

The body of the task can invoke other services provided by  $\mu$ C/OS-III. Specifically, a task can create another task (i.e., call `OSTaskCreate()`), suspend and resume other tasks (i.e., call `OSTaskSuspend()` and `OSTaskResume()` respectively), post signals or messages to other tasks (i.e., call `OS??Post()`), share resources with other tasks, and more. In other words, tasks are not limited to only make "wait for an event" function calls.

Figure 5-2 shows the resources with which a task typically interacts.

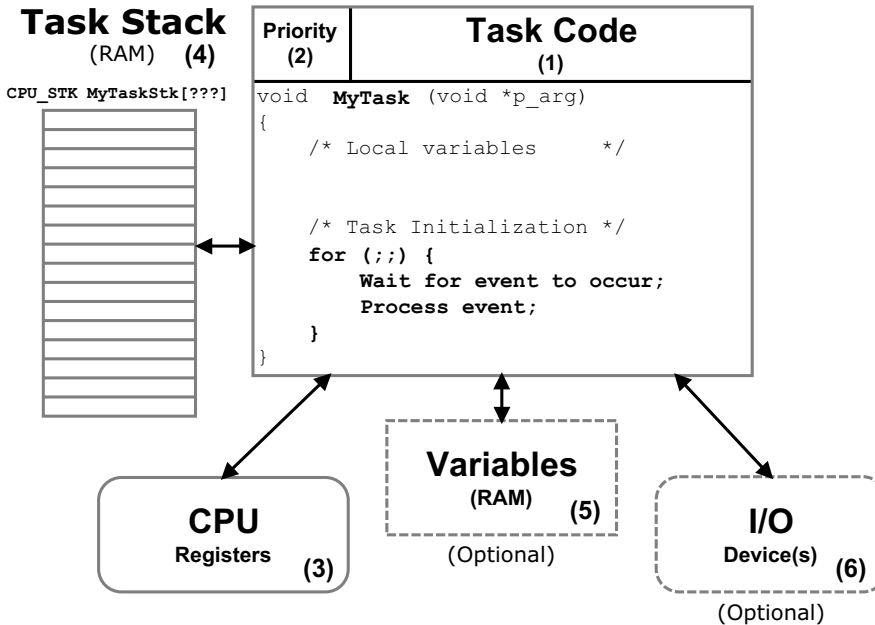

Figure 5-2 Tasks interact with resources

- F5-2(1) An important aspect of a task is its code. As previously mentioned, the code looks like any other C function, except that it is typically implemented as an infinite loop. Also, a task is not allowed to return.
- F5-2(2) Each task is assigned a priority based on its importance in the application.  $\mu\text{C}/\text{OS-III}$ 's job is to decide which task will run on the CPU. The general rule is that  $\mu\text{C}/\text{OS-III}$  will run the most important *ready-to-run* task (highest priority).

With  $\mu\text{C}/\text{OS-III}$ , a low priority number indicates a high priority. In other words, a task at priority 1 is more important than a task at priority 10.

$\mu\text{C}/\text{OS-III}$  supports a compile-time user configurable number of different priorities (see `OS_PRIO_MAX` in `OS_CFG.H`). Thus,  $\mu\text{C}/\text{OS-III}$  allows the user to determine the number of different priority levels the application is allowed to use. Also,  $\mu\text{C}/\text{OS-III}$  supports an unlimited number of tasks at the same priority. For example,  $\mu\text{C}/\text{OS-III}$  can be configured to have 64 different priority levels and one can assign dozens of tasks at each priority level.

See section 5-1 "Assigning Task Priorities" on page 84.

F5-2(3) A task has its own set of CPU registers. As far as a task is concerned, the task thinks it has the actual CPU all to itself.

F5-2(4) Because  $\mu$ C/OS-III is a preemptive kernel, each task must have its own stack area. The stack always resides in RAM and is used to keep track of local variables, function calls, and possibly ISR (Interrupt Service Routine) nesting.

Stack space can be allocated either statically (at compile-time) or dynamically (at run-time). A static stack declaration is shown below. This declaration is made outside of a function.

```
static CPU_STK MyTaskStk[???];
```

or,

```
CPU_STK MyTaskStk[???];
```

Note that “???” indicates that the size of the stack (and thus the array) depends on the task stack requirements. Stack space may be allocated dynamically by using the C compiler’s heap management function (i.e., `malloc()`) as shown below. However, care must be taken with fragmentation. If creating and deleting tasks, the process of allocating memory might not be able to provide a stack for the task(s) because the heap will eventually become fragmented. For this reason, allocating stack space dynamically in an embedded system is typically allowed but, once allocated, stacks should not be deallocated. Said another way, it’s fine to create a task’s stack from the heap as long as you don’t free the stack space back to the heap.

```
void SomeCode (void)
{
    CPU_STK *p_stk;
    :
    :
    p_stk = (CPU_STK *)malloc(stk_size);
    if (p_stk != (CPU_STK *)0) {
        Create the task and pass it "p_stk" as the base address of the stack;
    }
    :
    :
}
```

See section 5-2 “Determining the Size of a Stack” on page 86.

- F5-2(5) A task can also have access to global variables. However, because  $\mu\text{C}/\text{OS-III}$  is a preemptive kernel care must be taken with code when accessing such variables as they may be shared between multiple tasks. Fortunately,  $\mu\text{C}/\text{OS-III}$  provides mechanisms to help with the management of such shared resources (semaphores, mutexes and more).
- F5-2(6) A task may also have access to one or more Input/Output (I/O) devices (also known as *peripherals*). In fact, it is common practice to assign tasks to manage I/O devices.

## 5-1 ASSIGNING TASK PRIORITIES

Sometimes task priorities are both obvious and intuitive. For example, if the most important aspect of the embedded system is to perform some type of control and it is known that the control algorithm must be responsive then it is best to assign the control task(s) a high priority while display and operator interface tasks are assigned low priority. However, most of the time, assigning task priorities is not so cut and dry because of the complex nature of real-time systems. In most systems, not all tasks are considered critical, and non-critical tasks should obviously be given low priorities.

An interesting technique called rate monotonic scheduling (RMS) assigns task priorities based on how often tasks execute. Simply put, tasks with the highest rate of execution are given the highest priority. However, RMS makes a number of assumptions, including:

- All tasks are periodic (they occur at regular intervals).
- Tasks do not synchronize with one another, share resources, or exchange data.
- The CPU must always execute the highest priority task that is ready to run. In other words, preemptive scheduling must be used.

Given a set of  $n$  tasks that are assigned RMS priorities, the basic RMS theorem states that all task hard real-time deadlines are always met if the following inequality holds true:

$$\sum_i \frac{E_i}{T_i} \leq n \left( 2^{1/n} - 1 \right)$$

Where  $E_i$  corresponds to the maximum execution time of task  $i$ , and  $T_i$  corresponds to the execution period of task  $i$ . In other words,  $E_i/T_i$  corresponds to the fraction of CPU time required to execute task  $i$ .

Table 5-1 shows the value for size  $n(2^{1/n} - 1)$  based on the number of tasks. The upper bound for an infinite number of tasks is given by  $\ln(2)$ , or **0.693**, which means that meeting all hard real-time deadlines based on RMS, CPU use of all time-critical tasks should be less than 70 percent!

---

Note that one can still have (and generally does) non time-critical tasks in a system and thus use close to 100 percent of the CPU's time. However, using 100 percent of your CPU's time is not a desirable goal as it does not allow for code changes and added features. As a rule of thumb, always design a system to use less than 60 to 70 percent of the CPU.

RMS says that the highest rate task has the highest priority. In some cases, the highest rate task might not be the most important task. The application dictates how to assign priorities. However, RMS is an interesting starting point.

| <b>Number of Tasks</b> | <b><math>n(2^{1/n}-1)</math></b> |
|------------------------|----------------------------------|
| 1                      | 1.00                             |
| 2                      | 0.828                            |
| 3                      | 0.779                            |
| 4                      | 0.756                            |
| 5                      | 0.743                            |
| :                      | :                                |
| :                      | :                                |
| :                      | :                                |
| Infinite               | 0.693                            |

Table 5-1 Allowable CPU usage based on number of tasks

## 5-2 DETERMINING THE SIZE OF A STACK

The size of the stack required by the task is application specific. When sizing the stack, however, one must account for the nesting of all the functions called by the task, the number of local variables to be allocated by all functions called by the task, and the stack requirements for all nested interrupt service routines. In addition, the stack must be able to store all CPU registers and possibly Floating-Point Unit (FPU) registers if the processor has a FPU. As a general rule in embedded systems, avoid writing recursive code.

It is possible to manually figure out the stack space needed by adding all the memory required by all function call nesting (1 pointer each function call for the return address), plus all the memory required by all the arguments passed in those function calls, plus storage for a full CPU context (depends on the CPU), plus another full CPU context for each nested ISRs (if the CPU doesn't have a separate stack to handle ISRs), plus whatever stack space is needed by those ISRs. Adding all this up is a tedious chore and the resulting number is a minimum requirement. Most likely one would not make the stack size that precise in order to account for "surprises." The number arrived at should probably be multiplied by some safety factor, possibly 1.5 to 2.0. This calculation assumes that the exact path of the code is known at all times, which is not always possible. Specifically, when calling a function such as `printf()` or some other library function, it might be difficult or nearly impossible to even guess just how much stack space `printf()` will require. In this case, start with a fairly large stack space and monitor the stack usage at run-time to see just how much stack space is actually used after the application runs for a while.

There are really cool and clever compilers/linkers that provide this information in a link map. For each function, the link map indicates the worst-case stack usage. This feature clearly enables one to better evaluate stack usage for each task. It is still necessary to add the stack space for a **full CPU** context plus, another **full CPU** context for each nested ISR (if the CPU does not have a separate stack to handle ISRs), plus whatever stack space is needed by those ISRs. Again, allow for a safety net and multiply this value by some factor.

Always monitor stack usage at run-time while developing and testing the product as stack overflows occur often and can lead to some curious behaviors. In fact, whenever someone mentions that his or her application behaves "strangely," insufficient stack size is the first thing that comes to mind.



## 5-3 DETECTING TASK STACK OVERFLOWS

### 1) Using an MMU or MPU

Stack overflows are easily detected if the processor has a Memory Management Unit (MMU) or a Memory Protection Unit (MPU). Basically, MMUs and MPUs are special hardware devices integrated alongside the CPU that can be configured to detect when a task attempts to access invalid memory locations, whether code, data, or stack. Setting up an MMU or MPU is well beyond the scope of this book.

### 2) Using a CPU with stack overflow detection

Some processors, however, do have simple stack pointer overflow detection registers. When the CPU's stack pointer goes below (or above depending on stack growth) the value set in this register, an exception is generated and the exception handler ensures that the offending code does not do further damage (possibly issue a warning about the faulty code). The `.StkLimitPtr` field in the `OS_TCB` (see Task Control Blocks) is provided for this purpose as shown in Figure 5-3. Note that the position of the stack limit is typically set at a valid location in the task's stack with sufficient room left on the stack to handle the exception itself (assuming the CPU does not have a separate exception stack). In most cases, the position can be fairly close to `&MyTaskStk[0]`.

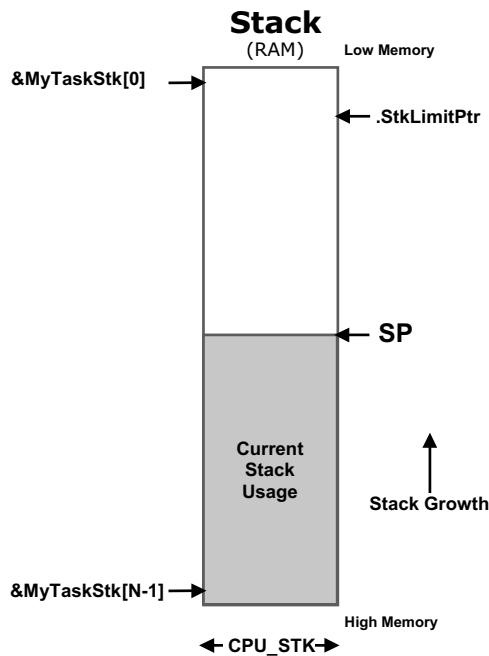

Figure 5-3 Hardware detection of stack overflows

As a reminder, the location of the `.StkLimitPtr` is determined by the “`stk_limit`” argument passed to `OSTaskCreate()`, when the task is created as shown below:

```
OS_TCB MtTaskTCB;
CPU_STK MyTaskStk[1000];

OSTaskCreate(&MyTaskTCB,
            "MyTaskName",
            MyTask,
            &MyTaskArg,
            MyPrio,
            &MyTaskStk[0], /* Stack base address */
            100,           /* Set .StkLimitPtr to trigger exception at stack usage > 90% */
            1000,         /* Total stack size (in CPU_STK elements) */
            MyTaskQSize,
            MyTaskTimeQuanta,
            (void *)0,
            MY_TASK_OPT,
            &err);
```

Of course, the value of `.StkLimitPtr` used by the CPU's stack overflow detection hardware needs to be changed whenever  $\mu\text{C}/\text{OS-III}$  performs a context switch. This can be tricky because the value of this register may need to be changed so that it first points to `NULL`, then change the CPU's stack pointer, and finally set the value of the stack checking register to the value saved in the TCB's `.StkLimitPtr`. Why? Because if the sequence is not followed, the exception could be generated as soon as the stack pointer or the stack overflow detection register is changed. One can avoid this problem by first changing the stack overflow detection register to point to a location that ensures the stack pointer is never invalid (thus the `NULL` as described above). Note that I assumed here that the stack grows from high memory to low memory but the concept works in a similar fashion if the stack grows in the opposite direction.

### 3) Software-based stack overflow detection

Whenever  $\mu\text{C}/\text{OS-III}$  switches from one task to another, it calls a “hook” function (`OSTaskSwHook()`), which allows the  $\mu\text{C}/\text{OS-III}$  port programmer to extend the capabilities of the context switch function. So, if the processor doesn't have hardware stack pointer overflow detection, it's still possible to “simulate” this feature by adding code in the context switch hook function and, perform the overflow detection in software. Specifically, before a task is *switched* in, the code should ensure that the stack pointer to load into the CPU does not exceed the “limit” placed in `.StkLimitPtr`. Because the software implementation

cannot detect the stack overflow “as soon” as the stack pointer exceeds the value of `.StkLimitPtr`, it is important to position the value of `.StkLimitPtr` in the stack fairly far from `&MyTaskStk[0]`, as shown in Figure 5-4. A software implementation such as this is not as reliable as a hardware-based detection mechanism but still prevents a possible stack overflow. Of course, the `.StkLimitPtr` field would be set using `OSTaskCreate()` as shown above but this time, with a location further away from `&MyTaskStk[0]`.

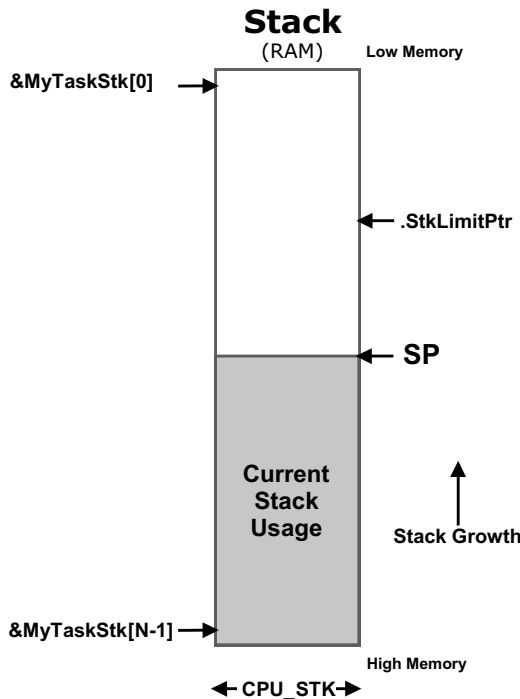

Figure 5-4 Software detection of stack overflows, monitoring `.StkLimitPtr`

#### 4) Counting the amount of free stack space

Another way to check for stack overflows is to allocate more stack space than is anticipated to be used for the stack, then, monitor and possibly display actual maximum stack usage at run-time. This is fairly easy to do. First, the task stack needs to be cleared (i.e., filled with zeros) when the task is created. Next, a low priority task *walks the stack* of each task created, from the bottom (`&MyTaskStk[0]`) towards the top, counting the number of zero entries. When the task finds a non-zero value, the process is stopped and the usage of the stack can be computed (in number of bytes used or as a percentage). Then, adjust the size of the stacks (by recompiling the code) to allocate a more *reasonable* value (either increase or decrease the amount of stack space for each task). For this to be effective, however, run

the application long enough for the stack to grow to its highest value. This is illustrated in Figure 5-5.  $\mu\text{C}/\text{OS-III}$  provides a function that performs this calculation at run-time, `OSTaskStkChk()` and in fact, this function is called by `OS_StatTask()` to compute stack usage for every task created in the application (to be described later).

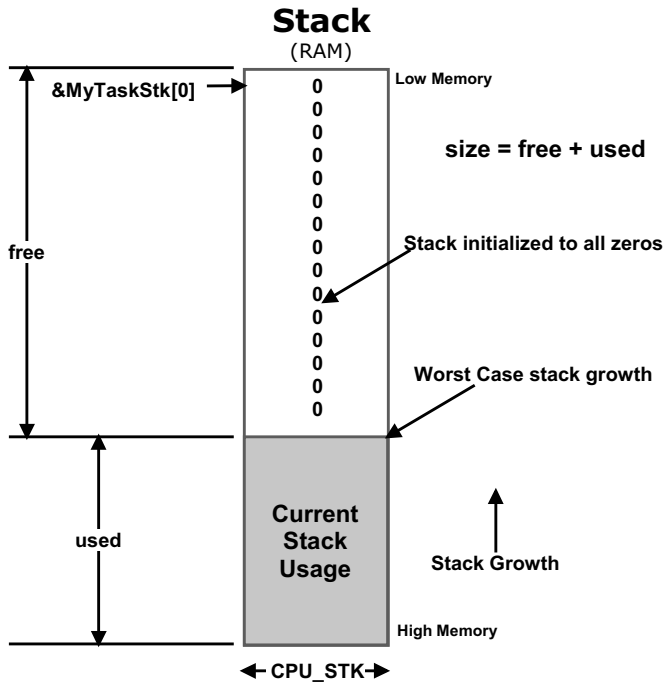

Figure 5-5 Software detection of stack overflows, walking the stack

## 5-4 TASK MANAGEMENT SERVICES

$\mu$ C/OS-III provides a number of task-related services to call from the application. These services are found in `OS_TASK.C` and they all start with `OSTask???( )`. The type of service they perform groups task-related services:

| Group  | Functions   |
|--|---|
| General  | <code>OSTaskCreate( )</code><br><code>OSTaskDel( )</code><br><code>OSTaskChangePrio( )</code><br><code>OSTaskRegSet( )</code><br><code>OSTaskRegGet( )</code><br><code>OSTaskSuspend( )</code><br><code>OSTaskResume( )</code><br><code>OSTaskTimeQuantaSet( )</code> |
| Signaling a Task<br>(See also Chapter 14, “Synchronization” on page 251)           | <code>OSTaskSemPend( )</code><br><code>OSTaskSemPost( )</code><br><code>OSTaskSemPendAbort( )</code>  |
| Sending Messages to a Task<br>(See also Chapter 15, “Message Passing” on page 289) | <code>OSTaskQPend( )</code><br><code>OSTaskQPost( )</code><br><code>OSTaskQPendAbort( )</code><br><code>OSTaskQFlush( )</code>  |

Table 5-2 Task Management Services

A complete description of all  $\mu$ C/OS-III task related services is provided in Appendix A, “ $\mu$ C/OS-III API Reference Manual” on page 375.

## 5-5 TASK MANAGEMENT INTERNALS

### 5-5-1 TASK STATES

From a  $\mu\text{C}/\text{OS-III}$  user point of view, a task can be in any one of five states as shown in Figure 5-6. Internally,  $\mu\text{C}/\text{OS-III}$  does not need to keep track of the dormant state and the other states are tracked slightly differently. This will be discussed after a discussion on task states from the user's point of view. Figure 5-6 also shows which  $\mu\text{C}/\text{OS-III}$  functions are used to move from one state to another. The diagram is actually simplified as state transitions are a bit more complicated than this.

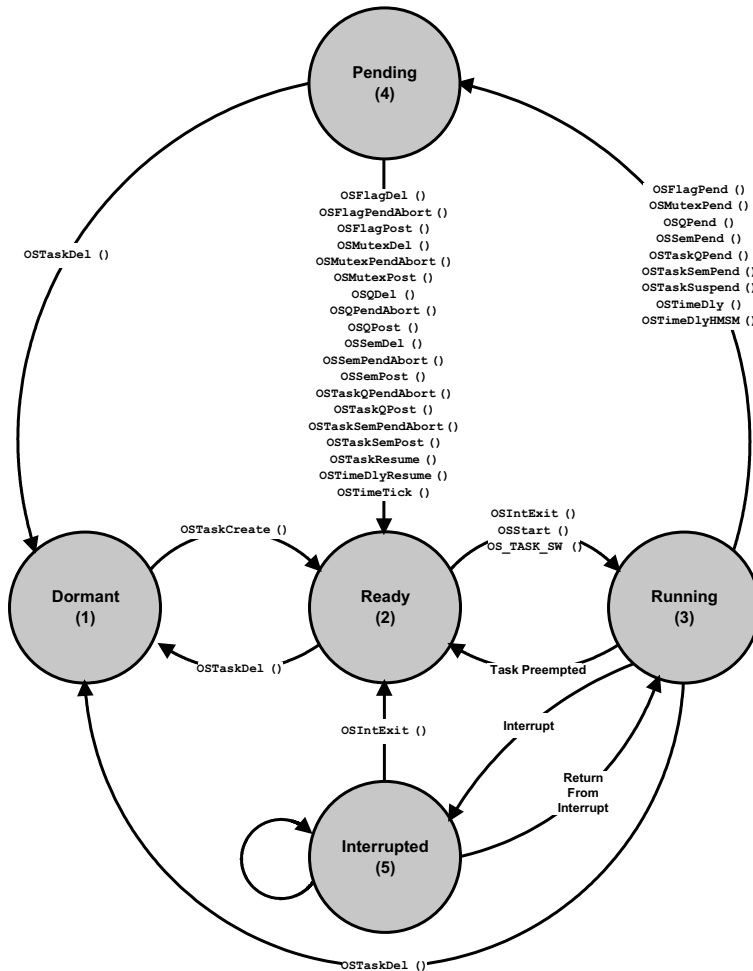

Figure 5-6 Five basic states of a task

F5-6(1) The *Dormant* state corresponds to a task that resides in memory but has not been made available to  $\mu\text{C}/\text{OS-III}$ .

A task is made available to  $\mu\text{C}/\text{OS-III}$  by calling a function to create the task, `OSTaskCreate()`. The task code actually resides in code space but  $\mu\text{C}/\text{OS-III}$  needs to be informed about it.

When it is no longer necessary for  $\mu\text{C}/\text{OS-III}$  to manage a task, call the task delete function, `OSTaskDel()`. `OSTaskDel()` does not actually delete the code of the task, it is simply not eligible to access the CPU.

F5-6(2) The *Ready* state corresponds to a ready-to-run task, but is not the most important task ready. There can be any number of tasks ready and  $\mu\text{C}/\text{OS-III}$  keeps track of all ready tasks in a **ready list** (discussed later). This list is sorted by priority.

F5-6(3) The most important ready-to-run task is placed in the *Running* state. On a single CPU, only one task can be running at any given time.

The task selected to run on the CPU is *switched in* by  $\mu\text{C}/\text{OS-III}$  from the ready state when the application code calls `OSStart()`, or when  $\mu\text{C}/\text{OS-III}$  calls either `OSIntExit()` or `OS_TASK_SW()`.

As previously discussed, tasks must wait for an event to occur. A task waits for an event by calling one of the functions that brings the task to the pending state if the event has not occurred.

F5-6(4) Tasks in the *Pending* state are placed in a special list called a *pend-list* (or wait list) associated with the event the task is waiting for. When waiting for the event to occur, the task does not consume CPU time. When the event occurs, the task is placed back into the ready list and  $\mu\text{C}/\text{OS-III}$  decides whether the newly readied task is the most important ready-to-run task. If this is the case, the currently running task will be preempted (placed back in the ready list) and the newly readied task is given control of the CPU. In other words, the newly readied task will run immediately if it is the most important task.

Note that the `OSTaskSuspend()` function unconditionally blocks a task and this task will not actually wait for an event to occur but in fact, waits until another task calls `OSTaskResume()` to make the task ready to run.

F5-6(5) Assuming that CPU interrupts are enabled, an interrupting device will suspend execution of a task and execute an Interrupt Service Routine (ISR). ISRs are typically events that tasks wait for. Generally speaking, an ISR should simply notify a task that an event occurred and let the task process the event. ISRs should be as short as possible and most of the work of handling the interrupting devices should be done at the task level where it can be managed by  $\mu\text{C}/\text{OS-III}$ . ISRs are only allowed to make “Post” calls (i.e., `OSFlagPost()`, `OSQPost()`, `OSSemPost()`, `OSTaskQPost()` and `OSTaskSemPost()`). The only post call not allowed to be made from an ISR is `OSMutexPost()` since mutexes, as will be addressed later, are assumed to be services that are only accessible at the task level.

As the state diagram indicates, an interrupt can interrupt another interrupt. This is called **interrupt nesting** and most processors allow this. However, interrupt nesting easily leads to stack overflow if not managed properly.

Internally,  $\mu\text{C}/\text{OS-III}$  keeps track of task states using the state machine shown in Figure 5-7. The task state is actually maintained in a variable that is part of a data structure associated with each task, the task's TCB. The task state diagram was referenced throughout the design of  $\mu\text{C}/\text{OS-III}$  when implementing most of  $\mu\text{C}/\text{OS-III}$ 's services. The number in parentheses is the state number of the task and thus, a task can be in any one of eight (8) states (see **OS.H**, `OS_TASK_STATE_???`).

Note that the diagram does not keep track of a dormant task, as a dormant task is not known to  $\mu\text{C}/\text{OS-III}$ . Also, interrupts and interrupt nesting is tracked differently as will be explained further in the text.

This state diagram should be quite useful to understand how to use several functions and their impact on the state of tasks. In fact, I'd highly recommend that the reader bookmark the page of the diagram.

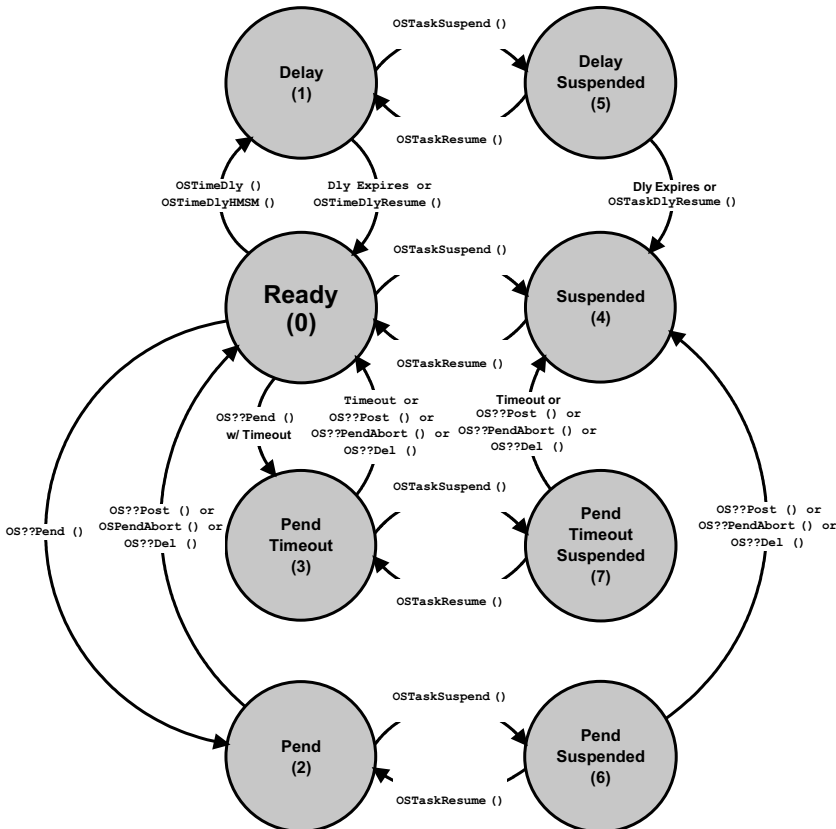

Figure 5-7  $\mu\text{C}/\text{OS-III}$ 's internal task state machine

- F5-7(1) State 0 occurs when a task is ready to run. Every task “wants” to be ready to run as that is the only way it gets to perform their duties.
- F5-7(2) A task can decide to wait for time to expire by calling either `OSTimeDly()` or `OSTimeDlyHMSM()`. When the time expires or the delay is cancelled (by calling `OSTimeDlyResume()`), the task returns to the ready state.
- F5-7(3) A task can wait for an event to occur by calling one of the pend (i.e., wait) functions (`OSFlagPend()`, `OSMutexPend()`, `OSQPend()`, `OSSemPend()`, `OSTaskQPend()`, or `OSTaskSemPend()`), and specify to wait forever for the event to occur. The pend terminates when the event occurs (i.e., a task or an ISR performs a “post”), the awaited object is deleted or, another task decides to abort the pend.

- F5-7(4) A task can wait for an event to occur as indicated, but specify that it is willing to wait a certain amount of time for the event to occur. If the event is not posted within that time, the task is readied, then the task is notified that a timeout occurred. Again, the pend terminates when the event occurs (i.e., a task or an ISR performs a “post”), the object awaited is deleted or, another task decides to abort the pend.
- F5-7(5) A task can suspend itself or another task by calling `OSTaskSuspend()`. The only way the task is allowed to resume execution is by calling `OSTaskResume()`. Suspending a task means that a task will not be able to run on the CPU until it is resumed by another task.
- F5-7(6) A delayed task can also be suspended by another task. In this case, the effect is additive. In other words, the delay must complete (or be resumed by `OSTimeDlyResume()`) and the suspension must be removed (by another task which would call `OSTaskResume()`) in order for the task to be able to run.
- F5-7(7) A task waiting on an event to occur may be suspended by another task. Again, the effect is additive. The event must occur and the suspension removed (by another task) in order for the task to be able to run. Of course, if the object that the task is pending on is deleted or, the pend is aborted by another task, then one of the above two condition is removed. The suspension, however, must be explicitly removed.
- F5-7(8) A task can wait for an event, but only for a certain amount of time, and the task could also be suspended by another task. As one might expect, the suspension must be removed by another task (or the same task that suspended it in the first place), and the event needs to either occur or timeout while waiting for the event.

## 5-5-2 TASK CONTROL BLOCKS (TCBs)

A task control block (TCB) is a data structure used by kernels to maintain information about a task. Each task requires its own TCB and, for  $\mu\text{C}/\text{OS-III}$ , the user assigns the TCB in user memory space (RAM). The address of the task's TCB is provided to  $\mu\text{C}/\text{OS-III}$  when calling task-related services (i.e., `OSTask???( )` functions). The task control block data structure is declared in `OS.H` as shown in Listing 5-3. Note that the fields are actually commented in `OS.H`, and some of the fields are conditionally compiled based on whether or not certain features are desired. Both are not shown here for clarity.

Also, it is important to note that even when the user understands what the different fields of the `OS_TCB` do, the application code must never directly access these (especially change them). In other words, `OS_TCB` fields must only be accessed by  $\mu\text{C}/\text{OS-III}$  and not the code.

```
struct os_tcb {
    CPU_STK          *StkPtr;
    void             *ExtPtr;
    CPU_STK          *StkLimitPtr;
    OS_TCB           *NextPtr;
    OS_TCB           *PrevPtr;
    OS_TCB           *TickNextPtr;
    OS_TCB           *TickPrevPtr;
    OS_TICK_SPOKE    *TickSpokePtr;
    OS_CHAR          *NamePtr;
    CPU_STK          *StkBasePtr;
    OS_TASK_PTR      TaskEntryAddr;
    void             *TaskEntryArg;
    OS_PEND_DATA     *PendDataTblPtr;
    OS_OBJ_QTY       PendDataEntries;
    CPU_TS           TS;
    void             *MsgPtr;
    OS_MSG_SIZE      MsgSize;
    OS_MSG_Q         MsgQ;
    CPU_TS           MsgQPendTime;
    CPU_TS           MsgQPendTimeMax;
    OS_FLAGS         FlagsPend;
    OS_OPT           FlagsOpt;
    OS_FLAGS         FlagsRdy;
```

```

OS_REG          RegTbl[OS_TASK_REG_TBL_SIZE];
OS_SEM_CTR      SemCtr;
CPU_TS          SemPendTime;
CPU_TS          SemPendTimeMax;
OS_NESTING_CTR  SuspendCtr;
CPU_STK_SIZE    StkSize;
CPU_STK_SIZE    StkUsed;
CPU_STK_SIZE    StkFree;
OS_OPT          Opt;
OS_TICK         TickCtrPrev;
OS_TICK         TickCtrMatch;
OS_TICK         TickRemain;
OS_TICK         TimeQuanta;
OS_TICK         TimeQuantaCtr;
OS_CPU_USAGE    CPUUsage;
OS_CTX_SW_CTR   CtxSwCtr;
CPU_TS          CyclesDelta;
CPU_TS          CyclesStart;
OS_CYCLES       CyclesTotal;
CPU_TS          IntDisTimeMax;
CPU             SchedLockTimeMax;
OS_STATE        PendOn;
OS_STATUS       PendStatus;
OS_STATE        TaskState;
OS_PRIO         Prio;
OS_TCB          DbgNextPtr;
OS_TCB          DbgPrevPtr;
CPU_CHAR        DbgNamePtr;
};

```

Listing 5-3 OS\_TCB Data Structure

**.StkPtr**

This field contains a pointer to the current top-of-stack for the task.  $\mu$ C/OS-III allows each task to have its own stack and each stack can be any size. **.StkPtr** should be the only field in the **OS\_TCB** data structure accessed from assembly language code (for the context-switching code). This field is therefore placed as the first entry in the structure making access easier from assembly language code (it will be at offset zero in the data structure).

**.ExtPtr**

This field contains a pointer to a user-definable pointer to extend the TCB as needed. This pointer is easily accessible from assembly language.

**.StkLimitPtr**

The field contains a pointer to a location in the task's stack to set a *watermark* limit for stack growth and is determined from the value of the “`stk_limit`” argument passed to `OSTaskCreate()`. Some processors have special registers that automatically check the value of the stack pointer at run-time to ensure that the stack does not overflow. `.StkLimitPtr` may be used to set this register during a context switch. Alternatively, if the processor does not have such a register, this can be “simulated” in software. However, it is not as reliable as a hardware solution. If this feature is not used then the value of “`stk_limit`” can be set to 0 when calling `OSTaskCreate()`. See also section 5-3 “Detecting Task Stack Overflows” on page 87).

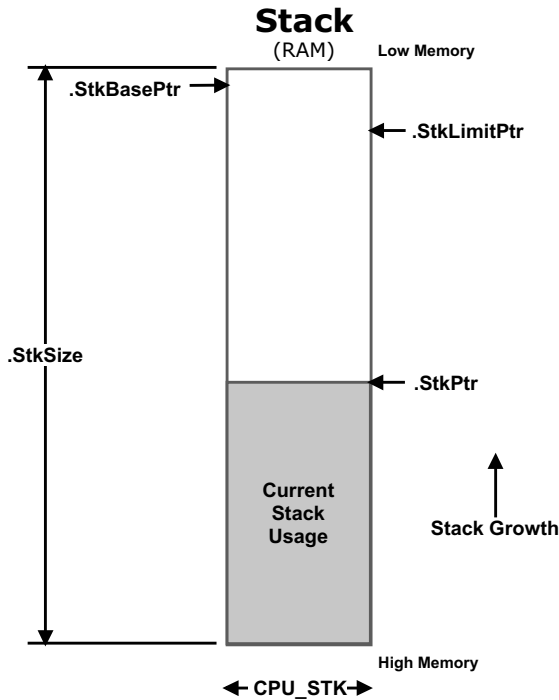
**.NextPtr** and **.PrevPtr**

These pointers are used to doubly link `OS_TCBs` in the ready list. A doubly linked list allows `OS_TCBs` to be quickly inserted and removed from the list.

**.TickNextPtr** and **.TickPrevPtr**

These pointers are used to doubly link `OS_TCBs` in the list of tasks waiting for time to expire or to timeout from pend calls. Again, a doubly linked list allows `OS_TCBs` to be quickly inserted and removed from the list.

### **.TickSpokePtr**

This pointer is used to know which spoke in the “tick wheel” the task is linked to. The tick wheel will be described in “Chapter 9, “Interrupt Management” on page 157.”

### **.NamePtr**

This pointer allows a name (an ASCII string) to be assigned to each task. Having a name is useful when debugging, since it is user friendly compared to displaying the address of the `OS_TCB`. Storage for the ASCII string is assumed to be in user space in code memory (ASCII string declared as a `const`) or in RAM.

### **.StkBasePtr**

This field points to the base address of the task’s stack. The stack base is typically the lowest address in memory where the stack for the task resides. A task stack is declared as follows:

```
CPU_STK MyTaskStk[???];
```

`CPU_STK` is the data type you must use to declare task stacks and `???` is the size of the stack associated with the task. The base address is always `&MyTaskStk[0]`.

### **.TaskEntryAddr**

This field contains the entry address of the task. As previously mentioned, a task is declared as shown below and this field contains the address of `MyTask`.

```
void MyTask (void *p_arg);
```

### **.TaskEntryArg**

This field contains the value of the argument that is passed to the task when the task starts. As previously mentioned, a task is declared as shown below and this field contains the value of `p_arg`.

```
void MyTask (void *p_arg);
```

### **.PendDataTblPtr**

$\mu$ C/OS-III allows the task to pend on any number of semaphores or message queues simultaneously. This pointer points to a table containing information about the pended objects.

**.PendDataEntries**

This field works with the `.PendDataTblPtr`, indicating the number of objects a task is pending on at the same time.

**.TS**

This field is used to store a “time stamp” of when an event that the task was waiting on occurred. When the task resumes execution, this time stamp is returned to the caller.

**.MsgPtr**

When a message is sent to a task, this field contains the message received. This field only exists in a TCB if message queue services (`OS_CFG_Q_EN` is set to 1 in `OS_CFG.H`), or task message queue services, are enabled (`OS_CFG_TASK_Q_EN` is set to 1 in `OS_CFG.H`) at compile time.

**.MsgSize**

When a message is sent to a task, this field contains the size (in number of bytes) of the message received. This field only exists in a TCB if message queue services (`OS_CFG_Q_EN` is set to 1 in `OS_CFG.H`), or task message queue services, (`OS_CFG_TASK_Q_EN` is set to 1 in `OS_CFG.H`) are enabled at compile time.

**.MsgQ**

$\mu$ C/OS-III allows tasks or ISRs to send messages directly to tasks. Because of this, a message queue is actually built into each TCB. This field only exists in a TCB if task message queue services are enabled at compile time (`OS_CFG_TASK_Q_EN` is set to 1 in `OS_CFG.H`). `.MsgQ` is used by the `OSTaskQ???`( ) services.

**.MsgQPendTime**

This field contains the amount of time for a message to arrive. When `OSTaskQPost()` is called, the current time stamp is read and stored in the message. When `OSTaskQPend()` returns, the current time stamp is read again and the difference between the two times is stored in this variable. A debugger or  $\mu$ C/Probe can be used to indicate the time taken for a message to arrive by displaying this field.

This field is only available if setting `OS_CFG_TASK_PROFILE_EN` to 1 in `OS_CFG.H`.

### **.MsgQPendTimeMax**

This field contains the maximum amount of time it takes for a message to arrive. It is a peak detector of the value of `.MsgQPendTime`. The peak can be reset by calling `OSStatReset()`.

This field is only available if setting `OS_CFG_TASK_PROFILE_EN` to 1 in `OS_CFG.H`.

### **.FlagsPend**

When a task pends on event flags, this field contains the event flags (i.e., bits) that the task is pending on. This field only exists in a TCB if event flags services are enabled at compile time (`OS_CFG_FLAG_EN` is set to 1 in `OS_CFG.H`).

### **.FlagsOpt**

When a task pends on event flags, this field contains the type of pend (pend on any event flag bit specified in `.FlagsPend` or all event flag bits specified in `.FlagsPend`). This field only exists in a TCB if event flags services are enabled at compile time (`OS_CFG_FLAG_EN` is set to 1 in `OS_CFG.H`).

### **.FlagsRdy**

This field contains the event flags that were posted and that the task was waiting on. In other words, it allows a task to know which event flags made the task ready to run. This field only exists in a TCB if event flags services are enabled at compile time (`OS_CFG_FLAG_EN` is set to 1 in `OS_CFG.H`).

### **.RegTbl[]**

This field contains a table of “registers” that are task-specific. These registers are different than CPU registers. Task registers allow for the storage of such task-specific information as task ID, “`errno`” common in some software components, and more. Task registers may also store task-related data that needs to be associated with the task at run time. Note that the data type for elements of this array is `OS_REG`, which can be declared at compile time to be nearly anything. However, all registers must be of this data type. This field only exists in a TCB if task registers are enabled at compile time (`OS_CFG_TASK_REG_TBL_SIZE` is greater than 0 in `OS_CFG.H`).

### **.SemCtr**

This field contains a semaphore counter associated with the task. Each task has its own semaphore built-in. An ISR or another task can signal a task using this semaphore. `.SemCtr` is therefore used to keep track of how many times the task is signaled. `.SemCtr` is used by `OSTaskSem???`( ) services.



---

**.SemPendTime**

This field contains the amount of time taken for the semaphore to be signaled. When `OSTaskSemPost()` is called, the current time stamp is read and stored in the `OS_TCB` (see `.TS`). When `OSTaskSemPend()` returns, the current time stamp is read again and the difference between the two times is stored in this variable. This field can be displayed by a debugger or  $\mu$ C/Probe to indicate how much time it took for the task to be signaled.

This field is only available when setting `OS_CFG_TASK_PROFILE_EN` to 1 in `OS_CFG.H`.

**.SemPendTimeMax**

This field contains the maximum amount of time it took for the task to be signaled. It is a peak detector of the value of `.SemPendTime`. The peak can be reset by calling `OSStatReset()`.

This field is only available if setting `OS_CFG_TASK_PROFILE_EN` to 1 in `OS_CFG.H`.

**.SuspendCtr**

This field is used by `OSTaskSuspend()` and `OSTaskResume()` to keep track of how many times a task is suspended. Task suspension can be nested. When `.SuspendCtr` is 0, all suspensions are removed. This field only exists in a TCB if task suspension is enabled at compile time (`OS_CFG_TASK_SUSPEND_EN` is set to 1 in `OS_CFG.H`).

**.StkSize**

This field contains the size (in number of `CPU_STK` elements) of the stack associated with the task. Recall that a task stack is declared as follows:

```
CPU_STK MyTaskStk[???];
```

`.StkSize` is the value of `???` in the above array.

**.StkUsed** and **.StkFree**

$\mu$ C/OS-III is able to compute (at run time) the amount of stack space a task actually uses and how much stack space remains. This is accomplished by a function called `OSTaskStkChk()`. Stack usage computation assumes that the task's stack is "cleared" when the task is created. In other words, when calling `OSTaskCreate()`, it is expected that the following options be specified: `OS_TASK_OPT_STK_CLR` and `OS_TASK_OPT_STK_CHK`. `OSTaskCreate()` will then clear all the RAM used for the task's stack.

$\mu$ C/OS-III provides an internal task called `OS_StatTask()` that checks the stack of each of the tasks at run-time. `OS_StatTask()` typically runs at a low priority so that it does not interfere with the application code. `OS_StatTask()` saves the value computed for each task in the TCB of each task in these fields, which represents the maximum number of stack bytes used and the amount of stack space still unused by the task. These fields only exist in a TCB if the statistic task is enabled at compile time (`OS_CFG_STAT_TASK_STK_CHK_EN` is set to 1 in `OS_CFG.H`).

#### **.Opt**

This field saves the “options” passed to `OSTaskCreate()` when the task is created (see `OS_TASK_OPT_???` in `OS.H`). Note that task options are additive.

#### **.TickCtrPrev**

This field stores the previous value of `OSTickCtr` when `OSTimeDly()` is called with the `OS_OPT_TIME_PERIODIC` option.

#### **.TickCtrMatch**

When a task is waiting for time to expire, or pending on an object with a timeout, the task is placed in a special list of tasks waiting for time to expire. When in this list, the task waits for `.TickCtrMatch` to match the value of the “tick counter” (`OSTickCtr`). When a match occurs, the task is removed from that list.

#### **.TickRemain**

This field is computed at run time by `OS_TickTask()` to compute the amount of time (expressed in “ticks”) left before a delay or timeout expires. This field is useful for debuggers or run-time monitors for display purposes.

#### **.TimeQuanta and .TimeQuantaCtr**

These fields are used for time slicing. When multiple tasks are ready to run at the same priority, `.TimeQuanta` determines how much time (in ticks) the task will execute until it is preempted by  $\mu$ C/OS-III so that the next task at the same priority gets a chance to execute. `.TimeQuantaCtr` keeps track of the remaining number of ticks for this to happen and is loaded with `.TimeQuanta` at the beginning of the task’s time slice.

#### **.CPUUsage**

This field is computed by `OS_StatTask()` if `OS_CFG_TASK_PROFILE_EN` is set to 1 in `OS_CFG.H`. `.CPUUsage` contains the CPU usage of a task in percent (0 to 100%).

**.CtxSwCtr**

This field keeps track of how often the task has executed (not how long it has executed). This field is generally used by debuggers or run-time monitors to see if a task is executing (the value of this field would be non-zero and would be incrementing). The field is enabled at compile time when `OS_CFG_TASK_PROFILE_EN` is set to 1.

**.CyclesDelta**

**.CyclesDelta** is computed during a context switch and contains the value of the current time stamp (obtained by calling `OS_TS_GET()`) minus the value of **.CyclesStart**. This field is generally used by debuggers or a run-time monitor to see how long a task takes to execute. The field is enabled at compile time when `OS_CFG_TASK_PROFILE_EN` is set to 1.

**.CyclesStart**

This field is used to measure the execution time of a task. **.CyclesStart** is updated when  $\mu$ C/OS-III performs a context switch. **.CyclesStart** contains the value of the current time stamp (it calls `OS_TS_GET()`) when a task switch occurs. This field is generally used by debuggers or a run-time monitor to see how long a task takes to execute. The field is enabled at compile time when `OS_CFG_TASK_PROFILE_EN` is set to 1.

**.CyclesTotal**

This field accumulates the value of **.CyclesDelta**, so it contains the total execution time of a task. This is typically a 64-bit value because of the accumulation of cycles over time. Using a 64-bit value ensures that we can accumulate CPU cycles for almost 600 years even if the CPU is running at 1 GHz! Of course, it's assumed that the compiler supports 64-bit data types.

**.IntDisTimeMax**

This field keeps track of the maximum interrupt disable time of the task. The field is updated only if  $\mu$ C/CPU supports interrupt disable time measurements. This field is available only if setting `OS_CFG_TASK_PROFILE_EN` to 1 in `OS_CFG.H` and  $\mu$ C/CPU's `CPU_CFG_TIME_MEAS_INT_DIS_EN` is defined in `DCPU_CFG.H`.

**.SchedLockTimeMax**

The field keeps track of the maximum scheduler lock time of the task.

This field is available only if you set `OS_CFG_TASK_PROFILE_EN` to 1 and `OS_CFG_SCHED_LOCK_TIME_MEAS_EN` is set to 1 in `OS_CFG.H`.

**.PendOn**

This field indicates upon what the task is pending and contains `OS_TASK_PEND_ON_???` (see `OS.H`).

**.PendStatus**

This field indicates the outcome of a pend and contains `OS_STATUS_PEND_???` (see `OS.H`).

**.TaskState**

This field indicates the current state of a task and contains one of the eight (8) task states that a task can be in, see `OS_TASK_STATE_???` (see `OS.H`).

**.Prio**

This field contains the current priority of a task. `.Prio` is a value between 0 and `OS_CFG_PRIO_MAX-1`. In fact, the idle task is the only task at priority `OS_CFG_PRIO_MAX-1`.

**.DbgNextPtr**

This field contains a pointer to the next `OS_TCB` in a doubly linked list of `OS_TCBs`. `OS_TCBs` are placed in this list by `OSTaskCreate()`. This field is only present if `OS_CFG_DBG_EN` is set to 1 in `OS_CFG.H`. the current priority of a task.

**.DbgPrevPtr**

This field contains a pointer to the previous `OS_TCB` in a doubly linked list of `OS_TCBs`. `OS_TCBs` are placed in this list by `OSTaskCreate()`. This field is only present if `OS_CFG_DBG_EN` is set to 1 in `OS_CFG.H`.

**.DbgNamePtr**

This field contains a pointer to the name of the object that the task is pending on when the task is pending on an event flag group, a semaphore, a mutual exclusion semaphore or a message queue. This information is quite useful during debugging and thus, this field is only present if `OS_CFG_DBG_EN` is set to 1 in `OS_CFG.H`.

## 5-6 INTERNAL TASKS

During initialization, `μC/OS-III` creates a minimum of two (2) internal tasks (`OS_IdleTask()` and `OS_TickTask()`) and, three (3) optional tasks (`OS_StatTask()`, `OS_TmrTask()` and `OS_IntQTask()`). The optional tasks are created based on the value of compile-time `#defines` found in `OS_CFG.H`.

## 5-6-1 THE IDLE TASK (`OS_IdleTask()`)

`OS_IdleTask()` is the very first task created by  $\mu\text{C}/\text{OS-III}$  and always exists in a  $\mu\text{C}/\text{OS-III}$ -based application. The priority of the idle task is always set to `OS_CFG_PRIO_MAX-1`. In fact, `OS_IdleTask()` is the only task that is ever allowed to be at this priority and, as a safeguard, when other tasks are created, `OSTaskCreate()` ensures that there are no other tasks created at the same priority as the idle task. The idle task runs whenever there are no other tasks that are ready to run. The important portions of the code for the idle task are shown below (refer to `OS_CORE.C` for the complete code).

```
void OS_IdleTask (void *p_arg)
{
    while (DEF_ON) {                (1)
        OS_CRITICAL_ENTER();
        OSIdleTaskCtr++;           (2)
        OSTaskStatCtr++;
        OS_CRITICAL_EXIT();
        OSIdleTaskHook();         (3)
    }
}
```

Listing 5-4 Idle Task

L5-4(1) The idle task is a “true” infinite loop that never calls functions to “wait for an event”. This is because, on most processors, when there is “nothing to do,” the processor still executes instructions. When  $\mu\text{C}/\text{OS-III}$  determines that there is no other higher-priority task to run,  $\mu\text{C}/\text{OS-III}$  “parks” the CPU in the idle task. Instead of having an empty “for loop” doing nothing, this “idle” time is used to do something useful.

L5-4(2) Two counters are incremented whenever the idle task runs.

`OSIdleTaskCtr` is typically defined as a 32-bit unsigned integer (see `OS.H`). `OSIdleTaskCtr` is reset once when  $\mu\text{C}/\text{OS-III}$  is initialized. `OSIdleTaskCtr` is used to indicate “activity” in the idle task. In other words, if one monitors and displays `OSIdleTaskCtr`, one should expect to see a value between `0x00000000` and `0xFFFFFFFF`. The rate at which `OSIdleTaskCtr` increments depend on how busy the CPU is at running the application code. The faster the increment, the less work the CPU has to do in application tasks.

`OSStatTaskCtr` is also typically defined as a 32-bit unsigned integer (see `OS.H`) and is used by the statistic task (described later) to get a sense of CPU utilization at run time.

L5-4(3) Every time through the loop, `OS_IdleTask()` calls `OSIdleTaskHook()`, which is a function that is declared in the  $\mu\text{C}/\text{OS-III}$  port for the processor used. `OSIdleTaskHook()` allows the implementer of the  $\mu\text{C}/\text{OS-III}$  port to perform additional processing during idle time. It is very important for this code to not make calls that would cause the idle task to “wait for an event”. This is generally not a problem as most programmers developing  $\mu\text{C}/\text{OS-III}$  ports know to follow this simple rule.

`OSIdleTaskHook()` may be used to place the CPU in low-power mode for battery-powered applications or to simply not waste energy as shown in the pseudo-code below. However, doing this means that `OSStatTaskCtr` cannot be used to measure CPU utilization (described later).

```
void OSIdleTaskHook (void)
{
    /* Place the CPU in low power mode */
}
```

Typically, most processors exit low-power mode when an interrupt occurs. Depending on the processor, however, the Interrupt Service Routine (ISR) may have to write to “special” registers to return the CPU to its full or desired speed. If the ISR wakes up a high-priority task (every task is higher in priority than the idle task) then the ISR will not immediately return to the interrupted idle task, but instead switch to the higher-priority task. When the higher-priority task completes its work and waits for its event to occur,  $\mu\text{C}/\text{OS-III}$  causes a context switch to return to `OSIdleTaskHook()` just “after” the instruction that caused the CPU to enter low-power mode. In turn, `OSIdleTaskHook()` returns to `OS_IdleTask()` and causes another iteration through the “for loop.”

## 5-6-2 THE TICK TASK (`OS_TickTask()`)

Nearly every RTOS requires a periodic time source called a *Clock Tick* or *System Tick* to keep track of time delays and timeouts.  $\mu\text{C}/\text{OS-III}$ 's clock tick handling is encapsulated in the file `OS_TICK.C`.

`OS_TickTask()` is a task created by  $\mu\text{C}/\text{OS-III}$  and its priority is configurable by the user through  $\mu\text{C}/\text{OS-III}$ 's configuration file `OS_CFG_APP.H` (see `OS_CFG_TICK_TASK_PRIO`). Typically `OS_TickTask()` is set to a relatively high priority. In fact, the priority of this task is set slightly lower than the most important tasks.

`OS_TickTask()` is used by  $\mu\text{C}/\text{OS-III}$  to keep track of tasks waiting for time to expire or, for tasks that are pending on kernel objects with a timeout. `OS_TickTask()` is a periodic task and it waits for signals from the tick ISR (described in Chapter 9, "Interrupt Management" on page 157) as shown in Figure 5-8.

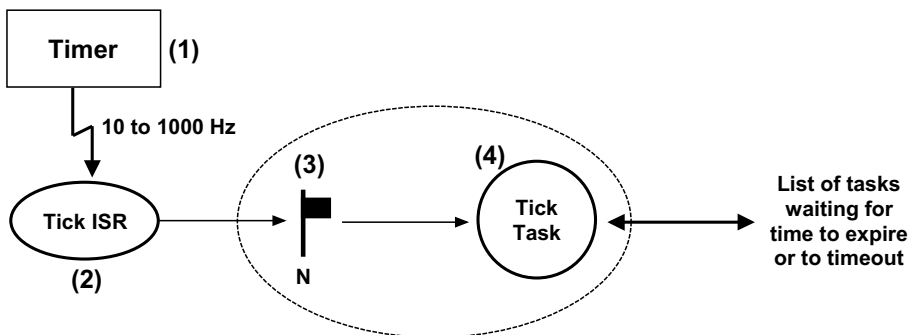

Figure 5-8 Tick ISR and Tick Task relationship

F5-8(1) A hardware timer is generally used and configured to generate an interrupt at a rate between 10 and 1000 Hz (see `OS_CFG_TICK_RATE` in `OS_CFG_APP.H`). This timer is generally called the *Tick Timer*. The actual rate to use depends on such factors as: processor speed, desired time resolution, and amount of allowable overhead to handle the tick timer, etc.

The tick interrupt does not have to be generated by a timer and, in fact, it can come from other regular time sources such as the power-line frequency (50 or 60 Hz), which are known to be fairly accurate over long periods of time.

- F5-8(2) Assuming CPU interrupts are enabled, the CPU accepts the tick interrupt, preempts the current task, and vectors to the tick ISR. The tick ISR must call `OSTimeTick()` (see `OS_TIME.C`), which accomplishes most of the work needed by  $\mu\text{C}/\text{OS-III}$ . The tick ISR then clears the timer interrupt (and possibly reloads the timer for the next interrupt). However, some timers may need to be taken care of prior to calling `OSTimeTick()` instead of after as shown below.

```
void TickISR (void)
{
    OSTimeTick();
    /* Clear tick interrupt source          */
    /* Reload the timer for the next interrupt */
}
```

or,

```
void TickISR (void)
{
    /* Clear tick interrupt source          */
    /* Reload the timer for the next interrupt */
    OSTimeTick();
}
```

`OSTimeTick()` calls `OSTimeTickHook()` at the very beginning of `OSTimeTick()` to give the opportunity to the  $\mu\text{C}/\text{OS-III}$  port developer to react as soon as possible upon servicing the tick interrupt.

- F5-8(3) `OSTimeTick()` calls a service provided by  $\mu\text{C}/\text{OS-III}$  to signal the tick task and make that task ready to run. The tick task executes as soon as it becomes the most important task. The reason the tick task might not run immediately is that the tick interrupt could have interrupted a task higher in priority than the tick task and, upon completion of the tick ISR,  $\mu\text{C}/\text{OS-III}$  will resume the interrupted task.
- F5-8(4) When the tick task executes, it goes through a list of all tasks that are waiting for time to expire or are waiting on a kernel object with a timeout. From this point forward, this will be called the tick list. The tick task will make ready to run all of the tasks in the tick list for which time or timeout has expired. The process is explained below.



μC/OS-III may need to place literally hundreds of tasks (if an application has that many tasks) in the tick list. The tick list is implemented in such a way that it does not take much CPU time to determine if time has expired for those tasks placed in the tick list and, possibly makes those tasks ready to run. The tick list is implemented as shown in Figure 5-9.

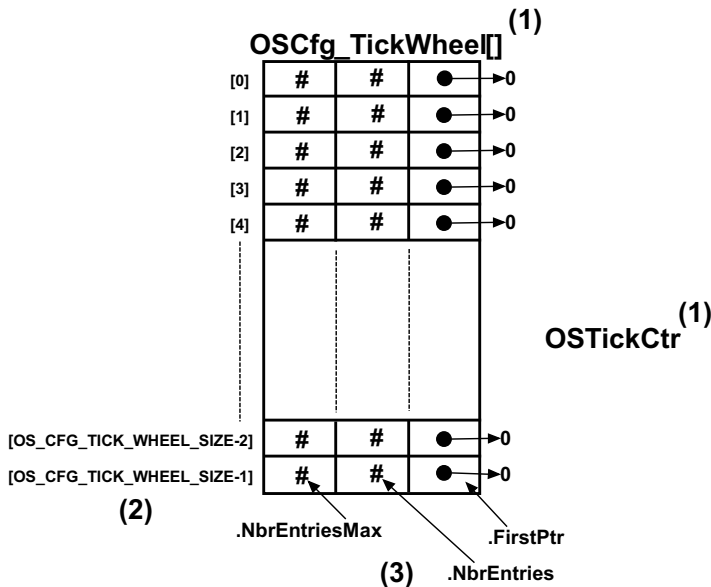

Figure 5-9 Empty Tick List

F5-9(1) The tick list consists of a table (`OSCfg_TickWheel[]`) and a counter (`OSTickCtr`).

F5-9(2) The table contains up to `OS_CFG_TICK_WHEEL_SIZE` entries, which is a compile time configuration value (see `OS_CFG_APP.H`). The number of entries depends on the amount of memory (RAM) available to the processor and the maximum number of tasks in the application. A good starting point for `OS_CFG_TICK_WHEEL_SIZE` may be:  $\#Tasks / 4$ . It is recommended not to make `OS_CFG_TICK_WHEEL_SIZE` an even multiple of the tick rate. If the tick rate is 1000 Hz and one has 50 tasks in the application, avoid setting `OS_CFG_TICK_WHEEL_SIZE` to 10 or 20 (use 11 or 23 instead). Actually, prime numbers are good choices. Although it is not really possible to plan at compile time what will happen at run time, ideally, the number of tasks waiting in each entry of the table will be distributed uniformly.

F5-9(3) Each entry in the table contains three fields: `.NbrEntriesMax`, `.NbrEntries` and `.FirstPtr`.

`.NbrEntries` indicates the number of tasks linked to this table entry.

`.NbrEntriesMax` keeps track of the highest number of entries in the table. This value is reset when the application code calls `OSStatReset()`.

`.FirstPtr` contains a pointer to a doubly linked list of tasks (through the tasks `OS_TCB`) belonging to the list, at that table position.

The counter is incremented by `OS_TickTask()` each time the task is signaled by the tick ISR.

Tasks are automatically inserted in the tick list when the application programmer calls a `OSTimeDly???`(`)` function, or when an `OS???``Pend()` call is made with a non-zero timeout value.

### Example 5-1

Using an example to illustrate the process of inserting a task in the tick list, let's assume that the tick list is completely empty, `OS_CFG_TICK_WHEEL_SIZE` is configured to 12, and the current value of `OSTickCtr` is 10 as shown in Figure 5-10. A task is placed in the tick list when `OSTimeDly()` is called and assume `OSTimeDly()` is called as follows:

```
:
OSTimeDly(1, OS_OPT_TIME_DLY, &err);
:
```

Referring to the  $\mu$ C/OS-III reference manual in Appendix A, notice that this action indicates to  $\mu$ C/OS-III to delay the current task for 1 tick. Since `OSTickCtr` has a value of 10, the task will be put to sleep until `OSTickCtr` reaches 11 or at the very next clock tick interrupt. Tasks are inserted in the `OSCfg_TickWheel[]` table using the following equation:

$$\begin{aligned} \text{MatchValue} &= \text{OSTickCtr} + \text{dly} \\ \text{Index into OSCfg\_TickWheel}[\ ] &= \text{MatchValue} \% \text{OS\_CFG\_TICK\_WHEEL\_SIZE} \end{aligned}$$

Where “dly” is the value passed in the first argument of `OSTimeDly()` or, 1 in this example. We therefore obtain the following:

```

MatchValue                = 10 + 1
Index into OSCfg_TickWheel[] = (10 + 1) % 12
    
```

or,

```

MatchValue                = 11
Index into OSCfg_TickWheel[] = 11
    
```

Because of the “circular” nature of the table (a modulo operation using the size of the table), the table is referred to as a *tick wheel* and each entry is a *spoke* in the wheel.

The OS\_TCB of the task being delayed is entered at index 11 in OSCfg\_TickWheel[] (i.e., spoke 11 using the wheel analogy). The OS\_TCB of the task is inserted in the first entry of the list (i.e., pointed to by OSCfg\_TickWheel[11].FirstPtr), and the number of entries at spoke 11 is incremented (i.e., OSCfg\_TickWheel[11].NbrEntries will be 1). Notice that the OS\_TCB also links back to &OSCfg\_TickWheel[11] and the “MatchValue” are placed in the OS\_TCB field .TickCtrMatch. Since this is the first task inserted in the tick list at spoke 11, the .TickNextPtr and .TickPrevPtr both point to NULL.

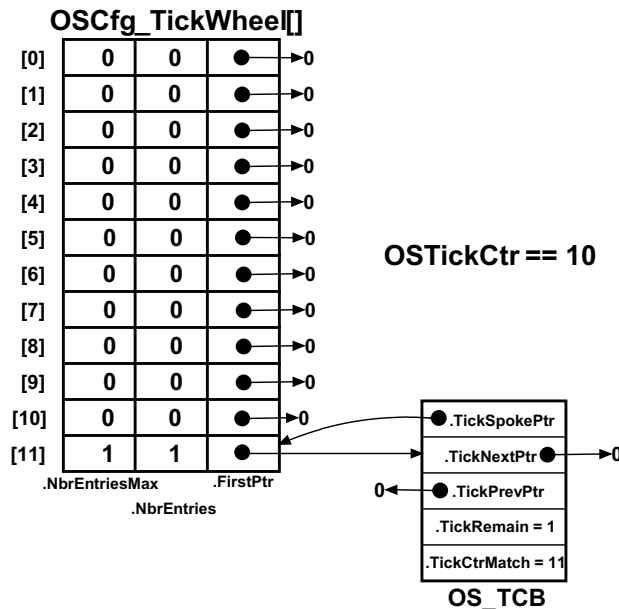

Figure 5-10 Inserting a task in the tick list

`OSTimeDly()` takes care of a few other details. Specifically, the task is removed from  $\mu\text{C}/\text{OS-III}$ 's ready list (described in Chapter 6, "The Ready List" on page 123) since the task is no longer eligible to run (because it is waiting for time to expire). Also, the scheduler is called because  $\mu\text{C}/\text{OS-III}$  will need to run the next most important ready-to-run task.

If the next task to run also happens to call `OSTimeDly()` "before" the next tick arrives and calls `OSTimeDly()` as follows:

```
      :
      OSTimeDly(13, OS_OPT_TIME_DLY, &err);
      :
```

$\mu\text{C}/\text{OS-III}$  will calculate the match value and spoke as follows:

$$\begin{aligned} \text{MatchValue} &= 10 + 13 \\ \text{OSCfg\_TickWheel}[\ ] \text{ spoke number} &= (10 + 13) \% 12 \end{aligned}$$

or,

$$\begin{aligned} \text{MatchValue} &= 23 \\ \text{OSCfg\_TickWheel}[\ ] \text{ spoke number} &= 11 \end{aligned}$$

The "second task" will be inserted at the same table entry as shown in Figure 5-11. Tasks sharing the same spoke are sorted in ascending order such that the task with the least amount of time remaining is placed at the head of the list.

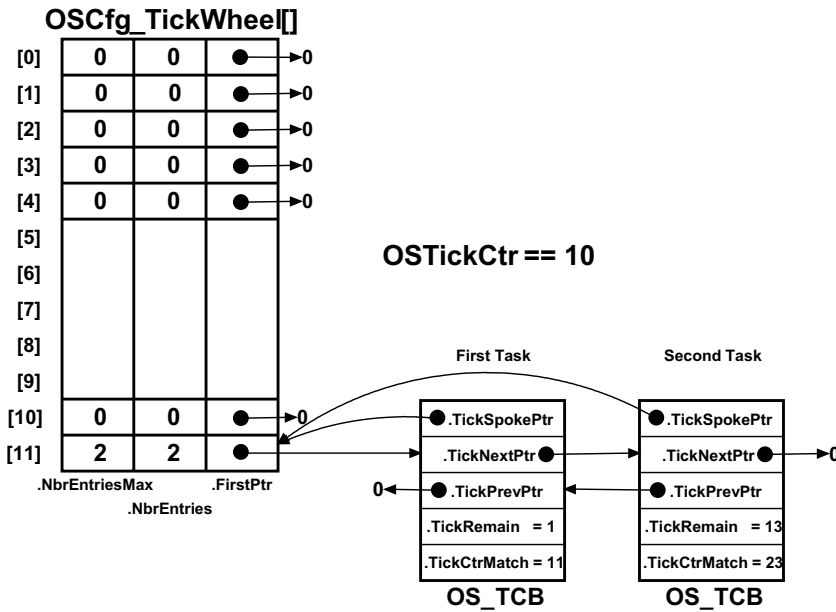

Figure 5-11 Inserting a second task in the tick list

When the tick task executes (see `OS_TickTask()` and also `OS_TickListUpdate()` in `OS_TICK.C`), it starts incrementing `OSTickCtr` and determines which table entry (i.e., which spoke) needs to be processed. Then, if there are tasks in the list at this entry (i.e., `.FirstPtr` is not `NULL`), each `OS_TCB` is examined to determine whether the `.TickCtrMatch` value “matches” `OSTickCtr` and, if so, we remove the `OS_TCB` from the list. If the task is only waiting for time to expire, it will be placed in the ready list (described later). If the task is pending on an object, not only will the task be removed from the tick list, but it will also be removed from the list of tasks waiting on that object. The search through the list terminates as soon as `OSTickCtr` does not match the task’s `.TickCtrMatch` value; since there is no point in looking any further in the list.

Note that `OS_TickTask()` does most of its work in a critical section when the tick list is updated. However, because the list is sorted, the critical section has a chance to be fairly short.

### **5-6-3 THE STATISTIC TASK (`OS_StatTask()`)**

$\mu$ C/OS-III contains an internal task that provides such run-time statistics as overall CPU utilization (0 to 100%), per-task CPU utilization (0-100%), and per-task stack usage.

The statistic task is optional in a  $\mu$ C/OS-III application and its presence is controlled by a compile-time configuration constant `OS_CFG_STAT_TASK_EN` defined in `OS_CFG.H`. Specifically, the code is included in the build when `OS_CFG_STAT_TASK_EN` is set to 1.

Also, the priority of this task and the location and size of the statistic task's stack is configurable via `OS_CFG_APP.H` (`OS_CFG_STAT_TASK_PRIO`).

If the application uses the statistic task, it should call `OSStatTaskCPUUsageInit()` from the first, and only the application task created in the `main()` function as shown in Listing 5-5. The startup code should create only one task before calling `OSStart()`. The single task created is, of course, allowed to create other tasks, but only after calling `OSStatTaskCPUUsageInit()`.

```
void main (void)                                (1)
{
    OS_ERR  err;
    :
    OSInit(&err);                                (2)
    if (err != OS_ERR_NONE) {
        /* Something wasn't configured properly,  $\mu$ C/OS-III not properly initialized */
    }
    /* (3) Create ONE task (we'll call it AppTaskStart() for sake of discussion) */
    :
    OSStart(&err);                                (4)
}

void AppTaskStart (void *p_arg)
{
    OS_ERR  err;
    :
    /* (5) Initialize the tick interrupt */
    #if OS_CFG_STAT_TASK_EN > 0
        OSStatTaskCPUUsageInit(&err);            (6)
    #endif
    :
    /* (7) Create other tasks */
    while (DEF_ON) {
        /* AppTaskStart() body */
    }
}
```

Listing 5-5 Proper startup for computing CPU utilization

- L5-5(1) The C compiler should start up the CPU and bring it to `main()` as is typical in most C applications.
- L5-5(2) `main()` calls `OSInit()` to initialize  $\mu$ C/OS-III. It is assumed that the statistics task is enabled by setting `OS_CFG_STAT_TASK_EN` to 1 in `OS_CFG_APP.H`. Always examine  $\mu$ C/OS-III's returned error code to make sure the call was done properly. Refer to `OS.H` for a list of possible errors, `OS_ERR_???`.
- L5-5(3) As the comment indicates, creates a single task called `AppTaskStart()` in the example (its name is left to the creator's discretion). When creating this task, give it a fairly high priority (do not use priority 0 since it's reserved for  $\mu$ C/OS-III).

Normally,  $\mu\text{C}/\text{OS-III}$  allows the user to create as many tasks as are necessary prior to calling `OSStart()`. However, when the statistic task is used to compute overall CPU utilization, it is necessary to create only one task.

L5-5(4) Call `OSStart()` to let  $\mu\text{C}/\text{OS-III}$  start the highest-priority task which, should be `AppTaskStart()`. At this point, there should be either four or five tasks created (the timer task is optional):  $\mu\text{C}/\text{OS-III}$  creates up to four tasks (`OS_IdleTask()`, `OS_TickTask()`, `OS_StatTask()` and `OS_TaskTmr()`), and now `AppTaskStart()`.

L5-5(5) The start task should then configure and enable tick interrupts. This most likely requires that the user initialize the hardware timer used for the clock tick and have it interrupt at the rate specified by `OS_CFG_STAT_TASK_RATE` (see `OS_CFG_APP.H`). Additionally, Micrium provides sample projects that include a basic board-support package (BSP). The BSP initializes many aspects of the CPU as well as the periodic time source required by  $\mu\text{C}/\text{OS-III}$ . If available, the user may utilize BSP services by calling `BSP_Init()` from the startup task. After this point, no further time source initialization is required by the user.

L5-5(6) Call `OSStatTaskCPUUsageInit()`. This function determines the maximum value that `OSStatTaskCtr` (see `OS_IdleTask()`) can count up to for  $1/\text{OS\_CFG\_STAT\_TASK\_RATE}$  second when there are no other tasks running in the system (apart for the other  $\mu\text{C}/\text{OS-III}$  tasks). For example, if the system does not contain an application task and `OSStatTaskCtr` counts from 0 to 10,000,000 for  $1/\text{OS\_CFG\_STAT\_TASK\_RATE}$  second, when adding tasks, and the test is redone every  $1/\text{OS\_CFG\_STAT\_TASK\_RATE}$  second, the `OSStatTaskCtr` will not reach 10,000,000 and actual CPU utilization is determined as follows:

$$\text{CPU\_Utilization}_{\%} = \left( 100 - \frac{100 \times \text{OSTaskStatCtr}}{\text{OSTaskStatCtr}_{\text{Max}}} \right)$$

For example, if when redoing the test, `OSStatTaskCtr` reaches 7,500,000 the CPU is busy 25% of its time running application tasks:

$$25\% = \left( 100 - \frac{100 \times 7,500,000}{10,000,000} \right)$$



---

L5-5(7) `AppTaskStart()` can then create other application tasks as needed.

As previously described,  $\mu$ C/OS-III stores run-time statistics for a task in each task's `OS_TCB`.

`OS_StatTask()` also computes stack usage of all created tasks by calling `OSTaskStkChk()` and stores the return values of this function (free and used stack space) in the `.StkFree` and `.StkUsed` field of the task's `OS_TCB`, respectively.

#### **5-6-4 THE TIMER TASK (`OS_TmrTask()`)**

$\mu$ C/OS-III provides timer services to the application programmer. Code to handle timers is found in `OS_TMR.C`.

The timer task is optional in a  $\mu$ C/OS-III application and its presence is controlled by the compile-time configuration constant `OS_CFG_TMR_EN` defined in `OS_CFG.H`. Specifically, the code is included in the build when `OS_CFG_TMR_EN` is set to 1.

Timers are countdown counters that perform an action when the counter reaches zero. The action is provided by the user through a callback function. A callback function is a function that the user declares and that will be called when the timer expires. The callback can thus be used to turn on or off a light, a motor, or perform whatever action needed. It is important to note that the callback function is called from the context of the timer task. The application programmer may create an unlimited number of timers (limited only by the amount of available RAM). Timer management is fully described in Chapter 12, "Timer Management" on page 193 and the timer services available to the application programmer are described in Appendix A, " $\mu$ C/OS-III API Reference Manual" on page 375.

`OS_TmrTask()` is a task created by  $\mu$ C/OS-III (this assumes setting `OS_CFG_TMR_EN` to 1 in `OS_CFG.H`) and its priority is configurable by the user through  $\mu$ C/OS-III's configuration file `OS_CFG_APP.H` (see `OS_CFG_TMR_TASK_PRIO`). `OS_TmrTask()` is typically set to a medium priority.

`OS_TmrTask()` is a periodic task using the same interrupt source that was used to generate clock ticks. However, timers are generally updated at a slower rate (i.e., typically 10 Hz) and the timer tick rate is divided down in software. In other words, if the tick rate is 1000 Hz and the desired timer rate is 10 Hz, the timer task will be signaled every 100th tick interrupt as shown in Figure 5-12.

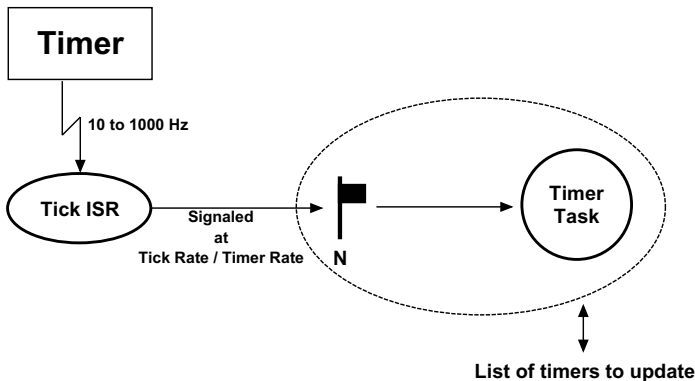

Figure 5-12 Tick ISR and Timer Task relationship

### 5-6-5 THE ISR HANDLER TASK (`OS_IntQTask()`)

When setting the compile-time configuration constant `OS_CFG_ISR_POST_DEFERRED_EN` in `OS_CFG.H` to 1,  $\mu\text{C}/\text{OS-III}$  creates a task (called `OS_IntQTask()`) responsible for “deferring” the action of OS service post calls from ISRs.

As described in Chapter 4, “Critical Sections” on page 69,  $\mu\text{C}/\text{OS-III}$  manages critical sections either by disabling/enabling interrupts, or by locking/unlocking the scheduler. If selecting the latter method (i.e., setting `OS_CFG_ISR_POST_DEFERRED_EN` to 1),  $\mu\text{C}/\text{OS-III}$  “post” functions called from interrupts are not allowed to manipulate such internal data structures as the ready list, pend lists, and others.

When an ISR calls one of the “post” functions provided by  $\mu\text{C}/\text{OS-III}$ , a copy of the data posted and the desired destination is placed in a special “holding” queue. When all nested ISRs complete,  $\mu\text{C}/\text{OS-III}$  context switches to the ISR handler task (`OS_IntQTask()`), which “re-posts” the information placed in the holding queue to the appropriate task(s). This extra step is performed to reduce the amount of interrupt disable time that would otherwise be necessary to remove tasks from wait lists, insert them in the ready list, and perform other time-consuming operations.

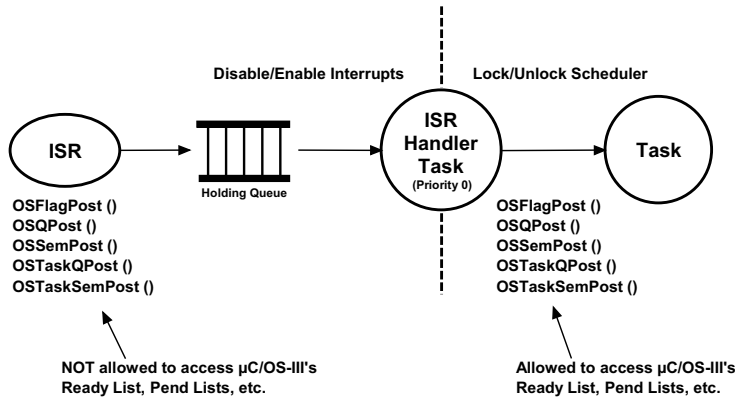

Figure 5-13 ISR Handler Task

`OS_IntQTask()` is created by  $\mu\text{C}/\text{OS-III}$  and always runs at priority 0 (i.e., the highest priority). If `OS_CFG_ISR_POST_DEFERRED_EN` is set to 1, no other task will be allowed to use priority 0.

## 5-7 SUMMARY

A task is a simple program that thinks it has the CPU all to itself. On a single CPU, only one task executes at any given time.  $\mu\text{C}/\text{OS-III}$  supports multitasking and allows the application to have any number of tasks. The maximum number of tasks is actually only limited by the amount of memory (both code and data space) available to the processor.

A task can be implemented as a run-to-completion task in which the task deletes itself when it is finished or more typically as an infinite loop, waiting for events to occur and processing those events.

A task needs to be created. When creating a task, it is necessary to specify the address of an `OS_TCB` to be used by the task, the priority of the task, and an area in RAM for the task's stack. A task can also perform computations (CPU bound task), or manage one or more I/O (Input/Output) devices.

$\mu\text{C}/\text{OS-III}$  creates up to five internal tasks: the idle task, tick task, ISR handler task, statistics task, and timer task. The idle and tick tasks are always created while statistics and timer tasks are optional.



Chapter

# 6

## The Ready List

Tasks that are ready to execute are placed in the Ready List. The ready list consists of two parts: a bitmap containing the priority levels that are ready and a table containing pointers to all the tasks ready.

## 6-1 PRIORITY LEVELS

Figures 5-1 to 5-3 show the bitmap of priorities that are ready. The “width” of the table depends on the data type `CPU_DATA` (see `CPU.H`), which can either be 8-, 16- or 32-bits. The width depends on the processor used.

$\mu$ C/OS-III allows up to `OS_CFG_PRIO_MAX` different priority levels (see `OS_CFG.H`). In  $\mu$ C/OS-III, a low-priority number corresponds to a high-priority level. Priority level zero (0) is thus the highest priority level. Priority `OS_CFG_PRIO_MAX-1` is the lowest priority level.  $\mu$ C/OS-III uniquely assigns the lowest priority to the idle task. No other tasks are allowed at this priority level. If there are tasks that are ready-to-run at a given a priority level, then its corresponding bit is set (i.e., 1) in the bitmap table. Notice in Figures 5-1 to 5-3 that “priority levels” are numbered from left to right and, the priority level increases (moves toward lower priority) with an increase in table index. The order was chosen to be able to use a special instruction called Count Leading Zeros (CLZ), which is found on many modern processors. This instruction greatly accelerates the process of determining the highest priority level.

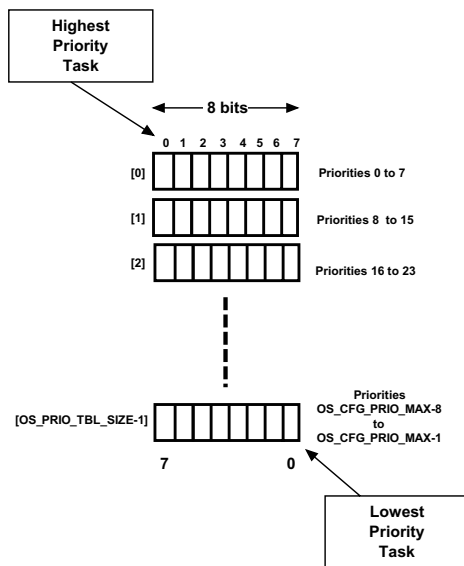

Figure 6-1 `CPU_DATA` declared as a `CPU_INT08U`

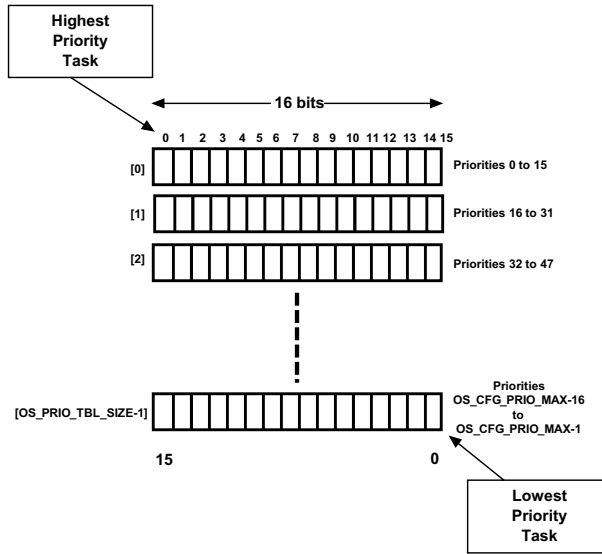

Figure 6-2 `CPU_DATA` declared as a `CPU_INT16U`

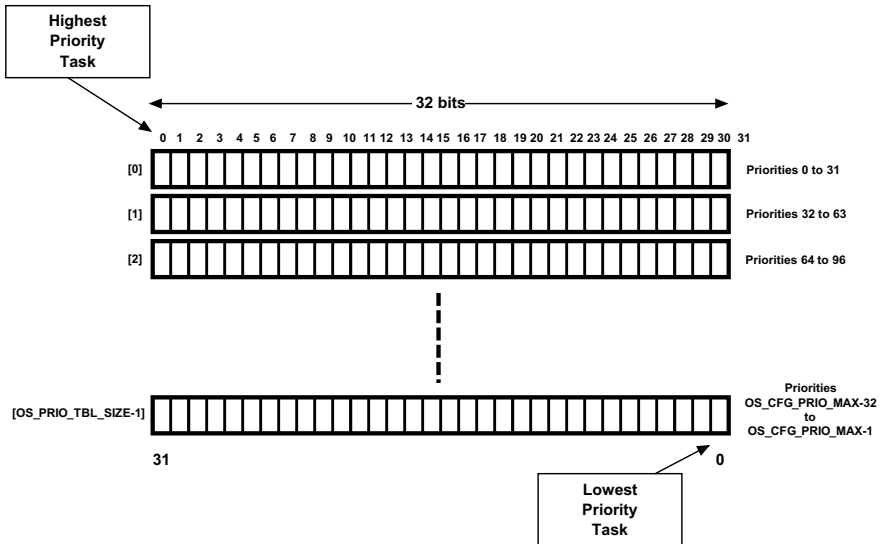

Figure 6-3 `CPU_DATA` declared as a `CPU_INT32U`

`OS_PRIO.C` contains the code to set, clear, and search the bitmap table. These functions are internal to  $\mu$ C/OS-III and are placed in `OS_PRIO.C` to allow them to be optimized in assembly language by replacing `OS_PRIO.C` with an assembly language equivalent `OS_PRIO.ASM`, when necessary.

| Function                         | Description   |
|----------------------------------|---|
| <code>OS_PrioGetHighest()</code> | Find the highest priority level                               |
| <code>OS_PrioInsert()</code>     | Set bit corresponding to priority level in the bitmap table   |
| <code>OS_PrioRemove()</code>     | Clear bit corresponding to priority level in the bitmap table |

Table 6-1 Priority Level access functions

To determine the highest priority level that contains ready-to-run tasks, the bitmap table is scanned until the first bit set in the lowest bit position is found using `OS_PrioGetHighest()`. The code for this function is shown in Listing 6-1.

```

OS_PRIO OS_PrioGetHighest (void)
{
    CPU_DATA *p_tbl;
    OS_PRIO   prio;

    prio = (OS_PRIO)0;
    p_tbl = &OSPrioTbl[0];
    while (*p_tbl == (CPU_DATA)0) {           (1)
        prio += sizeof(CPU_DATA) * 8u;      (2)
        p_tbl++;
    }
    prio += (OS_PRIO)CPU_CntLeadZeros(*p_tbl); (3)
    return (prio);
}

```

Listing 6-1 Finding the highest priority level

L6-1(1) `OS_PrioGetHighest()` scans the table from `OSPrioTbl[]` until a non-zero entry is found. The loop will always terminate because there will always be a non-zero entry in the table because of the idle task.



- L6-1(2) Each time a zero entry is found, we move to the next table entry and increment “prio” by the width (in number of bits) of each entry. If each entry is 32-bits wide, “prio” is incremented by 32.
- L6-1(3) Once the first non-zero entry is found, the number of “leading zeros” of that entry is simply added and return the priority level back to the caller. Counting the number of zeros is a CPU-specific function so that if a particular CPU has a built-in CLZ instruction, it is up to the implementer of the CPU port to take advantage of this feature. If the CPU used does not provide that instruction, the functionality must be implemented in C.

The function `CPU_CntLeadZeros()` simply counts how many zeros there are in a `CPU_DATA` entry starting from the left (i.e., most significant bit). For example, assuming 32 bits, `0xF0001234` results in 0 leading zeros and `0x00F01234` results in 8 leading zeros.

At first view, the linear path through the table might seem inefficient. However, if the number of priority levels is kept low, the search is quite fast. In fact, there are several optimizations to streamline the search. For example, if using a 32-bit processor and you are satisfied with limiting the number of different priority levels to 64, the above code can be optimized as shown in Listing 6-2. In fact, some processors have built-in “Count Leading Zeros” instructions and thus, the code can be written with just a few lines of assembly language. Remember that with  $\mu\text{C}/\text{OS-III}$ , 64 priority levels does not mean that the user is limited to 64 tasks since with  $\mu\text{C}/\text{OS-III}$ , any number of tasks are possible at a given priority level.

```
OS_PRIO OS_PrioGetHighest (void)
{
    OS_PRIO prio;

    if (OSPrioTbl[0] != (OS_PRIO_BITMAP)0) {
        prio = OS_CntLeadingZeros(OSPrioTbl[0]);
    } else {
        prio = OS_CntLeadingZeros(OSPrioTbl[1]) + 32;
    }
    return (prio);
}
```

Listing 6-2 Finding the highest priority level within 64 levels

## 6-2 THE READY LIST

Tasks that are ready to run are placed in the Ready List. As shown in Figure 6-1, the ready list is an array (`OSRdyList[]`) containing `OS_CFG_PRIO_MAX` entries, with each entry defined by the data type `OS_RDY_LIST` (see `OS.H`). An `OS_RDY_LIST` entry consists of three fields: `.Entries`, `.TailPtr` and `.HeadPtr`.

`.Entries` contains the number of ready-to-run tasks at the priority level corresponding to the entry in the ready list. `.Entries` is set to zero (0) if there are no tasks ready to run at a given priority level.

`.TailPtr` and `.HeadPtr` are used to create a doubly linked list of all the tasks that are ready at a specific priority. `.HeadPtr` points to the head of the list and `.TailPtr` points to its tail.

The “index” into the array is the priority level associated with a task. For example, if a task is created at priority level 5 then it will be inserted in the table at `OSRdyList[5]` if that task is ready to run.

Table 6-2 shows the functions that  $\mu\text{C}/\text{OS-III}$  uses to manipulate entries in the ready list. These functions are internal to  $\mu\text{C}/\text{OS-III}$  and the application code must never call them.

| Function                                | Description   |
|---|---|
| <code>OS_RdyListInit()</code>           | Initialize the ready list to “empty” (see Figure 6-4) |
| <code>OS_RdyListInsert()</code>         | Insert a TCB into the ready list                      |
| <code>OS_RdyListInsertHead()</code>     | Insert a TCB at the head of the list                  |
| <code>OS_RdyListInsertTail()</code>     | Insert a TCB at the tail of the list                  |
| <code>OS_RdyListMoveHeadToTail()</code> | Move a TCB from the head to the tail of the list      |
| <code>OS_RdyListRemove()</code>         | Remove a TCB from the ready list                      |

Table 6-2 **Ready List access functions**

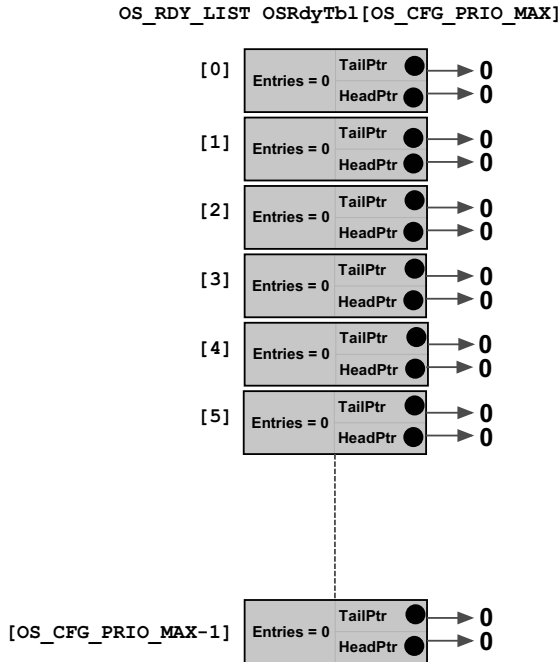

Figure 6-4 Empty Ready List

Assuming all internal  $\mu\text{C}/\text{OS-III}$ 's tasks are enabled, Figure 6-5 shows the state of the ready list after calling `OSInit()` (i.e.,  $\mu\text{C}/\text{OS-III}$ 's initialization). It is assumed that each  $\mu\text{C}/\text{OS-III}$  task had a unique priority. With  $\mu\text{C}/\text{OS-III}$ , this does not have to be the case.

- F6-4(1) There is only one entry in `OSRdyList[OS_CFG_PRIO_MAX-1]`, the idle task.
- F6-4(2) The list points to `OS_TCBs`. Only relevant fields of the TCB are shown. The `.PrevPtr` and `.NextPtr` are used to form a doubly linked list of `OS_TCBs` associated to tasks at the same priority. For the idle task, these fields always point to `NULL`.
- F6-4(3) **Priority 0** is reserved to the ISR handler task when `OS_CFG_ISR_DEFERRED_EN` is set to 1 in `OS_CFG.H`. In this case, this is the only task that can run at priority 0.

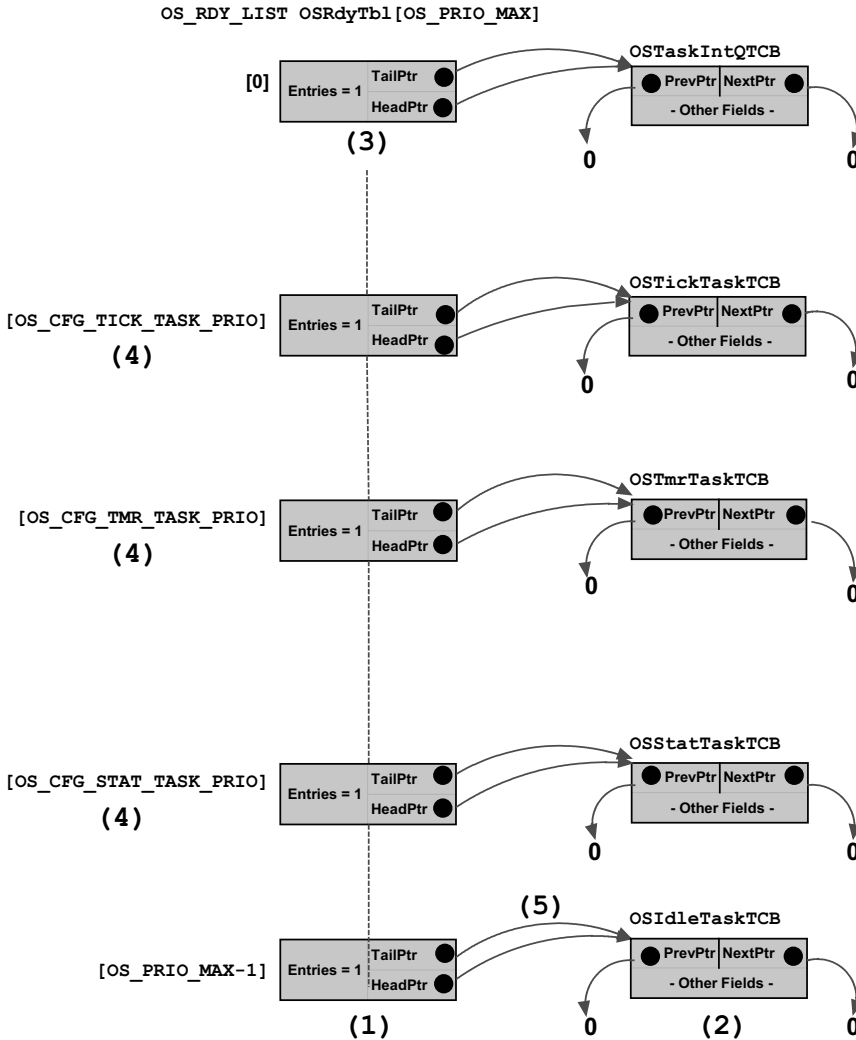

Figure 6-5 Ready List after calling OSInit()

F6-5(1) The tick task and the other two optional tasks have their own priority level, as shown.  $\mu$ C/OS-III enables the user to have multiple tasks at the same priority and thus, the tasks could be set up as shown. Typically, one would set the priority of the tick task higher than the timer task and, the timer task higher in priority than the statistic task.

F6-5(2) Both the tail and head pointers point to the same TCB when there is only one TCB at a given priority level.

### 6-3 ADDING TASKS TO THE READY LIST

Tasks are added to the ready list by a number of  $\mu\text{C}/\text{OS-III}$  services. The most obvious service is `OSTaskCreate()`, which always creates a task in the ready-to-run state and adds the task to the ready list. As shown in Figure 6-6, when creating a task, and specifying a priority level where tasks already exist (two in this example) in the ready list at that priority level, `OSTaskCreate()` will insert the new task at the end of the list of tasks at that priority level.

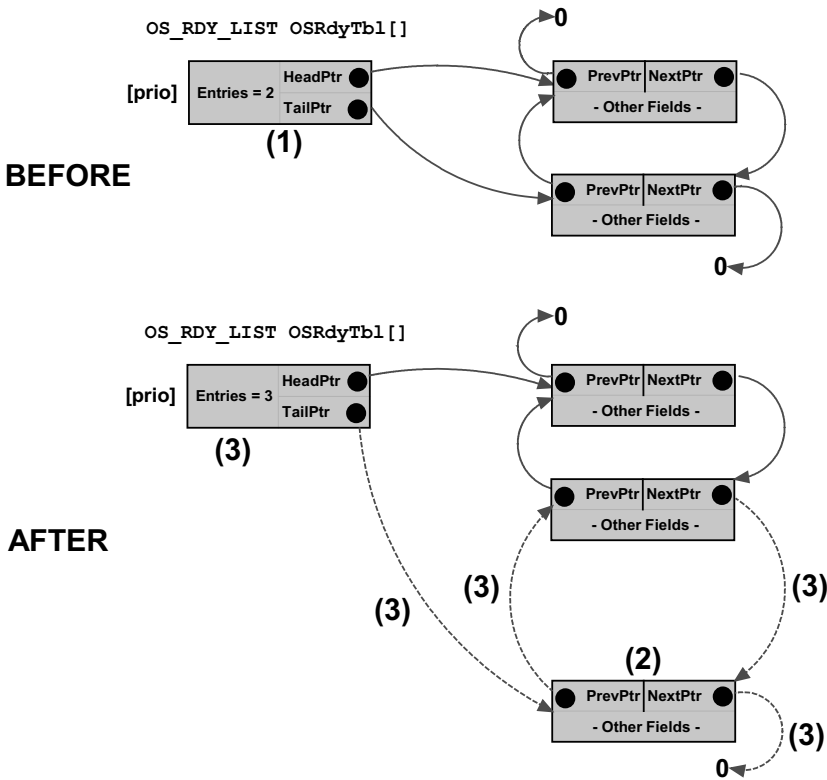

Figure 6-6 Inserting a newly created task in the ready list

F6-6(1) Before calling `OSTaskCreate()` (in this example), two tasks were in the ready list at priority “prio”.

F6-6(2) A new TCB is passed to `OSTaskCreate()` and,  $\mu\text{C}/\text{OS-III}$  initialized the contents of that TCB.

F6-6(3) `OSTaskCreate()` calls `OS_RdyListInsertTail()`, which links the new TCB to the ready list by setting up four pointers and also incrementing the `.Entries` field of `OSRdyList[prio]`. Not shown in Figure 6-6 is that `OSTaskCreate()` also calls `OS_PrioInsert()` to set the bit in the bitmap table. Of course, this operation is not necessary as there are already entries in the list at this priority. However, `OS_PrioInsert()` is a very fast call and thus it should not affect performance.

The reason the new TCB is added to the end of the list is that the current head of the list could be the task creator and, at the same priority, there is no reason to make the new task the next task to run. In fact, a task being made ready will be inserted at the tail of the list if the current task is at the same priority. However, if a task is being made ready at a different priority than the current task, it will be inserted at the head of the list.

## 6-4 SUMMARY

$\mu$ C/OS-III supports any number of different priority levels. However, 256 different priority levels should be sufficient for the most complex applications and most systems will not require more than 64 levels.

The ready list consist of two data structures: a bitmap table that keeps track of which priority level is ready, and a table containing a list of all the tasks ready at each priority level.

Processors having “count leading zeros” instructions can accelerate the table lookup process used in determining the highest priority task.

The scheduler, also called the dispatcher, is a part of  $\mu\text{C}/\text{OS-III}$  responsible for determining which task runs next.  $\mu\text{C}/\text{OS-III}$  is a *preemptive, priority-based kernel*. Each task is assigned a priority based on its importance. The priority for each task depends on the application, and  $\mu\text{C}/\text{OS-III}$  supports multiple tasks at the same priority level.

The word preemptive means that when an event occurs, and that event makes a more important task ready to run, then  $\mu\text{C}/\text{OS-III}$  will immediately give control of the CPU to that task. Thus, when a task signals or sends a message to a higher-priority task, the current task is suspended and the higher-priority task is given control of the CPU. Similarly, if an Interrupt Service Routine (ISR) signals or sends a message to a higher priority task, when the message is completed, the interrupted task remains suspended, and the new higher priority task resumes.

## 7-1 PREEMPTIVE SCHEDULING

$\mu\text{C}/\text{OS-III}$  handles event posting from interrupts using two different methods: Direct and Deferred Post. These will be discussed in greater detail in Chapter 9, “Interrupt Management” on page 157. From a scheduling point of view, the end result of the two methods is the same; the highest priority and ready task will receive the CPU as shown in Figures 6-1 and 6-2.

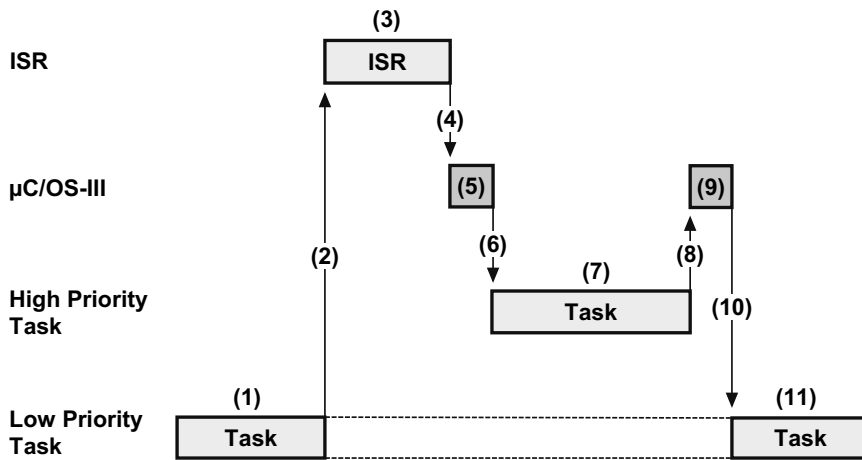

Figure 7-1 Preemptive scheduling – Direct Method

- F7-1(1) A low priority task is executing, and an interrupt occurs.
- F7-1(2) If interrupts are enabled, the CPU vectors (i.e., jumps) to the ISR that is responsible for servicing the interrupting device.
- F7-1(3) The ISR services the device and signals or sends a message to a higher-priority task waiting to service this device. This task is thus ready to run.
- F7-1(4) When the ISR completes its work it makes a service call to  $\mu\text{C}/\text{OS-III}$ .
- F7-1(5)
- F7-1(6) Since there is a more important ready-to-run task,  $\mu\text{C}/\text{OS-III}$  decides to not return to the interrupted task but switches to the more important task. See Chapter 8, “Context Switching” on page 147 for details on how this works.



F7-1(7)

F7-1(8) The higher priority task services the interrupting device and, when finished, calls  $\mu\text{C}/\text{OS-III}$  asking it to wait for another interrupt from the device.

F7-1(9)

F7-1(10)  $\mu\text{C}/\text{OS-III}$  blocks the high-priority task until the next device interrupts. Since the device has not interrupted a second time,  $\mu\text{C}/\text{OS-III}$  switches back to the original task (the one that was interrupted).

F7-1(11)

The interrupted task resumes execution, exactly at the point where it was interrupted.

Figure 7-2 shows that  $\mu\text{C}/\text{OS-III}$  performs a few extra steps when it is configured for the Deferred Post method. Notice that the end results is the same; the high-priority task preempts the low-priority one.

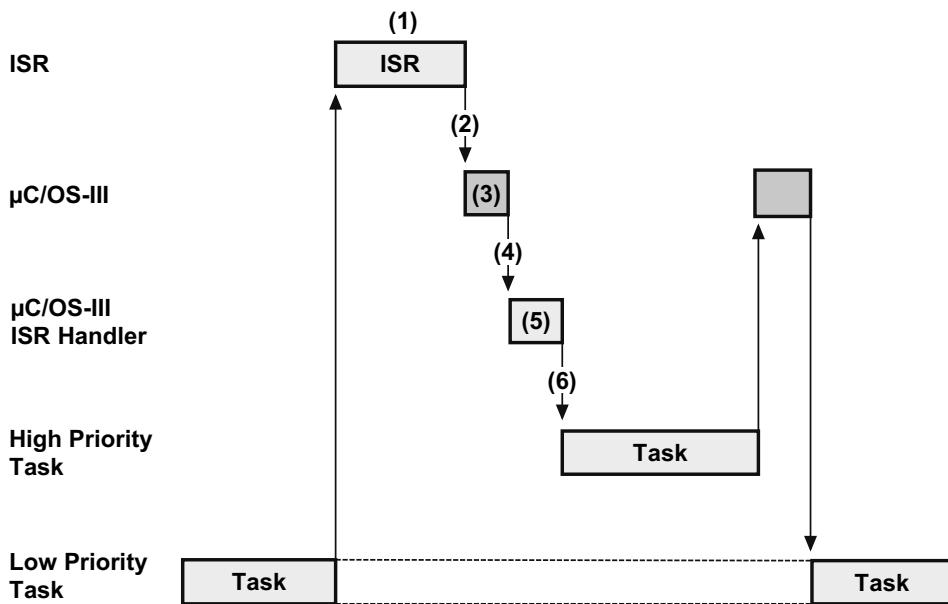

Figure 7-2 Preemptive scheduling – Deferred Post Method

- F7-2(1) The ISR services the device and, instead of signaling or sending the message to the task,  $\mu\text{C}/\text{OS-III}$  (through the `POST` call) places the post call into a special queue and makes a very high-priority task (actually the highest-possible priority) ready to run. This task is called the *ISR Handler Task*.
- F7-2(2) When the ISR completes its work, it makes a service call to  $\mu\text{C}/\text{OS-III}$ .
- F7-2(3)
- F7-2(4) Since the ISR made the ISR Handler Task ready to run,  $\mu\text{C}/\text{OS-III}$  switches to that task.
- F7-2(5)
- F7-2(6) The ISR Handler Task then removes the post call from the message queue and reissues the post. This time, however, it does it at the task level instead of the ISR level. The reason this extra step is performed is to keep interrupt disable time as small as possible. See Chapter 9, “Interrupt Management” on page 157 to find out more on the subject. When the queue is emptied,  $\mu\text{C}/\text{OS-III}$  removes the ISR Handler Task from the ready list and switches to the task that was signaled or sent a message.

## 7-2 SCHEDULING POINTS

Scheduling occurs at scheduling points and nothing special must be done in the application code since scheduling occurs automatically based on the conditions described below.

### **A task signals or sends a message to another task:**

This occurs when the task signaling or sending the message calls one of the post services, `OS???Post()`. Scheduling occurs towards the end of the `OS???Post()` call. Note that scheduling does not occur if one specifies (as part of the post call) to not invoke the scheduler (i.e., set the option argument to `OS_OPT_POST_NO_SCHED`).

### **A task calls `OSTimeDly()` or `OSTimeDlyHMSM()`:**

If the delay is non-zero, scheduling always occurs since the calling task is placed in a list waiting for time to expire. Scheduling occurs as soon as the task is inserted in the wait list.

---

**A task waits for an event to occur and the event has not yet occurred:**

This occurs when one of the `OS???``Pend()` functions are called. The task is placed in the wait list for the event and, if a non-zero timeout is specified, then the task is also inserted in the list of tasks waiting to timeout. The scheduler is then called to select the next most important task to run.

**If a task aborts a pend:**

A task is able to abort the wait (i.e., pend) of another task by calling `OS???``PendAbort()`. Scheduling occurs when the task is removed from the wait list for the specified kernel object.

**If a task is created:**

The newly created task may have a higher priority than the task's creator. In this case, the scheduler is called.

**If a task is deleted:**

When terminating a task, the scheduler is called if the current task is deleted.

**If a kernel object is deleted:**

If you delete an event flag group, a semaphore, a message queue, or a mutual exclusion semaphore, if tasks are waiting on the kernel object, those tasks will be made ready to run and the scheduler will be called to determine if any of the tasks have a higher priority than the task that deleted the kernel object.

**A task changes the priority of itself or another task:**

The scheduler is called when a task changes the priority of another task (or itself) and the new priority of that task is higher than the task that changed the priority.

**A task suspends itself by calling `OSTaskSuspend()`:**

The scheduler is called since the task that called `OSTaskSuspend()` is no longer able to execute, and must be resumed by another task.

**A task resumes another task that was suspended by `OSTaskSuspend()`:**

The scheduler is called if the resumed task has a higher priority than the task that calls `OSTaskResume()`.

**At the end of all nested ISRs:**

The scheduler is called at the end of all nested ISRs to determine whether a more important task is made ready to run by one of the ISRs. The scheduling is actually performed by `OSIntExit()` instead of `OSSched()`.

**The scheduler is unlocked by calling `OSSchedUnlock()`:**

The scheduler is unlocked after being locked. Lock the scheduler by calling `OSSchedLock()`. Note that locking the scheduler can be nested and the scheduler must be unlocked a number of times equal to the number of locks.

**A task gives up its time quanta by calling `OSSchedRoundRobinYield()`:**

This assumes that the task is running alongside with other tasks at the same priority and the currently running task decides that it can give up its time quanta and let another task run.

**The user calls `OSSched()`:**

The application code can call `OSSched()` to run the scheduler. This only makes sense if calling `OS???Post()` functions and specifying `OS_OPT_POST_NO_SCHED` so that multiple posts can be accomplished without running the scheduler on every post. Of course, in the above situation, the last post can be a post without the `OS_OPT_POST_NO_SCHED` option.

## **7-3 ROUND-ROBIN SCHEDULING**

When two or more tasks have the same priority,  $\mu\text{C}/\text{OS-III}$  allows one task to run for a predetermined amount of time (called a *Time Quanta*) before selecting another task. This process is called *Round-Robin Scheduling* or *Time Slicing*. If a task does not need to use its full time quanta it can voluntarily give up the CPU so that the next task can execute. This is called *Yielding*.  $\mu\text{C}/\text{OS-III}$  allows the user to enable or disable round robin scheduling at run time.

Figure 7-3 shows a timing diagram with tasks running at the same priority. There are three tasks that are ready to run at priority “X”. For sake of illustration, the time quanta occurs every 4th clock tick. This is shown as a darker tick mark.

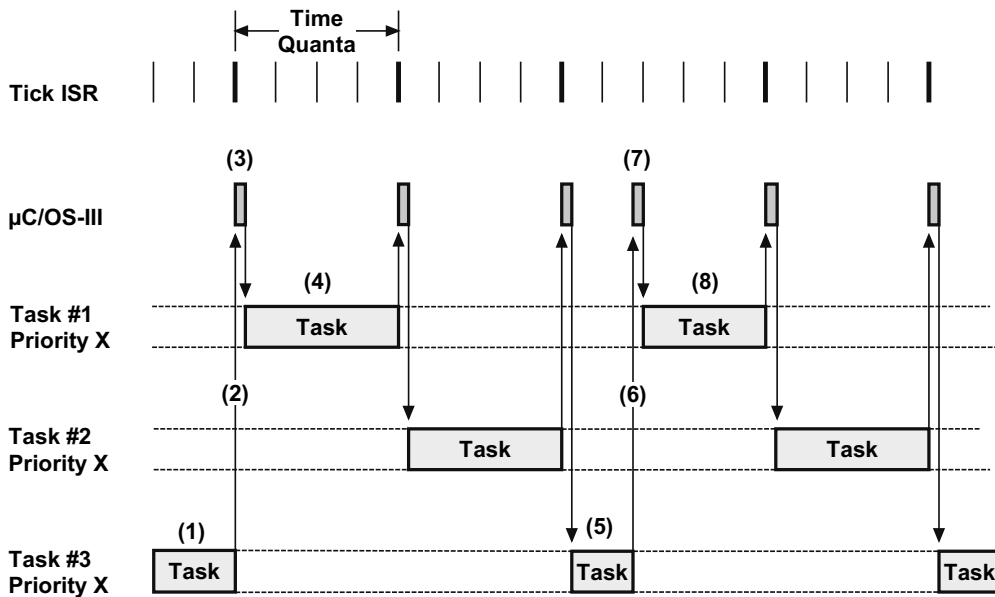

Figure 7-3 Round Robin Scheduling

- F7-3(1) Task #3 is executing. During that time, tick interrupts occur but the time quanta have not expired yet for Task #3.
- F7-3(2) On the 4th tick interrupt, the time quanta for Task #3 expire.
- F7-3(3)  $\mu\text{C}/\text{OS-III}$  resumes Task #1 since it was the next task in the list of tasks at priority “X” that was ready to run.
- F7-3(4) Task #1 executes until its time quanta expires (i.e., after four ticks).

F7-3(5)

F7-3(6)

F7-3(7) Here Task #3 executes but decides to give up its time quanta by calling the  $\mu$ C/OS-III function `OSSchedRoundRobinYield()`, which causes the next task in the list of tasks ready at priority “X” to execute. An interesting thing occurred when  $\mu$ C/OS-III scheduled Task #1. It reset the time quanta for that task to four ticks so that the next time quanta will expire four ticks from this point.

F7-3(8) Task #1 executes for its full time quanta.

$\mu$ C/OS-III allows the user to change the time quanta at run time through the `OSSchedRoundRobinCfg()` function (see Appendix A, “ $\mu$ C/OS-III API Reference Manual” on page 375). This function also allows round robin scheduling to be enabled/disabled, and the ability to change the default time quanta.

$\mu$ C/OS-III also enables the user to specify the time quanta on a per-task basis. One task could have a time quanta of 1 tick, another 12, another 3, and yet another 7, etc. The time quanta of a task is specified when the task is created. The time quanta of a task may also be changed at run time through the function `OSTaskTimeQuantaSet()`.

## 7-4 SCHEDULING INTERNALS

Scheduling is performed by two functions: `OSSched()` and `OSIntExit()`. `OSSched()` is called by task level code while `OSIntExit()` is called by ISRs. Both functions are found in `OS_CORE.C`.

Figure 7-1 illustrates the two sets of data structures that the scheduler uses; the priority ready bitmap and the ready list as described in Chapter 6, “The Ready List” on page 123.

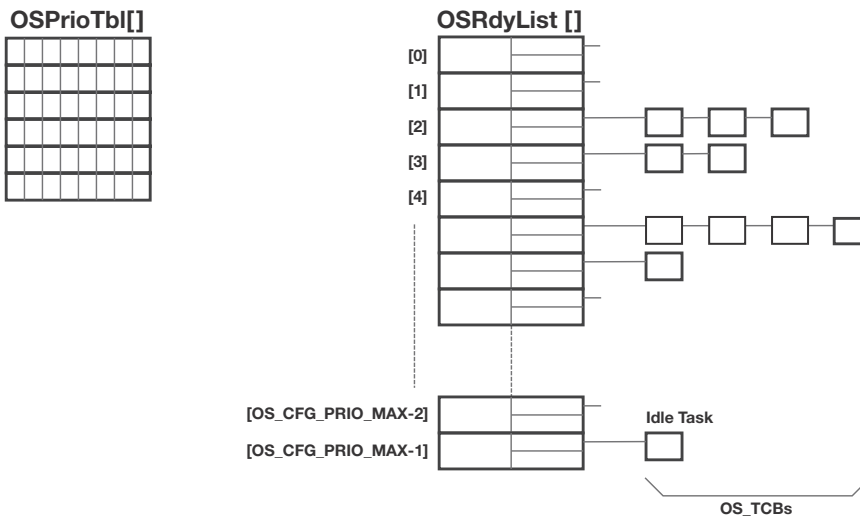

Figure 7-4 Priority ready bitmap and Ready list

### 7-4-1 OSSched()

The pseudo code for the task level scheduler, `OSSched()` is shown in Listing 7-1.

```
void OSSched (void)
{
    Disable interrupts;
    if (OSIntNestingCtr > 0) {           (1)
        return;
    }
    if (OSSchedLockNestingCtr > 0) {    (2)
        return;
    }
    Get highest priority ready;         (3)
    Get pointer to OS_TCB of next highest priority task; (4)
    if (OSTCBNHighRdyPtr != OSTCBCurPtr) { (5)
        Perform task level context switch;
    }
    Enable interrupts;
}
```

Listing 7-1 `OSSched()` pseudocode

- L7-1(1) `OSSched()` starts by making sure it is not called from an ISR as `OSSched()` is the task level scheduler. Instead, an ISR must call `OSIntExit()`. If `OSSched()` is called by an ISR, `OSSched()` simply returns.
- L7-1(2) The next step is to make sure the scheduler is not locked. If the code calls `OSSchedLock()` the user does not want to run the scheduler and the function just returns.
- L7-1(3) `OSSched()` determines the priority of the highest priority task ready by scanning the bitmap `OSPrioTbl[]` as described in Chapter 6, “The Ready List” on page 123.
- L7-1(4) Once it is known which priority is ready, index into the `OSRdyList[]` and extract the `OS_TCB` at the head of the list (i.e., `OSRdyList[highest priority].HeadPtr`). At this point, it is known which `OS_TCB` to switch to and which `OS_TCB` to save to as this was the task that called `OSSched()`. Specifically, `OSTCBCurPtr` points to the current task’s `OS_TCB` and `OSTCBHighRdyPtr` points to the new `OS_TCB` to switch to.



- L7-1(5) If the user is not attempting to switch to the same task that is currently running, `OSSched()` calls the code that will perform the context switch (see Chapter 8, “Context Switching” on page 147). As the code indicates, however, the task level scheduler calls a task-level function to perform the context switch.

Notice that the scheduler and the context switch runs with interrupts disabled. This is necessary because this process needs to be atomic.

### 7-4-2 OSIntExit()

The pseudo code for the ISR level scheduler, `OSIntExit()` is shown in Listing 7-2. Note that interrupts are assumed to be disabled when `OSIntExit()` is called.

```

void OSIntExit (void)
{
    if (OSIntNestingCtr == 0) {                (1)
        return;
    }
    OSIntNestingCtr--;
    if (OSIntNestingCtr > 0) {                (2)
        return;
    }
    if (OSSchedLockNestingCtr > 0) {          (3)
        return;
    }
    Get highest priority ready;                (4)
    Get pointer to OS_TCB of next highest priority task; (5)
    if (OSTCBHighRdyPtr != OSTCBCurPtr) {    (6)
        Perform ISR level context switch;
    }
}

```

Listing 7-2 `OSIntExit()` pseudocode

- L7-2(1) `OSIntExit()` starts by making sure that the call to `OSIntExit()` will not cause `OSIntNestingCtr` to wrap around. This would be extremely and unlikely occurrence, but not worth taking a chance that it might.
- L7-2(2) `OSIntExit()` decrements the nesting counter as `OSIntExit()` is called at the end of an ISR. If all ISRs have not nested, the code simply returns. There is no need to run the scheduler since there are still interrupts to return to.

- L7-2(3) `OSIntExit()` checks to see that the scheduler is not locked. If it is, `OSIntExit()` does not run the scheduler and simply returns to the interrupted task that locked the scheduler.
- L7-2(4) Finally, this is the last nested ISR (we are returning to task-level code) and the scheduler is not locked. Therefore, we need to find the highest priority task that needs to run.
- L7-2(5) Again, we extract the highest priority `OS_TCB` from `OSRdyList[ ]`.
- L7-2(6) If the highest-priority task is not the current task  $\mu\text{C}/\text{OS-III}$  performs an ISR level context switch. The ISR level context switch is different as it is assumed that the interrupted task's context was saved at the beginning of the ISR and it is only left to restore the context of the new task to run. This is described in Chapter 8, "Context Switching" on page 147.

### **7-4-3 OS\_SchedRoundRobin()**

When the time quanta for a task expires and there are multiple tasks at the same priority,  $\mu\text{C}/\text{OS-III}$  will select and run the next task that is ready to run at the current priority. `OS_SchedRoundRobin()` is the code used to perform this operation. `OS_SchedRoundRobin()` is either called by `OSTimeTick()` or `OS_IntQTask()`. `OS_SchedRoundRobin()` is found in `OS_CORE.C`.

`OS_SchedRoundRobin()` is called by `OSTimeTick()` when you selected the Direct Method of posting (see Chapter 9, "Interrupt Management" on page 157). `OS_SchedRoundRobin()` is called by `OS_IntQTask()` when selecting the Deferred Post Method of posting, described in Chapter 8.

The pseudo code for the round-robin scheduler is shown in Listing 7-3.

```

void OS_SchedRoundRobin (void)
{
    if (OSSchedRoundRobinEn != TRUE) {           (1)
        return;
    }
    if (Time quanta counter > 0) {               (2)
        Decrement time quanta counter;
    }
    if (Time quanta counter > 0) {
        return;
    }
    if (Number of OS_TCB at current priority level < 2) { (3)
        return;
    }
    if (OSSchedLockNestingCtr > 0) {           (4)
        return;
    }
    Move OS_TCB from head of list to tail of list; (5)
    Reload time quanta for current task;       (6)
}

```

Listing 7-3 OS\_SchedRoundRobin() pseudocode

- L7-3(1) OS\_SchedRoundRobin() starts by making sure that round robin scheduling is enabled. Recall that to enable round robin scheduling, one must call OSSchedRoundRobinCfg().
- L7-3(2) The time quanta counter, which resides inside the OS\_TCB of the running task, is decremented. If the value is still non-zero then OS\_SchedRoundRobin() returns.
- L7-3(3) Once the time quanta counter reaches zero, check to see that there are other ready-to-run tasks at the current priority. If there are none, return. Round robin scheduling only applies when there are multiple tasks at the same priority and the task doesn't completes its work within its time quanta.
- L7-3(4) OS\_SchedRoundRobin() also returns if the scheduler is locked.
- L7-3(5) Next, OS\_SchedRoundRobin() move the OS\_TCB of the current task from the head of the ready list to the end.

L7-3(6) The time quanta for the task at the head of the list are loaded. Each task may specify its own time quanta when the task is created or through `OSTaskTimeQuantaSet()`. If specifying 0,  $\mu\text{C}/\text{OS-III}$  assumes the default time quanta, which corresponds to the value in the variable `OSSchedRoundRobinDfltTimeQuanta`.

## 7-5 SUMMARY

$\mu\text{C}/\text{OS-III}$  is a preemptive scheduler so it will always execute the highest priority task that is ready to run.

$\mu\text{C}/\text{OS-III}$  allows for multiple tasks at the same priority. If there are multiple ready-to-run tasks,  $\mu\text{C}/\text{OS-III}$  will round robin between these tasks.

Scheduling occurs at specific scheduling points, when the application calls  $\mu\text{C}/\text{OS-III}$  functions.

$\mu\text{C}/\text{OS-III}$  has two schedulers: `OSSched()`, which is called by task-level code, and `OSIntExit()` called at the end of each ISR.

## Context Switching

When  $\mu\text{C}/\text{OS-III}$  decides to run a different task (see Chapter 7, “Scheduling” on page 133), it saves the current task’s context, which typically consists of the CPU registers, onto the current task’s stack and restores the context of the new task and resumes execution of that task. This process is called a *Context Switch*.

Context switching adds overhead. The more registers a CPU has, the higher the overhead. The time required to perform a context switch is generally determined by how many registers must be saved and restored by the CPU.

The context switch code is generally part of a processor’s *port* of  $\mu\text{C}/\text{OS-III}$ . A port is the code needed to adapt  $\mu\text{C}/\text{OS-III}$  to the desired processor. This code is placed in special C and assembly language files: `OS_CPU.H`, `OS_CPU_C.C` and `OS_CPU_A.ASM`. Chapter 18, “Porting  $\mu\text{C}/\text{OS-III}$ ” on page 335, Porting  $\mu\text{C}/\text{OS-III}$  provides more details on the steps needed to port  $\mu\text{C}/\text{OS-III}$  to different CPU architectures.

In this chapter, we will discuss the context switching process in generic terms using a fictitious CPU as shown in Figure 8-1. Our fictitious CPU contains 16 integer registers (R0 to R15), a separate ISR stack pointer, and a separate status register (SR). Every register is 32 bits wide and each of the 16 integer registers can hold either data or an address. The program counter (or instruction pointer) is R15 and there are two separate stack pointers labeled R14”. R14” represents a task stack pointer (TSP), and R14” represents an ISR stack pointer (ISP). The CPU automatically switches to the ISR stack when servicing an exception or interrupt. The task stack is accessible from an ISR (i.e., we can push and pop elements onto the task stack when in an ISR), and the interrupt stack is also accessible from a task.

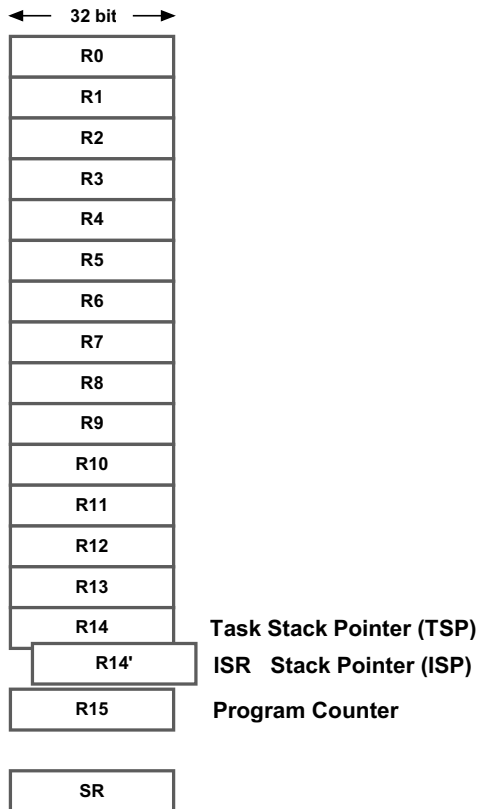

Figure 8-1 **Fictitious CPU**

In  $\mu$ C/OS-III, the stack frame for a ready task is always setup to look as if an interrupt has just occurred and all processor registers were saved onto it. Tasks enter the ready state upon creation and thus their stack frames are pre-initialized by software in a similar manner. Using our fictitious CPU, we'll assume that a stack frame for a task that is ready to be restored is shown in Figure 8-2.

The task stack pointer points to the last register saved onto the task's stack. The program counter and status registers are the first registers saved onto the stack. In fact, these are saved automatically by the CPU when an exception or interrupt occurs (assuming interrupts are enabled) while the other registers are pushed onto the stack by software in the exception handler. The stack pointer (R14) is not actually saved on the stack but instead is saved in the task's `OS_TCB`.

The interrupt stack pointer points to the current top-of-stack for the interrupt stack, which is a different memory area. When an ISR executes, the processor uses R14' as the stack pointer for function calls and local arguments.

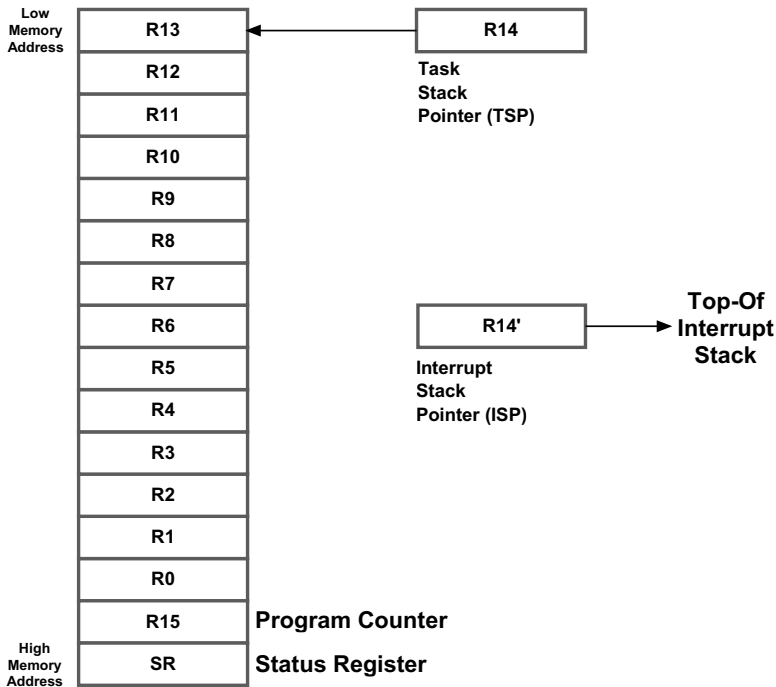

Figure 8-2 CPU register stacking order of ready task

There are two types of context switches: one performed from a task and another from an ISR. The task level context switch is implemented by the code in `OSCtxSw()`, which is actually invoked by the macro `OS_TASK_SW()`. A macro is used as there are many ways to invoke `OSCtxSw()` such as software interrupts, trap instructions, or simply calling the function.

The ISR context switch is implemented by `OSIntCtxSw()`. The code for both functions is typically written in assembly language and is found in a file called `OS_CPU_A.ASM`.

### 8-1 OSTxSw()

OSTxSw() is called when the task level scheduler (OSSched()) determines that a new high priority task needs to execute. Figure 8-3 shows the state of several  $\mu$ C/OS-III variables and data structures just prior to calling OSTxSw().

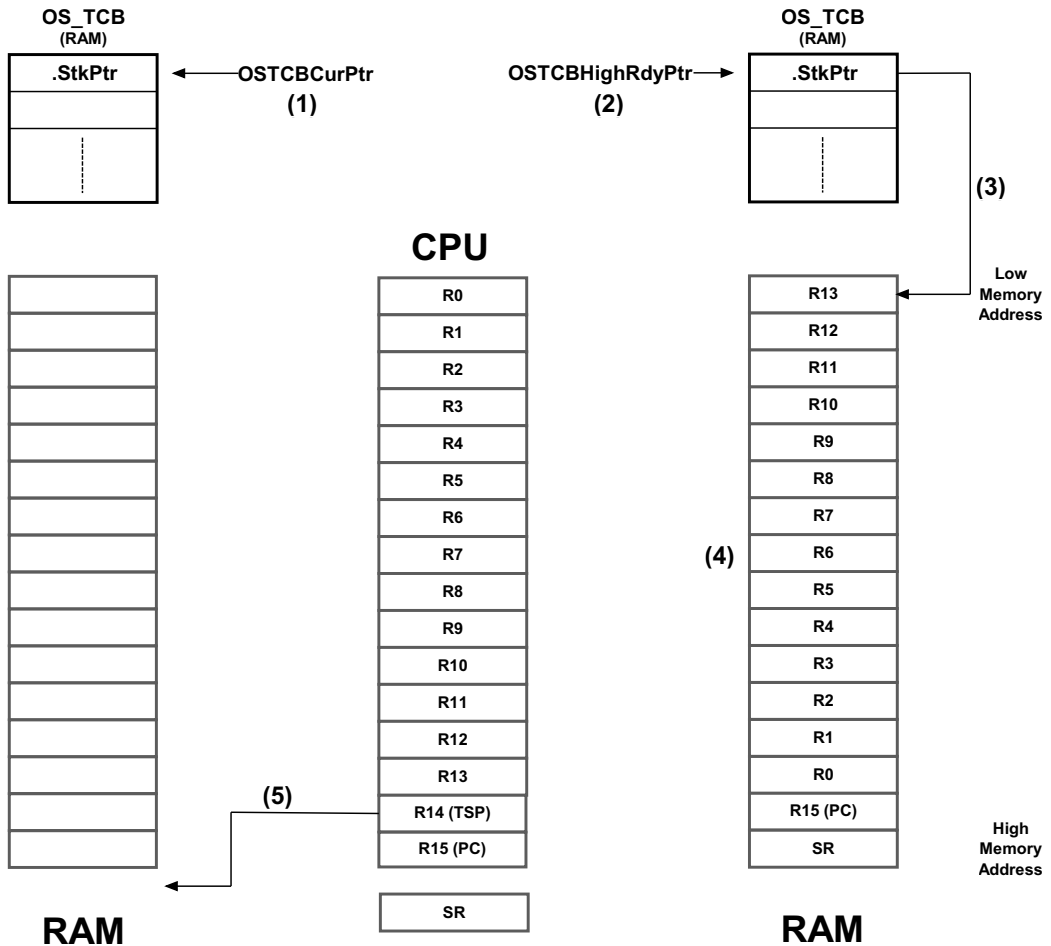

Figure 8-3 Variables and data structures prior to calling OSTxSw()

F8-3(1) OSTCBCurPtr points to the OS\_TCB of the task that is currently running and that called OSSched().

F8-3(2) OSSched() finds the new task to run by having OSTCBHighRdyPtr point to its OS\_TCB.



- F8-3(3) OSTCBHighRdyPtr→StkPtr points to the top of stack of the new task to run.
- F8-3(4) When  $\mu$ C/OS-III creates or suspends a task, it always leaves the stack frame to look as if an interrupt just occurred and all the registers saved onto it. This represents the expected state of the task so it can be resumed.
- F8-3(5) The CPU's stack pointer points within the stack area (i.e., RAM) of the task that called `OSSched()`. Depending on how `OSCtxSw()` is invoked, the stack pointer may be pointing at the return address of `OSCtxSw()`.

Figure 8-4 shows the steps involved in performing the context switch as implemented by `OSCtxSw()`.

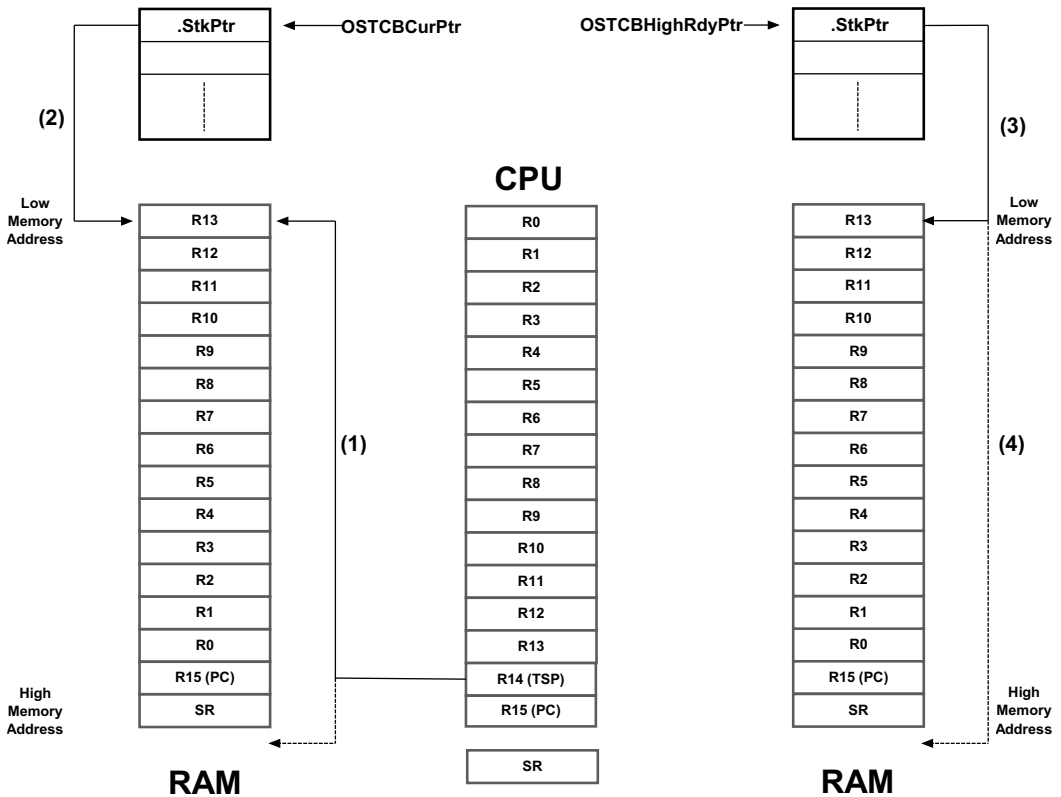

Figure 8-4 Operations performed by `OSCtxSw()`

- F8-4(1) `OSCtxSw()` begins by saving the status register and program counter of the current task onto the current task's stack. The saving order of register depends on how the CPU expects the registers on the stack frame when an interrupt occurs. In this case, it is assumed that the SR is stacked first. The remaining registers are then saved onto the stack.
- F8-4(2) `OSCtxSw()` saves the contents of the CPU's stack pointer into the `OS_TCB` of the task being suspended. In other words, `OSTCBCurPtr->StkPtr = R14`.
- F8-4(3) `OSCtxSw()` then loads the CPU stack pointer with the saved top-of-stack from the new task's `OS_TCB`. In other words, `R14 = OSTCBHighRdyPtr->StkPtr`.
- F8-4(4) Finally, `OSCtxSw()` retrieves the CPU register contents from the new stack. The program counter and status registers are generally retrieved at the same time by executing a return from interrupt instruction.

## 8-2 OSIntCtxSw()

`OSIntCtxSw()` is called when the ISR level scheduler (`OSIntExit()`) determines that a new high priority task is ready to execute. Figure 8-5 shows the state of several  $\mu\text{C}/\text{OS-III}$  variables and data structures just prior to calling `OSIntCtxSw()`.

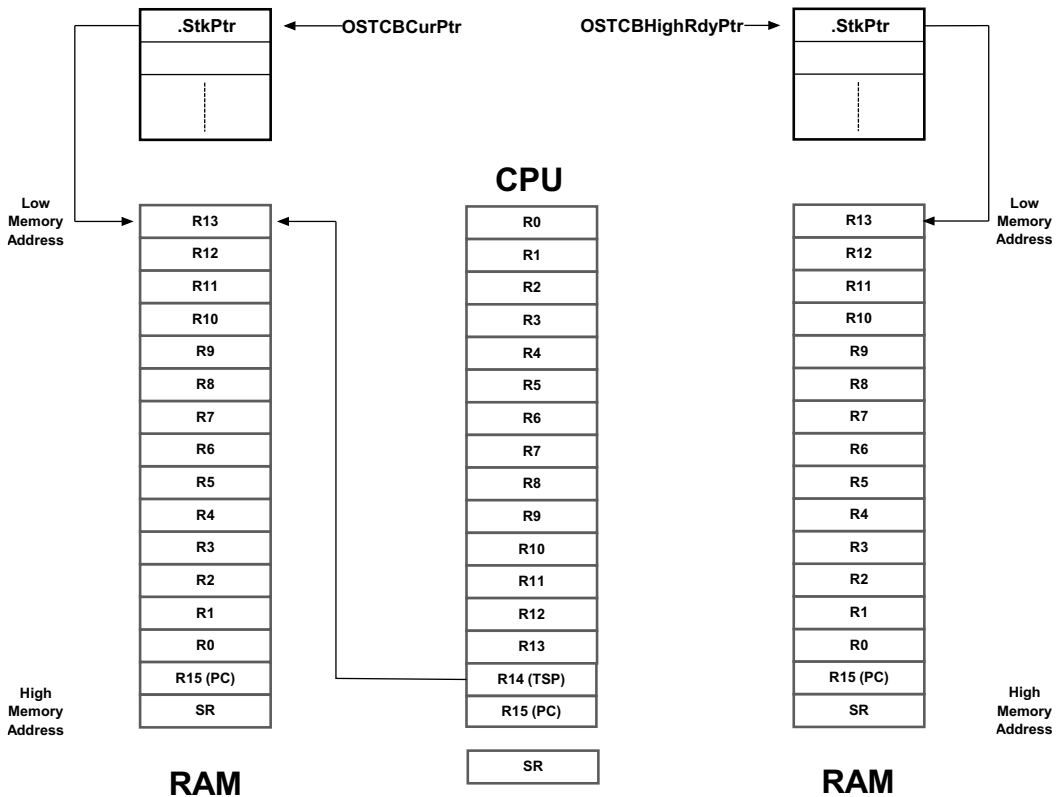

Figure 8-5 Variables and data structures prior to calling `OSIntCtxSw()`

$\mu\text{C}/\text{OS-III}$  assumes that CPU registers are saved onto the task's stack at the beginning of an ISR (see Chapter 9, "Interrupt Management" on page 157). Because of this, notice that `OSTCBCurPtr->StkPtr` contains a pointer to the top-of-stack pointer of the task being suspended (the one on the left). `OSIntCtxSw()` does not have to worry about saving the CPU registers of the suspended task since that is already finished.

Figure 8-6 shows the operations performed by `OSIntCtxSw()` to complete the second half of the context switch. This is exactly the same process as the second half of `OSCtxSw()`.

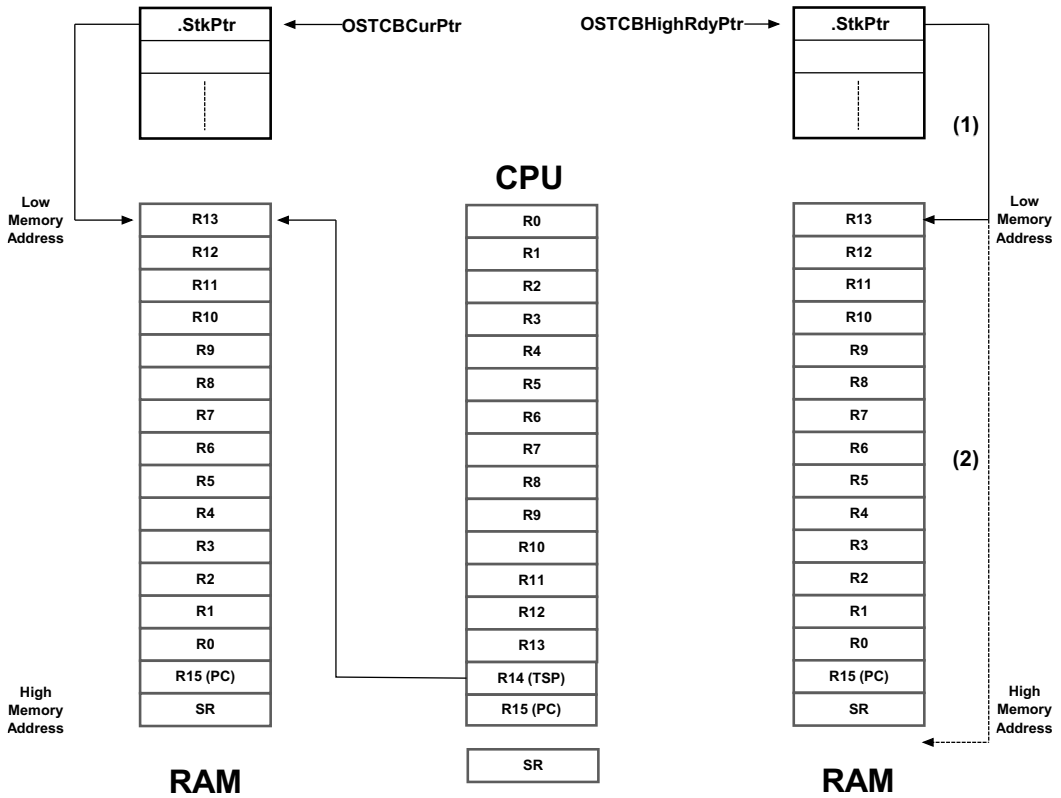

Figure 8-6 Operations performed by `OSIntCtxSw()`

F8-6(1) `OSIntCtxSw()` loads the CPU stack pointer with the saved top-of-stack from the new task's OS\_TCB. `R14 = OSTCBHighRdyPtr->StkPtr`.

F8-6(2) `OSIntCtxSw()` then retrieves the CPU register contents from the new stack. The program counter and status registers are generally retrieved at the same time by executing a return from interrupt instruction.

### **8-3 SUMMARY**

A context switch consists of saving the context (i.e., CPU registers) associated with one task and restoring the context of a new, higher-priority task.

The new task to be switched to is determined by `OSSched()` when a context switch is initiated by task level code, and `OSIntExit()` when initiated by an ISR.

`OSCtxSw()` performs the context switch for `OSSched()` and `OSIntCtxSw()` performs the context switch for `OSIntExit()`. However, `OSIntCtxSw()` only needs to perform the second half of the context switch because it is assumed that the ISR saved CPU registers upon entry to the ISR.



## Interrupt Management

An *interrupt* is a hardware mechanism used to inform the CPU that an asynchronous event occurred. When an interrupt is recognized, the CPU saves part (or all) of its context (i.e., registers) and jumps to a special subroutine called an *Interrupt Service Routine* (ISR). The ISR processes the event, and – upon completion of the ISR – the program either returns to the interrupted task, or the highest priority task, if the ISR made a higher priority task ready to run.

Interrupts allow a microprocessor to process events when they occur (i.e., asynchronously), which prevents the microprocessor from continuously *polling* (looking at) an event to see if it occurred. Task level response to events is typically better using interrupt mode as opposed to polling mode, however at the possible cost of increased interrupt latency. Microprocessors allow interrupts to be ignored or recognized through the use of two special instructions: disable interrupts and enable interrupts, respectively.

In a real-time environment, interrupts should be disabled as little as possible. Disabling interrupts affects interrupt latency possibly causing interrupts to be missed.

Processors generally allow interrupts to be nested, which means that while servicing an interrupt, the processor recognizes and services other (more important) interrupts.

One of the most important specifications of a real-time kernel is the maximum amount of time that interrupts are disabled. This is called *interrupt disable time*. All real-time systems disable interrupts to manipulate critical sections of code and re-enable interrupts when critical sections are completed. The longer interrupts are disabled, the higher the interrupt latency.

*Interrupt response* is defined as the time between the reception of the interrupt and the start of the user code that handles the interrupt. Interrupt response time accounts for the entire overhead involved in handling an interrupt. Typically, the processor's context (CPU registers) is saved on the stack before the user code is executed.

*Interrupt recovery* is defined as the time required for the processor to return to the interrupted code or to a higher priority task if the ISR made such a task ready to run.

*Task latency* is defined as the time it takes from the time the interrupt occurs to the time task level code resumes.

## 9-1 HANDLING CPU INTERRUPTS

There are many popular CPU architectures on the market today, and most processors typically handle interrupts from a multitude of sources. For example, a UART receives a character, an Ethernet controller receives a packet, a DMA controller completes a data transfer, an Analog-to-Digital Converter (ADC) completes an analog conversion, a timer expires, *etc.*

In most cases, an *interrupt controller* captures all of the different interrupts presented to the processor as shown in Figure 9-1 (note that the “CPU Interrupt Enable/Disable” is typically part of the CPU, but is shown here separately for sake of the illustration).

Interrupting devices signal the interrupt controller, which then prioritizes the interrupts and presents the highest-priority interrupt to the CPU.

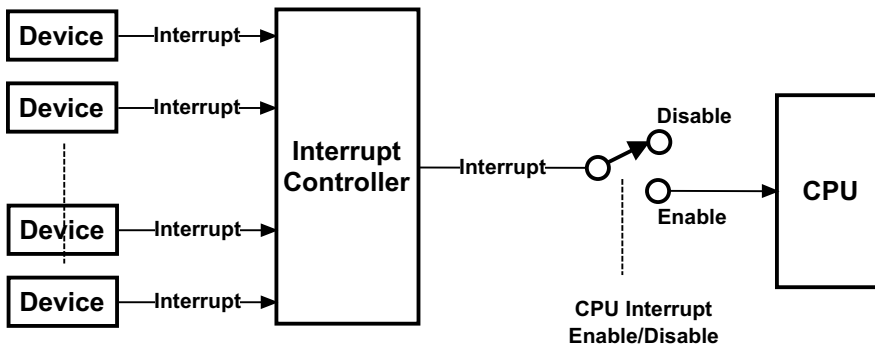

Figure 9-1 Interrupt controllers

Modern interrupt controllers have built-in intelligence that enable the user to prioritize interrupts, remember which interrupts are still pending and, in many cases, have the interrupt controller provide the address of the ISR (also called the vector address) directly to the CPU.



If “global” interrupts (i.e., the switch in Figure 9-1) are disabled, the CPU will ignore requests from the interrupt controller, but they will be held pending by the interrupt controller until the CPU re-enables interrupts.

CPUs deal with interrupts using one of two models:

- 1 All interrupts *vector* to a single interrupt handler.
- 2 Each interrupt *vectors* directly to an interrupt handler.

Before discussing these two methods, it is important to understand how  $\mu\text{C}/\text{OS-III}$  handles CPU interrupts.

## 9-2 TYPICAL $\mu\text{C}/\text{OS-III}$ INTERRUPT SERVICE ROUTINE (ISR)

$\mu\text{C}/\text{OS-III}$  requires that an interrupt service routine be written in assembly language. However, if a C compiler supports in-line assembly language, the ISR code can be placed directly into a C source file. The pseudo-code for a typical ISR when using  $\mu\text{C}/\text{OS-III}$  is shown in Listing 9-1.

```
MyISR:                                     (1)
    Disable all interrupts;                 (2)
    Save the CPU registers;                (3)
    OSIntNestingCtr++;                     (4)
    if (OSIntNestingCtr == 1) {           (5)
        OSTCBCurPtr->StkPtr = Current task's CPU stack pointer register value;
    }
    Clear interrupting device;              (6)
    Re-enable interrupts (optional);        (7)
    Call user ISR;                          (8)
    OSIntExit();                            (9)
    Restore the CPU registers;              (10)
    Return from interrupt;                  (11)
```

Listing 9-1 ISRs under  $\mu\text{C}/\text{OS-III}$  (assembly language)

L9-1(1) As mentioned above, an ISR is typically written in assembly language. **MyISR** corresponds to the name of the handler that will handle the interrupting device.

L9-1(2) It is important that all interrupts are disabled before going any further. Some processors have interrupts disabled whenever an interrupt handler starts. Others require the user to explicitly disable interrupts as shown here. This step may be tricky if a processor supports different interrupt priority levels. However, there is always a way to solve the problem.

L9-1(3) The first thing the interrupt handler must do is save the context of the CPU onto the interrupted task's stack. On some processors, this occurs automatically. However, on most processors it is important to know how to save the CPU registers onto the task's stack. Save the full "context" of the CPU, which may also include Floating-Point Unit (FPU) registers if the CPU used is equipped with an FPU.

Certain CPUs also automatically switch to a special stack just to process interrupts (i.e., an interrupt stack). This is generally beneficial as it avoids using up valuable task stack space. However, for  $\mu\text{C}/\text{OS-III}$ , the context of the interrupted task needs to be saved onto that task's stack.

If the processor does not have a dedicated stack pointer to handle ISRs then it is possible to implement one in software. Specifically, upon entering the ISR, simply save the current task stack, switch to a dedicated ISR stack, and when done with the ISR switch back to the task stack. Of course, this means that there is additional code to write, however the benefits are enormous since it is not necessary to allocate extra space on the task stacks to accommodate for worst case interrupt stack usage including interrupt nesting.

L9-1(4) Next, either call **OSIntEnter()**, or simply increment the variable **OSIntNestingCtr** in assembly language. This is generally quite easy to do and is more efficient than calling **OSIntEnter()**. As its name implies, **OSIntNestingCtr** keeps track of the interrupt nesting level.

L9-1(5) If this is the first nested interrupt, save the current value of the stack pointer of the interrupted task into its **OS\_TCB**. The global pointer **OSTCBCurPtr** conveniently points to the interrupted task's **OS\_TCB**. The very first field in

`OS_TCB` is where the stack pointer needs to be saved. In other words, `OSTCBCurPtr->StkPtr` happens to be at offset 0 in the `OS_TCB` (this greatly simplifies assembly language).

L9-1(6) At this point, clear the interrupting device so that it does not generate another interrupt until it is ready to do so. The user does not want the device to generate the same interrupt if re-enabling interrupts (refer to the next step). However, most people defer the clearing of the source and prefer to perform the action within the user ISR handler in “C.”

L9-1(7) At this point, it is safe to re-enable interrupts if the developer wants to support nested interrupts. This step is optional.

L9-1(8) At this point, further processing can be deferred to a C function called from assembly language. This is especially useful if there is a large amount of processing to do in the ISR handler. However, as a general rule, keep the ISRs as short as possible. In fact, it is best to simply signal or send a message to a task and let the task handle the details of servicing the interrupting device.

The ISR must call one of the following functions: `OSSemPost()`, `OSTaskSemPost()`, `OSFlagPost()`, `OSQPost()` or `OSTaskQPost()`. This is necessary since the ISR will notify a task, which will service the interrupting device. These are the only functions able to be called from an ISR and they are used to signal or send a message to a task. However, if the ISR does not need to call one of these functions, consider writing the ISR as a “Short Interrupt Service Routine,” as described in the next section.

L9-1(9) When completing the ISR, the user must call `OSIntExit()` to tell  $\mu$ C/OS-III that the ISR has completed. `OSIntExit()` simply decrements `OSIntNestingCtr` and, if `OSIntNestingCtr` goes to 0, this indicates that the ISR will return to task-level code (instead of a previously interrupted ISR).  $\mu$ C/OS-III will need to determine whether there is a higher priority task that needs to run because of one of the nested ISRs. In other words, the ISR might have signaled or sent a message to a higher- priority task waiting for this signal or message. In this case,  $\mu$ C/OS-III will context switch to this higher priority task instead of returning to the interrupted task. In this latter case, `OSIntExit()` does not actually return, but takes a different path.

L9-1(10) If the ISR signaled or sent a message to a lower-priority task than the interrupted task, `OSIntExit()` returns. This means that the interrupted task is still the highest-priority task to run and it is important to restore the previously saved registers.

L9-1(11) The ISR performs a return from interrupts and so resumes the interrupted task.

NOTE: From this point on, (1) to (6) will be referred to as the *ISR Prologue* and (9) to (11) as the *ISR Epilogue*.

### 9-3 SHORT INTERRUPT SERVICE ROUTINE (ISR)

The above sequence assumes that the ISR signals or sends a message to a task. However, in many cases, the ISR may not need to notify a task and can simply perform all of its work within the ISR (assuming it can be done quickly). In this case, the ISR will appear as shown in Listing 9-2.

```
MyShortISR:                                     (1)
    Save enough registers as needed by the ISR;   (2)
    Clear interrupting device;                   (3)
    DO NOT re-enable interrupts;                 (4)
    Call user ISR;                               (5)
    Restore the saved CPU registers;             (6)
    Return from interrupt;                       (7)
```

Listing 9-2 Short ISRs with  $\mu\text{C}/\text{OS-III}$

L9-2(1) As mentioned above, an ISR is typically written in assembly language. `MyShortISR` corresponds to the name of the handler that will handle the interrupting device.

L9-2(2) Here, save sufficient registers as required to handle the ISR.

L9-2(3) The user may want to clear the interrupting device to prevent it from generating the same interrupt once the ISR returns.

- 
- L9-2(4)     *Do not* re-enable interrupts at this point since another interrupt could make  $\mu\text{C}/\text{OS-III}$  calls, forcing a context switch to a higher-priority task. This means that the above ISR would complete, but at a much later time.
- L9-2(5)     Now take care of the interrupting device in assembly language or call a C function, if necessary.
- L9-2(6)     Once finished, simply restore the saved CPU registers.
- L9-2(7)     Perform a return from interrupt to resume the interrupted task.

Short ISRs, as described above, should be the exception and not the rule since  $\mu\text{C}/\text{OS-III}$  has no way of knowing when these ISRs occur.

## 9-4 ALL INTERRUPTS VECTOR TO A COMMON LOCATION

Even though an interrupt controller is present in most designs, some CPUs still vector to a common interrupt handler, and an ISR queries the interrupt controller to determine the source of the interrupt. At first glance, this might seem silly since most interrupt controllers are able to force the CPU to jump directly to the proper interrupt handler. It turns out, however, that for  $\mu\text{C}/\text{OS-III}$ , it is easier to have the interrupt controller vector to a single ISR handler than to vector to a unique ISR handler for each source. Listing 9-3 describes the sequence of events to be performed when the interrupt controller forces the CPU to vector to a single location.

```
An interrupt occurs;                               (1)
The CPU vectors to a common location;               (2)
The ISR code performs the "ISR prologue"           (3)
The C handler performs the following:              (4)
    while (there are still interrupts to process) { (5)
        Get vector address from interrupt controller;
        Call interrupt handler;
    }
The "ISR epilogue" is executed;                     (6)
```

Listing 9-3 Single interrupt vector for all interrupts

- L9-3(1) An interrupt occurs from any device. The interrupt controller activates the interrupt pin on the CPU. If there are other interrupts that occur after the first one, the interrupt controller will latch them and properly prioritize the interrupts.
- L9-3(2) The CPU vectors to a single interrupt handler address. In other words, all interrupts are to be handled by this one interrupt handler.
- L9-3(3) Execute the “ISR prologue” code needed by  $\mu\text{C}/\text{OS-III}$ . as previously described. This ensures that all ISRs will be able to make  $\mu\text{C}/\text{OS-III}$  “post” calls.
- L9-3(4) Call a  $\mu\text{C}/\text{OS-III}$  C handler, which will continue processing the ISR. This makes the code easier to write (and read). Notice that interrupts are not re-enabled.
- L9-3(5) The  $\mu\text{C}/\text{OS-III}$  C handler then interrogates the interrupt controller and asks it: “Who caused the interrupt?” The interrupt controller will either respond with a number (1 to N) or with the address of the interrupt handler for the interrupting device. Of course, the  $\mu\text{C}/\text{OS-III}$  C handler will know how to handle the specific interrupt controller since the C handler is written specifically for that controller.

If the interrupt controller provides a number between 1 and N, the C handler simply uses this number as an index into a table (in ROM or RAM) containing the address of the interrupt service routine servicing the interrupting device. A RAM table is handy to change interrupt handlers at run-time. For many embedded systems, however, the table may also reside in ROM.

If the interrupt controller responds with the address of the interrupt service routine, the C handler only needs to call this function.

In both of the above cases, all interrupt handlers need to be declared as follows:

```
void MyISRHandler (void);
```

There is one such handler for each possible interrupt source (obviously, each having a unique name).

The “while” loop terminates when there are no other interrupting devices to service.

L9-3(6) The  $\mu\text{C}/\text{OS-III}$  “ISR epilogue” is executed to see if it is necessary to return to the interrupted task, or switch to a more important one.

A couple of interesting points to notice:

- If another device caused an interrupt before the C handler had a chance to query the interrupt controller, most likely the interrupt controller will capture that interrupt. In fact, if that second device happens to be a higher-priority interrupting device, it will most likely be serviced first, as the interrupt controller will prioritize the interrupts.
- The loop will not terminate until all pending interrupts are serviced. This is similar to allowing nested interrupts, but better, since it is not necessary to redo the ISR prologue and epilogue.

The disadvantage of this method is that a high priority interrupt that occurs after the servicing of another interrupt that has already started must wait for that interrupt to complete before it will be serviced. So, the latency of any interrupt, regardless of priority, can be as long as it takes to process the longest interrupt.

## **9-5 EVERY INTERRUPT VECTORS TO A UNIQUE LOCATION**

If the interrupt controller vectors directly to the appropriate interrupt handler, each of the ISRs must be written in assembly language as described in section 9-2 “Typical  $\mu\text{C}/\text{OS-III}$  Interrupt Service Routine (ISR)” on page 159. This, of course, slightly complicates the design. However, copy and paste the majority of the code from one handler to the other and just change what is specific to the actual device.

If the interrupt controller allows the user to query it for the source of the interrupt, it may be possible to simulate the mode in which all interrupts vector to the same location by simply setting all vectors to point to the same location. Most interrupt controllers that vector to a unique location, however, do not allow users to query it for the source of the interrupt since, by definition, having a unique vector for all interrupting devices should not be necessary.

## 9-6 DIRECT AND DEFERRED POST METHODS

$\mu\text{C}/\text{OS-III}$  handles event posting from interrupts using two different methods: Direct and Deferred Post. The method used in the application is selected by changing the value of `OS_CFG_ISR_POST_DEFERRED_EN` in `OS_CFG.H` (this assumes you have access to  $\mu\text{C}/\text{OS-III}$ 's source code). When set to 0,  $\mu\text{C}/\text{OS-III}$  uses the Direct Post Method and when set to 1,  $\mu\text{C}/\text{OS-III}$  uses the Deferred Post Method.

As far as application code and ISRs are concerned, these two methods are completely transparent. It is not necessary to change anything except the configuration value `OS_CFG_ISR_POST_DEFERRED_EN` to switch between the two methods. Of course, changing the configuration constant will require recompiling the product and  $\mu\text{C}/\text{OS-III}$ .

Before explaining why to use one versus the other, let us review their differences.

### 9-6-1 DIRECT POST METHOD

The Direct Post Method is used by  $\mu\text{C}/\text{OS-II}$  and is replicated in  $\mu\text{C}/\text{OS-III}$ . Figure 9-2 shows a task diagram of what takes place in a Direct Post.

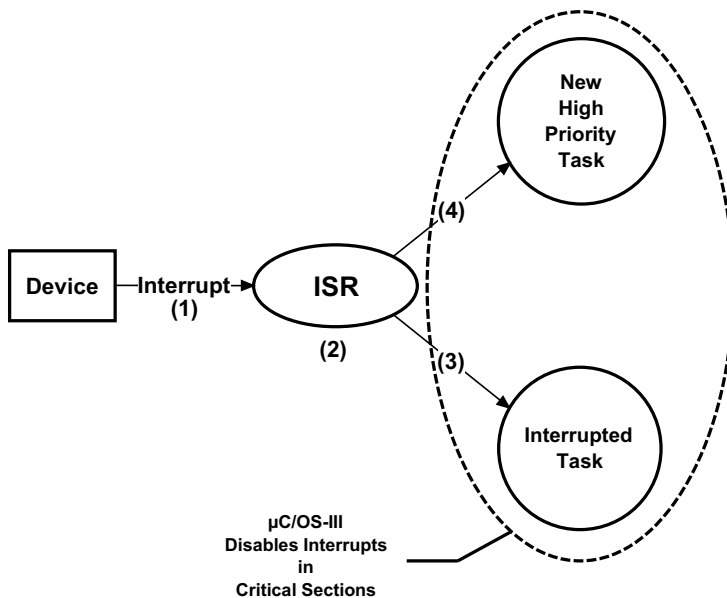

Figure 9-2 Direct Post Method



- F9-2(1) A device generates an interrupt.
- F9-2(2) The Interrupt Service Routine (ISR) responsible to handle the device executes (assuming interrupts are enabled). The device interrupt is generally the event a task is waiting for. The task waiting for this interrupt to occur either has a higher priority than the interrupted task, or lower (or equal) in priority.
- F9-2(3) If the ISR made a lower (or equal) priority task ready to run then upon completion of the ISR,  $\mu\text{C}/\text{OS-III}$  returns to the interrupted task exactly at the point the interrupt occurred.
- F9-2(4) If the ISR made a higher priority task ready to run,  $\mu\text{C}/\text{OS-III}$  will context switch to the new higher-priority task since the more important task was waiting for this device interrupt.
- F9-2(5) In the Direct Post Method,  $\mu\text{C}/\text{OS-III}$  must protect critical sections by disabling interrupts as some of these critical sections can be accessed by ISRs.

The above discussion assumed that interrupts were enabled and that the ISR could respond quickly to the interrupting device. However, if the application code makes  $\mu\text{C}/\text{OS-III}$  service calls (and it will at some point), it is possible that interrupts would be disabled. When `OS_CFG_ISR_POST_DEFERRED_EN` is set to 0,  $\mu\text{C}/\text{OS-III}$  disables interrupts while accessing critical sections. Thus, interrupts will not be responded to until  $\mu\text{C}/\text{OS-III}$  re-enables interrupts. Of course, attempts were made to keep interrupt disable times as short as possible, but there are complex features of  $\mu\text{C}/\text{OS-III}$  that disable interrupts for a longer period than the user would like.

The key factor in determining whether to use the Direct Post Method is generally the  $\mu\text{C}/\text{OS-III}$  interrupt disable time. This is fairly easy to determine since the  $\mu\text{C}/\text{CPU}$  files provided with the  $\mu\text{C}/\text{OS-III}$  port for the processor used includes code to measure maximum interrupt disable time. This code can be enabled (assumes you have the source code) for testing purposes and removed when ready to deploy the product. The user would typically not want to leave measurement code in production code to avoid introducing measurement artifacts. Once instrumented, let the application run for sufficiently long and read the variable `CPU_IntDisMeasMaxRaw_cnts`. The resolution (in time) of this variable depends on the timer used during the measurement.

Determine the interrupt latency, interrupt response, interrupt recovery, and task latency by adding the execution times of the code involved for each, as shown below.

Interrupt Latency = Maximum interrupt disable time;

Interrupt Response = Interrupt latency  
+ Vectoring to the interrupt handler  
+ ISR prologue;

Interrupt Recovery = Handling of the interrupting device  
+ Posting a signal or a message to a task  
+ `OSIntExit()`  
+ `OSIntCtxSw()`;

Task Latency = Interrupt response  
+ Interrupt recovery  
+ Time scheduler is locked;

The execution times of the  $\mu$ C/OS-III ISR prologue, ISR epilogue, `OSIntExit()`, and `OSIntCtxSw()`, can be measured independently and should be fairly constant.

It should also be easy to measure the execution time of a post call by using `OS_TS_GET()`.

In the Direct Post Method, the scheduler is locked only when handling timers and therefore, task latency should be fast if there are not too many timers with short callbacks expiring at the same time. See Chapter 12, “Timer Management” on page 193.  $\mu$ C/OS-III is also able to measure the amount of time the scheduler is locked, providing task latency.

## 9-6-2 DEFERRED POST METHOD

In the Deferred Post Method (`OS_CFG_ISR_POST_DEFERRED_EN` is set to 1), instead of disabling interrupts to access critical sections,  $\mu\text{C}/\text{OS-III}$  locks the scheduler. This avoids having other tasks access critical sections while allowing interrupts to be recognized and serviced. In the Deferred Post Method, interrupts are almost never disabled. The Deferred Post Method is, however, a bit more complex as shown in Figure 9-3.

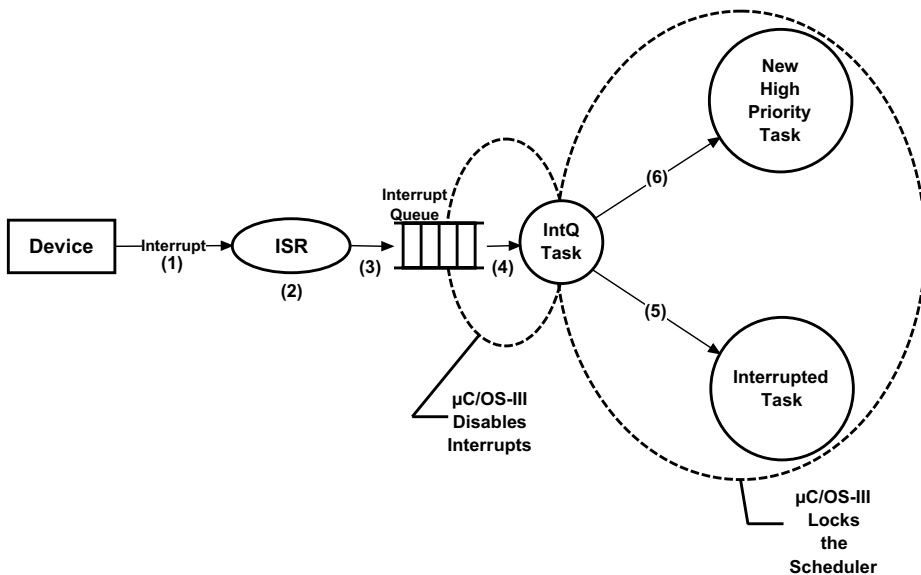

Figure 9-3 **Deferred Post Method block diagram**

- F9-3(1) A device generates an interrupt.
- F9-3(2) The ISR responsible for handling the device executes (assuming interrupts are enabled). The device interrupt is the event that a task was waiting for. The task waiting for this interrupt to occur is either higher in priority than the interrupted task, lower, or equal in priority.
- F9-3(3) The ISR calls one of the post services to signal or send a message to a task. However, instead of performing the post operation, the ISR queues the actual post call along with arguments in a special queue called the *Interrupt Queue*. The ISR then makes the *Interrupt Queue Handler Task* ready to run. This task is internal to  $\mu\text{C}/\text{OS-III}$  and is always the highest priority task (i.e., Priority 0).

- F9-3(4) At the end of the ISR,  $\mu\text{C}/\text{OS-III}$  always context switches to the interrupt queue handler task, which then extracts the post command from the queue. We disable interrupts to prevent another interrupt from accessing the interrupt queue while the queue is being emptied. The task then re-enables interrupts, locks the scheduler, and performs the post call as if the post was performed at the task level all along. This effectively manipulates critical sections at the task level.
- F9-3(5) When the interrupt queue handler task empties the interrupt queue, it makes itself not ready to run and then calls the scheduler to determine which task must run next. If the original interrupted task is still the highest priority task,  $\mu\text{C}/\text{OS-III}$  will resume that task.
- F9-3(6) If, however, a more important task was made ready to run because of the post,  $\mu\text{C}/\text{OS-III}$  will context switch to that task.

All the extra processing is performed to avoid disabling interrupts during critical sections of code. The extra processing time only consist of copying the post call and arguments into the queue, extracting it back out of the queue, and performing an extra context switch.

Similar to the Direct Post Method, it is easy to determine interrupt latency, interrupt response, interrupt recovery, and task latency, by adding execution times of the pieces of code involved for each as shown below.

Interrupt Latency = Maximum interrupt disable time;

Interrupt Response = Interrupt latency  
+ Vectoring to the interrupt handler  
+ ISR prologue;

Interrupt Recovery = Handling of the interrupting device  
+ Posting a signal or a message to the Interrupt Queue  
+ `OSIntExit()`  
+ `OSIntCtxSw()` to Interrupt Queue Handler Task;

Task Latency = Interrupt response  
+ Interrupt recovery  
+ Re-issue the post to the object or task  
+ Context switch to task  
+ Time scheduler is locked;

The execution times of the  $\mu$ C/OS-III ISR prologue, ISR epilogue, `OSIntExit()`, and `OSIntCtxSw()`, can be measured independently and should be constant.

It should also be easy to measure the execution time of a post call by using `OS_TS_GET()`. In fact, the post calls should be short in the Deferred Post Method because it only involves copying the post call and its arguments into the interrupt queue.

The difference is that in the Deferred Post Method, interrupts are disabled for a very short amount of time and thus, the first three metrics should be fast. However, task latency is higher as  $\mu$ C/OS-III locks the scheduler to access critical sections.

## 9-7 DIRECT VS. DEFERRED POST METHOD

In the Direct Post Method,  $\mu\text{C}/\text{OS-III}$  disables interrupts to access critical sections. In comparison, while in the Deferred Post Method,  $\mu\text{C}/\text{OS-III}$  locks the scheduler to access the same critical sections.

In the Deferred Post Method,  $\mu\text{C}/\text{OS-III}$  must still disable interrupts to access the interrupt queue. However, the interrupt disable time is very short and fairly constant.

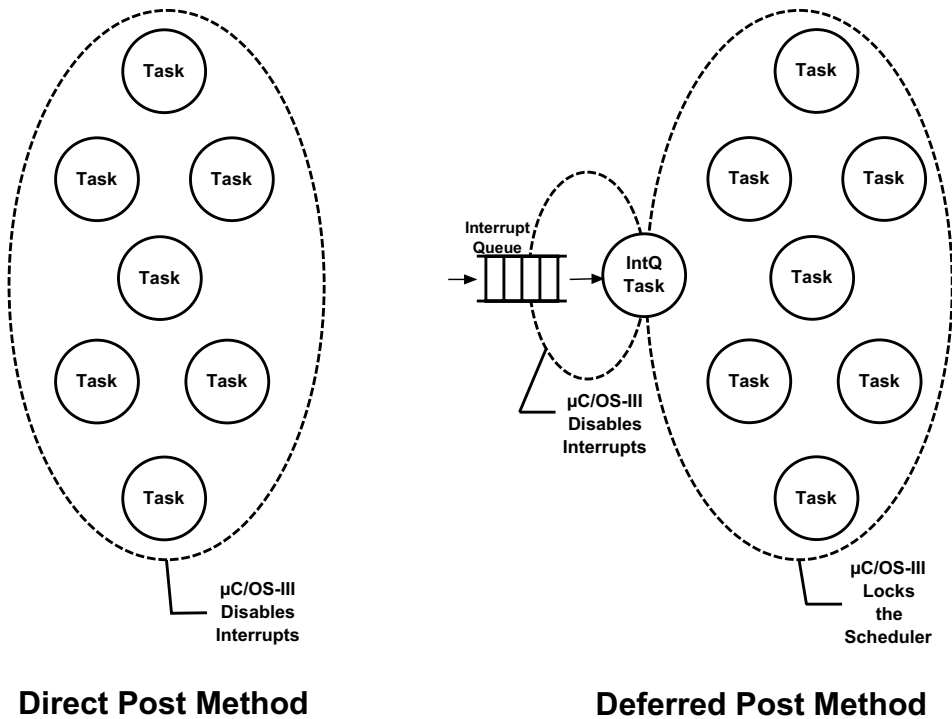

Figure 9-4 Direct vs. Deferred Post Methods

If interrupt disable time is critical in the application because there are very fast interrupt sources and the interrupt disable time of  $\mu\text{C}/\text{OS-III}$  is not acceptable using the Direct Post Method, use the Deferred Post Method.

However, if you are planning on using the features listed in Table 9-1, consider using the Deferred Post Method, described in the next section.

| Feature   | Reason   |
|---|--|
| Multiple tasks at the same priority   | Although this is an important feature of $\mu\text{C}/\text{OS-III}$ , multiple tasks at the same priority create longer critical sections. However, if there are only a few tasks at the same priority, interrupt latency will be relatively small. If the user does not create multiple tasks at the same priority, the Direct Post Method is recommended.                                 |
| Event Flags<br>Chapter 14, "Synchronization" on page 251  | If multiple tasks are waiting on different events, going through all of the tasks waiting for events requires a fair amount of processing time, which means longer critical sections. If only a few tasks (approximately one to five) are waiting on an event flag group, the critical section will be short enough to use the Direct Post Method.   |
| Pend on multiple objects<br>Chapter 16, "Pending On Multiple Objects" on page 313               | Pending on multiple objects is probably the most complex feature provided by $\mu\text{C}/\text{OS-III}$ and requires interrupts to be disabled for fairly long periods of time when using the Direct Post Method. If pending on multiple objects, the Deferred Post Method is highly recommended. If the application does not use this feature, the user may select the Direct Post Method. |
| Broadcast on Post calls<br>See <code>OSemPost()</code> and <code>OSQPost()</code> descriptions. | $\mu\text{C}/\text{OS-III}$ disables interrupts while processing a post to multiple tasks in a broadcast. If not using the broadcast option, use the Direct Post Method. Note that broadcasts only apply to semaphores and message queues.   |

Table 9-1  $\mu\text{C}/\text{OS-III}$  features to avoid when using the Direct Post Method

## 9-8 THE CLOCK TICK (OR SYSTEM TICK)

$\mu\text{C}/\text{OS-III}$ -based systems generally require the presence of a periodic time source called the *clock tick* or *system tick*.

A hardware timer configured to generate an interrupt at a rate between 10 and 1000 Hz provides the clock tick. A tick source may also be obtained by generating an interrupt from an AC power line (typically 50 or 60 Hz). In fact, one can easily derive 100 or 120 Hz by detecting zero crossings of the power line.

The clock tick interrupt can be viewed as the system's heartbeat. The rate is application specific and depends on the desired resolution of this time source. However, the faster the tick rate, the higher the overhead imposed on the system.

The clock tick interrupt allows  $\mu\text{C}/\text{OS-III}$  to delay tasks for an integral number of clock ticks and provide timeouts when tasks are waiting for events to occur.

The clock tick interrupt must call `OSTimeTick()`. The pseudocode for `OSTimeTick()` is shown in Listing 9-4.

```
void OSTimeTick (void)
{
    OSTimeTickHook();                               (1)
#ifdef OS_CFG_ISR_POST_DEFERRED_EN > 0u
    Get timestamp;                                   (2)
    Post "time tick" to the Interrupt Queue;
#else
    Signal the Tick Task;                             (3)
    Run the round-robin scheduling algorithm;         (4)
    Signal the timer task;                             (5)
#endif
}
```

Listing 9-4 `OSTimeTick()` pseudocode

L9-4(1) The time tick ISR starts by calling a hook function, `OSTimeTickHook()`. The hook function allows the implementer of the  $\mu\text{C}/\text{OS-III}$  port to perform additional processing when a tick interrupt occurs. In turn, the tick hook can call a user-defined tick hook if its corresponding pointer, `OS_AppTimeTickHookPtr`, is non-NULL. The reason the hook is called first is to give the application immediate access to this periodic time source. This can be useful to read sensors at a regular interval (not as subject to jitter), update Pulse Width Modulation (PWM) registers, and more.

L9-4(2) If  $\mu\text{C}/\text{OS-III}$  is configured for the Deferred Post Method,  $\mu\text{C}/\text{OS-III}$  reads the current timestamp and defers the call to signal the tick task by placing an appropriate entry in the interrupt queue. The tick task will thus be signaled by the Interrupt Queue Handler Task.



- L9-4(3) If  $\mu\text{C}/\text{OS-III}$  is configured for the Direct Post Method,  $\mu\text{C}/\text{OS-III}$  signals the tick task so that it can process the time delays and timeouts.
- L9-4(4)  $\mu\text{C}/\text{OS-III}$  runs the round-robin scheduling algorithm to determine whether the time slot for the current task has expired.
- L9-4(5) The tick task is also used as the time base for the timers (see Chapter 13, “Resource Management” on page 209).

A common misconception is that a system tick is always needed with  $\mu\text{C}/\text{OS-III}$ . In fact, many low-power applications may not implement the system tick because of the power required to maintain the tick list. In other words, it is not reasonable to continuously power down and power up the product just to maintain the system tick. Since  $\mu\text{C}/\text{OS-III}$  is a preemptive kernel, an event other than a tick interrupt can wake up a system placed in low power mode by either a keystroke from a keypad or other means. Not having a system tick means that the user is not allowed to use time delays and timeouts on system calls. This is a decision required to be made by the designer of the low-power product.

## **9-9 SUMMARY**

$\mu\text{C}/\text{OS-III}$  provides services to manage interrupts. An ISR should be short in length, and signal or send a message to a task, which is responsible for servicing the interrupting device.

ISRs that are short and do not need to signal or send a message to a task, are not required to do so.

$\mu\text{C}/\text{OS-III}$  supports processors that vector to a single ISR for all interrupting devices, or to a unique ISR for each device.

$\mu\text{C}/\text{OS-III}$  supports two methods: Direct and Deferred Post. The Direct Post Method assumes that  $\mu\text{C}/\text{OS-III}$  critical sections are protected by disabling interrupts. The Deferred Post Method locks the scheduler when  $\mu\text{C}/\text{OS-III}$  accesses critical sections of code.

$\mu\text{C}/\text{OS-III}$  assumes the presence of a periodic time source for applications requiring time delays and timeouts on certain services.



# Chapter 10

## Pend Lists (or Wait Lists)

A task is placed in a *Pend List* (also called a *Wait List*) when it is waiting on a semaphore to be signaled, a mutual exclusion semaphore to be released, an event flag group to be posted, or a message queue to be posted.

| <b>See ...</b>                                | <b>For ...</b>                               | <b>Kernel Object</b>  |
|---|--|-----------------------|
| Chapter 13, "Resource Management" on page 209 | Semaphores<br>Mutual Exclusion<br>Semaphores | OS_SEM<br>OS_MUTEX    |
| Chapter 14, "Synchronization" on page 251     | Semaphores<br>Event Flags                    | OS_SEM<br>OS_FLAG_GRP |
| Chapter 15, "Message Passing" on page 289     | Message Queues                               | OS_Q                  |

Table 10-1 **Kernel objects that have Pend Lists**

A pend list is similar to the *Ready List*, except that instead of keeping track of tasks that are ready-to-run, the pend list keeps track of tasks waiting for an object to be posted. In addition, the pend list is sorted by priority; the highest priority task waiting on the object is placed at the head of the list, and the lowest priority task waiting on the object is placed at the end of the list.

A pend list is a data structure of type `OS_PEND_LIST`, which consists of three fields as shown in Figure 10-1.

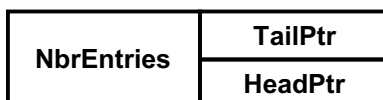

Figure 10-1 **Pend List**

- .NbrEntries**                      Contains the current number of entries in the pend list. Each entry in the pend list points to a task that is waiting for the kernel object to be posted.
  
- .TailPtr**                              Is a pointer to the last task in the list (i.e., the lowest priority task).
  
- .HeadPtr**                              Is a pointer to the first task in the list (i.e., the highest priority task).

Figure 10-2 indicates that each kernel object using a pend list contains the same three fields at the beginning of the kernel object that we called an **OS\_PEND\_OBJ**. Notice that the first field is always a “Type” which allows  $\mu\text{C}/\text{OS-III}$  to know if the kernel object is a semaphore, a mutual exclusion semaphore, an event flag group, or a message queue object.

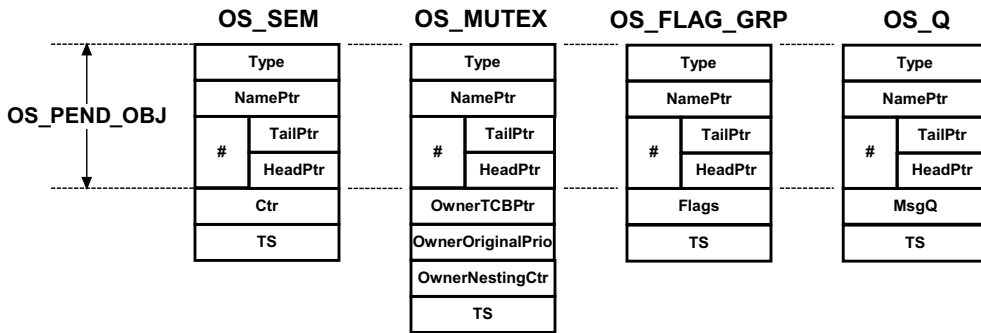

Figure 10-2 **OS\_PEND\_OBJ** at the beginning of certain kernel objects

Table 10-2 shows that the “Type” field of each of the above objects is initialized to contain four ASCII characters when the respective object is created. This allows the user to identify these objects when performing a memory dump using a debugger.

| Kernel Object              | Type            |
|----------------------------|-----------------|
| Semaphore                  | 'S' "E" "M" "A" |
| Mutual Exclusion Semaphore | 'M' "U" "T" "X" |
| Event Flag Group           | 'F' "L" "A" "G" |
| Message Queue              | 'Q' "U" "E" "U" |

Table 10-2 **Kernel objects with initialized “Type” field**

A pend list does not actually point to a task's `OS_TCB`, but instead points to `OS_PEND_DATA` objects as shown in Figure 10-3. Also, an `OS_PEND_DATA` structure is allocated dynamically on the current task's stack when a task is placed on a pend list. This implies that a task stack needs to be able to allocate storage for this data structure.

### OS\_PEND\_DATA

|            |
|------------|
| PrevPtr    |
| NextPtr    |
| TCBPtr     |
| PendObjPtr |
| RdyObjPtr  |
| RdyMsgPtr  |
| RdyMsgSize |
| RdyTS      |

Figure 10-3 **Pend Data**

- `.PrevPtr` Is a pointer to an `OS_PEND_DATA` entry in the pend list. This pointer points to a higher or equal priority task waiting on the kernel object.
- `.NextPtr` Is a pointer to an `OS_PEND_DATA` entry in the pend list. This pointer points to a lower or equal priority task waiting on the kernel object.
- `.TCBPtr` Is a pointer to the `OS_TCB` of the task waiting on the pend list.
- `.PendObjPtr` Is a pointer to the kernel object that the task is pending on. In other words, this pointer can point to an `OS_SEM`, `OS_MUTEX`, `OS_FLAG_GRP` or `OS_Q` by using an `OS_PEND_OBJ` as the common data structure.
- `.RdyObjPtr` Is a pointer to the kernel object that is ready if the task actually waits for multiple kernel objects. See Chapter 16, "Pending On Multiple Objects" on page 313 for more on this.

- .RdyMsgPtr                    Is a pointer to the message posted through OSQPost() if the task is pending on multiple kernel objects. Again, see Chapter 16, “Pending On Multiple Objects” on page 313.
  
- .RdyTS                        Is a timestamp of when the kernel object was posted. This is used when a task pends on multiple kernel objects as described in Chapter 16, “Pending On Multiple Objects” on page 313.

Figure 10-4 exhibits how all data structures connect to each other when tasks are inserted in a pend list. This drawing assumes that there are two tasks waiting on a semaphore.

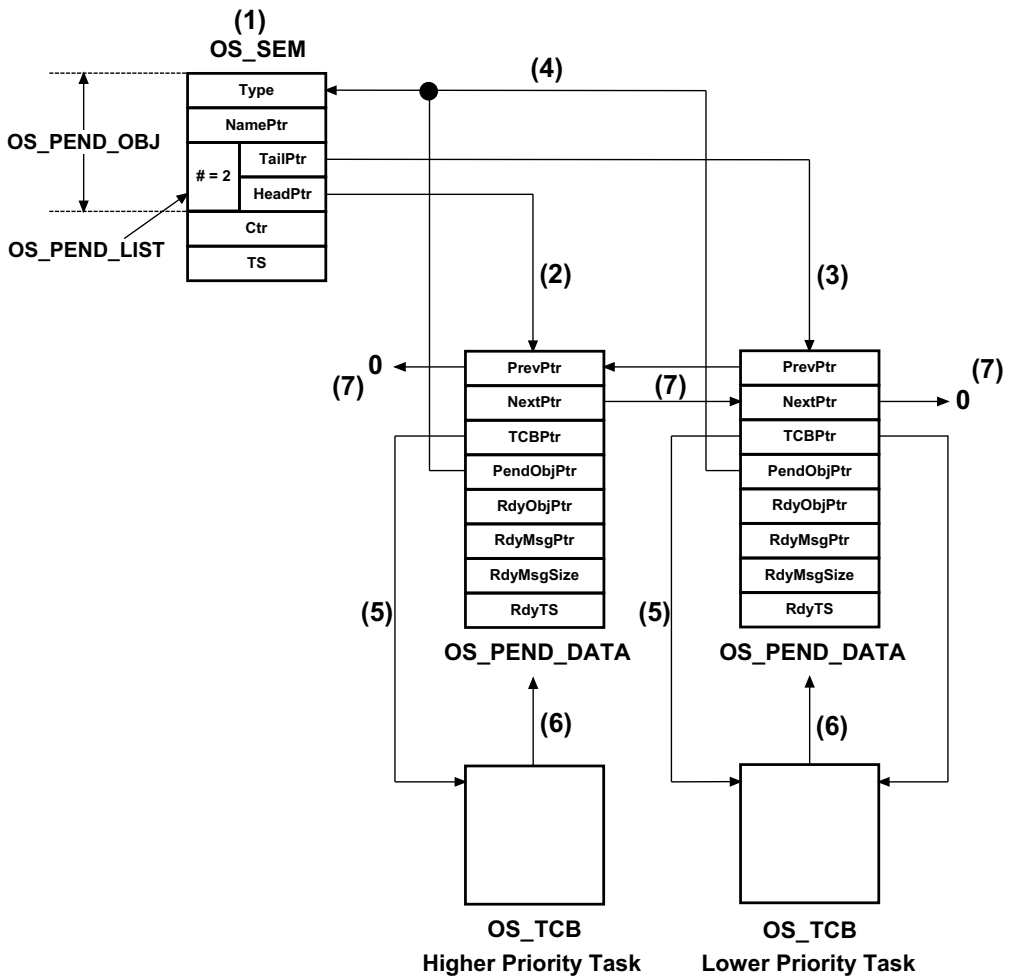

Figure 10-4 Pend Data

- F10-4(1) The `OS_SEM` data type contains an `OS_PEND_OBJ`, which in turn contains an `OS_PEND_LIST`. The `.NbrEntries` field in the pend list indicates that there are two tasks waiting on the semaphore.
- F10-4(2) The `.HeadPtr` field of the pend list points to the `OS_PEND_DATA` structure associated with the highest priority task waiting on the semaphore.
- F10-4(3) The `.TailPtr` field of the pend list points to the `OS_PEND_DATA` structure associated with the lowest priority task waiting on the semaphore.
- F10-4(4) Both `OS_PEND_DATA` structures in turn point back to the `OS_SEM` data structure. The pointers think they are pointing to an `OS_PEND_OBJ`. We know that the `OS_PEND_OBJ` is a semaphore by examining the `.Type` field of the `OS_PEND_OBJ`.
- F10-4(5) Each `OS_PEND_DATA` structure points to its respective `OS_TCB`. In other words, we know which task is pending on the semaphore.
- F10-4(6) Each task points back to the `OS_PEND_DATA` structure.
- F10-4(7) Finally, the `OS_PEND_DATA` structure forms a doubly linked list so that the  $\mu$ C/OS-III can easily add or remove entries in this list.

Although this may seem complex, the reasoning will become apparent in Chapter 16, “Pending On Multiple Objects” on page 313. For now, assume all of the links are necessary.

Table 10-3 shows the functions that  $\mu$ C/OS-III uses to manipulate entries in a pend list. These functions are internal to  $\mu$ C/OS-III and the application code must never call them. The code is found in `OS_CORE.C`.

---

| Function                | Description   |
|-------------------------|---|
| OS_PendListChangePrio() | Change the priority of a task in a pend list              |
| OS_PendListInit()       | Initialize a pend list                                    |
| OS_PendListInsertHead() | Insert an OS_PEND_DATA at the head of the pend list       |
| OS_PendListInsertPrio() | Insert an OS_PEND_DATA in priority order in the pend list |
| OS_PendListRemove()     | Remove multiple OS_PEND_DATA from the pend list           |
| OS_PendListRemove1()    | Remove single OS_PEND_DATA from the pend list             |

Table 10-3 **Pend List access functions**

## 10-1 SUMMARY

μC/OS-III keeps track of tasks waiting for semaphores, mutual exclusion semaphores, event flag groups and message queues using pend lists.

A pend list consists of a data structure of type `OS_PEND_LIST`. The pend list is further encapsulated into another data type called an `OS_PEND_OBJ`.

Tasks are not directly linked to the pend list but instead are linked through an intermediate data structure called an `OS_PEND_DATA` which is allocated on the stack of the task waiting on the kernel object.

Application code must not access pend lists, since these are internal to μC/OS-III.



## Time Management

$\mu$ C/OS-III provides time-related services to the application programmer.

In Chapter 9, “Interrupt Management” on page 157, it was established that  $\mu$ C/OS-III generally requires (as do most kernels) that the user provide a periodic interrupt to keep track of time delays and timeouts. This periodic time source is called a clock tick and should occur between 10 and 1000 times per second, or Hertz (see `OS_CFG_TICK_RATE_HZ` in `OS_CFG_APP.H`). The actual frequency of the clock tick depends on the desired tick resolution of the application. However, the higher the frequency of the ticker, the higher the overhead.

$\mu$ C/OS-III provides a number of services to manage time as summarized in Table 11-1, and the code is found in `OS_TIME.C`.

| Function Name                  | Operation  |
|--------------------------------|--|
| <code>OSTimeDly()</code>       | Delay execution of a task for “n” ticks                |
| <code>OSTimeDlyHMSM()</code>   | Delay a task for a user specified time in HH:MM:SS.mmm |
| <code>OSTimeDlyResume()</code> | Resume a delayed task                                  |
| <code>OSTimeGet()</code>       | Obtain the current value of the tick counter           |
| <code>OSTimeSet()</code>       | Set the tick counter to a new value                    |
| <code>OSTimeTick()</code>      | Signal the occurrence of a clock tick                  |

Table 11-1 **Time Services API summary**

The application programmer should refer to Appendix A, “ $\mu$ C/OS-III API Reference Manual” on page 375 for a detailed description of these services.

## 11-1 OSTimeDly()

A task calls this function to suspend execution until some time expires. The calling function will not execute until the specified time expires. This function allows three modes: relative, periodic and absolute.

Listing 11-1 shows how to use `OSTimeDly()` in relative mode.

```
void MyTask (void *p_arg)
{
    OS_ERR err;
    :
    :
    while (DEF_ON) {
        :
        :
        OSTimeDly(2,                               (1)
                 OS_OPT_TIME_DLY,                 (2)
                 &err);                             (3)
        /* Check "err" */                          (4)
        :
        :
    }
}
```

Listing 11-1 `OSTimeDly()` - Relative

- L11-1(1) The first argument specifies the amount of time delay (in number of ticks) from when the function is called. For example if the tick rate (`OS_CFG_TICK_RATE_HZ` in `OS_CFG_APP.H`) is set to 1000 Hz, the user is asking to suspend the current task for approximately 2 milliseconds. However, the value is not accurate since the count starts from the next tick which could occur almost immediately. This will be explained shortly.
- L11-1(2) Specifying `OS_OPT_TIME_DLY` indicates that the user wants to use “relative” mode.
- L11-1(3) As with most  $\mu$ C/OS-III services an error return value will be returned. The example should return `OS_ERR_NONE` as the arguments are all valid. Refer to Chapter 11, “Time Management” on page 183 for a list of possible error codes.

L11-1(4) Always check the error code returned by  $\mu\text{C}/\text{OS-III}$ . If “err” does not contain `OS_ERR_NONE`, `OSTimeDly()` did not perform the intended work. For example, another task could remove the time delay suspension by calling `OSTimeDlyResume()` and when `MyTask()` returns, it would not have returned because the time had expired.

As mentioned above, the delay is not accurate. Refer to Figure 11-1 and its description below to understand why.

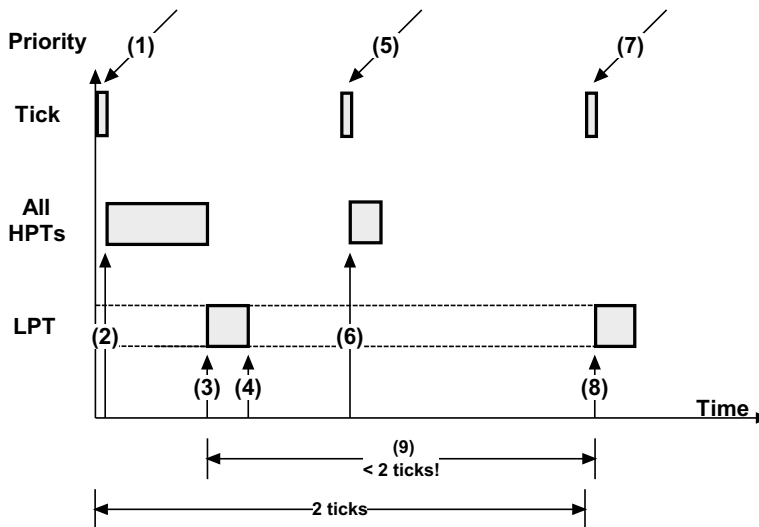

Figure 11-1 `OSTimeDly()` - Relative

- F11-1(1) We get a tick interrupt and  $\mu\text{C}/\text{OS-III}$  services the ISR.
- F11-1(2) At the end of the ISR, all Higher Priority Tasks (HPTs) execute. The execution time of HPTs is unknown and can vary.
- F11-1(3) Once all HPTs have executed,  $\mu\text{C}/\text{OS-III}$  runs the task that has called `OSTimeDly()` as shown above. For the sake of discussion, it is assumed that this task is a lower priority task (LPT).

- F11-1(4) The task calls `OSTimeDly()` and specifies to delay for two ticks in “relative” mode. At this point,  $\mu\text{C}/\text{OS-III}$  places the current task in the tick list where it will wait for two ticks to expire. The delayed task consumes zero CPU time while waiting for the time to expire.
- F11-1(5) The next tick occurs. If there are HPTs waiting for this particular tick,  $\mu\text{C}/\text{OS-III}$  will schedule them to run at the end of the ISR.
- F11-1(6) The HPTs execute.
- F11-1(7) The next tick interrupt occurs. This is the tick that the LPT was waiting for and will now be made ready to run by  $\mu\text{C}/\text{OS-III}$ .
- F11-1(8) Since there are no HPTs to execute on this tick,  $\mu\text{C}/\text{OS-III}$  switches to the LPT.
- F11-1(9) Given the execution time of the HPTs, the time delay is not exactly two ticks, as requested. In fact, it is virtually impossible to obtain a delay of exactly the desired number of ticks. One might ask for a delay of two ticks, but the very next tick could occur almost immediately after calling `OSTimeDly()`! Just imagine what might happen if all HPTs took longer to execute and pushed (3) and (4) further to the right. In this case, the delay would actually appear as one tick instead of two.

`OSTimeDly()` can also be called with the `OS_OPT_TIME_PERIODIC` option as shown in Listing 11-2. This option allows delaying the task until the tick counter reaches a certain periodic match value and thus ensures that the spacing in time is always the same as it is not subject to CPU load variations.

$\mu\text{C}/\text{OS-III}$  determines the “match value” of `OSTickCtr` to determine when the task will need to wake up based on the desired period. This is shown in Figure 11-2.  $\mu\text{C}/\text{OS-III}$  checks to ensure that if the match is computed such that it represents a value that has already gone by then, the delay will be zero.

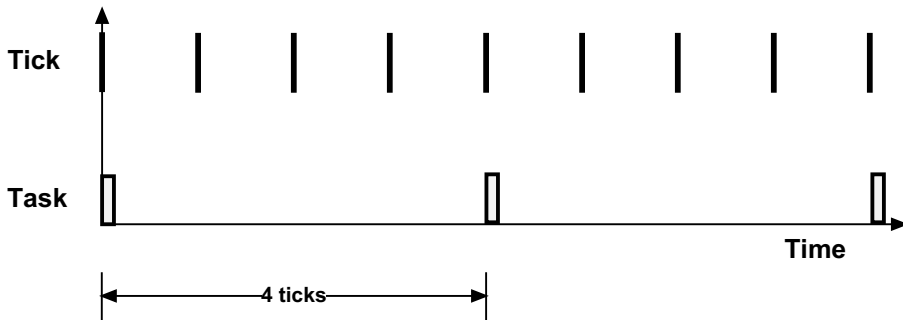
Figure 11-2 **OSTimeDly()** - Periodic

```

void MyTask (void *p_arg)
{
    OS_ERR  err;
    :
    :
    while (DEF_ON) {
        OSTimeDly(4,                (1)
                 OS_OPT_TIME_PERIODIC, (2)
                 &err);
        /* Check "err" */          (3)
        :
        :
    }
}

```

Listing 11-2 **OSTimeDly()** - Periodic

- L11-2(1) The first argument specifies the period for the task to execute, specifically every four ticks. Of course, if the task is a low-priority task,  $\mu\text{C}/\text{OS-III}$  only schedules and runs the task based on its priority relative to what else needs to be executed.
- L11-2(2) Specifying `OS_OPT_TIME_PERIODIC` indicates that the task is to be ready to run when the tick counter reaches the desired period from the previous call.
- L11-2(3) You should always check the error code returned by  $\mu\text{C}/\text{OS-III}$ .

Relative and Periodic modes might not look different, but they are. In Relative mode, it is possible to miss one of the ticks when the system is heavily loaded, missing a tick or more on occasion. In Periodic mode, the task may still execute later, but it will always be synchronized to the desired number of ticks. In fact, Periodic mode is the preferred mode to use to implement a time-of-day clock.

Finally, you can use the absolute mode to perform a specific action at a fixed time after power up. For example, turn off a light 10 seconds after the product powers up. In this case, you would specify `OS_OPT_TIME_MATCH` while “`dly`” actually corresponds to the desired value of `OSTickCtr` you want to reach.

To summarize, the task will wake up when `OSTickCtr` reaches the following value:

| Value of “opt”                    | Task wakes up when                             |
|-----------------------------------|--|
| <code>OS_OPT_TIME_DLY</code>      | <code>OSTickCtr + dly</code>                   |
| <code>OS_OPT_TIME_PERIODIC</code> | <code>OSTCBCurPtr-&gt;TickCtrPrev + dly</code> |
| <code>OS_OPT_TIME_MATCH</code>    | <code>dly</code>                               |

## 11-2 OSTimeDlyHMSM()

A task may call this function to suspend execution until some time expires by specifying the length of time in a more user-friendly way. Specifically, specify the delay in hours, minutes, seconds, and milliseconds (thus the **HMSM**). This function only works in “Relative” mode.

Listing 11-3 indicates how to use `OSTimeDlyHMSM()`.

```
void MyTask (void *p_arg)
{
    OS_ERR err;
    :
    :
    while (DEF_ON) {
        :
        :
        OSTimeDlyHMSM(0,                (1)
                    0,
                    1,
                    0,
                    OS_OPT_TIME_HMSM_STRICT, (2)
                    &err);             (3)
        /* Check "err" */
        :
        :
    }
}
```

Listing 11-3 `OSTimeDlyHMSM()`

- L11-3(1) The first four arguments specify the amount of time delay (in hours, minutes, seconds, and milliseconds) from this point in time. In the above example, the task should delay by 1 second. The resolution greatly depends on the tick rate. For example, if the tick rate (`OS_CFG_TICK_RATE_HZ` in `OS_CFG_APP.H`) is set to 1000 Hz there is technically a resolution of 1 millisecond. If the tick rate is 100 Hz then the delay of the current task is in increments of 10 milliseconds. Again, given the relative nature of this call, the actual delay may not be accurate.
- L11-3(2) Specifying `OS_OPT_TIME_HMSM_STRICT` verifies that the user strictly passes valid values for hours, minutes, seconds and milliseconds. Valid hours are 0 to 99, valid minutes are 0 to 59, valid seconds are 0 to 59, and valid milliseconds are 0 to 999.

If specifying `OS_OPT_TIME_HMSM_NON_STRICT`, the function will accept nearly any value for hours (between 0 to 999), minutes (from 0 to 9999), seconds (any value, up to 65,535), and milliseconds (any value, up to 4,294,967,295). `OSTimeDlyHMSM(203, 101, 69, 10000)` may be accepted. Whether or not this makes sense is a different story.

The reason hours is limited to 999 is that time delays typically use 32-bit values to keep track of ticks. If the tick rate is set at 1000 Hz then, it is possible to only track 4,294,967 seconds, which corresponds to 1,193 hours, and therefore 999 is a reasonable limit.

L11-3(3) As with most  $\mu$ C/OS-III services the user will receive an error return value. The example should return `OS_ERR_NONE` since the arguments are all valid. Refer to Appendix A, “ $\mu$ C/OS-III API Reference Manual” on page 375 for a list of possible error codes.

Even though  $\mu$ C/OS-III allows for very long delays for tasks, it is actually not recommended to delay tasks for a long time. There is no indication that the task is actually “alive” unless it is possible to monitor the amount of time remaining for the delay. It is better to have the task wake up approximately every minute or so, and have it “tell you” that it is still ok.

`OSTimeDly()` and `OSTimeDlyHMSM()` are often used to create periodic tasks (tasks that execute periodically). For example, it is possible to have a task that scans a keyboard every 50 milliseconds and another task that reads analog inputs every 10 milliseconds, etc.



### 11-3 OSTimeDlyResume()

A task can resume another task that called `OSTimeDly()` or `OSTimeDlyHMSM()` by calling `OSTimeDlyResume()`. Listing 11-4 shows how to use `OSTimeDlyResume()`. The task that delayed itself will not know that it was resumed, but will think that the delay expired. Because of this, use this function with great care.

```
OS_TCB MyTaskTCB;

void MyTask (void *p_arg)
{
    OS_ERR err;
    :
    :
    while (1) {
        :
        :
        OSTimeDly(10,
                 OS_OPT_TIME_DLY,
                 &err);
        /* Check "err" */
        :
        :
    }
}

void MyOtherTask (void *p_arg)
{
    OS_ERR err;
    :
    :
    while (1) {
        :
        :
        OSTimeDlyResume(&MyTaskTCB,
                       &err);
        /* Check "err" */
        :
        :
    }
}
```

Listing 11-4 `OSTimeDlyResume()`

## **11-4 OSTimeSet() AND OSTimeGet()**

$\mu$ C/OS-III increments a tick counter every time a tick interrupt occurs. This counter allows the application to make coarse time measurements and have some notion of time (after power up).

`OSTimeGet()` allows the user to take a snapshot of the tick counter. As shown in a previous section, use this value to delay a task for a specific number of ticks and repeat this periodically without losing track of time.

`OSTimeSet()` allows the user to change the current value of the tick counter. Although  $\mu$ C/OS-III allows for this, it is recommended to use this function with great care.

## **11-5 OSTimeTick()**

The tick Interrupt Service Routine (ISR) must call this function every time a tick interrupt occurs.  $\mu$ C/OS-III uses this function to update time delays and timeouts on other system calls. `OSTimeTick()` is considered an internal function to  $\mu$ C/OS-III.

## **11-6 SUMMARY**

$\mu$ C/OS-III provides services to applications so that tasks can suspend their execution for user-defined time delays. Delays are either specified by a number of clock ticks or hours, minutes, seconds, and milliseconds.

Application code can resume a delayed task by calling `OSTimeDlyResume()`. However, its use is not recommended because resumed task will not know that they were resumed as opposed to the time delay expired.

$\mu$ C/OS-III keeps track of the number of ticks occurring since power up or since the number of ticks counter was last changed by `OSTimeSet()`. The counter may be read by the application code using `OSTimeGet()`.

## Timer Management

$\mu$ C/OS-III provides timer services to the application programmer and code to handle timers is found in `OS_TMR.C`. Timer services are enabled when setting `OS_CFG_TMR_EN` to 1 in `OS_CFG.H`.

Timers are down counters that perform an *action* when the counter reaches zero. The user provides the action through a *callback* function (or simply *callback*). A callback is a user-declared function that will be called when the timer expires. The callback can be used to turn a light on or off, start a motor, or perform other actions. However, it is important to never make blocking calls within a callback function (i.e., call `OSTimeDly()`, `OSTimeDlyHMSM()`, `OS???Pend()`, or anything that causes the timer task to block or be deleted).

Timers are useful in protocol stacks (retransmission timers, for example), and can also be used to poll I/O devices at predefined intervals.

An application can have any number of timers (limited only by the amount of RAM available). Timer services in  $\mu$ C/OS-III start with the `OSTmr???` prefix, and the services available to the application programmer are described in Appendix A, “ $\mu$ C/OS-III API Reference Manual” on page 375.

The resolution of all the timers managed by  $\mu$ C/OS-III is determined by the configuration constant: `OS_CFG_TMR_TASK_RATE_HZ`, which is expressed in Hertz (Hz). So, if the timer task (described later) rate is set to 10, all timers have a resolution of 1/10th of a second (ticks in the diagrams to follow). In fact, this is the typical recommended value for the timer task. Timers are to be used with “coarse” granularity.

μC/OS-III provides a number of services to manage timers as summarized in Table 12-1.

| Function Name    | Operation  |
|------------------|--|
| OSTmrCreate()    | Create and specify the operating mode of the timer.      |
| OSTmrDel()       | Delete a timer.  |
| OSTmrRemainGet() | Obtain the remaining time left before the timer expires. |
| OSTmrStart()     | Start (or restart) a timer.                              |
| OSTmrStateGet()  | Obtain the current state of a timer.                     |
| OSTmrStop()      | Stop the countdown process of a timer.                   |

Table 12-1 **Timer API summary**

A timer needs to be created before it can be used. Create a timer by calling `OSTmrCreate()` and specify a number of arguments to this function based on how the timer is to operate. Once the timer operation is specified, its operating mode cannot be changed unless the timer is deleted and recreated. The function prototype for `OSTmrCreate()` is shown below as a quick reference:

```
void OSTmrCreate (OS_TMR          *p_tmr,           /* Pointer to timer */
                 CPU_CHAR        *p_name,         /* Name of timer, ASCII */
                 OS_TICK         dly,            /* Initial delay */
                 OS_TICK         period,        /* Repeat period */
                 OS_OPT          opt,           /* Options */
                 OS_TMR_CALLBACK_PTR p_callback, /* Fnct to call at 0 */
                 void            *p_callback_arg, /* Arg. to callback */
                 OS_ERR          *p_err)
```

Once created, a timer can be started (or restarted) and stopped as often as is necessary. Timers can be created to operate in one of three modes: One-shot, Periodic (no initial delay), and Periodic (with initial delay).

## 12-1 ONE-SHOT TIMERS

As its name implies, a one-shot timer will countdown from its initial value, call the callback function when it reaches zero, and stop. Figure 12-1 shows a timing diagram of this operation. The countdown is initiated by calling `OSTmrStart()`. At the completion of the time delay, the callback function is called, assuming a callback function was provided when the timer was created. Once completed, the timer does not do anything unless restarted by calling `OSTmrStart()`, at which point the process starts over.

Terminate the countdown process of a timer (before it reaches zero) by calling `OSTmrStop()`. In this case, specify that the callback function be called or not.

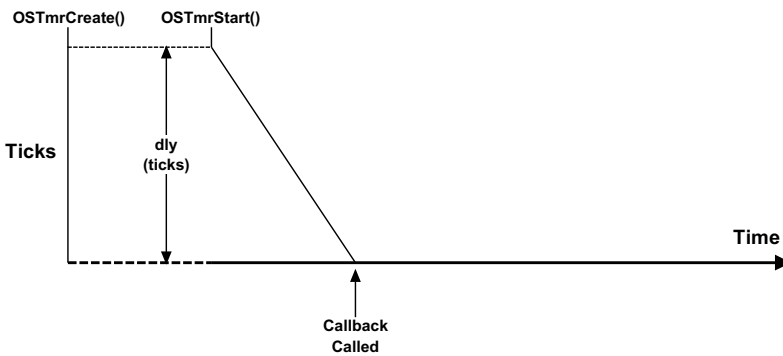

Figure 12-1 One Shot Timers ( $dly > 0$ ,  $period == 0$ )

As shown in Figure 12-2, a one-shot timer is retriggered by calling `OSTmrStart()` before the timer reaches zero. This feature can be used to implement watchdogs and similar safeguards.

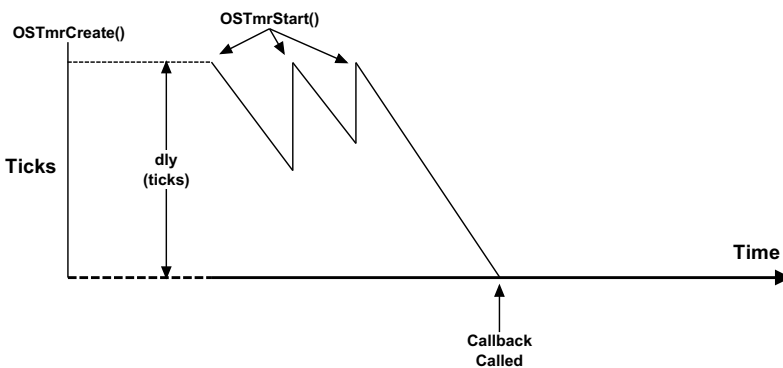

Figure 12-2 Retriggering a One Shot Timer

## 12-2 PERIODIC (NO INITIAL DELAY)

As indicated in Figure 12-3, timers can be configured for periodic mode. When the countdown expires, the callback function is called, the timer is automatically reloaded, and the process is repeated. If specifying a delay of zero (i.e., `dly == 0`) when the timer is created, when started, the timer immediately uses the “`period`” as the reload value. Calling `OSTmrStart()` at any point in the countdown restarts the process.

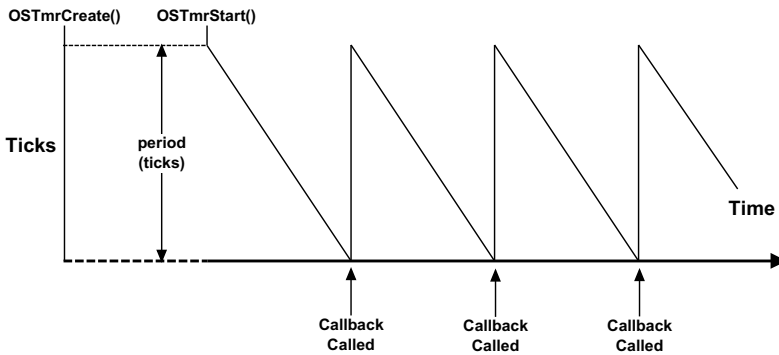

Figure 12-3 Periodic Timers (`dly == 0`, `period > 0`)

## 12-3 PERIODIC (WITH INITIAL DELAY)

As shown in Figure 12-4, timers can be configured for periodic mode with an initial delay that is different than its period. The first countdown count comes from the “`dly`” argument passed in the `OSTmrCreate()` call, and the reload value is the “`period`”. Calling `OSTmrStart()` restarts the process including the initial delay.

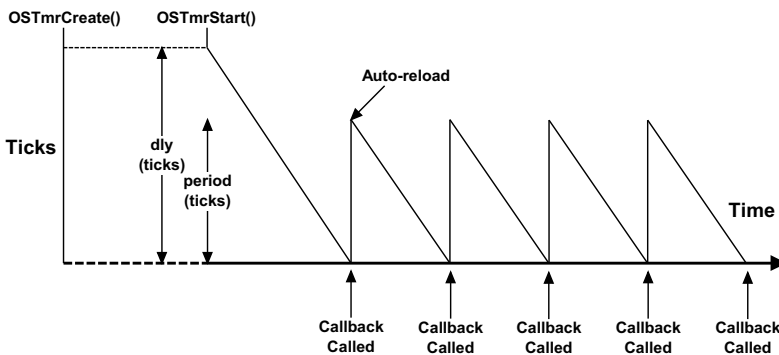

Figure 12-4 Periodic Timers (`dly > 0`, `period > 0`)

## 12-4 TIMER MANAGEMENT INTERNALS

### 12-4-1 TIMER MANAGEMENT INTERNALS - TIMERS STATES

Figure 12-5 shows the state diagram of a timer.

Tasks can call `OSTmrStateGet()` to find out the state of a timer. Also, at any time during the countdown process, the application code can call `OSTmrRemainGet()` to find out how much time remains before the timer reaches zero (0). The value returned is expressed in “timer ticks.” If timers are decremented at a rate of 10 Hz then a count of 50 corresponds to 5 seconds. If the timer is in the stop state, the time remaining will correspond to either the initial delay (one shot or periodic with initial delay), or the period if the timer is configured for periodic without initial delay.

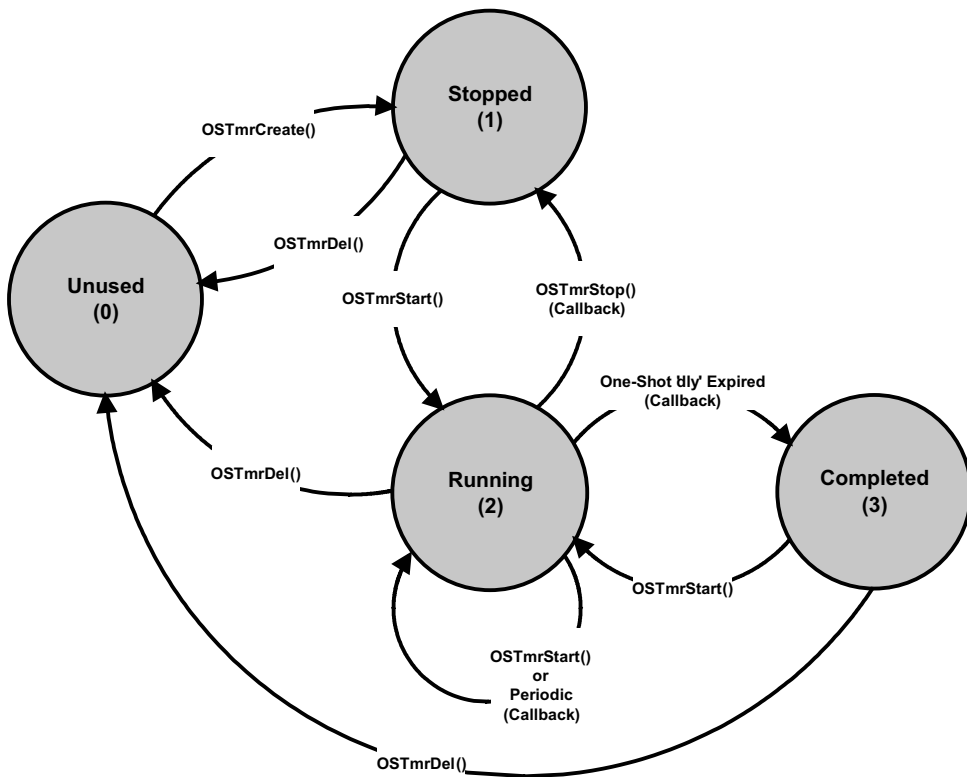

Figure 12-5 Timer State Diagram

- F12-5(1) The “Unused” state is a timer that has not been created or has been “deleted.” In other words,  $\mu\text{C}/\text{OS-III}$  does not know about this timer.
- F12-5(2) When creating a timer or calling `OSTmrStop()`, the timer is placed in the “stopped” state.
- F12-5(3) A timer is placed in running state when calling `OSTmrStart()`. The timer stays in that state unless it’s stopped, deleted, or completes its one shot.
- F12-5(4) The “Completed” state is the state a one-shot timer is in when its delay expires.

## 12-4-2 TIMER MANAGEMENT INTERNALS - OS\_TMR

A timer is a kernel object as defined by the `OS_TMR` data type (see `OS.H`) as shown in Listing 12-1.

The services provided by  $\mu\text{C}/\text{OS-III}$  to manage timers are implemented in the file `OS_TMR.C`. A  $\mu\text{C}/\text{OS-III}$  licensee has access to the source code. In this case, timer services are enabled at compile time by setting the configuration constant `OS_CFG_TMR_EN` to 1 in `OS_CFG.H`.

```
typedef struct os_tmr OS_TMR;           (1)

struct os_tmr {
    OS_OBJ_TYPE      Type;              (2)
    CPU_CHAR         *NamePtr;         (3)
    OS_TMR_CALLBACK_PTR CallbackPtr;   (4)
    void             *CallbackPtrArg;  (5)
    OS_TMR           *NextPtr;         (6)
    OS_TMR           *PrevPtr;
    OS_TICK          Match;            (7)
    OS_TICK          Remain;           (8)
    OS_TICK          Dly;              (9)
    OS_TICK          Period;           (10)
    OS_OPT           Opt;              (11)
    OS_STATE         State;            (12)
};
```

Listing 12-1 `OS_TMR` data type



- 
- L12-1(1) In  $\mu\text{C}/\text{OS-III}$ , all structures are given a data type. In fact, all data types start with “OS\_” and are all uppercase. When a timer is declared, simply use `OS_TMR` as the data type of the variable used to declare the timer.
- L12-1(2) The structure starts with a “Type” field, which allows it to be recognized by  $\mu\text{C}/\text{OS-III}$  as a timer. Other kernel objects will also have a “Type” as the first member of the structure. If a function is passed a kernel object,  $\mu\text{C}/\text{OS-III}$  is able to confirm that it is passed the proper data type. For example, if passing a message queue (`OS_Q`) to a timer service (for example `OSTmrStart()`) then  $\mu\text{C}/\text{OS-III}$  will be able to recognize that an invalid object was passed, and return an error code accordingly.
- L12-1(3) Each kernel object can be given a name for easier recognition by debuggers or  $\mu\text{C}/\text{Probe}$ . This member is simply a pointer to an ASCII string which is assumed to be NUL terminated.
- L12-1(4) The `.CallbackPtr` member is a pointer to a function that is called when the timer expires. If a timer is created and passed a `NULL` pointer, a callback would not be called when the timer expires.
- L12-1(5) If there is a non-`NULL` `.CallbackPtr` then the application code could have also specified that the callback be called with an argument when the timer expires. This is the argument that would be passed in this call.
- L12-1(6) `.NextPtr` and `.PrevPtr` are pointers used to link a timer in a doubly linked list. These are described later.
- L12-1(7) A timer expires when the timer manager variable `OSTmrTickCtr` reaches the value stored in a timer’s `.Match` field. This is also described later.
- L12-1(8) The `.Remain` contains the amount of time remaining for the timer to expire. This value is updated once per `OS_CFG_TMR_WHEEL_SIZE` (see `OS_CFG_APP.H`) that the timer task executes (described later). The value is expressed in multiples of `1/OS_CFG_TMR_TASK_RATE_HZ` of a second (see `OS_CFG_APP.H`).

- L12-1(9) The `.Dly` field contains the one-shot time when the timer is configured (i.e., created) as a one-shot timer and the initial delay when the timer is created as a periodic timer. The value is expressed in multiples of `1/OS_CFG_TMR_TASK_RATE_HZ` of a second (see `OS_CFG_APP.H`).
- L12-1(10) The `.Period` is the timer period when the timer is created to operate in periodic mode. The value is expressed in multiples of `1/OS_CFG_TMR_TASK_RATE_HZ` of a second (see `OS_CFG_APP.H`).
- L12-1(11) The `.Opt` field contains options as passed to `OSTmrCreate()`.
- L12-1(12) The `.State` field represents the current state of the timer (see Figure 12-5).

Even if the internals of the `OS_TMR` data type are understood, the application code should never access any of the fields in this data structure directly. Instead, always use the Application Programming Interfaces (APIs) provided with  $\mu$ C/OS-III.

### **12-4-3 TIMER MANAGEMENT INTERNALS - TIMER TASK**

`OS_TmrTask()` is a task created by  $\mu$ C/OS-III (assumes setting `OS_CFG_TMR_EN` to 1 in `OS_CFG.H`) and its priority is configurable by the user through  $\mu$ C/OS-III's configuration file `OS_CFG_APP.H` (see `OS_CFG_TMR_TASK_PRIO`). `OS_TmrTask()` is typically set to a medium priority.

`OS_TmrTask()` is a periodic task and uses the same interrupt source used to generate clock ticks. However, timers are generally updated at a slower rate (i.e., typically 10 Hz or so) and thus, the timer tick rate is divided down in software. If the tick rate is 1000 Hz and the desired timer rate is 10 Hz then the timer task will be signaled every 100th tick interrupt as shown in Figure 12-6.

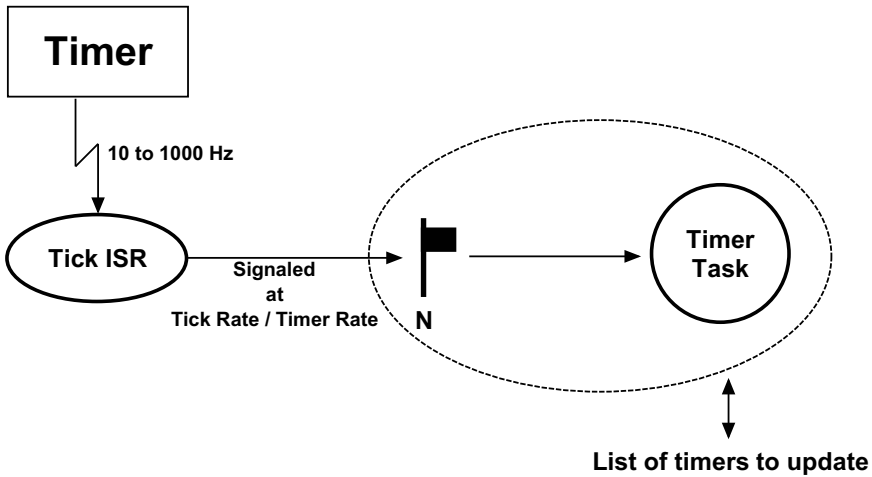

Figure 12-6 Tick ISR and Timer Task relationship

Figure 12-7 shows timing diagram associated with the timer management task.

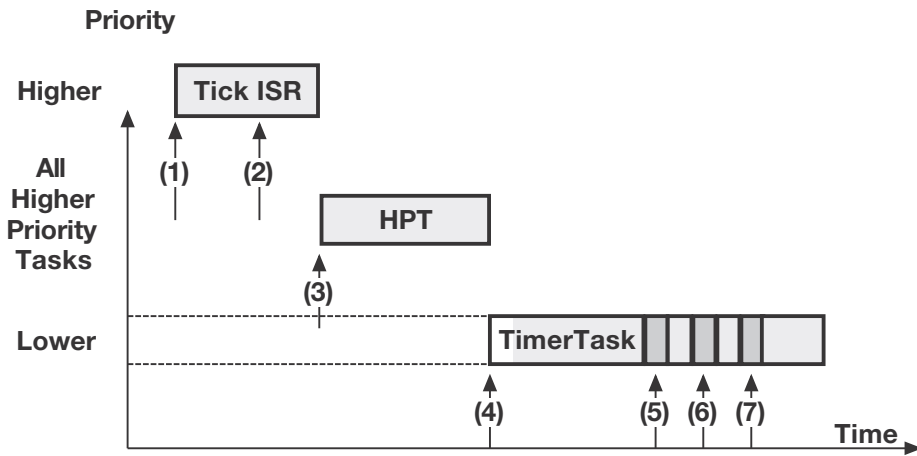

Figure 12-7 Timing Diagram

F12-7(1) The tick ISR occurs and assumes interrupts are enabled and executes.

F12-7(2) The tick ISR signals the tick task that it is time for it to update timers.

- F12-7(3) The tick ISR terminates, however there are higher priority tasks that need to execute (assuming the timer task has a lower priority). Therefore,  $\mu\text{C}/\text{OS-III}$  runs the higher priority task(s).
- F12-7(4) When all higher priority tasks have executed,  $\mu\text{C}/\text{OS-III}$  switches to the timer task and determines that there are three timers that expired.
- F12-7(5) The callback for the first timer is executed.
- F12-7(6) The callback for the second expired timer is executed.
- F12-7(7) The callback for the third expired timer is executed.

There are a few interesting things to notice:

- Execution of the callback functions is performed within the context of the timer task. This means that the application code will need to make sure there is sufficient stack space for the timer task to handle these callbacks.
- The callback functions are executed one after the other based on the order they are found in the timer list.
- The execution time of the timer task greatly depends on how many timers expire and how long each of the callback functions takes to execute. Since the callbacks are provided by the application code they have a large influence on the execution time of the timer task.
- The timer callback functions must never wait on events that would delay the timer task for excessive amounts of time, if not forever.
- Callbacks are called with the scheduler locked, so you should ensure that callbacks execute as quickly as possible.

### 12-4-4 TIMER MANAGEMENT INTERNALS - TIMER LIST

μC/OS-III might need to literally maintain hundreds of timers (if an application requires that many). The timer list management needs to be implemented such that it does not take too much CPU time to update the timers. The timer list works similarly to a tick list as shown in Figure 12-8.

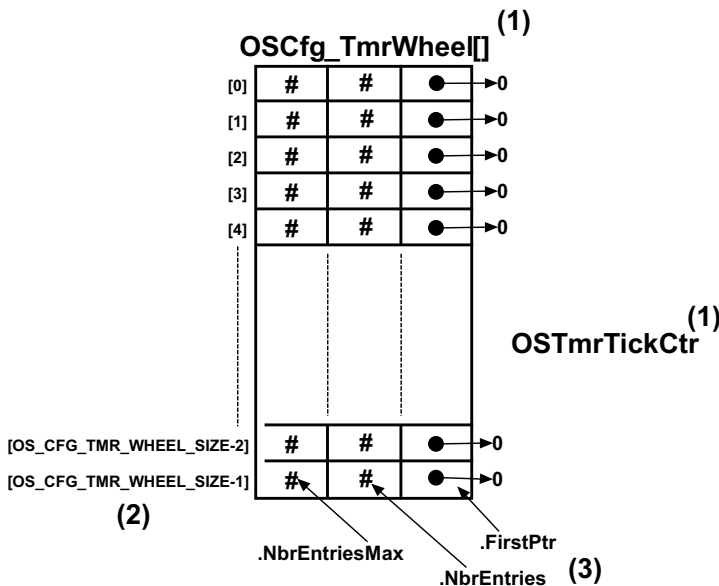

Figure 12-8 Empty Timer List

F12-8(1) The timer list consists of a table (`OSCfg_TmrWheel[]`) and a counter (`OSTmrTickCtr`).

F12-8(2) The table contains up to `OS_CFG_TMR_WHEEL_SIZE` entries, which is a compile time configuration value (see `OS_CFG_APP.H`). The number of entries depends on the amount of RAM available to the processor and the maximum number of timers in the application. A good starting point for `OS_CFG_TMR_WHEEL_SIZE` might be: `#Timers/4`. It is not recommended to make `OS_CFG_TMR_WHEEL_SIZE` an even multiple of the timer task rate. In other words, if the timer task is 10 Hz, avoid setting `OS_CFG_TMR_WHEEL_SIZE` to 10 or 100 (use 11 or 101 instead). Also, use prime numbers for the timer wheel size. Although it is not really possible to plan at compile time what will happen at run time, ideally the number of timers waiting in each entry of the table is distributed uniformly.

F12-8(3) Each entry in the table contains three fields: `.NbrEntriesMax`, `.NbrEntries` and `.FirstPtr`. `.NbrEntries` indicates how many timers are linked to this table entry. `.NbrEntriesMax` keeps track of the highest number of entries in the table. Finally, `.FirstPtr` contains a pointer to a doubly linked list of timers (through the tasks `OS_TMR`) belonging into the list at that table position.

The counter is incremented by `OS_TmrTask()` every time the tick ISR signals the task.

Timers are inserted in the timer list by calling `OSTmrStart()`. However, a timer must be created before it can be used.

An example to illustrate the process of inserting a timer in the timer list is as follows. Let's assume that the timer list is completely empty, `OS_CFG_TMR_WHEEL_SIZE` is configured to 9, and the current value of `OSTmrTickCtr` is 12 as shown in Figure 12-9. A timer is placed in the timer list when calling `OSTmrStart()`, and assumes that the timer was created with a delay of 1 and that this timer will be a one-shot timer as follows:

```
OS_TMR MyTmr1;
OS_TMR MyTmr2;

void MyTask (void *p_arg)
{
    OS_ERR err;

    while (DEF_ON) {
        :
        OSTmrCreate((OS_TMR *) &MyTmr1,
                    (OS_CHAR *) "My Timer #1",
                    (OS_TICK) 1,
                    (OS_TICK) 0,
                    (OS_OPT) OS_OPT_TMR_ONE_SHOT,
                    (OS_TMR_CALLBACK_PTR) 0;
                    (OS_ERR *) &err;
        /* Check 'err' */
        OSTmrStart ((OS_TMR *) &MyTmr1,
                    (OS_ERR *) &err);
        /* Check "err" */
        // Continues in the next code listing!
```

Listing 12-2 Creating and Starting a timer

Since `OSTmrTickCtr` has a value of 12, the timer will expire when `OSTmrTickCtr` reaches 13, or during the next time the timer task is signaled. Timers are inserted in the `OSCfg_TmrWheel[]` table using the following equation:

$$\begin{aligned} \text{MatchValue} &= \text{OSTmrTickCtr} + \text{dly} \\ \text{Index into OSCfg\_TmrWheel}[\ ] &= \text{MatchValue} \% \text{OS\_CFG\_TMR\_WHEEL\_SIZE} \end{aligned}$$

Where “dly” (in this example) is the value passed in the third argument of `OSTmrCreate()` (i.e., 1 in this example). Again, using the example, we arrive at the following:

$$\begin{aligned} \text{MatchValue} &= 12 + 1 \\ \text{Index into OSCfg\_TickWheel}[\ ] &= 13 \% 9 \end{aligned}$$

or,

$$\begin{aligned} \text{MatchValue} &= 13 \\ \text{Index into OSCfg\_TickWheel}[\ ] &= 4 \end{aligned}$$

Because of the “circular” nature of the table (a modulo operation using the size of the table), the table is referred to as a timer wheel, and each entry is a spoke in the wheel.

The timer is entered at index 4 in the timer wheel, `OSCfg_TmrWheel[]`. In this case, the `OS_TMR` is placed at the head of the list (i.e., pointed to by `OSCfg_TmrWheel[4].FirstPtr`), and the number of entries at index 4 is incremented (i.e., `OSCfg_TmrWheel[4].NbrEntries` will be 1). “MatchValue” is placed in the `OS_TMR` field `.Match`. Since this is the first timer inserted in the timer list at index 4, the `.NextPtr` and `.PrevPtr` both point to `NULL`.

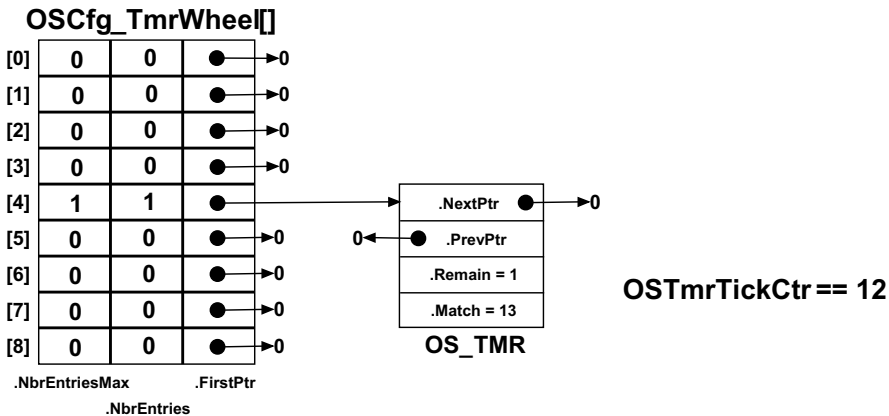

Figure 12-9 Inserting a timer in the timer list

The code below shows creating and starting another timer. This is performed “before” the timer task is signaled.

```
// Continuation of code from previous code listing.
:
:
OSTmrCreate((OS_TMR          *)&MyTmr2,
            (OS_CHAR          *)"My Timer #2",
            (OS_TICK          )10,
            (OS_TICK          )0,
            (OS_OPT           )OS_OPT_TMR_ONE_SHOT,
            (OS_TMR_CALLBACK_PTR)0;
            (OS_ERR           *)&err;
/* Check 'err' */
OSTmrStart ((OS_TMR *)&MyTmr,
            (OS_ERR *)&err);
/* Check 'err' */
}
}
```

Listing 12-3 **Creating and Starting a timer - continued**

μC/OS-III will calculate the match value and index as follows:

```
MatchValue          = 12 + 10
Index into OSCfg_TmrWheel[] = 22 % 9
```

or,

```
MatchValue          = 22
Index into OSCfg_TickWheel[] = 4
```

The “second timer” will be inserted at the same table entry as shown in Figure 12-10, but sorted so that the timer with the least amount of time remaining before expiration is placed at the head of the list, and the timer with the longest to wait at the end.



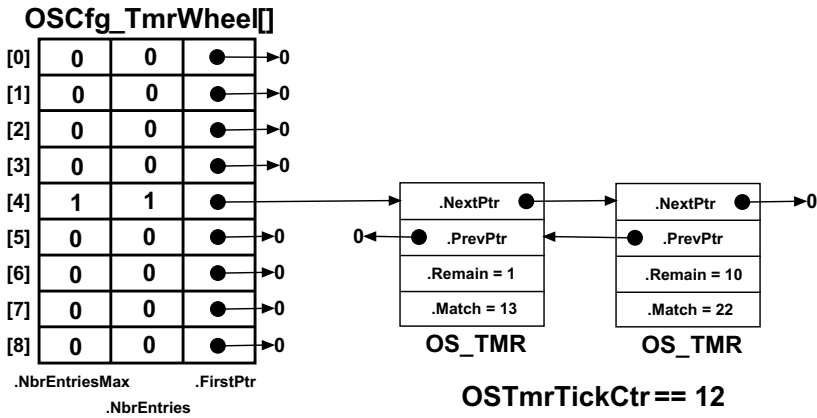

Figure 12-10 Inserting a second timer in the tick list

When the timer task executes (see `OS_TmrTask()` in `OS_TMR.C`), it starts by incrementing `OSTmrTickCtr` and determines which table entry (i.e., spoke) it needs to update. Then, if there are timers in the list at this entry (i.e., `.FirstPtr` is not `NULL`), each `OS_TMR` is examined to determine whether the `.Match` value “matches” `OSTmrTickCtr` and, if so, the `OS_TMR` is removed from the list and `OS_TmrTask()` calls the timer callback function, assuming one was defined when the timer was created. The search through the list terminates as soon as `OSTmrTickCtr` does not match the timer’s `.Match` value. There is no point in looking any further in the list since the list is already sorted.

Note that `OS_TmrTask()` does most of its work with the scheduler locked. However, because the list is sorted, and the search through the list terminates as soon as there no longer is a match, the critical section should be fairly short.

## **12-5 SUMMARY**

Timers are down counters that perform an action when the counter reaches zero. The action is provided by the user through a callback function.

$\mu$ C/OS-III allows application code to create any number of timers (limited only by the amount of RAM available).

The callback functions are executed in the context of the timer task with the scheduler locked. Keep callback functions as short and as fast as possible and do not have the callbacks make blocking calls.

## Resource Management

This chapter will discuss services provided by  $\mu\text{C}/\text{OS-III}$  to manage shared resources. A shared resource is typically a variable (static or global), a data structure, table (in RAM), or registers in an I/O device.

When protecting a shared resource it is preferred to use mutual exclusion semaphores, as will be described in this chapter. Other methods are also presented.

Tasks can easily share data when all tasks exist in a single address space and can reference global variables, pointers, buffers, linked lists, ring buffers, etc. Although sharing data simplifies the exchange of information between tasks, it is important to ensure that each task has exclusive access to the data to avoid contention and data corruption.

For example, when implementing a module that performs a simple time-of-day algorithm in software, the module obviously keeps track of hours, minutes and seconds. The **TimeOfDay()** task may appear as that shown in Listing 13-1.

Imagine if this task was preempted by another task because an interrupt occurred, and, the other task was more important than the **TimeOfDay()** task) after setting the Minutes to 0. Now imagine what will happen if this higher priority task wants to know the current time from the time-of-day module. Since the Hours were not incremented prior to the interrupt, the higher-priority task will read the time incorrectly and, in this case, it will be incorrect by a whole hour.

The code that updates variables for the **TimeOfDay()** task must treat all of the variables indivisibly (or atomically) whenever there is possible preemption. Time-of-day variables are considered shared resources and any code that accesses those variables must have exclusive access through what is called a critical section.  $\mu\text{C}/\text{OS-III}$  provides services to protect shared resources and enables the easy creation of critical sections.

```
CPU_INT08U  Hours;
CPU_INT08U  Minutes;
CPU_INT08U  Seconds;

void TimeOfDay (void *p_arg)
{
    OS_ERR  err;

    (void)&p_arg;
    while (DEF_ON) {
        OSTimeDlyHMSM(0,
                      0,
                      1,
                      0,
                      OS_OPT_TIME_HMSM_STRICT,
                      &err);
        /* Examine "err" to make sure the call was successful */
        Seconds++;
        if (Seconds > 59) {
            Seconds = 0;
            Minutes++;
            if (Minutes > 59) {
                Minutes = 0;
                Hours++;
                if (Hours > 23) {
                    Hours = 0;
                }
            }
        }
    }
}
```

Listing 13-1 Faulty Time-Of-Day clock task

The most common methods of obtaining exclusive access to shared resources and to create *critical sections* are:

- disabling interrupts
- disabling the scheduler
- using semaphores
- using mutual exclusion semaphores (a.k.a. a mutex)

The mutual exclusion mechanism used depends on how fast the code will access a shared resource, as shown in Table 13-1.

| Resource Sharing Method         | When should you use?   |
|---------------------------------|--|
| Disable/Enable Interrupts       | <p>When access to shared resource is very quick (reading from or writing to few variables) and access is faster than <math>\mu\text{C}/\text{OS-III}</math>'s interrupt disable time.</p> <p>It is highly recommended to not use this method as it impacts interrupt latency.</p>  |
| Locking/Unlocking the Scheduler | <p>When access time to the shared resource is longer than <math>\mu\text{C}/\text{OS-III}</math>'s interrupt disable time, but shorter than <math>\mu\text{C}/\text{OS-III}</math>'s scheduler lock time.</p> <p>Locking the scheduler has the same effect as making the task that locks the scheduler the highest-priority task.</p> <p>It is recommended not to use this method since it defeats the purpose of using <math>\mu\text{C}/\text{OS-III}</math>. However, it is a better method than disabling interrupts, as it does not impact interrupt latency.</p> |
| Semaphores                      | <p>When all tasks that need to access a shared resource do not have deadlines. This is because semaphores may cause unbounded priority inversions (described later). However, semaphore services are slightly faster (in execution time) than mutual-exclusion semaphores.</p>   |
| Mutual Exclusion Semaphores     | <p>This is the preferred method for accessing shared resources, especially if the tasks that need to access a shared resource have deadlines.</p> <p>Remember that <math>\mu\text{C}/\text{OS-III}</math>'s mutual exclusion semaphores have a built-in priority inheritance mechanism, which avoids unbounded priority inversions.</p> <p>However, mutual exclusion semaphore services are slightly slower (in execution time) than semaphores since the priority of the owner may need to be changed, which requires CPU processing.</p>                             |

Table 13-1 **Resource sharing**

## 13-1 DISABLE/ENABLE INTERRUPTS

The easiest and fastest way to gain exclusive access to a shared resource is by disabling and enabling interrupts, as shown in the pseudo-code in Listing 13-2.

```
Disable Interrupts;  
Access the resource;  
Enable Interrupts;
```

Listing 13-2 **Disabling and Enabling Interrupts**

μC/OS-III uses this technique (as do most, if not all, kernels) to access certain internal variables and data structures, ensuring that these variables and data structures are manipulated atomically. However, disabling and enabling interrupts are actually CPU-related functions rather than OS-related functions and functions in CPU-specific files are provided to accomplish this (see the CPU.H file of the processor being used). The services provided in the CPU module are called μC/CPU. Each different target CPU architecture has its own set of μC/CPU-related files.

```
void OS_Function (void)  
{  
    CPU_SR_ALLOC();           (1)  
  
    CPU_CRITICAL_ENTER();    (2)  
    Access the resource;     (3)  
    CPU_CRITICAL_EXIT();     (4)  
}
```

Listing 13-3 **Using CPU macros to disable and enable interrupts**

L13-3(1) The `CPU_SR_ALLOC()` macro is required when the other two macros that disable/enable interrupts are used. This macro simply allocates storage for a local variable to hold the value of the current interrupt disable status of the CPU. If interrupts are already disabled we do not want to enable them upon exiting the critical section.

- L13-3(2) `CPU_CRITICAL_ENTER()` saves the current state of the CPU interrupt disable flag(s) in the local variable allocated by `CPU_SR_ALLOC()` and disables all maskable interrupts.
- L13-3(3) The critical section of code is then accessed without fear of being changed by either an ISR or another task because interrupts are disabled. In other words, this operation is now atomic.
- L13-3(4) `CPU_CRITICAL_EXIT()` restores the previously saved interrupt disable status of the CPU from the local variable.

`CPU_CRITICAL_ENTER()` and `CPU_CRITICAL_EXIT()` are always used in pairs. Interrupts should be disabled for as short a time as possible as disabling interrupts impacts the response of the system to interrupts. This is known as interrupt latency. Disabling and enabling is used only when changing or copying a few variables.

Note, this is the only way that a task can share variables or data structures with an ISR.  $\mu$ C/CPU provides a way to actually measure interrupt latency.

When using  $\mu$ C/OS-III, interrupts may be disabled for as much time as  $\mu$ C/OS-III does, without affecting *interrupt latency*. Obviously, it is important to know how long  $\mu$ C/OS-III disables interrupts, which depends on the CPU used.

Although this method works, avoid disabling interrupts as it affects the responsiveness of the system to real-time events.

## 13-2 LOCK/UNLOCK

If the task does not share variables or data structures with an ISR, disable and enable  $\mu$ C/OS-III's scheduler while accessing the resource, as shown in Listing 13-4.

```
void OS_Function (void)
{
    CPU_SR_ALLOC();           (1)
    CPU_CRITICAL_ENTER();    (2)
    Access the resource;     (3)
    CPU_CRITICAL_EXIT();     (4)
}
```

Listing 13-4 **Accessing a resource with the scheduler locked**

Using this method, two or more tasks share data without the possibility of contention. Note that while the scheduler is locked, interrupts are enabled and if an interrupt occurs while in the critical section, the ISR is executed immediately. At the end of the ISR, the kernel always returns to the interrupted task even if a higher priority task is made ready to run by the ISR. Since the ISR returns to the interrupted task, the behavior of the kernel is similar to that of a non-preemptive kernel (while the scheduler is locked).

`OSSchedLock()` and `OSSchedUnlock()` can be nested up to 250 levels deep. The scheduler is invoked only when `OSSchedUnlock()` is called the same number of times the application called `OSSchedLock()`.

After the scheduler is unlocked,  $\mu$ C/OS-III performs a context switch if a higher priority task is ready to run.

$\mu$ C/OS-III will not allow the user to make blocking calls when the scheduler is locked. If the application were able to make blocking calls, the application would most likely fail.

Although this method works well, avoid disabling the scheduler as it defeats the purpose of having a preemptive kernel. Locking the scheduler makes the current task the highest priority task.



### 13-3 SEMAPHORES

A semaphore originally was a mechanical signaling mechanism. The railroad industry used the device to provide a form of mutual exclusion for railroad tracks shared by more than one train. In this form, the semaphore signaled trains by closing a set of mechanical arms to block a train from a section of track that was currently in use. When the track became available, the arm would swing up and the waiting train would then proceed.

The notion of using a semaphore in software as a means of synchronization was invented by the Dutch computer scientist Edgser Dijkstra in 1959. In computer software, a semaphore is a protocol mechanism offered by most multitasking kernels. Semaphores, originally used to control access to shared resources, now are used for synchronization as described in Chapter 14, “Synchronization” on page 251. However, it is useful to describe how semaphores can be used to share resources. The pitfalls of semaphores will be discussed in a later section.

A semaphore was originally a “lock mechanism” and code acquired the key to this lock to continue execution. Acquiring the key means that the executing task has permission to enter the section of otherwise locked code. Entering a section of locked code causes the task to wait until the key becomes available.

Typically, two types of semaphores exist: binary semaphores and counting semaphores. As its name implies, a binary semaphore can only take two values: 0 or 1. A counting semaphore allows for values between 0 and 255, 65,535, or 4,294,967,295, depending on whether the semaphore mechanism is implemented using 8, 16, or 32 bits, respectively. For  $\mu$ C/OS-III, the maximum value of a semaphore is determined by the data type `OS_SEM_CTR` (see `OS_TYPE.H`), which can be changed as needed (assuming  $\mu$ C/OS-III's source code is available). Along with the semaphore's value,  $\mu$ C/OS-III also keeps track of tasks waiting for the semaphore's availability.

Only tasks are allowed to use semaphores when semaphores are used for sharing resources; ISRs are not allowed.

A semaphore is a kernel object defined by the `OS_SEM` data type, which is defined by the structure `os_sem` (see `OS.H`). The application can have any number of semaphores (limited only by the amount of RAM available).

There are a number of operations the application is able to perform on semaphores, summarized in Table 13-2. In this chapter, only three functions used most often are discussed: `OSSemCreate()`, `OSSemPend()`, and `OSSemPost()`. Other functions are described in Appendix A, “*µC/OS-III API Reference Manual*” on page 375. When semaphores are used for sharing resources, every semaphore function must be called from a task and never from an ISR. The same limitation does not apply when using semaphores for signaling, as described later in Chapter 13.

| <b>Function Name</b>          | <b>Operation</b>                              |
|-------------------------------|---|
| <code>OSSemCreate()</code>    | Create a semaphore.                           |
| <code>OSSemDel()</code>       | Delete a semaphore.                           |
| <code>OSSemPend()</code>      | Wait on a semaphore.                          |
| <code>OSSemPendAbort()</code> | Abort the wait on a semaphore.                |
| <code>OSSemPost()</code>      | Release or signal a semaphore.                |
| <code>OSSemSet()</code>       | Force the semaphore count to a desired value. |

Table 13-2 **Semaphore API summary**

### 13-3-1 BINARY SEMAPHORES

A task that wants to acquire a resource must perform a Wait (or Pend) operation. If the semaphore is available (the semaphore value is greater than 0), the semaphore value is decremented, and the task continues execution (owning the resource). If the semaphore's value is 0, the task performing a Wait on the semaphore is placed in a waiting list.  $\mu\text{C}/\text{OS-III}$  allows a timeout to be specified. If the semaphore is not available within a certain amount of time, the requesting task is made ready to run, and an error code (indicating that a timeout has occurred) is returned to the caller.

A task releases a semaphore by performing a Signal (or Post) operation. If no task is waiting for the semaphore, the semaphore value is simply incremented. If there is at least one task waiting for the semaphore, the highest-priority task waiting on the semaphore is made ready to run, and the semaphore value is not incremented. If the readied task has a higher priority than the current task (the task releasing the semaphore), a context switch occurs and the higher-priority task resumes execution. The current task is suspended until it again becomes the highest-priority task that is ready to run.

The operations described above are summarized using the pseudo-code shown in Listing 13-5.

```
OS_SEM MySem;                                (1)

void main (void)
{
    OS_ERR err;
    :
    :
    OSInit(&err);
    :
    OSSemCreate(&MySem,                        (2)
                "My Semaphore",              (3)
                1,                            (4)
                &err);                       (5)
    /* Check "err" */
    :
    /* Create task(s) */
    :
    OSStart(&err);
    (void)err;
}
```

Listing 13-5 Using a semaphore to access a shared resource

- L13-5(1) The application must declare a semaphore as a variable of type `OS_SEM`. This variable will be referenced by other semaphore services.
- L13-5(2) Create a semaphore by calling `OSSemCreate()` and pass the address to the semaphore allocated in (1). The semaphore must be created before it can be used by other tasks. Here, the semaphore is initialized in startup code (i.e., `main ()`), however it could also be initialized by a task (but it must be initialized before it is used).
- L13-5(3) Assign an ASCII name to the semaphore, which can be used by debuggers or  $\mu$ C/Probe to easily identify the semaphore. Storage for the ASCII characters is typically in ROM, which is typically more plentiful than RAM. If it is necessary to change the name of the semaphore at runtime, store the characters in an array in RAM and simply pass the address of the array to `OSSemCreate()`. Of course, the array must be NUL terminated.
- L13-5(4) Specify the initial value of the semaphore. Initialize the semaphore to 1 when the semaphore is used to access a single shared resource (as in this example).
- L13-5(5) `OSSemCreate()` returns an error code based on the outcome of the call. If all the arguments are valid, `err` will contain `OS_ERR_NONE`. Refer to the description of `OSSemCreate()` in Appendix A, “ $\mu$ C/OS-III API Reference Manual” on page 375 for a list of other error codes and their meaning.

```
void Task1 (void *p_arg)
{
    OS_ERR err;
    CPU_TS ts;

    while (DEF_ON) {
        :
        OS_SemPend(&MySem,                (6)
                  0,                      (7)
                  OS_OPT_PEND_BLOCKING,   (8)
                  &ts,                   (9)
                  &err);                 (10)
        switch (err) {
            case OS_ERR_NONE:
                Access Shared Resource;   (11)
                OS_SemPost(&MySem,       (12)
                          OS_OPT_POST_1, (13)
                          &err);        (14)
                /* Check "err" */
                break;

            case OS_ERR_PEND_ABORT:
                /* The pend was aborted by another task */
                break;

            case OS_ERR_OBJ_DEL:
                /* The semaphore was deleted */
                break;

            default:
                /* Other errors */
                break;
        }
    }
}
```

Listing 13-6 Using a semaphore to access a shared resource

- L13-6(6) The task pends (or waits) on the semaphore by calling `OS_SemPend()`. The application must specify the desired semaphore to wait upon, and the semaphore must have been previously created.
- L13-6(7) The next argument is a timeout specified in number of clock ticks. The actual timeout depends on the tick rate. If the tick rate (see `OS_CFG_APP.H`) is set to 1000, a timeout of 10 ticks represents 10 milliseconds. Specifying a timeout of zero (0) means waiting forever for the semaphore.

- L13-6(8) The third argument specifies how to wait. There are two options: `OS_OPT_PEND_BLOCKING` and `OS_OPT_PEND_NON_BLOCKING`. The blocking option means that if the semaphore is not available, the task calling `OSSemPend()` will wait until the semaphore is posted or until the timeout expires. The non-blocking option indicates that if the semaphore is not available, `OSSemPend()` will return immediately and not wait. This last option is rarely used when using a semaphore to protect a shared resource.
- L13-6(9) When the semaphore is posted,  $\mu$ C/OS-III reads a “timestamp” and returns this timestamp when `OSSemPend()` returns. This feature allows the application to know “when” the post happened and the semaphore was released. At this point, `OS_TS_GET()` is read to get the current timestamp and compute the difference, indicating the length of the wait.
- L13-6(10) `OSSemPend()` returns an error code based on the outcome of the call. If the call is successful, `err` will contain `OS_ERR_NONE`. If not, the error code will indicate the reason for the error. See Appendix A, “ $\mu$ C/OS-III API Reference Manual” on page 375 for a list of possible error code for `OSSemPend()`. Checking for error return values is important since other tasks might delete or otherwise abort the pend. However, it is not a recommended practice to delete kernel objects at run time as the action may cause serious problems.
- L13-6(11) The resource can be accessed when `OSSemPend()` returns, if there are no errors.
- L13-6(12) When finished accessing the resource, simply call `OSSemPost()` and specify the semaphore to be released.
- L13-6(13) `OS_OPT_POST_1` indicates that the semaphore is signaling a single task, if there are many tasks waiting on the semaphore. In fact, always specify this option when a semaphore is used to access a shared resource.
- L13-6(14) As with most  $\mu$ C/OS-III functions, specify the address of a variable that will receive an error message from the call.

```
void Task2 (void *p_arg)
{
    OS_ERR err;
    CPU_TS ts;

    while (DEF_ON) {
        :
        OSSemPend(&MySem,                                (15)
                 0,
                 OS_OPT_PEND_BLOCKING,
                 &ts,
                 &err);
        switch (err) {
            case OS_ERR_NONE:
                Access Shared Resource;
                OSSemPost(&MySem,
                         OS_OPT_POST_1,
                         &err);
                /* Check "err" */
                break;

            case OS_ERR_PEND_ABORT:
                /* The pend was aborted by another task */
                break;

            case OS_ERR_OBJ_DEL:
                /* The semaphore was deleted */
                break;

            default:
                /* Other errors */
        }
    }
}
```

Listing 13-7 Using a semaphore to access a shared resource

L13-7(15) Another task wanting to access the shared resource needs to use the same procedure to access the shared resource.

Semaphores are especially useful when tasks share I/O devices. Imagine what would happen if two tasks were allowed to send characters to a printer at the same time. The printer would contain interleaved data from each task. For instance, the printout from Task 1 printing “I am Task 1,” and Task 2 printing “I am Task 2,” could result in “I Ia amm T Tasask k1 2”. In this case, use a semaphore and initialize it to 1 (i.e., a binary semaphore). The rule is simple: to access the printer each task must first obtain the resource’s semaphore. Figure 13-1 shows tasks competing for a semaphore to gain exclusive access to the printer. Note that a key, indicating that each task must obtain this key to use the printer, represents the semaphore symbolically.

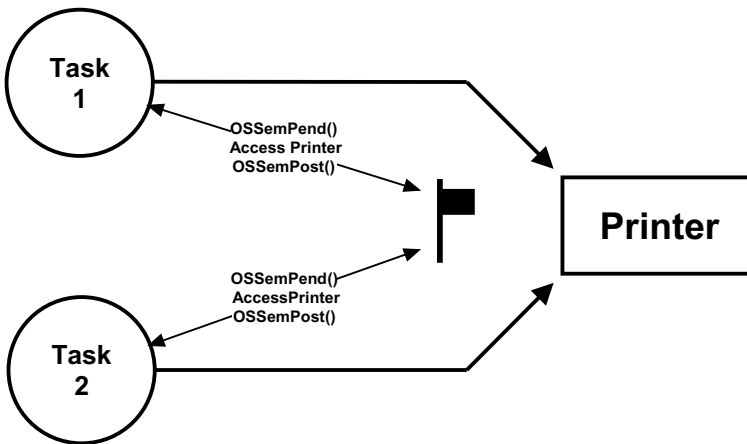

Figure 13-1 Using a semaphore to access a printer

The above example implies that each task knows about the existence of the semaphore to access the resource. It is almost always better to encapsulate the critical section and its protection mechanism. Each task would therefore not know that it is acquiring a semaphore when accessing the resource. For example, an RS-232C port is used by multiple tasks to send commands and receive responses from a device connected at the other end as shown in Figure 13-2.



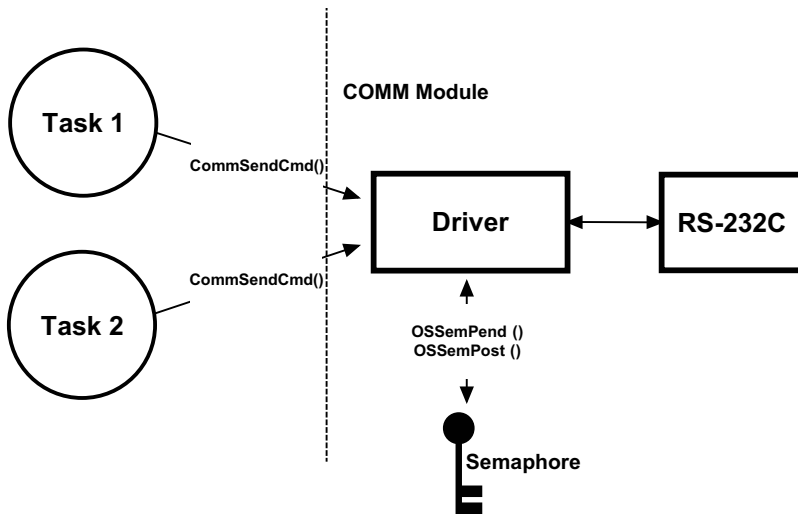

Figure 13-2 Hiding a semaphore from a task

The function `CommSendCmd()` is called with three arguments: the ASCII string containing the command, a pointer to the response string from the device, and finally, a timeout in case the device does not respond within a certain amount of time. The pseudo-code for this function is shown in Listing 13-8.

```

APP_ERR CommSendCmd (CPU_CHAR *cmd,
                    CPU_CHAR *response,
                    OS_TICK  timeout)
{
    Acquire serial port's semaphore;
    Send "cmd" to device;
    Wait for response with "timeout";
    if (timed out) {
        Release serial port's semaphore;
        return (error code);
    } else {
        Release serial port's semaphore;
        return (no error);
    }
}

```

Listing 13-8 Encapsulating the use of a semaphore

Each task that needs to send a command to the device must call this function. The semaphore is assumed to be initialized to 1 (i.e., available) by the communication driver initialization routine. The first task that calls `CommSendCmd()` acquires the semaphore, proceeds to send the command, and waits for a response. If another task attempts to send a command while the port is busy, this second task is suspended until the semaphore is released. The second task appears simply to have made a call to a normal function that will not return until the function performs its duty. When the semaphore is released by the first task, the second task acquires the semaphore and is allowed to use the RS-232C port.

### **13-3-2 COUNTING SEMAPHORES**

A counting semaphore is used when elements of a resource can be used by more than one task at the same time. For example, a counting semaphore is used in the management of a buffer pool, as shown in Figure 13-3. Assume that the buffer pool initially contains 10 buffers. A task obtains a buffer from the buffer manager by calling `BufReq()`. When the buffer is no longer needed, the task returns the buffer to the buffer manager by calling `BufRel()`. The pseudo-code for these functions is shown in Listing 13-9.

The buffer manager satisfies the first 10 buffer requests because the semaphore is initialized to 10. When all buffers are used, a task requesting a buffer is suspended until a buffer becomes available. Use  $\mu$ C/OS-III's `OSMemGet()` and `OSMemPut()` (see Chapter 17, "Memory Management" on page 323) to obtain a buffer from the buffer pool. When a task is finished with the buffer it acquired, the task calls `BufRel()` to return the buffer to the buffer manager and the buffer is inserted into the linked list before the semaphore is signaled. By encapsulating the interface to the buffer manager in `BufReq()` and `BufRel()`, the caller does not need to be concerned with actual implementation details.

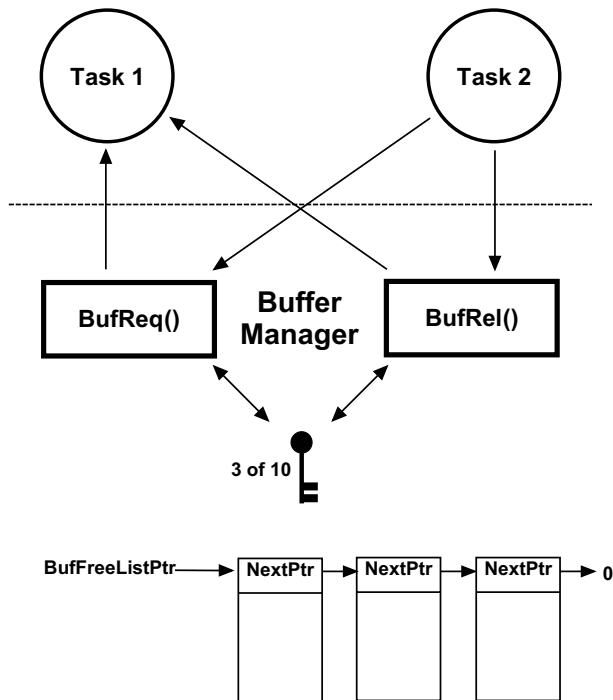

Figure 13-3 Using a counting semaphore

```

BUF *BufReq (void)
{
    BUF *ptr;

    Wait on semaphore;
    ptr = OSMemGet(...);          /* Get a buffer */
    return (ptr);
}

void BufRel (BUF *ptr)
{
    OSMemPut(..., (void *)ptr, ...); /* Return the buffer */
    Signal semaphore;
}

```

Listing 13-9 Buffer management using a semaphore.

Note that the details of creating the memory partition are removed since this is discussed in Chapter 17, “Memory Management” on page 323. The semaphore is used here to extend the memory management capabilities of  $\mu\text{C}/\text{OS-III}$ , and to provide it with a blocking mechanism. However, only tasks can make `BufReq()` and `BufRel()` calls.

### **13-3-3 NOTES ON SEMAPHORES**

Using a semaphore to access a shared resource does not increase interrupt latency. If an ISR or the current task makes a higher priority task ready to run while accessing shared data, the higher priority task executes immediately.

An application may have as many semaphores as required to protect a variety of different resources. For example, one semaphore may be used to access a shared display, another to access a shared printer, another for shared data structures, and another to protect a pool of buffers, etc. However, it is preferable to use semaphores to protect access to I/O devices rather than memory locations.

Semaphores are often overused. The use of a semaphore to access a simple shared variable is overkill in most situations. The overhead involved in acquiring and releasing the semaphore consumes valuable CPU time. Perform the job more efficiently by disabling and enabling interrupts, however there is an indirect cost to disabling interrupts: even higher priority tasks that do not share the specific resource are blocked from using the CPU. Suppose, for instance, that two tasks share a 32-bit integer variable. The first task increments the variable, while the second task clears it. When considering how long a processor takes to perform either operation, it is easy to see that a semaphore is not required to gain exclusive access to the variable. Each task simply needs to disable interrupts before performing its operation on the variable and enable interrupts when the operation is complete. A semaphore should be used if the variable is a floating-point variable and the microprocessor does not support hardware floating-point operations. In this case, the time involved in processing the floating-point variable may affect interrupt latency if interrupts are disabled.

Semaphores are subject to a serious problem in real-time systems called priority inversion, which is described in section 13-3-5 “Priority Inversions” on page 232.

### 13-3-4 SEMAPHORE INTERNALS (FOR RESOURCE SHARING)

As previously mentioned, a semaphore is a kernel object as defined by the `OS_SEM` data type, which is derived from the structure `os_sem` (see `OS.H`) as shown in Listing 13-10.

The services provided by  $\mu$ C/OS-III to manage semaphores are implemented in the file `OS_SEM.C`.  $\mu$ C/OS-III licensees have access to the source code. In this case, semaphore services are enabled at compile time by setting the configuration constant `OS_CFG_SEM_EN` to 1 in `OS_CFG.H`.

```
typedef struct os_sem OS_SEM;           (1)

struct os_sem {
    OS_OBJ_TYPE      Type;              (2)
    CPU_CHAR         *NamePtr;         (3)
    OS_PEND_LIST     PendList;         (4)
    OS_SEM_CTR       Ctr;              (5)
    CPU_TS           TS;               (6)
};
```

Listing 13-10 **OS\_SEM** data type

- L13-10(1) In  $\mu$ C/OS-III, all structures are given a data type. All data types start with “OS\_” and are uppercase. When a semaphore is declared, simply use `OS_SEM` as the data type of the variable used to declare the semaphore.
- L13-10(2) The structure starts with a “Type” field, which allows it to be recognized by  $\mu$ C/OS-III as a semaphore. Other kernel objects will also have a “.Type” as the first member of the structure. If a function is passed a kernel object,  $\mu$ C/OS-III will confirm that it is being passed the proper data type. For example, if passing a message queue (`OS_Q`) to a semaphore service (for example `OS_SemPend()`),  $\mu$ C/OS-III will recognize that an invalid object was passed, and return an error code accordingly.
- L13-10(3) Each kernel object can be given a name for easier recognition by debuggers or  $\mu$ C/Probe. This member is simply a pointer to an ASCII string, which is assumed to be NUL terminated.

L13-10(4) Since it is possible for multiple tasks to wait (or pend) on a semaphore, the semaphore object contains a pend list as described in Chapter 10, “Pend Lists (or Wait Lists)” on page 177.

L13-10(5) A semaphore contains a counter. As explained above, the counter can be implemented as either an 8-, 16- or 32-bit value, depending on how the data type `OS_SEM_CTR` is declared in `OS_TYPE.H`.

`μC/OS-III` does not make a distinction between binary and counting semaphores. The distinction is made when the semaphore is created. If creating a semaphore with an initial value of 1, it is a binary semaphore. When creating a semaphore with a value  $> 1$ , it is a counting semaphore. In the next chapter, we discover that a semaphore is more often used as a signaling mechanism and therefore, the semaphore counter is initialized to zero.

L13-10(6) A semaphore contains a timestamp used to indicate the last time the semaphore was posted. `μC/OS-III` assumes the presence of a free-running counter that allows the application to make time measurements. When the semaphore is posted, the free-running counter is read and the value is placed in this field, which is returned when `OSSemPend()` is called. The value of this field is more useful when a semaphore is used as a signaling mechanism (see Chapter 14, “Synchronization” on page 251), as opposed to a resource-sharing mechanism.

Even if the user understands the internals of the `OS_SEM` data type, the application code should never access any of the fields in this data structure directly. Instead, always use the APIs provided with `μC/OS-III`.

As previously mentioned, semaphores must be created before they can be used by an application.

A task waits on a semaphore before accessing a shared resource by calling `OSSemPend()` as shown in Listing 13-11 (see Appendix A, “`μC/OS-III` API Reference Manual” on page 375 for details regarding the arguments).

```

OS_SEM MySem;

void MyTask (void *p_arg)
{
    OS_ERR err;
    CPU_TS ts;

    :
    while (DEF_ON) {
        :
        OSSemPend(&MySem,          /* (1) Pointer to semaphore          */
                 10,              /* Wait up until this time for the semaphore */
                 OS_OPT_PEND_BLOCKING, /* Option(s)                          */
                 &ts,             /* Returned timestamp of when sem. was released */
                 &err);          /* Pointer to Error returned          */
        :
        /* Check "err" */          /* (2)                                */
        :
        OSSemPost(&MySem,         /* (3) Pointer to semaphore          */
                 OS_OPT_POST_1,  /* Option(s) ... always OS_OPT_POST_1  */
                 &err);         /* Pointer to Error returned          */
        /* Check "err" */
        :
        :
    }
}

```

Listing 13-11 Pending on and Posting to a Semaphore

- L13-11(1) When called, `OSSemPend()` starts by checking the arguments passed to this function to make sure they have valid values.

If the semaphore counter (`.Ctr` of `OS_SEM`) is greater than zero, the counter is decremented and `OSSemPend()` returns. If `OSSemPend()` returns without error, then the task now owns the shared resource.

When the semaphore counter is zero, this indicates that another task owns the semaphore, and the calling task may need to wait for the semaphore to be released. If specifying `OS_OPT_PEND_NON_BLOCKING` as the option (the application does not want the task to block), `OSSemPend()` returns immediately to the caller and the returned error code indicates that the semaphore is unavailable. Use this option if the task does not want to wait for the resource to be available, and would prefer to do something else and check back later.

If specifying the `OS_OPT_PEND_BLOCKING` option, the calling task will be inserted in the list of tasks waiting for the semaphore to become available. The task is inserted in the list by priority order and therefore, the highest priority task waiting on the semaphore is at the beginning of the list.

If specifying a non-zero timeout, the task will also be inserted in the tick list. A zero value for a timeout indicates that the user is willing to wait forever for the semaphore to be released. Most of the time, specify an infinite timeout when using the semaphore in resource sharing. Adding a timeout may temporarily break a deadlock, however, there are better ways of preventing deadlock at the application level (e.g., never hold more than one semaphore at the same time; resource ordering; etc.).

The scheduler is called since the current task is no longer able to run (it is waiting for the semaphore to be released). The scheduler will then run the next highest-priority task that is ready to run.

When the semaphore is released and the task that called `OSSemPend()` is again the highest-priority task,  $\mu\text{C}/\text{OS-III}$  examines the task status to determine the reason why `OSSemPend()` is returning to its caller. The possibilities are:

- 1) The semaphore was given to the waiting task
- 2) The pend was aborted by another task
- 3) The semaphore was not posted within the specified timeout
- 4) The semaphore was deleted

When `OSSemPend()` returns, the caller is notified of the above outcome through an appropriate error code.



L13-11(2) If `OSSemPend()` returns with `err` set to `OS_ERR_NONE`, assume that you now have access to the resource.

If `err` contains anything else, `OSSemPend()` either timed out (if the timeout argument was non-zero), the pend was aborted by another task, or the semaphore was deleted by another task. It is always important to examine the returned error code and not assume that everything went well.

L13-11(3) When the task is finished accessing the resource, it needs to call `OSSemPost()` and specify the same semaphore. Again, `OSSemPost()` starts by checking the arguments passed to this function to make sure there are valid values.

`OSSemPost()` then calls `OS_TS_GET()` to obtain the current timestamp so it can place that information in the semaphore to be used by `OSSemPend()`.

`OSSemPost()` checks to see if any tasks are waiting for the semaphore. If not, `OSSemPost()` simply increments `p_sem->Ctr`, saves the timestamp in the semaphore, and returns.

If there are tasks waiting for the semaphore to be released, `OSSemPost()` extracts the highest-priority task waiting for the semaphore. This is a fast operation as the pend list is sorted by priority order.

When calling `OSSemPost()`, it is possible to specify as an option to not call the scheduler. This means that the post is performed, but the scheduler is not called even if a higher priority task waits for the semaphore to be released. This allows the calling task to perform other post functions (if needed) and make all posts take effect simultaneously without the possibility of context switching in between each post.

### 13-3-5 PRIORITY INVERSIONS

Priority inversion is a problem in real-time systems, and occurs only when using a priority-based preemptive kernel. Figure 13-4 illustrates a priority-inversion scenario. Task H (high priority) has a higher priority than Task M (medium priority), which in turn has a higher priority than Task L (low priority).

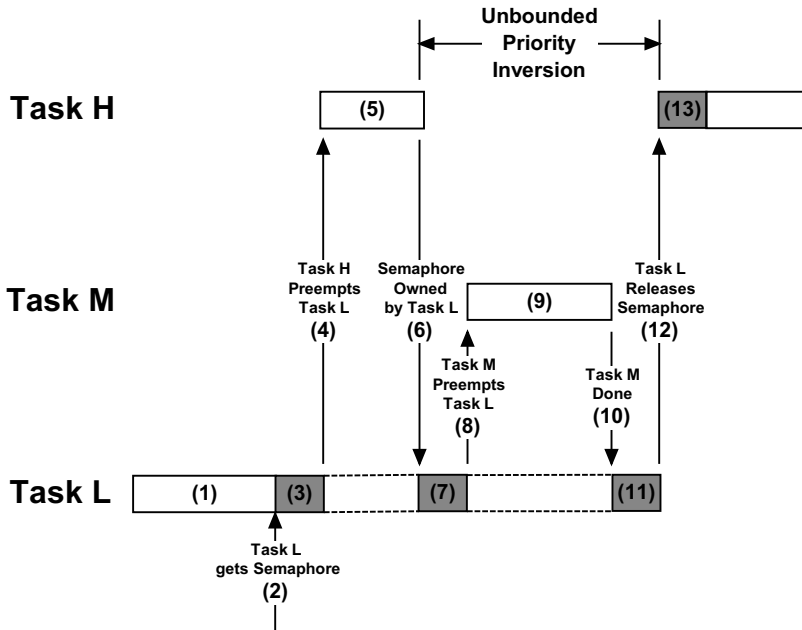

Figure 13-4 Unbounded priority Inversion

- F13-4(1) Task H and Task M are both waiting for an event to occur and Task L is executing.
- F13-4(2) At some point, Task L acquires a semaphore, which it needs before it can access a shared resource.
- F13-4(3) Task L performs operations on the acquired resource.
- F13-4(4) The event that Task H was waiting for occurs, and the kernel suspends Task L and start executing Task H since Task H has a higher priority.
- F13-4(5) Task H performs computations based on the event it just received.

- F13-4(6) Task H now wants to access the resource that Task L currently owns (i.e., it attempts to get the semaphore that Task L owns). Because Task L owns the resource, Task H is placed in a list of tasks waiting for the semaphore to be free.
- F13-4(7) Task L is resumed and continues to access the shared resource.
- F13-4(8) Task L is preempted by Task M since the event that Task M was waiting for occurred.
- F13-4(9) Task M handles the event.
- F13-4(10) When Task M completes, the kernel relinquishes the CPU back to Task L.
- F13-4(11) Task L continues accessing the resource.
- F13-4(12) Task L finally finishes working with the resource and releases the semaphore. At this point, the kernel knows that a higher-priority task is waiting for the semaphore, and a context switch takes place to resume Task H.
- F13-4(13) Task H has the semaphore and can access the shared resource.

So, what happened here is that the priority of Task H has been reduced to that of Task L since it waited for the resource that Task L owned. The trouble begins when Task M preempted Task L, further delaying the execution of Task H. This is called an *unbounded priority inversion*. It is unbounded because any medium priority can extend the time Task H has to wait for the resource. Technically, if all medium-priority tasks have known worst-case periodic behavior and bounded execution times, the priority inversion time is computable. This process, however, may be tedious and would need to be revised every time the medium priority tasks change.

This situation can be corrected by raising the priority of Task L, only during the time it takes to access the resource, and restore the original priority level when the task is finished. The priority of Task L should be raised up to the priority of Task H.  $\mu\text{C}/\text{OS-III}$  contains a special type of semaphore that does just that called a mutual-exclusion semaphore.

### 13-4 MUTUAL EXCLUSION SEMAPHORES (MUTEX)

μC/OS-III supports a special type of binary semaphore called a mutual exclusion semaphore (also known as a mutex) that eliminates unbounded priority inversions. Figure 13-5 shows how priority inversions are bounded using a Mutex.

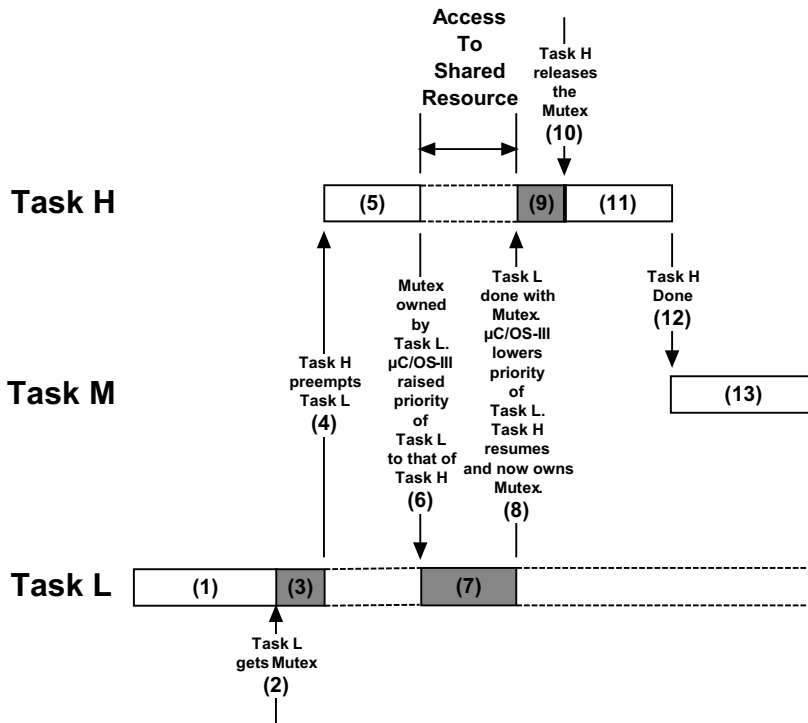

Figure 13-5 Using a mutex to share a resource

- F13-5(1) Task H and Task M are both waiting for an event to occur and Task L is executing.
- F13-5(2) At some point, Task L acquires a mutex, which it needs before it is able to access a shared resource.
- F13-5(3) Task L performs operations on the acquired resource.
- F13-5(4) The event that Task H waited for occurs and the kernel suspends Task L and begins executing Task H since Task H has a higher priority.

- F13-5(5) Task H performs computations based on the event it just received.
- F13-5(6) Task H now wants to access the resource that Task L currently owns (i.e., it attempts to get the mutex from Task L). Given that Task L owns the resource,  $\mu\text{C}/\text{OS-III}$  raises the priority of Task L to the same priority as Task H to allow Task L to finish with the resource and prevent Task L from being preempted by medium-priority tasks.
- F13-5(7) Task L continues accessing the resource, however it now does so while it is running at the same priority as Task H. Note that Task H is not actually running since it is waiting for Task L to release the mutex. In other words, Task H is in the mutex wait list.
- F13-5(8) Task L finishes working with the resource and releases the mutex.  $\mu\text{C}/\text{OS-III}$  notices that Task L was raised in priority and thus lowers Task L to its original priority. After doing so,  $\mu\text{C}/\text{OS-III}$  gives the mutex to Task H, which was waiting for the mutex to be released.
- F13-5(9) Task H now has the mutex and can access the shared resource.
- F13-5(10) Task H is finished accessing the shared resource, and frees up the mutex.
- F13-5(11) There are no higher-priority tasks to execute, therefore Task H continues execution.
- F13-5(12) Task H completes and decides to wait for an event to occur. At this point,  $\mu\text{C}/\text{OS-III}$  resumes Task M, which was made ready to run while Task H or Task L were executing.
- F13-5(13) Task M executes.

Note that there is no priority inversion, only resource sharing. Of course, the faster Task L accesses the shared resource and frees up the mutex, the better.

$\mu\text{C}/\text{OS-III}$  implements full-priority inheritance and therefore if a higher priority requests the resource, the priority of the owner task will be raised to the priority of the new requestor.

A mutex is a kernel object defined by the `OS_MUTEX` data type, which is derived from the structure `os_mutex` (see `OS.H`). An application may have an unlimited number of mutexes (limited only by the RAM available).

Only tasks are allowed to use mutual exclusion semaphores (ISRs are not allowed).

$\mu$ C/OS-III enables the user to nest ownership of mutexes. If a task owns a mutex, it can own the same mutex up to 250 times. The owner must release the mutex an equivalent number of times. In several cases, an application may not be immediately aware that it called `OSMutexPend()` multiple times, especially if the mutex is acquired again by calling a function as shown in Listing 13-12.

```
OS_MUTEX          MyMutex;
SOME_STRUCT       MySharedResource;

void MyTask (void *p_arg)
{
    OS_ERR  err;
    CPU_TS  ts;

    :
    while (DEF_ON) {
        OSMutexPend((OS_MUTEX *)&MyMutex,           (1)
                    (OS_TICK  )0,
                    (OS_OPT   )OS_OPT_PEND_BLOCKING,
                    (CPU_TS   *)&ts,
                    (OS_ERR   *)&err);

        /* Check 'err'                                     */ (2)
        /* Acquire shared resource if no error            */ (3)
        MyLibFunction();
        OSMutexPost((OS_MUTEX *)&MyMutex,           (7)
                    (OS_OPT   )OS_OPT_POST_NONE,
                    (OS_ERR   *)&err);

        /* Check "err"                                    */
    }
}
```

```
void MyLibFunction (void)
{
    OS_ERR  err;
    CPU_TS  ts;

    OSMutexPend((OS_MUTEX *)&MyMutex,                (4)
                (OS_TICK  )0,
                (OS_OPT   )OS_OPT_PEND_BLOCKING,
                (CPU_TS   *)&ts,
                (OS_ERR   *)&err);
    /* Check "err" */
    /* Access shared resource if no error */          (5)
    OSMutexPost((OS_MUTEX *)&MyMutex,                (6)
                (OS_OPT   )OS_OPT_POST_NONE,
                (OS_ERR   *)&err);
    /* Check "err" */
}
```

Listing 13-12 Nesting calls to OSMutexPend()

- L13-12(1) A task starts by pending on a mutex to access shared resources. `OSMutexPend()` sets a nesting counter to 1.
- L13-12(2) Check the error return value. If no errors exist, `MyTask()` owns `MySharedResource`.
- L13-12(3) A function is called that will perform additional work.
- L13-12(4) The designer of `MyLibFunction()` knows that, to access `MySharedResource`, it must acquire the mutex. Since the calling task already owns the mutex, this operation should not be necessary. However, `MyLibFunction()` could have been called by yet another function that might not need access to `MySharedResource`. `μC/OS-III` allows nested mutex pends, so this is not a problem. The mutex nesting counter is thus incremented to 2.
- L13-12(5) `MyLibFunction()` can access the shared resource.

- 
- L13-12(6) The mutex is released and the nesting counter is decremented back to 1. Since this indicates that the mutex is still owned by the same task, nothing further needs to be done, and `OSMutexPost()` simply returns. `MyLibFunction()` returns to its caller.
- L13-12(7) The mutex is released again and, this time, the nesting counter is decremented back to 0 indicating that other tasks can now acquire the mutex.

Always check the return value of `OSMutexPend()` (and any kernel call) to ensure that the function returned because you properly obtained the mutex, and not because the return from `OSMutexPend()` was caused by the mutex being deleted, or because another task called `OSMutexPendAbort()` on this mutex.

As a general rule, do not make function calls in critical sections. All mutual exclusion semaphore calls should be in the leaf nodes of the source code (e.g., in the low level drivers that actually touches real hardware or in other reentrant function libraries).

There are a number of operations that can be performed on a mutex, as summarized in Table 13-3. However, in this chapter, we will only discuss the three functions that most often used: `OSMutexCreate()`, `OSMutexPend()`, and `OSMutexPost()`. Other functions are described in Appendix A, “ $\mu$ C/OS-III API Reference Manual” on page 375.

| Function Name                   | Operation                  |
|---------------------------------|----------------------------|
| <code>OSMutexCreate()</code>    | Create a mutex.            |
| <code>OSMutexDel()</code>       | Delete a mutex.            |
| <code>OSMutexPend()</code>      | Wait on a mutex.           |
| <code>OSMutexPendAbort()</code> | Abort the wait on a mutex. |
| <code>OSMutexPost()</code>      | Release a mutex.           |

Table 13-3 **Mutex API summary**



### 13-4-1 MUTUAL EXCLUSION SEMAPHORE INTERNALS

A mutex is a kernel object defined by the `OS_MUTEX` data type, which is derived from the structure `os_mutex` (see `OS.H`) as shown in Listing 13-13:

```
typedef struct os_mutex OS_MUTEX;           (1)

struct os_mutex {
    OS_OBJ_TYPE      Type;                  (2)
    CPU_CHAR         *NamePtr;             (3)
    OS_PEND_LIST     PendList;            (4)
    OS_TCB           *OwnerTCBPtr;        (5)
    OS_PRIO          OwnerOriginalPrio;    (6)
    OS_NESTING_CTR   OwnerNestingCtr;     (7)
    CPU_TS           TS;                   (8)
};
```

Listing 13-13 `OS_MUTEX` data type

- L13-13(1) In  $\mu$ C/OS-III, all structures are given a data type. All data types begin with “OS\_” and are uppercase. When a mutex is declared, simply use `OS_MUTEX` as the data type of the variable used to declare the mutex.
- L13-13(2) The structure starts with a “Type” field, which allows it to be recognized by  $\mu$ C/OS-III as a mutex. Other kernel objects may also have a “.Type” as the first member of the structure. If a function is passed a kernel object,  $\mu$ C/OS-III will be able to confirm that it is being passed the proper data type. For example, if passing a message queue (`OS_Q`) to a mutex service (for example `OSMutexPend()`),  $\mu$ C/OS-III will recognize that the application passed an invalid object and return an error code accordingly.
- L13-13(3) Each kernel object can be given a name to make them easier to recognize by debuggers or  $\mu$ C/Probe. This member is simply a pointer to an ASCII string, which is assumed to be `NUL` terminated.
- L13-13(4) Because it is possible for multiple tasks to wait (or pend on a mutex), the mutex object contains a pend list as described in Chapter 10, “Pend Lists (or Wait Lists)” on page 177.

- L13-13(5) If the mutex is owned by a task, it will point to the `OS_TCB` of that task.
- L13-13(6) If the mutex is owned by a task, this field contains the “original” priority of the task that owns the mutex. This field is required in case the priority of the task must be raised to a higher priority to prevent unbounded priority inversions.
- L13-13(7)  $\mu$ C/OS-III allows a task to “acquire” the same mutex multiple times. In order for the mutex to be released, the owner must release the mutex the same number of times that it was acquired. Nesting can be performed up to 250-levels deep.
- L13-13(8) A mutex contains a timestamp, used to indicate the last time it was released.  $\mu$ C/OS-III assumes the presence of a free-running counter that allows applications to make time measurements. When the mutex is released, the free-running counter is read and the value is placed in this field, which is returned when `OSMutexPend()` returns.

Application code should never access any of the fields in this data structure directly. Instead, always use the APIs provided with  $\mu$ C/OS-III.

A mutual exclusion semaphore (mutex) must be created before it can be used by an application. Listing 13-14 shows how to create a mutex.

```
OS_MUTEX MyMutex;                                (1)

void MyTask (void *p_arg)
{
    OS_ERR err;
    :
    :
    OSMutexCreate(&MyMutex,                        (2)
                  "My Mutex",                      (3)
                  &err);                           (4)
    /* Check "err" */
    :
    :
}
```

Listing 13-14 **Creating a mutex**

- L13-14(1) The application must declare a variable of type `OS_MUTEX`. This variable will be referenced by other mutex services.
- L13-14(2) Create a mutex by calling `OSMutexCreate()` and pass the address to the mutex allocated in (1).
- L13-14(3) Assign an ASCII name to the mutex, which can be used by debuggers or  $\mu$ C/Probe to easily identify this mutex. There are no practical limits to the length of the name since  $\mu$ C/OS-III stores a pointer to the ASCII string, and not to the actual characters that makes up the string.
- L13-14(4) `OSMutexCreate()` returns an error code based on the outcome of the call. If all the arguments are valid, err will contain `OS_ERR_NONE`.

Note that since a mutex is always a binary semaphore, there is no need to initialize a mutex counter.

A task waits on a mutual exclusion semaphore before accessing a shared resource by calling `OSMutexPend()` as shown in Listing 13-15 (see Appendix A, “ $\mu$ C/OS-III API Reference Manual” on page 375 for details regarding the arguments).

```
OS_MUTEX MyMutex;

void MyTask (void *p_arg)
{
    OS_ERR err;
    CPU_TS ts;
    :
    while (DEF_ON) {
        :
        OSMutexPend(&MyMutex,          /* (1) Pointer to mutex          */
                   10,                /* Wait up until this time for the mutex */
                   OS_OPT_PEND_BLOCKING, /* Option(s)                    */
                   &ts,               /* Timestamp of when mutex was released */
                   &err);            /* Pointer to Error returned      */
        :
        /* Check "err"                (2) */
        :
        OSMutexPost(&MyMutex,         /* (3) Pointer to mutex          */
                   OS_OPT_POST_NONE, /*                               */
                   &err);            /* Pointer to Error returned      */
        /* Check "err"                */
        :
        :
    }
}
```

Listing 13-15 Pending (or waiting) on a Mutual Exclusion Semaphore

- L13-15(1) When called, `OSMutexPend()` starts by checking the arguments passed to this function to make sure they have valid values.

If the mutex is available, `OSMutexPend()` assumes the calling task is now the owner of the mutex and stores a pointer to the task's `OS_TCB` in `p_mutex->OwnerTCPPtr`, saves the priority of the task in `p_mutex->OwnerOriginalPrio`, and sets a mutex nesting counter to 1. `OSMutexPend()` then returns to its caller with an error code of `OS_ERR_NONE`.

If the task that calls `OSMutexPend()` already owns the mutex, `OSMutexPend()` simply increments a nesting counter. Applications can nest calls to `OSMutexPend()` up to 250-levels deep. In this case, the error returned will indicate `OS_ERR_MUTEX_OWNER`.

If the mutex is already owned by another task and `OS_OPT_PEND_NON_BLOCKING` is specified, `OSMutexPend()` returns since the task is not willing to wait for the mutex to be released by its owner.

If the mutex is owned by a lower-priority task,  $\mu\text{C}/\text{OS-III}$  will raise the priority of the owner to match the priority of the current task.

If specifying `OS_OPT_PEND_BLOCKING` as the option, the calling task will be inserted in the list of tasks waiting for the mutex to be available. The task is inserted in the list by priority order and the highest priority task waiting on the mutex is at the beginning of the list.

If further specifying a non-zero timeout, the task will also be inserted in the tick list. A zero value for a timeout indicates a willingness to wait forever for the mutex to be released.

The scheduler is then called since the current task is no longer able to run (it is waiting for the mutex to be released). The scheduler will then run the next highest-priority task that is ready to run.

When the mutex is finally released and the task that called `OSMutexPend()` is again the highest-priority task, a task status is examined to determine the reason why `OSMutexPend()` is returning to its caller. The possibilities are:

- 1) The mutex was given to the waiting task
- 2) The pend was aborted by another task
- 3) The mutex was not posted within the specified timeout
- 4) The mutex was deleted

When `OSMutexPend()` returns, the caller is notified of the outcome through an appropriate error code.

L13-15(2) If `OSMutexPend()` returns with `err` set to `OS_ERR_NONE`, assume that the calling task now owns the resource and can proceed with accessing it. If `err` contains anything else, then `OSMutexPend()` either timed out (if the timeout argument was non-zero), the pend was aborted by another task, or the mutex was deleted by another task. It is always important to examine returned error codes and not assume everything went as planned.

If “`err`” is `OS_ERR_NESTING_OWNER`, then the caller attempted to pend on the same mutex.

L13-15(3) When your task is finished accessing the resource, it must call `OSMutexPost()` and specify the same mutex. Again, `OSMutexPost()` starts by checking the arguments passed to this function to make sure they contain valid values.

`OSMutexPost()` now calls `OS_TS_GET()` to obtain the current timestamp and place that information in the mutex, which will be used by `OSMutexPend()`.

`OSMutexPost()` decrements the nesting counter and, if still non-zero, `OSMutexPost()` returns to the caller. In this case, the current owner has not fully released the mutex. The error code will indicate `OS_ERR_MUTEX_NESTING`.

If there are no tasks waiting for the mutex, `OSMutexPost()` sets `p_mutex->OwnerTCBPtr` to a `NULL` pointer and clears the mutex nesting counter.

If  $\mu\text{C}/\text{OS-III}$  had to raise the priority of the mutex owner, it is returned to its original priority at this time.

The highest-priority task waiting on the mutex is then extracted from the pend list and given the mutex. This is a fast operation since the pend list is sorted by priority.

The scheduler is called to see if the new mutex owner has a higher priority than the current task. If so,  $\mu\text{C}/\text{OS-III}$  will switch context to the new mutex owner.

You should note that you should only acquire one mutex at a time. In fact, it's highly recommended that when you acquire a mutex, you don't acquire any other kernel objects.

### 13-5 SHOULD YOU USE A SEMAPHORE INSTEAD OF A MUTEX?

A semaphore can be used instead of a mutex if none of the tasks competing for the shared resource have deadlines to be satisfied.

However, if there are deadlines to meet, you should use a mutex prior to accessing shared resources. Semaphores are subject to unbounded priority inversions, while mutex are not.

### 13-6 DEADLOCKS (OR DEADLY EMBRACE)

A *deadlock*, also called a **deadly embrace**, is a situation in which two tasks are each unknowingly waiting for resources held by the other.

Assume Task T1 has exclusive access to Resource R1 and Task T2 has exclusive access to Resource R2 as shown in the pseudo-code of Listing 13-16.

```
void T1 (void *p_arg)
{
    while (DEF_ON) {
        Wait for event to occur;           (1)
        Acquire M1;                       (2)
        Access R1;                       (3)
        :
        :
        \----- Interrupt!             (4)
        :
        :                                 (8)
        Acquire M2;                       (9)
        Access R2;
    }
}
```

```
void T2 (void *p_arg)
{
    while (DEF_ON) {
        Wait for event to occur;           (5)
        Acquire M2;                       (6)
        Access R2;
        :
        :
        Acquire M1;                       (7)
        Access R1;
    }
}
```

Listing 13-16 **Deadlock problem**

- L13-16(1) Assume that the event that task T1 is waiting for occurs and T1 is now the highest priority task that must execute.
- L13-16(2) Task T1 executes and acquires M1.
- L13-16(3) Resource R1 is accessed.
- L13-16(4) An interrupt occurs causing the CPU to switch to task T2 as T2 is now the highest-priority task. Actually, this could be a blocking call when the task is suspended and the CPU is given to another task.
- L13-16(5) The ISR is the event that task T2 was waiting for and therefore T2 resumes execution.
- L13-16(6) Task T2 acquires mutex M2 and is able to access resource R2.
- L13-16(7) Task T2 tries to acquire mutex M1, but  $\mu$ C/OS-III knows that mutex M1 is owned by another task.
- L13-16(8)  $\mu$ C/OS-III switches back to task T1 because Task T2 can no longer continue. It needs mutex M1 to access resource R1.
- L13-16(9) Task T1 now tries to access mutex M2 but, unfortunately, mutex M2 is owned by task T2. At this point, the two tasks are deadlocked.



Techniques used to avoid deadlocks are for tasks to:

- Never acquire more than one mutex at a time
- Never acquire a mutex directly (i.e., let them be hidden inside drivers and reentrant library calls)
- Acquire all resources before proceeding
- Always acquire resources in the same order

$\mu$ C/OS-III allows the calling task to specify a timeout when acquiring a semaphore or a mutex. This feature allows a deadlock to be broken, but the same deadlock may then recur later, or many times later. If the semaphore or mutex is not available within a certain period of time, the task requesting the resource resumes execution.  $\mu$ C/OS-III returns an error code indicating that a timeout occurred. A return error code prevents the task from thinking it has properly obtained the resource.

The pseudo-code avoids deadlocks by first acquiring all resources as shown in Listing 13-17.

```
void T1 (void *p_arg)
{
    while (DEF_ON) {
        Wait for event to occur;
        Acquire M1;
        Acquire M2;
        Access R1;
        Access R2;
    }
}

void T2 (void *p_arg)
{
    while (DEF_ON) {
        Wait for event to occur;
        Acquire M1;
        Acquire M2;
        Access R1;
        Access R2;
    }
}
```

Listing 13-17 **Deadlock avoidance – acquire all first and in the same order**

The pseudo-code to acquire all of the mutexes in the same order is shown in Listing 13-18. This is similar to the previous example, except that it is not necessary to acquire all the mutexes first, only to make sure that the mutexes are acquired in the same order for both tasks.

```
void T1 (void *p_arg){
    while (DEF_ON) {
        Wait for event to occur;
        Acquire M1;
        Access R1;
        Acquire M2;
        Access R2;
    }
}

void T2 (void *p_arg)
{
    while (DEF_ON) {
        Wait for event to occur;
        Acquire M1;
        Access R1;
        Acquire M2;
        Access R2;
    }
}
```

Listing 13-18 **Deadlock avoidance – acquire in the same order**

## 13-7 SUMMARY

The mutual exclusion mechanism used depends on how fast code will access the shared resource, as shown in Table 13-4.

| <b>Resource Sharing Method</b>  | <b>When should you use?</b>  |
|---------------------------------|--|
| Disable/Enable Interrupts       | <p>When access to shared resource is very quick (reading from or writing to just a few variables) and the access is actually faster than <math>\mu\text{C}/\text{OS-III}</math>'s interrupt disable time.</p> <p>It is highly recommended to not use this method as it impacts interrupt latency.</p>  |
| Locking/Unlocking the Scheduler | <p>When access time to the shared resource is longer than <math>\mu\text{C}/\text{OS-III}</math>'s interrupt disable time, but shorter than <math>\mu\text{C}/\text{OS-III}</math>'s scheduler lock time.</p> <p>Locking the scheduler has the same effect as making the task that locks the scheduler the highest priority task.</p> <p>It is recommended to not use this method since it defeats the purpose of using <math>\mu\text{C}/\text{OS-III}</math>. However, it's a better method than disabling interrupts as it does not impact interrupt latency.</p> |
| Semaphores                      | <p>When all tasks that need to access a shared resource do not have deadlines. This is because semaphores can cause unbounded priority inversions. However, semaphore services are slightly faster (in execution time) than mutual exclusion semaphores.</p>   |
| Mutual Exclusion Semaphores     | <p>This is the preferred method for accessing shared resources, especially if the tasks that need to access a shared resource have deadlines.</p> <p>Remember that mutual exclusion semaphores have a built-in priority inheritance mechanism, which avoids unbounded priority inversions.</p> <p>However, mutual exclusion semaphore services are slightly slower (in execution time) than semaphores, because the priority of the owner may need to be changed, which requires CPU processing.</p>   |

Table 13-4 **Resource sharing summary**

Chapter

# 14

## Synchronization

This chapter focuses on how tasks can synchronize their activities with Interrupt Service Routines (ISRs), or other tasks.

When an ISR executes, it can signal a task telling the task that an event of interest has occurred. After signaling the task, the ISR exits and, depending on the signaled task priority, the scheduler is run. The signaled task may then service the interrupting device, or otherwise react to the event. Serving interrupting devices from task level is preferred whenever possible, since it reduces the amount of time that interrupts are disabled and the code is easier to debug.

There are two basic mechanisms for synchronizations in  $\mu\text{C}/\text{OS-III}$ : semaphores and event flags.

## 14-1 SEMAPHORES

As defined in Chapter 13, “Resource Management” on page 209, a semaphore is a protocol mechanism offered by most multitasking kernels. Semaphores were originally used to control access to shared resources. However, better mechanisms exist to protect access to shared resources, as described in Chapter 12. Semaphores are best used to synchronize an ISR to a task, or synchronize a task with another task as shown in Figure 14-1.

Note that the semaphore is drawn as a flag to indicate that it is used to signal the occurrence of an event. The initial value for the semaphore is typically zero (0), indicating the event has not yet occurred.

The value “N” next to the flag indicates that the semaphore can accumulate events or credits. It is possible to initialize the semaphore with a value other than zero, indicating that the semaphore initially contains that number of events. An ISR (or a task) can post (or signal) multiple times to a semaphore and the semaphore will remember how many times it was posted.

Also, the small hourglass close to the receiving task indicates that the task has an option to specify a timeout. This timeout indicates that the task is willing to wait for the semaphore to be signaled (or posted to) within a certain amount of time. If the semaphore is not signaled within that time,  $\mu\text{C}/\text{OS-III}$  resumes the task and returns an error code indicating that the task was made ready to run because of a timeout and not the semaphore was signaled.

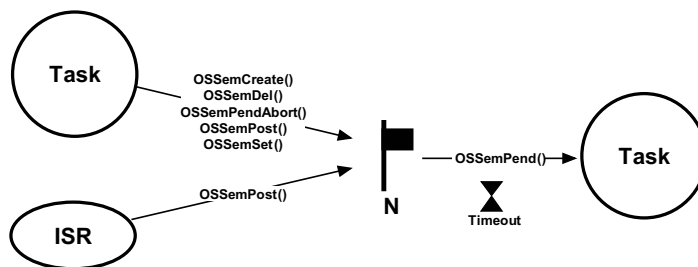

Figure 14-1  $\mu\text{C}/\text{OS-III}$  Semaphore Services

There are a number of operations to perform on semaphores as summarized in Table 14-1 and Figure 14-1. However, in this chapter, we will only discuss the three functions used most often: `OSSemCreate()`, `OSSemPend()`, and `OSSemPost()`. The other functions are described in Appendix A, “ $\mu\text{C}/\text{OS-III}$  API Reference Manual” on page 375. Also note that every semaphore function is callable from a task, but only `OSSemPost()` can be called by an ISR.

---

| Function Name    | Operation                                     |
|------------------|---|
| OSSemCreate()    | Create a semaphore.                           |
| OSSemDel()       | Delete a semaphore.                           |
| OSSemPend()      | Wait on a semaphore.                          |
| OSSemPendAbort() | Abort the wait on a semaphore.                |
| OSSemPost()      | Signal a semaphore.                           |
| OSSemSet()       | Force the semaphore count to a desired value. |

Table 14-1 Semaphore API summary

When used for synchronization, a semaphore keeps track of how many times it was signaled using a counter. The counter can take values between 0 and 255, 65,535, or 4,294,967,295, depending on whether the semaphore mechanism is implemented using 8, 16, or 32 bits, respectively. For  $\mu$ C/OS-III, the maximum value of a semaphore is determined by the data type `OS_SEM_CTR` (see `OS_TYPE.H`), which is changeable, as needed (assuming access to  $\mu$ C/OS-III's source code). Along with the semaphore's value,  $\mu$ C/OS-III keeps track of tasks waiting for the semaphore to be signaled.

### 14-1-1 UNILATERAL RENDEZVOUS

Figure 14-2 shows that a task can be synchronized with an ISR (or another task) by using a semaphore. In this case, no data is exchanged, however there is an indication that the ISR or the task (on the left) has occurred. Using a semaphore for this type of synchronization is called a unilateral rendezvous.

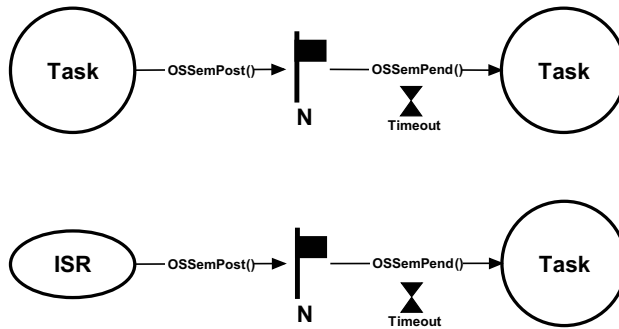

Figure 14-2 Unilateral Rendezvous

A unilateral rendezvous is used when a task initiates an I/O operation and waits (i.e., call `OSSemPend()`) for the semaphore to be signaled (posted). When the I/O operation is complete, an ISR (or another task) signals the semaphore (i.e., calls `OSSemPost()`), and the task is resumed. This process is also shown on the timeline of Figure 14-3 and described below. The code for the ISR and task is shown in Listing 14-1.

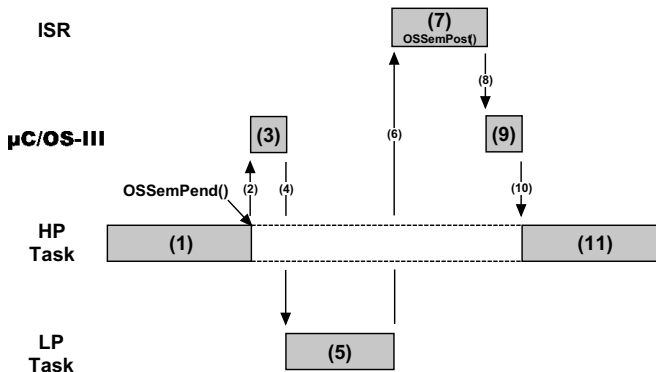

Figure 14-3 Unilateral Rendezvous, Timing Diagram



- 
- F14-3(1) A high priority task is executing. The task needs to synchronize with an ISR (i.e., wait for the ISR to occur) and call `OSSemPend()`.
- F14-3(2)
- F14-3(3)
- F14-3(4) Since the ISR has not occurred, the task will be placed in the waiting list for the semaphore until the event occurs. The scheduler in  $\mu\text{C}/\text{OS-III}$  will then select the next most important task and context switch to that task.
- F14-3(5) The low-priority task executes.
- F14-3(6) The event that the original task was waiting for occurs. The lower-priority task is immediately preempted (assuming interrupts are enabled), and the CPU vectors to the interrupt handler for the event.
- F14-3(7)
- F14-3(8) The ISR handles the interrupting device and then calls `OSSemPost()` to signal the semaphore. When the ISR completes,  $\mu\text{C}/\text{OS-III}$  is called.
- F14-3(9)
- F14-3(10)  $\mu\text{C}/\text{OS-III}$  notices that a higher-priority task is waiting for this event to occur and context switches back to the original task.
- F14-3(11) The original task resumes execution immediately after the call to `OSSemPend()`.

```
OS_SEM MySem;

void MyISR (void)
{
    OS_ERR err;

    /* Clear the interrupting device */
    OSSemPost(&MySem,                (7)
              OS_OPT_POST_1,
              &err);
    /* Check "err" */
}

void MyTask (void *p_arg)
{
    OS_ERR err;
    CPU_TS ts;
    :
    :
    while (DEF_ON) {
        OSSemPend(&MySem,            (1)
                 10,
                 OS_OPT_PEND_BLOCKING,
                 &ts,
                 &err);
        /* Check "err" */            (11)
        :
        :
    }
}
```

Listing 14-1 Pending (or waiting) on a Semaphore

A few interesting things are worth noting about this process. First, the task does not need to know about the details of what happens behind the scenes. As far as the task is concerned, it called a function (`OSSemPend()`) that will return when the event it is waiting for occurs. Second,  $\mu\text{C}/\text{OS-III}$  maximizes the use of the CPU by selecting the next most important task, which executes until the ISR occurs. In fact, the ISR may not occur for many milliseconds and, during that time, the CPU will work on other tasks. As far as the task that is waiting for the semaphore is concerned, it does not consume CPU time while it is waiting. Finally, the task waiting for the semaphore will execute immediately after the event occurs (assuming it is the most important task that needs to run).

## 14-1-2 CREDIT TRACKING

As previously mentioned, a semaphore “remembers” how many times it was signaled (or posted to). In other words, if the ISR occurs multiple times before the task waiting for the event becomes the highest-priority task, the semaphore will keep count of the number of times it was signaled. When the task becomes the highest priority ready-to-run task, it will execute without blocking as many times as there were ISRs signaled. This is called Credit Tracking and is illustrated in Figure 14-4 and described below.

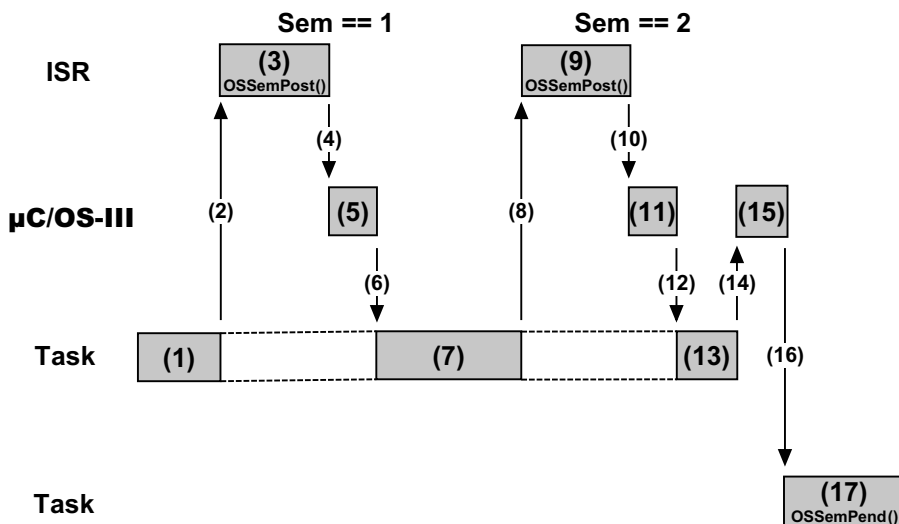

Figure 14-4 Semaphore Credit Tracking

F14-4(1) A high-priority task is executing.

F14-4(2)

F14-4(3) An event meant for a lower-priority task occurs which preempts the task (assuming interrupts are enabled). The ISR executes and posts the semaphore. At this point the semaphore count is 1.

F14-4(4)

F14-4(5)

F14-4(6) μC/OS-III is called at the end of the ISR to see if the ISR caused a higher-priority task to be ready to run. Since the ISR was an event that a lower-priority task was waiting on, μC/OS-III will resume execution of the higher-priority task at the exact point where it was interrupted.

F14-4(7) The high-priority task is resumed and continues execution.

F14-4(8)

F14-4(9) The interrupt occurs a second time. The ISR executes and posts the semaphore. At this point the semaphore count is 2.

F14-4(10)

F14-4(11)

F14-4(12)  $\mu\text{C}/\text{OS-III}$  is called at the end of the ISR to see if the ISR caused a higher-priority task to be ready to run. Since the ISR was an event that a lower-priority task was waiting on,  $\mu\text{C}/\text{OS-III}$  resumes execution of the higher-priority task at the exact point where it was interrupted.

F14-4(13)

F14-4(14) The high-priority task resumes execution and actually terminates the work it was doing. This task will then call one of the  $\mu\text{C}/\text{OS-III}$  services to wait for “its” event to occur.

F14-4(15)

F14-4(16)  $\mu\text{C}/\text{OS-III}$  will then select the next most important task, which happens to be the task waiting for the event and will context switch to that task.

F14-4(17) The new task executes and will know that the ISR occurred twice since the semaphore count is two. The task will handle this accordingly.

### 14-1-3 MULTIPLE TASKS WAITING ON A SEMAPHORE

It is possible for more than one task to wait on the same semaphore, each with its own timeout as illustrated in Figure 14-5.

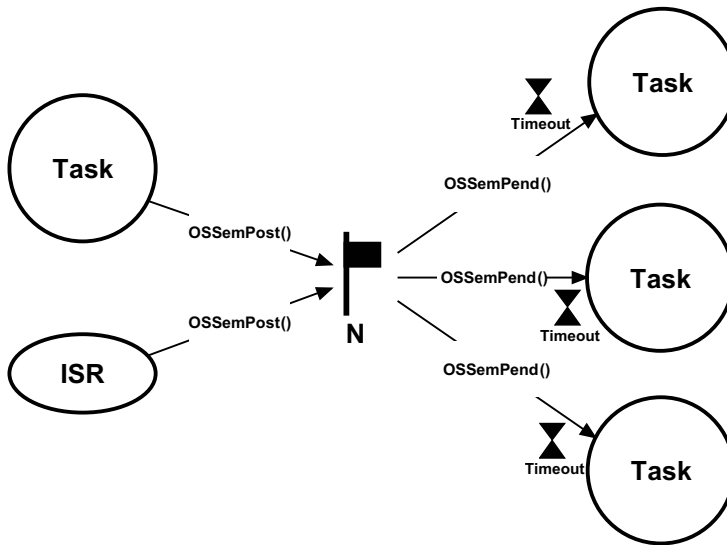

Figure 14-5 Multiple Tasks waiting on a Semaphore

When the semaphore is signaled (whether by an ISR or task),  $\mu\text{C}/\text{OS-III}$  makes the highest-priority task waiting on the semaphore ready to run. However, it is also possible to specify that all tasks waiting on the semaphore be made ready to run. This is called broadcasting and is accomplished by specifying `OS_OPT_POST_ALL` as an option when calling `OSSemPost()`. If any of the waiting tasks has a higher priority than the previously running task,  $\mu\text{C}/\text{OS-III}$  will execute the highest-priority task made ready by `OSSemPost()`.

Broadcasting is a common technique used to synchronize multiple tasks and have them start executing at the same time. However, some of the tasks that we want to synchronize might not be waiting for the semaphore. It is fairly easy to resolve this problem by combining semaphores and event flags. This will be described after examining event flags.

### **14-1-4 SEMAPHORE INTERNALS (FOR SYNCHRONIZATION)**

Note that some of the material presented in this section is also contained in Chapter 13, “Resource Management” on page 209, as semaphores were also discussed in that chapter. However, the material presented here will be applicable to semaphores used for synchronization and thus will differ somewhat.

A counting semaphore allows values between 0 and 255, 65,535, or 4,294,967,295, depending on whether the semaphore mechanism is implemented using 8, 16, or 32 bits, respectively. For  $\mu\text{C}/\text{OS-III}$ , the maximum value of a semaphore is determined by the data type `OS_SEM_CTR` (see `OS_TYPE.H`), which can be changed as needed (assuming access to  $\mu\text{C}/\text{OS-III}$ 's source code). Along with the semaphore's value,  $\mu\text{C}/\text{OS-III}$  keeps track of tasks waiting for the semaphore's availability.

The application programmer can create an unlimited number of semaphores (limited only by available RAM). Semaphore services in  $\mu\text{C}/\text{OS-III}$  start with the `OSSem???`( ) prefix, and services available to the application programmer are described in Appendix A, “ $\mu\text{C}/\text{OS-III}$  API Reference Manual” on page 375. Semaphore services are enabled at compile time by setting the configuration constant `OS_CFG_SEM_EN` to 1 in `OS_CFG.H`.

Semaphores must be created before they can be used by the application. Listing 14-3 shows how to create a semaphore.

As previously mentioned, a semaphore is a kernel object as defined by the `OS_SEM` data type, which is derived from the structure `os_sem` (see `OS.H`) as shown in Listing 14-2.

The services provided by  $\mu\text{C}/\text{OS-III}$  to manage semaphores are implemented in the file `OS_SEM.C`.  $\mu\text{C}/\text{OS-III}$  licensees, have access to the source code.

```
typedef struct os_sem OS_SEM;           (1)

struct os_sem {
    OS_OBJ_TYPE      Type;              (2)
    CPU_CHAR         *NamePtr;         (3)
    OS_PEND_LIST     PendList;         (4)
    OS_SEM_CTR       Ctr;              (5)
    CPU_TS           TS;               (6)
};
```

Listing 14-2 OS\_SEM data type

- L14-2(1) In  $\mu$ C/OS-III, all structures are given a data type. In fact, all data types start with “OS\_” and are all uppercase. When a semaphore is declared, simply use **OS\_SEM** as the data type of the variable used to declare the semaphore.
- L14-2(2) The structure starts with a “**Type**” field, which allows it to be recognized by  $\mu$ C/OS-III as a semaphore. In other words, other kernel objects will also have a “**Type**” as the first member of the structure. If a function is passed a kernel object,  $\mu$ C/OS-III will confirm that it is being passed the proper data type. For example, if passing a message queue (**OS\_Q**) to a semaphore service (for example **OSSemPend()**),  $\mu$ C/OS-III will recognize that an invalid object was passed, and return an error code accordingly.
- L14-2(3) Each kernel object can be given a name to make them easier to be recognized by debuggers or  $\mu$ C/Probe. This member is simply a pointer to an ASCII string, which is assumed to be **NUL** terminated.
- L14-2(4) Since it is possible for multiple tasks to be waiting (or pending) on a semaphore, the semaphore object contains a pend list as described in Chapter 10, “Pend Lists (or Wait Lists)” on page 177.
- L14-2(5) A semaphore contains a counter. As explained above, the counter can be implemented as either an 8-, 16- or 32-bit value, depending on how the data type **OS\_SEM\_CTR** is declared in **OS\_TYPE.H**.

$\mu$ C/OS-III keeps track of how many times the semaphore is signaled with this counter and this field is typically initialized to zero by **OSSemCreate()**.

L14-2(6) A semaphore contains a time stamp, which is used to indicate the last time the semaphore was signaled (or posted to).  $\mu$ C/OS-III assumes the presence of a free-running counter that allows the application to make time measurements. When the semaphore is signaled, the free-running counter is read and the value is placed in this field, which is returned when `OSSemPend()` is called. This value allows the application to determine either when the signal was performed, or how long it took for the task to get control of the CPU from the signal. In the latter case, call `OS_TS_GET()` to determine the current timestamp and compute the difference.

Even for users who understand the internals of the `OS_SEM` data type, the application code should never access any of the fields in this data structure directly. Instead, always use the APIs provided with  $\mu$ C/OS-III.

Semaphores must be created before they can be used by an application. Listing 14-3 shows how to create a semaphore.

```
OS_SEM MySem;                                (1)

void MyCode (void)
{
    OS_ERR err;
    :
    OSSemCreate(&MySem,                        (2)
                "My Semaphore",               (3)
                (OS_SEM_CTR)0,               (4)
                &err);                         (5)
    /* Check "err" */
    :
}
```

Listing 14-3 **Creating a Semaphore**

L14-3(1) The application must declare a variable of type `OS_SEM`. This variable will be referenced by other semaphore services.

L14-3(2) Create a semaphore by calling `OSSemCreate()` and pass the address to the semaphore allocated in (1).



- 
- L14-3(3) Assign an ASCII name to the semaphore, which can be used by debuggers or  $\mu$ C/Probe to easily identify this semaphore.
- L14-3(4) Initialize the semaphore to zero (0) when using a semaphore as a signaling mechanism.
- L14-3(5) **OSSemCreate()** returns an error code based on the outcome of the call. If all arguments are valid, `err` will contain **OS\_ERR\_NONE**.

**OSSemCreate()** performs a check on the arguments passed to this function and only initializes the contents of the variable of type **OS\_SEM** used for signaling.

A task waits for a signal from an ISR or another task by calling **OSSemPend()** as shown in Listing 14-4 (see Appendix A, “ $\mu$ C/OS-III API Reference Manual” on page 375 for details regarding the arguments).

```
OS_SEM MySem;                                (1)

void MyCode (void)
{
    OS_ERR err;
    :
    OSMemCreate(&MySem,                        (2)
                "My Semaphore",               (3)
                (OS_SEM_CTR)0,                (4)
                &err);                         (5)
    /* Check "err" */
    :
}
```

Listing 14-4 **Pending (or waiting) on a Semaphore**

- L14-4(1) When called, **OSSemPend()** starts by checking the arguments passed to this function to make sure they have valid values.

If the semaphore counter (`.Ctr` of **OS\_SEM**) is greater than zero, the counter is decremented and **OSSemPend()** returns, which indicates that the signal occurred. This is the outcome that the caller expects.

If the semaphore counter is zero, this indicates that the signal has not occurred and the calling task might need to wait for the semaphore to be released. If specifying `OS_OPT_PEND_NON_BLOCKING` as the option (the task is not to block), `OSSemPend()` returns immediately to the caller and the returned error code will indicate that the signal did not occur.

If specifying `OS_OPT_PEND_BLOCKING` as the option, the calling task will be inserted in the list of tasks waiting for the semaphore to be signaled. The task is inserted in the list by priority order with the highest priority task waiting on the semaphore at the beginning of the list as shown in Figure 14-6.

If further specifying a non-zero timeout, the task will also be inserted in the tick list. A zero value for a timeout indicates that the calling task is willing to wait forever for the semaphore to be signaled.

The scheduler is then called as the current task is not able to run (it is waiting for the semaphore to be signaled). The scheduler will then run the next highest-priority task that is ready to run.

When the semaphore is signaled and the task that called `OSSemPend()` is again the highest-priority task, a task status is examined to determine the reason why `OSSemPend()` is returning to its caller. The possibilities are:

- 1) The semaphore was signaled
- 2) The pend was aborted by another task
- 3) The semaphore was not signaled within the specified timeout
- 4) The semaphore was deleted

When `OSSemPend()` returns, the caller is notified of the above outcome through an appropriate error code.

L14-4(2) If `OSSemPend()` returns with `err` set to `OS_ERR_NONE`, assume that the semaphore was signaled and the task can proceed with servicing the ISR or task that caused the signal. If `err` contains anything else, `OSSemPend()` either timed out (if the timeout argument was non-zero), the pend was aborted by

another task, or the semaphore was deleted by another task. It is always important to examine returned error code and not assume everything went as expected.

To signal a task (either from an ISR or a task), simply call `OSSemPost()` as shown in Listing 14-5.

```
OS_SEM MySem;

void MyISR (void)
{
    OS_ERR err;
    :
    OS_SemPost(&MySem,           (1)
               OS_OPT_POST_1,   (2)
               &err);           (3)
    /* Check "err" */
    :
    :
}
```

Listing 14-5 **Posting (or signaling) a Semaphore**

L14-5(1) Your task signals (or posts to) the semaphore by calling `OS_SemPost()`. Specify the semaphore to post by passing its address. The semaphore must have been previously created.

L14-5(2) The next argument specifies how the task wants to post. There are a number of options to choose from.

Specify `OS_OPT_POST_1`, which indicates posting to only one task in case there are multiple tasks waiting on the semaphore. The task that will be made ready to run will be the highest-priority task waiting on the semaphore. If there are multiple tasks at the same priority, only one of them will be made ready-to-run. As shown in Figure 14-6, tasks waiting are in priority order (HPT means High Priority Task and LPT means Low Priority Task). It is a fast operation to extract the HPT from the list.

If specifying `OS_OPT_POST_ALL`, all tasks waiting on the semaphore will be posted and made ready to run.

The calling task can “add” the option `OS_OPT_POST_NO_SCHED` to either of the two previous options to indicate that the scheduler is not to be called at the end of `OS_SemPost()`, possibly because additional postings will be performed, and rescheduling should take place when finished. This means that the signal is performed, but the scheduler is not called even if a higher-priority task was waiting for the semaphore to be signaled. This allows the calling task to perform other post functions (if needed) and make all the posts take effect simultaneously. Note that `OS_OPT_POST_NO_SCHED` is “additive,” meaning that it can be used with either of the previous options. You can specify:

```

OS_OPT_POST_1
OS_OPT_POST_ALL
OS_OPT_POST_1 + OS_OPT_POST_NO_SCHED
OS_OPT_POST_ALL + OS_OPT_POST_NO_SCHED
    
```

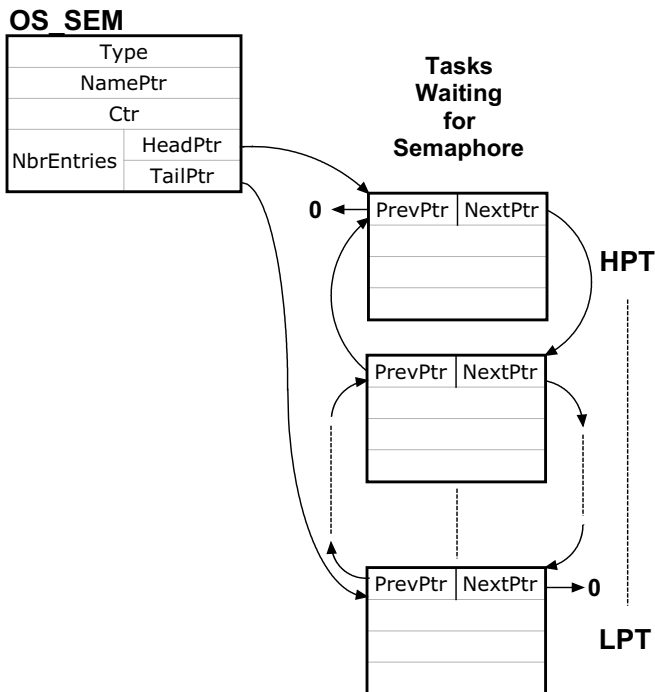

Figure 14-6 Tasks waiting for semaphore

L14-5(3) `OSSemPost()` returns an error code based on the outcome of the call. If the call was successful, `err` will contain `OS_ERR_NONE`. If not, the error code will indicate the reason for the error (see Appendix A, “ $\mu$ C/OS-III API Reference Manual” on page 375 for a list of possible error codes for `OSSemPost()`).

## 14-2 TASK SEMAPHORE

Signaling a task using a semaphore is a very popular method of synchronization and, in  $\mu$ C/OS-III, each task has its own built-in semaphore. This feature not only simplifies code, but is also more efficient than using a separate semaphore object. The semaphore, which is built into each task, is shown in Figure 14-7.

Task semaphore services in  $\mu$ C/OS-III start with the `OSTaskSem???`( ) prefix, and the services available to the application programmer are described in Appendix A, “ $\mu$ C/OS-III API Reference Manual” on page 375. Task semaphores are built into  $\mu$ C/OS-III and cannot be disabled at compile time as can other services. The code for task semaphores is found in `OS_TASK.C`.

Use this feature if the code knows which task to signal when the event occurs. For example, if receiving an interrupt from an Ethernet controller, signal the task responsible for processing the received packet as it is preferable to perform this processing using a task instead of the ISR.

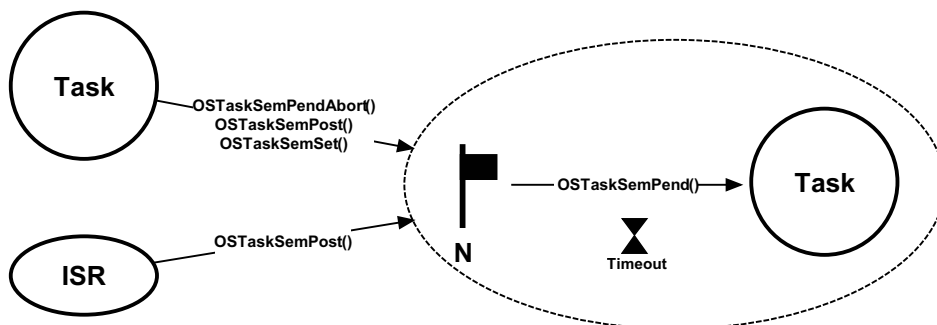

Figure 14-7 Semaphore built-into a Task

There are a number of operations to perform on task semaphores, summarized in Table 14-2.

| Function Name        | Operation                                     |
|----------------------|---|
| OSTaskSemPend()      | Wait on a task semaphore.                     |
| OSTaskSemPendAbort() | Abort the wait on a task semaphore.           |
| OSTaskSemPost()      | Signal a task.                                |
| OSTaskSemSet()       | Force the semaphore count to a desired value. |

Table 14-2 Task Semaphore API summary

### 14-2-1 PENDING (i.e., WAITING) ON A TASK SEMAPHORE

When a task is created, it automatically creates an internal semaphore with an initial value of zero (0). Waiting on a task semaphore is quite simple, as shown in Listing 14-6.

```

void MyTask (void *p_arg)
{
    OS_ERR  err;
    CPU_TS  ts;
    :
    while (DEF_ON) {
        OSTaskSemPend(10,                (1)
                     OS_OPT_PEND_BLOCKING, (2)
                     &ts,                (3)
                     &err);              (4)
        /* Check "err" */
    }
    :
    :
}

```

Listing 14-6 Pending (or waiting) on Task's internal semaphore

L14-6(1) A task pends (or waits) on the task semaphore by calling `OSTaskSemPend()`. There is no need to specify which task, as the current task is assumed. The first argument is a timeout specified in number of clock ticks. The actual timeout obviously depends on the tick rate. If the tick rate (see `OS_CFG_APP.H`) is set to 1000, a timeout of 10 ticks represents 10 milliseconds. Specifying a timeout of zero (0) means that the task will wait forever for the task semaphore.

- L14-6(2) The second argument specifies how to pend. There are two options: `OS_OPT_PEND_BLOCKING` and `OS_OPT_PEND_NON_BLOCKING`. The blocking option means that, if the task semaphore has not been signaled (or posted to), the task will wait until the semaphore is signaled, the pend is aborted by another task or, until the timeout expires.
- L14-6(3) When the semaphore is signaled,  $\mu\text{C}/\text{OS-III}$  reads a “timestamp” and places it in the receiving task’s `OS_TCB`. When `OSTaskSemPend()` returns, the value of the timestamp is placed in the local variable “`ts`”. This feature captures “when” the signal actually happened. Call `OS_TS_GET()` to read the current timestamp and compute the difference. This establishes how long it took for the task to receive the signal from the posting task or ISR.
- L14-6(4) `OSTaskSemPend()` returns an error code based on the outcome of the call. If the call was successful, `err` will contain `OS_ERR_NONE`. If not, the error code will indicate the reason of the error (see Appendix A, “ $\mu\text{C}/\text{OS-III}$  API Reference Manual” on page 375 for a list of possible error code for `OSTaskSemPend()`).

## 14-2-2 POSTING (i.e., SIGNALING) A TASK SEMAPHORE

An ISR or a task signals a task by calling `OSTaskSemPost()`, as shown in Listing 14-7.

```
OS_TCB MyTaskTCB;

void MyISR (void *p_arg)
{
    OS_ERR err;
    :
    OSTaskSemPost(&MyTaskTCB,          (1)
                  OS_OPT_POST_NONE,   (2)
                  &err);              (3)
    /* Check "err" */
    :
    :
}
```

Listing 14-7 Posting (or signaling) a Semaphore

L14-7(1) A task posts (or signals) the task by calling `OSTaskSemPost()`. It is necessary to pass the address of the desired task's `OS_TCB`. Of course, the task must exist.

L14-7(2) The next argument specifies how the user wants to post. There are only two choices.

Specify `OS_OPT_POST_NONE`, which indicates the use of the default option of calling the scheduler after posting the semaphore.

Or, specify `OS_OPT_POST_NO_SCHED` to indicate that the scheduler is not to be called at the end of `OSTaskSemPost()`, possibly because there will be additional postings, and rescheduling would take place when finished (the last post would not specify this option).

L14-7(3) `OSTaskSemPost()` returns an error code based on the outcome of the call. If the call was successful, `err` will contain `OS_ERR_NONE`. If not, the error code will indicate the reason of the error (see Appendix A, “ $\mu$ C/OS-III API Reference Manual” on page 375 for a list of possible error codes for `OSTaskSemPost()`).



### 14-2-3 BILATERAL RENDEZVOUS

Two tasks can synchronize their activities by using two task semaphores, as shown in Figure 14-8, and is called a *bilateral rendezvous*. A bilateral rendezvous is similar to a unilateral rendezvous, except that both tasks must synchronize with one another before proceeding. A bilateral rendezvous cannot be performed between a task and an ISR because an ISR cannot wait on a semaphore.

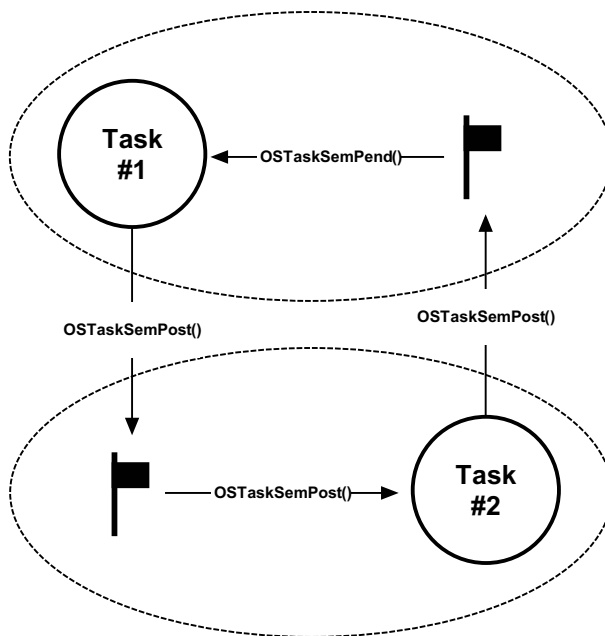

Figure 14-8 **Bilateral Rendezvous**

The code for a bilateral rendezvous is shown in Listing 14-8. Of course, a bilateral rendezvous can use two separate semaphores, but the built-in task semaphore makes setting up this type of synchronization quite straightforward.

```
OS_TCB MyTask1_TCB;
OS_TCB MyTask2_TCB;

void Task1 (void *p_arg)
{
    OS_ERR err;
    CPU_TS ts;

    while (DEF_ON) {
        :
        OSTaskSemPost(&MyTask2_TCB,           (1)
                     OS_OPT_POST_NONE,
                     &err);
        /* Check 'err' */
        OSTaskSemPend(0,                       (2)
                     OS_OPT_PEND_BLOCKING,
                     &ts,
                     &err);
        /* Check 'err' */
        :
    }
}

void Task2 (void *p_arg)
{
    OS_ERR err;
    CPU_TS ts;

    while (DEF_ON) {
        :
        OSTaskSemPost(&MyTask1_TCB,           (3)
                     OS_OPT_POST_NONE,
                     &err);
        /* Check 'err' */
        OSTaskSemPend(0,                       (4)
                     OS_OPT_PEND_BLOCKING,
                     &ts,
                     &err);
        /* Check 'err' */
        :
    }
}
```

Listing 14-8 Tasks synchronizing their activities

- L14-8(1) Task #1 is executing and signals Task #2's semaphore.
- L14-8(2) Task #1 pends on its internal semaphore to synchronize with Task #2. Because Task #2 has not executed yet, Task #1 is blocked waiting on its semaphore to be signaled.  $\mu$ C/OS-III context switches to Task #2.
- L14-8(3) Task #2 executes, and signals Task #1's semaphore.
- L14-8(4) Since it has already been signaled, Task #2 is now synchronized to Task #1. If Task #1 is higher in priority than Task #2,  $\mu$ C/OS-III will switch back to Task #1. If not, Task #2 continues execution.

### **14-3 EVENT FLAGS**

Event flags are used when a task needs to synchronize with the occurrence of multiple events. The task can be synchronized when any of the events have occurred, which is called disjunctive synchronization (logical OR). A task can also be synchronized when all events have occurred, which is called conjunctive synchronization (logical AND). Disjunctive and conjunctive synchronization are shown in Figure 14-9.

The application programmer can create an unlimited number of event flag groups (limited only by available RAM). Event flag services in  $\mu$ C/OS-III start with the `OSFlag???`( ) prefix. The services available to the application programmer are described in Appendix A, “ $\mu$ C/OS-III API Reference Manual” on page 375.

The code for event flag services is found in the file `OS_FLAG.C`, and is enabled at compile time by setting the configuration constant `OS_CFG_FLAG_EN` to 1 in `OS_CFG.H`.

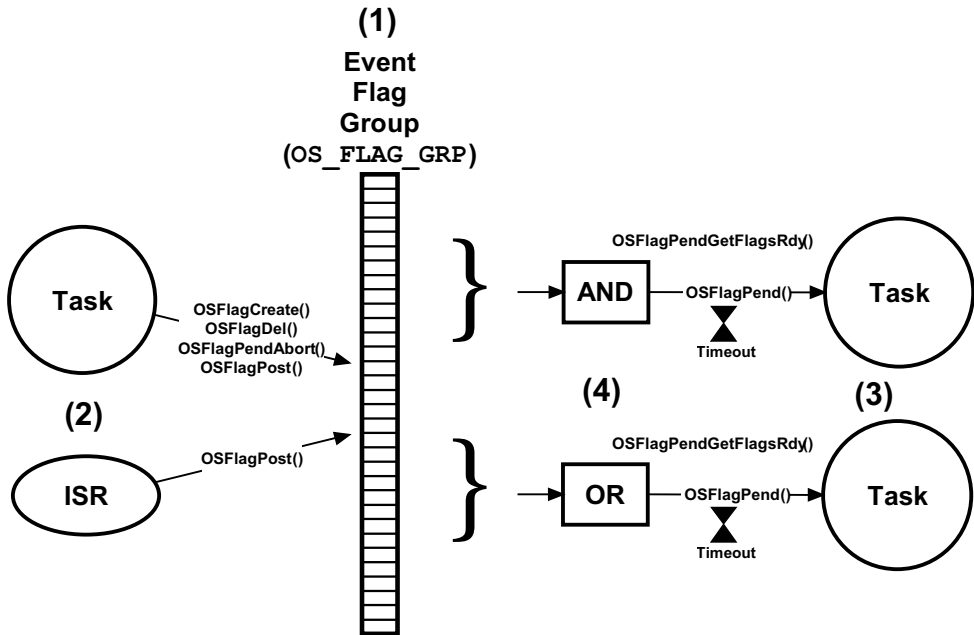

Figure 14-9 Event Flags

- F14-9(1) A  $\mu$ C/OS-III “event flag group” is a kernel object of type `OS_FLAG_GRP` (see `OS.H`), and consists of a series of bits (8-, 16- or 32-bits, based on the data type `OS_FLAGS` defined in `OS_TYPE.H`). The event flag group also contains a list of tasks waiting for some (or all) of the bits to be set (1) or clear (0). An event flag group must be created before it can be used by tasks and ISRs. Create event flags prior to starting  $\mu$ C/OS-III, or by a startup task in the application code.
- F14-9(2) Tasks or ISRs can post to event flags. In addition, only tasks can create, delete, and stop other task from pending on event flag groups.
- F14-9(3) A task can wait (i.e., pend) on any number of bits in an event flag group (i.e., a subset of all the bits). As with all  $\mu$ C/OS-III pend calls, the calling task can specify a timeout value such that if the desired bits are not posted within a specified amount of time (in ticks), the pending task is resumed and informed about the timeout.
- F14-9(4) The task can specify whether it wants to wait for “any” subset of bits (OR) to be set (or clear), or wait for “all” bits in a subset of bit (AND) to be set (or clear).

There are a number of operations to perform on event flags, as summarized in Table 14-3.

| <b>Function Name</b>                 | <b>Operation</b>                           |
|--------------------------------------|--|
| <code>OSFlagCreate()</code>          | Create an event flag group                 |
| <code>OSFlagDel()</code>             | Delete an event flag group                 |
| <code>OSFlagPend()</code>            | Pend (i.e., wait) on an event flag group   |
| <code>OSFlagPendAbort()</code>       | Abort waiting on an event flag group       |
| <code>OSFlagPendGetFlagsRdy()</code> | Get flags that caused task to become ready |
| <code>OSFlagPost()</code>            | Post flag(s) to an event flag group        |

Table 14-3 **Event Flags API summary**

### **14-3-1 USING EVENT FLAGS**

When a task or an ISR posts to an event flag group, all tasks that have their wait conditions satisfied will be resumed.

It's up to the application to determine what each bit in an event flag group means and it is possible to use as many event flag groups as needed. In an event flag group you can, for example, define that bit #0 indicates that a temperature sensor is too low, bit #1 may indicate a low battery voltage, bit #2 could indicate that a switch was pressed, etc. The code (tasks or ISRs) that detects these conditions would set the appropriate event flag by calling `OSFlagPost()` and the task(s) that would respond to those conditions would call `OSFlagPend()`.

Listing 14-9 shows how to use event flags.

```
#define    TEMP_LOW   (OS_FLAGS)0x0001           (1)
#define    BATT_LOW  (OS_FLAGS)0x0002
#define    SW_PRESSED (OS_FLAGS)0x0004

OS_FLAG_GRP MyEventFlagGrp;                    (2)

void main (void)
{
    OS_ERR  err;

    OSInit(&err);
    :
    OSFlagCreate(&MyEventFlagGrp,                (3)
                 "My Event Flag Group",
                 (OS_FLAGS)0,
                 &err);
    /* Check 'err' */
    :
    OSStart(&err);
}

void MyTask (void *p_arg)                       (4)
{
    OS_ERR  err;
    CPU_TS  ts;

    while (DEF_ON) {
        OSFlagPend(&MyEventFlagGrp,              (5)
                   TEMP_LOW + BATT_LOW,
                   (OS_TICK )0,
                   (OS_OPT)OS_OPT_PEND_FLAG_SET_ANY,
                   &ts,
                   &err);
        /* Check 'err' */
        :
    }
}
```

```

void MyISR (void)                                     (6)
{
    OS_ERR err;
    :
    OSFlagPost(&MyEventFlagGrp,                       (7)
               BAT_LOW,
               (OS_OPT)OS_OPT_POST_FLAG_SET,
               &err);
    /* Check 'err' */
    :
}

```

Listing 14-9 Using Event Flags

- L14-9(1) Define some bits in the event flag group.
- L14-9(2) Declare an object of type `OS_FLAG_GRP`. This object will be referenced in all subsequent  $\mu$ C/OS-III calls that apply to this event flag group. For the sake of discussions, assume that event flags are declared to be 16-bits in `OS_TYPE.H` (i.e., of type `CPU_INT16U`).
- L14-9(3) Event flag groups must be “created” before they can be used. The best place to do this is in your startup code as it ensures that no tasks, or ISR, will be able to use the event flag group until  $\mu$ C/OS-III is started. In other words, the best place to create the event flag group is in `main()`. In the example, the event flag was given a name and all bits start in their cleared state (i.e., all zeros).
- L14-9(4) Assume that the application created “`MyTask()`” which will be pending on the event flag group.
- L14-9(5) To pend on an event flag group, call `OSFlagPend()` and pass it the address of the desired event flag group.

The second argument specifies which bits the task will be waiting to be set (assuming the task is triggered by set bits instead of cleared bits).

Specify how long to wait for these bits to be set. A timeout value of zero (0) indicates that the task will wait forever. A non-zero value indicates the number of ticks the task will wait until it is resumed if the desired bits are not set.

Specifying `OS_OPT_FLAG_SET_ANY` indicates that the task will wake up if either of the two bits specified is set.

A timestamp is read and saved when the event flag group is posted to. This timestamp can be used to determine the response time to the event.

`OSFlagPend()` performs a number of checks on the arguments passed (i.e., did you pass `NULL` pointers, invalid options, etc.), and returns an error code based on the outcome of the call. If the call was successful “err” will be set to `OS_ERR_NONE`.

L14-9(6) An ISR (it can also be a task) is setup to detect when the battery voltage of the product goes low (assuming the product is battery operated). The ISR signals the task, letting the task perform whatever corrective action is needed.

L14-9(7) The desired event flag group is specified in the post call as well as which flag the ISR is setting. The third option specifies that the error condition will be “flagged” as a set bit. Again, the function sets “err” based on the outcome of the call.

Event flags are generally used for two purposes: status and transient events. Typically use different event flag groups to handle each of these as shown in Listing 14-10.

Tasks or ISRs can report status information such as a temperature that has exceeded a certain value, that RPM is zero on an engine or motor, or there is fuel in the tank, and more. This status information cannot be “consumed” by the tasks waiting for these events, because the status is managed by other tasks or ISRs. Event flags associated with status information are monitored by other task by using non-blocking wait calls.

Tasks will report transient events such as a switch was pressed, an object was detected by a motion sensor, an explosion occurred, etc. The task that responds to these events will typically block waiting for any of those events to occur and “consume” the event.



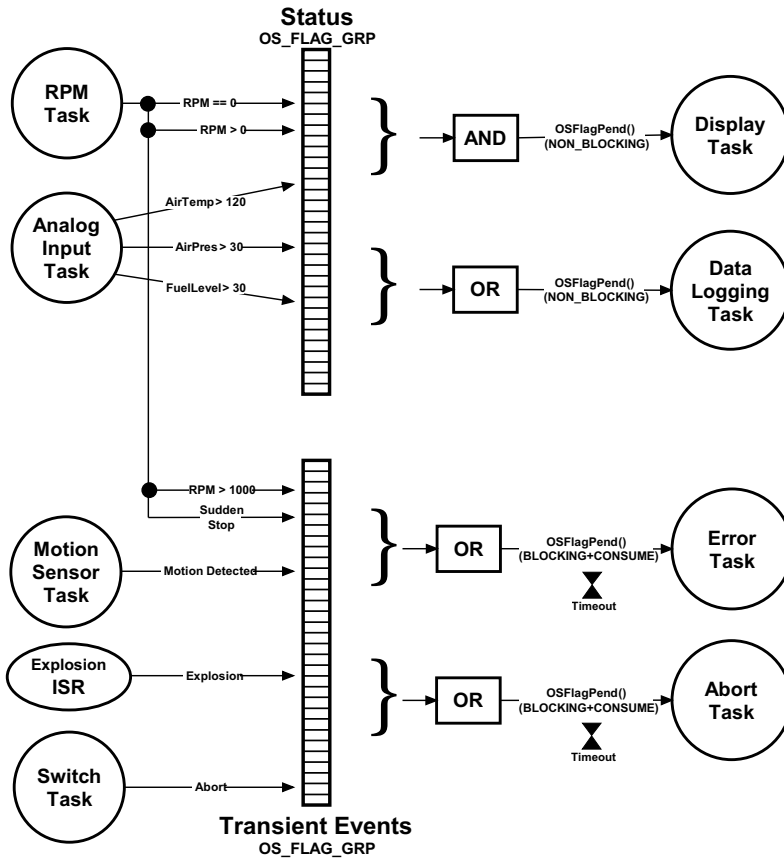

Figure 14-10 Event Flags used for Status and Transient Events

### 14-3-2 EVENT FLAGS INTERNALS

The application programmer can create an unlimited number of event flag groups (limited only by available RAM). Event flag services in  $\mu\text{C}/\text{OS-III}$  start with `OSFlag` and the services available to the application programmer are described in Appendix A, “ $\mu\text{C}/\text{OS-III}$  API Reference Manual” on page 375. Event flag services are enabled at compile time by setting the configuration constant `OS_CFG_FLAG_EN` to 1 in `OS_CFG.H`.

An event flag group is a kernel object as defined by the `OS_FLAG_GRP` data type, which is derived from the structure `os_flag_grp` (see `OS.H`) as shown in Listing 14-10.

The services provided by  $\mu\text{C}/\text{OS-III}$  to manage event flags are implemented in the file `OS_FLAG.C`.  $\mu\text{C}/\text{OS-III}$  licensees have access to the source code.

```
typedef struct os_flag_grp OS_FLAG_GRP; (1)

struct os_flag_grp {
    OS_OBJ_TYPE      Type;           (2)
    CPU_CHAR         *NamePtr;      (3)
    OS_PEND_LIST     PendList;      (4)
    OS_FLAGS         Flags;         (5)
    CPU_TS           TS;            (6)
};
```

Listing 14-10 **OS\_FLAG\_GRP** data type

- L14-10(1) In  $\mu\text{C}/\text{OS-III}$ , all structures are given a data type. In fact, all data types start with “OS\_” and are uppercase. When an event flag group is declared, simply use `OS_FLAG_GRP` as the data type of the variable used to declare the event flag group.
- L14-10(2) The structure starts with a “**Type**” field, which allows it to be recognized by  $\mu\text{C}/\text{OS-III}$  as an event flag group. In other words, other kernel objects will also have a “**Type**” as the first member of the structure. If a function is passed a kernel object,  $\mu\text{C}/\text{OS-III}$  will be able to confirm that it is being passed the proper data type. For example, if passing a message queue (`OS_Q`) to an event flag service (for example `OSFlagPend()`),  $\mu\text{C}/\text{OS-III}$  will be able to recognize that an invalid object was passed, and return an error code accordingly.
- L14-10(3) Each kernel object can be given a name to make them easier to be recognized by debuggers or  $\mu\text{C}/\text{Probe}$ . This member is simply a pointer to an ASCII string, which is assumed to be `NUL` terminated.
- L14-10(4) Because it is possible for multiple tasks to be waiting (or pending) on an event flag group, the event flag group object contains a pend list as described in Chapter 10, “Pend Lists (or Wait Lists)” on page 177.

- 
- L14-10(5) An event flag group contains a series of flags (i.e., bits), and this member contains the current state of these flags. The flags can be implemented using either an 8-, 16- or 32-bit value depending on how the data type `OS_FLAGS` is declared in `OS_TYPE.H`.
- L14-10(6) An event flag group contains a timestamp used to indicate the last time the event flag group was posted to. `μC/OS-III` assumes the presence of a free-running counter that allows users to make time measurements. When the event flag group is posted to, the free-running counter is read and the value is placed in this field, which is returned when `OSFlagPend()` is called. This value allows an application to determine either when the post was performed, or how long it took for your the to obtain control of the CPU from the post. In the latter case, call `OS_TS_GET()` to determine the current timestamp and compute the difference.

Even if the user understands the internals of the `OS_FLAG_GRP` data type, application code should never access any of the fields in this data structure directly. Instead, always use the APIs provided with `μC/OS-III`.

Event flag groups must be created before they can be used by an application as shown in Listing 14-11.

```
OS_FLAG_GRP MyEventFlagGrp;           (1)

void MyCode (void)
{
    OS_ERR err;
    :
    OSFlagCreate(&MyEventFlagGrp,      (2)
                "My Event Flag Group", (3)
                (OS_FLAGS)0,          (4)
                &err);                 (5)
    /* Check 'err' */
    :
}
```

Listing 14-11 **Creating a Event Flag Group**

- L14-11(1) The application must declare a variable of type `OS_FLAG_GRP`. This variable will be referenced by other event flag services.
- L14-11(2) Create an event flag group by calling `OSFlagCreate()` and pass the address to the event flag group allocated in (1).
- L14-11(3) Assign an ASCII name to the event flag group, which can be used by debuggers or  $\mu$ C/Probe to easily identify this event flag group.  $\mu$ C/OS-III stores a pointer to the name so there is no practical limit to its size, except that the ASCII string needs to be `NUL` terminated.
- L14-11(4) Initialize the flags inside the event flag group to zero (0) unless the task and ISRs signal events with bits cleared instead of bits set. If using cleared bits, initialize all the bits to ones (1).
- L14-11(5) `OSFlagCreate()` returns an error code based on the outcome of the call. If all the arguments are valid, `err` will contain `OS_ERR_NONE`.

A task waits for one or more event flag bits either from an ISR or another task by calling `OSFlagPend()` as shown in Listing 14-12 (see Appendix A, “ $\mu$ C/OS-III API Reference Manual” on page 375 for details regarding the arguments).

```

OS_FLAG_GRP  MyEventFlagGrp;

void MyTask (void *p_arg)
{
    OS_ERR  err;
    CPU_TS  ts;
    :
    while (DEF_ON) {
        :
        OSFlagPend(&MyEventFlagGrp,          /* (1) Pointer to event flag group      */
                  (OS_FLAGS)0x0F,          /* Which bits to wait on              */
                  10,                       /* Maximum time to wait               */
                  OS_OPT_PEND_BLOCKING +    /* Option(s)                          */
                  OS_OPT_PEND_FLAG_SET_ANY, /* Timestamp of when posted to        */
                  &ts,                     /* Pointer to Error returned          */
                  &err);                   /* Check "err"                        (2) */
        :
        :
    }
}

```

Listing 14-12 Pending (or waiting) on an Event Flag Group

- L14-12(1) When called, `OSFlagPend()` starts by checking the arguments passed to this function to ensure they have valid values. If the bits the task is waiting for are set (or cleared depending on the option), `OSFlagPend()` returns and indicate which flags satisfied the condition. This is the outcome that the caller expects.

If the event flag group does not contain the flags that the caller is looking for, the calling task might need to wait for the desired flags to be set (or cleared). If specifying `OS_OPT_PEND_NON_BLOCKING` as the option (the task is not to block), `OSFlagPend()` returns immediately to the caller and the returned error code indicates that the bits have not been set (or cleared).

If specifying `OS_OPT_PEND_BLOCKING` as the option, the calling task will be inserted in the list of tasks waiting for the desired event flag bits. The task is not inserted in priority order but simply inserted at the beginning of the list. This is done because whenever bits are set (or cleared), it is necessary to examine all tasks in this list to see if their desired bits have been satisfied.

If further specifying a non-zero timeout, the task will also be inserted in the tick list. A zero value for a timeout indicates that the calling task is willing to wait forever for the desired bits.

The scheduler is then called since the current task is no longer able to run (it is waiting for the desired bits). The scheduler will run the next highest-priority task that is ready to run.

When the event flag group is posted to and the task that called `OSFlagPend()` has its desired bits set or cleared, a task status is examined to determine the reason why `OSFlagPend()` is returning to its caller. The possibilities are:

- 1) The desired bits were set (or cleared)
- 2) The pend was aborted by another task
- 3) The bits were not set (or cleared) within the specified timeout
- 4) The event flag group was deleted

When `OSFlagPend()` returns, the caller is notified of the above outcome through an appropriate error code.

- L14-12(2) If `OSFlagPend()` returns with `err` set to `OS_ERR_NONE`, assume that the desired bits were set (or cleared) and the task can proceed with servicing the ISR or task that created those events. If `err` contains anything else, `OSFlagPend()` either timed out (if the timeout argument was non-zero), the pend was aborted by another task or, the event flag group was deleted by another task. It is always important to examine the returned error code and not assume everything went as planned.

To set (or clear) event flags (either from an ISR or a task), simply call `OSFlagPost()`, as shown in Listing 14-13.

```
OS_FLAG_GRP MyEventFlagGrp;

void MyISR (void)
{
    OS_ERR err;
    :
    OSFlagPost(&MyEventFlagGrp,      (1)
               (OS_FLAGS)0x0C,      (2)
               OS_OPT_POST_FLAG_SET, (3)
               &err);                (4)
    /* Check 'err' */
    :
    :
}
```

Listing 14-13 Posting flags to an Event Flag Group

- L14-13(1) A task posts to the event flag group by calling `OSFlagPost()`. Specify the desired event flag group to post by passing its address. Of course, the event flag group must have been previously created.
- L14-13(2) The next argument specifies which bit(s) the ISR (or task) will be setting or clearing in the event flag group.
- L14-13(3) Specify `OS_OPT_POST_FLAG_SET` or `OS_OPT_POST_FLAG_CLR`.

If specifying `OS_OPT_POST_FLAG_SET`, the bits specified in the second arguments will set the corresponding bits in the event flag group. For example, if `MyEventFlagGrp.Flags` contains `0x03`, the code in Listing 14-13 will change `MyEventFlagGrp.Flags` to `0x0F`.

If specifying `OS_OPT_POST_FLAG_CLR`, the bits specified in the second arguments will clear the corresponding bits in the event flag group. For example, if `MyEventFlagGrp.Flags` contains `0x0F`, the code in Listing 14-13 will change `MyEventFlagGrp.Flags` to `0x03`.

When calling `OSFlagPost()` specify as an option (i.e., `OS_OPT_POST_NO_SCHED`) to not call the scheduler. This means that the post is performed, but the scheduler is not called even if a higher-priority task was waiting for the event flag group. This allows the calling task to perform other post functions (if needed) and make all the posts take effect simultaneously.

L14-13(4) `OSFlagPost()` returns an error code based on the outcome of the call. If the call was successful, `err` will contain `OS_ERR_NONE`. If not, the error code will indicate the reason of the error (see Appendix A, “ $\mu$ C/OS-III API Reference Manual” on page 375 for a list of possible error codes for `OSFlagPost()`).

## 14-4 SYNCHRONIZING MULTIPLE TASKS

Synchronizing the execution of multiple tasks by broadcasting to a semaphore is a commonly used technique. It may be important to have multiple tasks start executing at the same time. Obviously, on a single processor, only one task will actually execute at one time. However, the start of their execution will be synchronized to the same time. This is called a multiple task rendezvous. However, some of the tasks synchronized might not be waiting for the semaphore when the broadcast is performed. It is fairly easy to resolve this problem by combining semaphores and event flags, as shown in Figure 14-11. For this to work properly, the task on the left needs to have a lower priority than the tasks waiting on the semaphore.



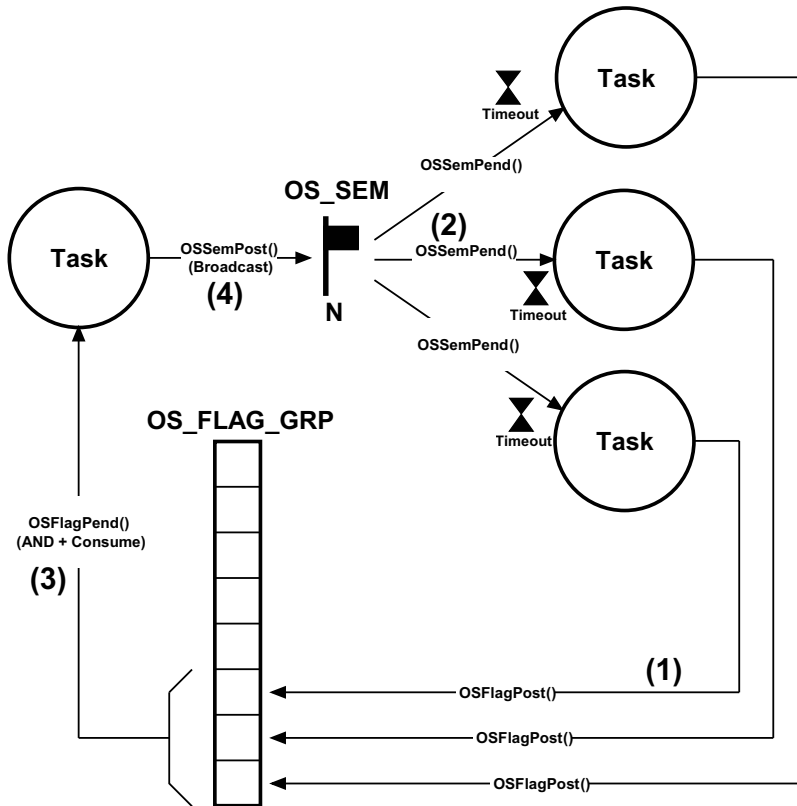

Figure 14-11 Multiple Task Rendezvous

- F14-11(1) Each task that needs to synchronize at the rendezvous needs to set an event flag bit (and specify `OS_OPT_POST_NO_SCHED`).
- F14-11(2) The task needs to wait for the semaphore to be signaled.
- F14-11(3) The task that will be broadcasting must wait for “all” of the event flags corresponding to each task to be set.
- F14-11(4) When all waiting tasks are ready, the task that will synchronize the waiting task issues a broadcast to the semaphore.

## **14-5 SUMMARY**

Three methods are presented to allow an ISR or a task to signal one or more tasks: semaphores, task semaphores, and event flags.

Both semaphores and task semaphores contain a counter allowing them to perform credit tracking and accumulate the occurrence of events. If an ISR or task needs to signal a single task (as opposed to multiple tasks when the event occurs), it makes sense to use a task semaphore since it prevents the user from having to declare an external semaphore object. Also, task semaphore services are slightly faster (in execution time) than semaphores.

Event flags are used when a task needs to synchronize with the occurrence of one or more events. However, event flags cannot perform credit tracking since a single bit (as opposed to a counter) represents each event.

## Message Passing

It is sometimes necessary for a task or an ISR to communicate information to another task. This information transfer is called *inter-task* communication. Information can be communicated between tasks in two ways: through global data, or by sending messages.

As seen in Chapter 13, “Resource Management” on page 209, when using global variables, each task or ISR must ensure that it has exclusive access to variables. If an ISR is involved, the only way to ensure exclusive access to common variables is to disable interrupts. If two tasks share data, each can gain exclusive access to variables either by disabling interrupts, locking the scheduler, using a semaphore, or preferably, using a mutual-exclusion semaphore. Note that a task can only communicate information to an ISR by using global variables. A task is not aware when a global variable is changed by an ISR, unless the ISR signals the task, or the task polls the contents of a variable periodically.

Messages can either be sent to an intermediate object called a *message queue*, or directly to a task since in  $\mu\text{C}/\text{OS-III}$ , each task has its own built-in message queue. Use an external message queue if multiple tasks are to wait for messages. Send a message directly to a task if only one task will process the data received.

When a task waits for a message to arrive, it does not consume CPU time.

## 15-1 MESSAGES

A message consists of a pointer to data, a variable containing the size of the data being pointed to, and a timestamp indicating when the message was sent. The pointer can point to a data area or even a function. Obviously, the sender and the receiver must agree as to the contents and the meaning of the message. In other words, the receiver of the message will know the meaning of the message received to be able to process it. For example, an Ethernet controller receives a packet and sends a pointer to this packet to a task that knows how to handle the packet.

The message contents must always remain in scope since the data is actually sent by reference instead of by value. In other words, data sent is not copied. Consider using dynamically allocated memory as described in Chapter 17, “Memory Management” on page 323. Alternatively, pass pointers to a global variable, a global data structure, a global array, or a function, etc.

## 15-2 MESSAGE QUEUES

A message queue is a kernel object allocated by the application. In fact, you can allocate any number of message queues. The only limit is the amount of RAM available.

There are a number of operations that the user can perform on message queues, summarized in Figure 15-1. However, an ISR can only call `OSQPost()`. A message queue must be created before sending messages through it.

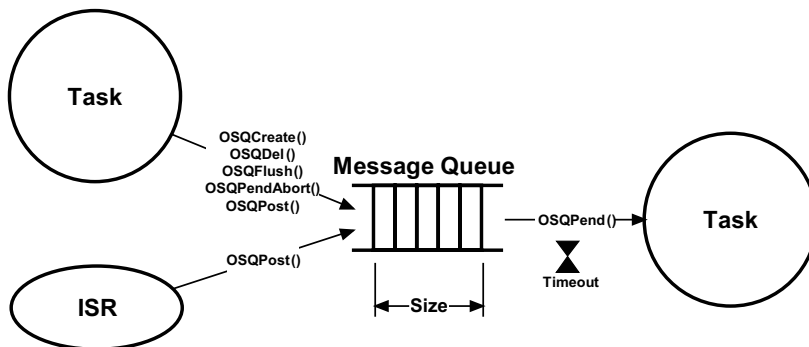

Figure 15-1 Operations on message queue

Message queues are drawn as a first-in, first-out pipe (FIFO). However, with  $\mu\text{C}/\text{OS-III}$ , it is possible to post messages in last-in, first-out order (LIFO). The LIFO mechanism is useful when a task or an ISR must send an “urgent” message to a task. In this case, the message bypasses all other messages already in the message queue. The size of the message queue is configurable at run time.

The small hourglass close to the receiving task indicates that the task has an option to specify a timeout. This timeout indicates that the task is willing to wait for a message to be sent to the message queue within a certain amount of time. If the message is not sent within that time,  $\mu\text{C}/\text{OS-III}$  resumes the task and returns an error code indicating that the task was made ready to run because of a timeout, and not because the message was received. It is possible to specify an infinite timeout and indicate that the task is willing to wait forever for the message to arrive.

The message queue also contains a list of tasks waiting for messages to be sent to the message queue. Multiple tasks can wait on a message queue as shown in Figure 15-2. When a message is sent to the message queue, the highest priority task waiting on the message queue receives the message. Optionally, the sender can *broadcast* a message to all tasks waiting on the message queue. In this case, if any of the tasks receiving the message from the broadcast has a higher priority than the task sending the message (or interrupted task, if the message is sent by an ISR),  $\mu\text{C}/\text{OS-III}$  will run the highest-priority task that is waiting. Notice that not all tasks must specify a timeout; some tasks may want to wait forever.

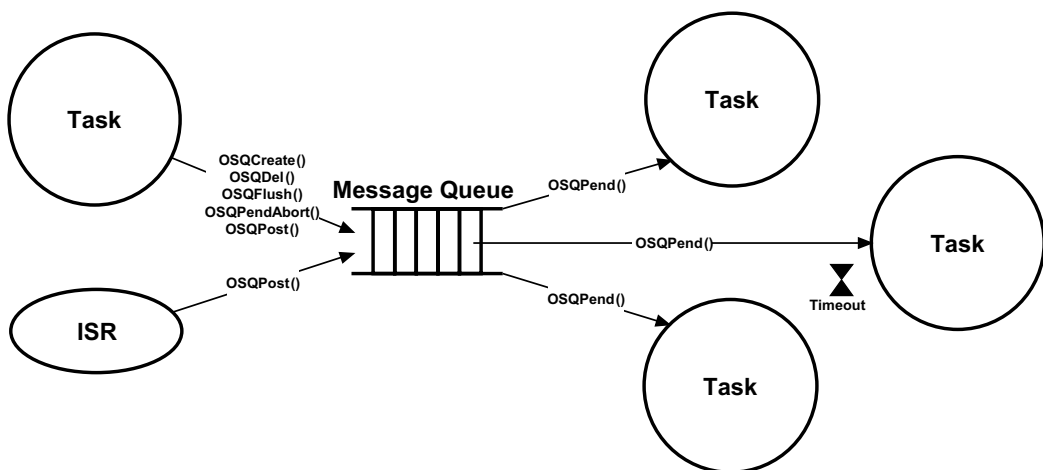

Figure 15-2 Multiple tasks waiting on a message queue

### 15-3 TASK MESSAGE QUEUE

It is fairly rare to find applications where multiple tasks wait on a single message queue. Because of this, a message queue is built into each task and the user can send messages directly to a task without going through an external message queue object. This feature not only simplifies the code but, is also more efficient than using a separate message queue object. The message queue that is built into each task is shown in Figure 15-3.

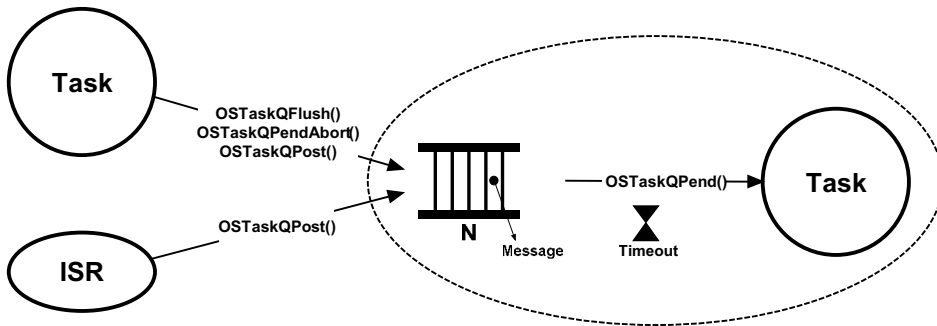

Figure 15-3 Task message queue

Task message queue services in  $\mu$ C/OS-III start with the `OSTaskQ???` ( ) prefix, and services available to the application programmer are described in Appendix A, “ $\mu$ C/OS-III API Reference Manual” on page 375. Setting `OS_CFG_TASK_EN` in `OS_CFG.H` enables task message queue services. The code for task message queue management is found in `OS_TASK.C`.

Use this feature if the code knows which task to send the message(s) to. For example, if receiving an interrupt from an Ethernet controller, send the address of the received packet to the task that will be responsible for processing the received packet.

### 15-4 BILATERAL RENDEZVOUS

Two tasks can synchronize their activities by using two message queues, as shown in Figure 15-4. This is called a *bilateral rendezvous* and works the same as with semaphores except that both tasks may send messages to each other. A bilateral rendezvous cannot be performed between a task and an ISR since an ISR cannot wait on a message queue.

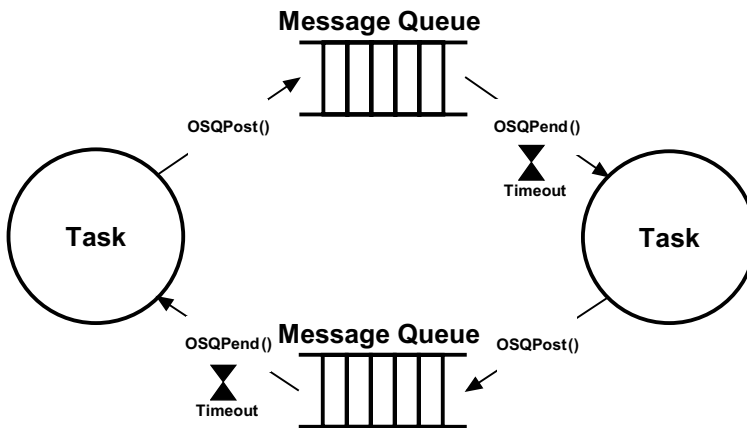

Figure 15-4 **Bilateral Rendezvous**

In a bilateral rendezvous, each message queue holds a maximum of one message. Both message queues are initially created empty. When the task on the left reaches the rendezvous point, it sends a message to the top message queue and waits for a message to arrive on the bottom message queue. Similarly, when the task on the right reaches its rendezvous point, it sends a message to the message queue on the bottom and waits for a message to arrive on the top message queue.

Figure 15-5 shows how to use task-message queues to perform a bilateral rendezvous.

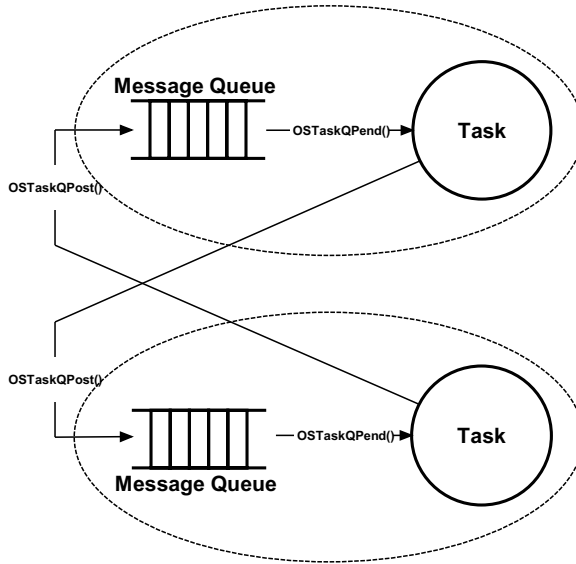

Figure 15-5 **Figure Bilateral Rendezvous with task message queues**

## 15-5 FLOW CONTROL

Task-to-task communication often involves data transfer from one task to another. One task produces data while the other *consumes* it. However, data processing takes time and consumers might not consume data as fast as it is produced. In other words, it is possible for the producer to overflow the message queue if a higher-priority task preempts the consumer. One way to solve this problem is to add flow control in the process as shown in Figure 15-6.

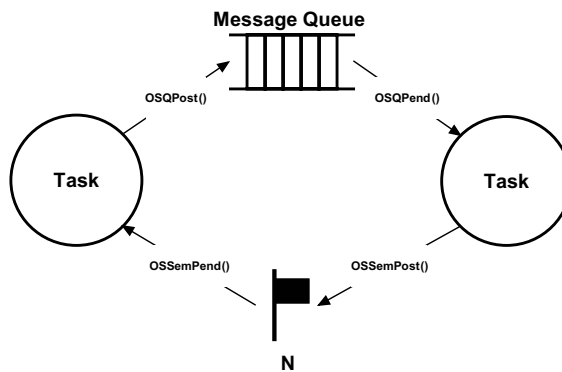

Figure 15-6 **Producer and consumer tasks with flow control**



Here, a counting semaphore is used, initialized with the number of allowable messages that can be sent by the consumer. If the consumer cannot queue more than 10 messages, the counting semaphore contains a count of 10.

As shown in the pseudo code of Listing 15-1, the producer must wait on the semaphore before it is allowed to send a message. The consumer waits for messages and, when processed, signals the semaphore.

```
Producer Task:
Pend on Semaphore;
Send message to message queue;

Consumer Task:
Wait for message from message queue;
Signal the semaphore;
```

Listing 15-1 **Producer and consumer flow control**

Combining the task message queue and task semaphores (see Chapter 14, “Synchronization” on page 251), it is easy to implement flow control as shown in Figure 15-7. In this case, however, `OSTaskSemSet()` must be called immediately after creating the task to set the value of the task semaphore to the same value as the maximum number of allowable messages in the task message queue.

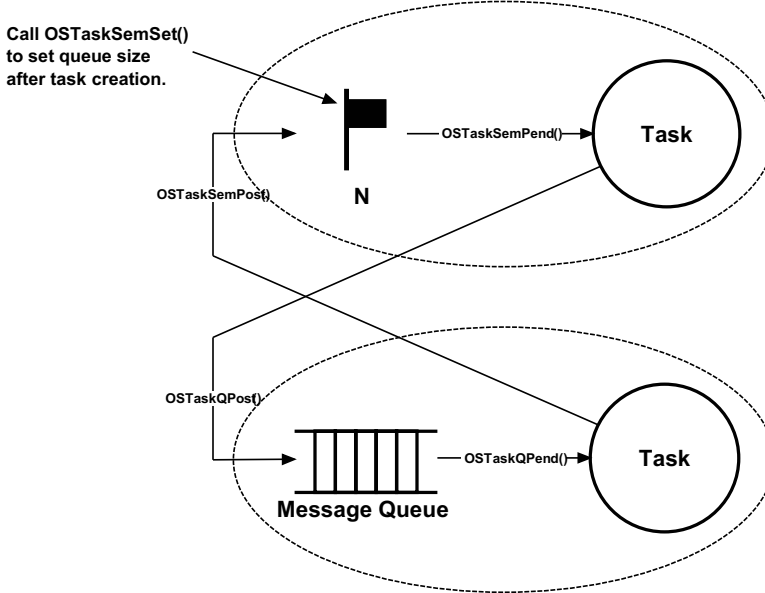

Figure 15-7 Flow control with task semaphore and task message queue

## 15-6 KEEPING THE DATA IN SCOPE

The messages sent typically point to data structures, variables, arrays, tables, etc. However, it is important to realize that the data must remain static until the receiver of the data completes its processing of the data. Once sent, the sender must not touch the sent data. This seems obvious, however it is easy to forget.

One possibility is to use the fixed-size memory partition manager provided with  $\mu\text{C}/\text{OS-III}$  (see Chapter 17, “Memory Management” on page 323) to dynamically allocate and free memory blocks used to pass the data. Figure 15-8 shows an example. For sake of illustration, assume that a device is sending data bytes to the UART in packets using a protocol. In this case, the first byte of a packet is unique and the end-of-packet byte is also unique.

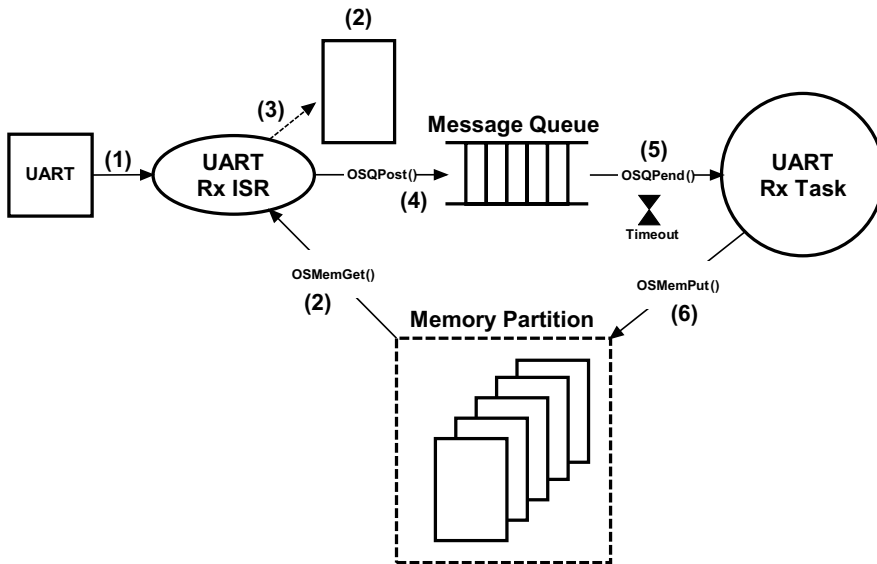

Figure 15-8 Using memory partitions for message contents

- F15-8(1) Here, a UART generates an interrupt when characters are received.
- F15-8(2) The pseudo-code in Listing 15-2 shows what the UART ISR code might look like. There are a lot of details omitted for sake of simplicity. The ISR reads the byte received from the UART and sees if it corresponds to a start of packet. If it is, a buffer is obtained from the memory partition.
- F15-8(3) The received byte is then placed in the buffer.
- F15-8(4) If the data received is an end-of-packet byte, simply post the address of the buffer to the message queue so that the task can process the received packet.
- F15-8(5) If the message sent makes the UART task the highest priority task,  $\mu\text{C}/\text{OS-III}$  will switch to that task at the end of the ISR instead of returning to the interrupted task. The task retrieves the packet from the message queue. Note that the `OSQPend()` call also returns the number of bytes in the packet and a time stamp indicating when the message was sent.
- F15-8(6) When the task is finished processing the packet, the buffer is returned to the memory partition it came from by calling `OSMemPut()`.

```
void UART_ISR (void)
{
    OS_ERR err;

    RxData = Read byte from UART;
    if (RxData == Start of Packet) {
        RxDataPtr = OSMemGet(&UART_MemPool,
                            &err);
        RxDataCtr = 0;
    } else {
        RxDataCtr++;
    }
    if (RxData == End of Packet byte) {
        OSQPost((OS_Q *)&UART_Q,
                (void *)RxDataPtr,
                (OS_MSG_SIZE)RxDataCtr,
                (OS_OPT )OS_OPT_POST_FIFO,
                (OS_ERR *)&err);
        RxDataPtr = NULL;
        RxDataCtr = 0;
    } else; {
        *RxDataPtr++ = RxData;
    }
}
```

Listing 15-2 UART ISR Pseudo-code

## 15-7 USING MESSAGE QUEUES

Table 15-1 shows a summary of message-queue services available from  $\mu\text{C}/\text{OS-III}$ . Refer to Appendix A, “ $\mu\text{C}/\text{OS-III}$  API Reference Manual” on page 375 for a full description on their use.

| Function Name  | Operation                               |
|----------------|---|
| OSQCreate()    | Create a message queue.                 |
| OSQDel()       | Delete a message queue.                 |
| OSQFlush()     | Empty the message queue.                |
| OSQPend()      | Wait for a message.                     |
| OSQPendAbort() | Abort waiting for a message.            |
| OSQPost()      | Send a message through a message queue. |

Table 15-1 **Message queue API summary**

Table 15-2 is a summary of task message queue services available from  $\mu\text{C}/\text{OS-III}$ . Refer to Appendix A, “ $\mu\text{C}/\text{OS-III}$  API Reference Manual” on page 375, for a full description on how to their use.

| Function Name      | Operation                     |
|--------------------|-------------------------------|
| OSTaskQPend()      | Wait for a message.           |
| OSTaskQPendAbort() | Abort the wait for a message. |
| OSTaskQPost()      | Send a message to a task.     |
| OSTaskQFlush()     | Empty the message queue.      |

Table 15-2 **Task message queue API summary**

Figure 15-9 shows an example of using a message queue when determining the speed of a rotating wheel.

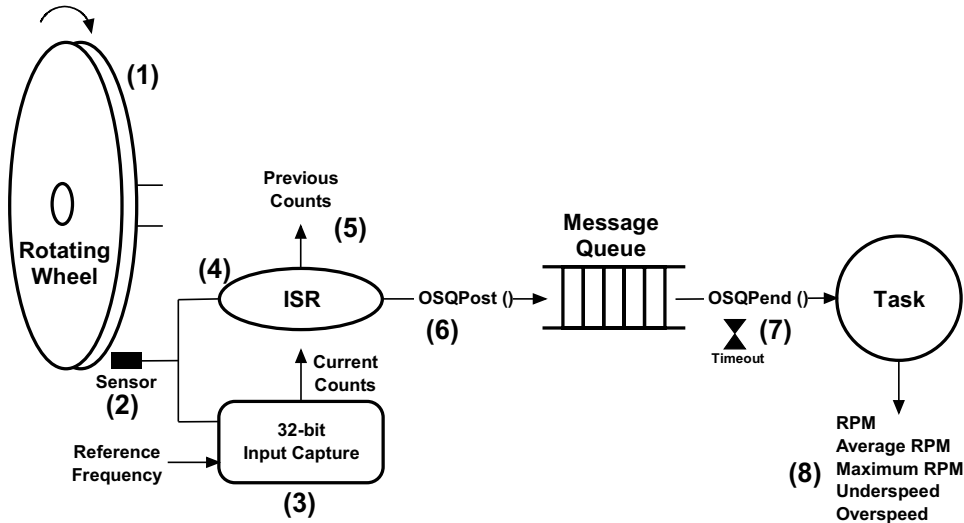

Figure 15-9 Measuring RPM

- F15-9(1) The goal is to measure the RPM of a rotating wheel.
- F15-9(2) A sensor is used to detect the passage of a hole in the wheel. In fact, to receive additional resolution, the wheel could contain multiple holes that are equally spaced.
- F15-9(3) A 32-bit input capture register is used to capture the value of a free-running counter when the hole is detected.
- F15-9(4) An interrupt is generated when the hole is detected. The ISR reads the current count of the input capture register and subtracts the value of the previous capture to receive the time it took for one rotation (assuming only a single hole).

```
Delta Counts = Current Counts - Previous Counts;
Previous Counts = Current Counts;
```

---

F15-9(5) The delta counts are sent to a message queue. Since a message is actually a pointer, if the pointer is 32-bits wide on the processor in use, simply cast the 32-bit delta counts to a pointer and send this through the message queue. A safer and more portable approach is to dynamically allocate storage to hold the delta counts using a memory block from  $\mu\text{C}/\text{OS-III}$ 's memory management services (see Chapter 17, "Memory Management" on page 323) and send the address of the allocated memory block.

F15-9(6) When the message is sent, the RPM measurement task wakes up and computes the RPM as follows:

```
RPM = 60 * Reference Frequency / Delta Counts;
```

The user may specify a timeout on the pend call and the task will wake up if a message is not sent within the timeout period. This allows the user to easily detect that the wheel is not rotating and therefore, the RPM is 0.

F15-9(7) Along with computing RPM, the task can also compute average RPM, maximum RPM, and whether the speed is above or below thresholds, etc.

A few interesting things are worth noting about the above example. First, the ISR is very short; read the input capture and post the delta counts to the task to accomplish the time-consuming math. Second, with the timeout on the pend, it is easy to detect that the wheel is stopped. Finally, the task can perform additional calculations and can further detect such errors as the wheel spinning too fast or too slow. In fact, the task can notify other tasks about these errors, if needed.

Listing 15-3 shows how to implement the RPM measurement example using  $\mu\text{C}/\text{OS-III}$ 's message queue services. Some of the code is pseudo-code, while the calls to  $\mu\text{C}/\text{OS-III}$  services are actual calls with their appropriate arguments.

```
OS_Q      RPM_Q;                                (1)
CPU_INT32U DeltaCounts;
CPU_INT32U CurrentCounts;
CPU_INT32U PreviousCounts;

void main (void)
{
    OS_ERR err ;
    :
    OSInit(&err) ;                               (2)
    :
    OSQCreate((OS_Q      *)&RPM_Q,
              (CPU_CHAR *)"My Queue",
              (OS_MSG_QTY)10,
              (OS_ERR   *)&err);
    :
    OSStart(&err);
}

void RPM_ISR (void)                             (3)
{
    OS_ERR err;

    Clear the interrupt from the sensor;
    CurrentCounts = Read the input capture;
    DeltaCounts   = CurrentCounts - PreviousCounts;
    PreviousCounts = CurrentCounts;
    OSQPost((OS_Q      *)&RPM_Q,                (4)
            (void      *)DeltaCounts,
            (OS_MSG_SIZE)sizeof(void *),
            (OS_OPT    )OS_OPT_POST_FIFO,
            (OS_ERR    *)&err);
}
```



```

void RPM_Task (void *p_arg)
{
    CPU_INT32U  delta;
    OS_ERR      err;
    OS_MSG_SIZE size;
    CPU_TS      ts;

    DeltaCounts = 0;
    PreviousCounts = 0;
    CurrentCounts = 0;
    while (DEF_ON) {
        delta = (CPU_INT32U)OSQPend((OS_Q      *)&RPM_Q,          (5)
                                   (OS_TICK    )OS_CFG_TICK_RATE * 10,
                                   (OS_OPT     )OS_OPT_PEND_BLOCKING,
                                   (OS_MSG_SIZE *)&size,
                                   (CPU_TS     *)&ts,
                                   (OS_ERR     *)&err);

        if (err == OS_ERR_TIMEOUT) {                                (6)
            RPM = 0;
        } else {
            if (delta > 0u) {                                       (7)
                RPM = 60 * Reference Frequency / delta;
            }
        }
        Compute average RPM;                                       (8)
        Detect maximum RPM;
        Check for overspeed;
        Check for underspeed;
        :
        :
    }
}

```

Listing 15-3 Pseudo-code of RPM measurement

- L15-3(1) Variables are declared. Notice that it is necessary to allocate storage for the message queue itself.
- L15-3(2) Call `OSInit()` and create the message queue before it is used. The best place to do this is in startup code.

L15-3(3) The RPM ISR clears the sensor interrupt and reads the value of the 32-bit input capture. Note that it is possible to read RPM if there is only a 16-bit input capture. The problem with a 16-bit input capture is that it is easy for it to overflow, especially at low RPMs.

The RPM ISR also computes delta counts directly in the ISR. It is just as easy to post the current counts and let the task compute the delta. However, the subtraction is a fast operation and does not significantly increase ISR processing time.

L15-3(4) Send the delta counts to the RPM task, responsible for computing the RPM and perform additional computations. Note that the message gets lost if the queue is full when the user attempts to post. This happens if data is generated faster than it is processed. Unfortunately, it is not possible to implement flow control in the example because it is dealing with an ISR.

L15-3(5) The RPM task starts by waiting for a message from the RPM ISR by pending on the message queue. The third argument specifies the timeout. In this case, ten seconds worth of timeout is specified. However, the value chosen depends on the requirements of an application.

Also notice that the `ts` variable contains the timestamp of when the post was completed. Determine the time it took for the task to respond to the message received by calling `OS_TS_GET()`, and subtract the value of `ts`:

```
response_time = OS_TS_GET() - ts;
```

L15-3(6) If a timeout occurs, assume the wheel is no longer spinning.

L15-3(7) The RPM is computed from the delta counts received, and from the reference frequency of the free-running counter.

L15-3(8) Additional computations are performed as needed. In fact, messages can be sent to different tasks in case error conditions are detected. The messages would be processed by the other tasks. For example, if the wheel spins too fast, another task can initiate a shutdown on the device that is controlling the wheel speed.

In Listing 15-4, `OSQPost()` and `OSQPend()` are replaced with `OSTaskQPost()` and `OSTaskQPend()` for the RPM measurement example. Notice that the code is slightly simpler to use and does not require creating a separate message queue object. However, when creating the RPM task, it is important to specify the size of the message queue used by the task and compile the application code with `OS_CFG_TASK_Q_EN` set to 1. The differences between using message queues and the task's message queue will be explained.

```
OS_TCB      RPM_TCB;                                (1)
OS_STK      RPM_Stk[1000];
CPU_INT32U  DeltaCounts ;
CPU_INT32U  CurrentCounts ;
CPU_INT32U  PreviousCounts ;

void main (void)
{
    OS_ERR  err ;
    :
    OSInit(&err) ;
    :
    void OSTaskCreate ((OS_TCB      *)&RPM_TCB,                (2)
                      (CPU_CHAR    *)"RPM Task",
                      (OS_TASK_PTR  )RPM_Task,
                      (void         *)0,
                      (OS_PRIO      )10,
                      (CPU_STK      *)&RPM_Stk[0],
                      (CPU_STK_SIZE )100,
                      (CPU_STK_SIZE )1000,
                      (OS_MSG_QTY   )10,
                      (OS_TICK      )0,
                      (void         *)0,
                      (OS_OPT       )(OS_OPT_TASK_STK_CHK + OS_OPT_TASK_STK_CLR),
                      (OS_ERR       *)&err);
    :
    OSStart(&err);
}
```

```
void RPM_ISR (void)
{
    OS_ERR err;

    Clear the interrupting from the sensor;
    CurrentCounts = Read the input capture;
    DeltaCounts = CurrentCounts - PreviousCounts;
    PreviousCounts = CurrentCounts;
    OSTaskQPost((OS_TCB *)&RPM_TCB, (3)
                (void *)DeltaCounts,
                (OS_MSG_SIZE)sizeof(DeltaCounts),
                (OS_OPT)OS_OPT_POST_FIFO,
                (OS_ERR *)&err);
}

void RPM_Task (void *p_arg)
{
    CPU_INT32U delta;
    OS_ERR err;
    OS_MSG_SIZE size;
    CPU_TS ts;

    DeltaCounts = 0;
    PreviousCounts = 0;
    CurrentCounts = 0;
    while (DEF_ON) {
        delta = (CPU_INT32U)OSTaskQPend((OS_TICK)OS_CFG_TICK_RATE * 10, (4)
                                       (OS_OPT)OS_OPT_PEND_BLOCKING,
                                       (OS_MSG_SIZE *)&size,
                                       (CPU_TS *)&ts,
                                       (OS_ERR *)&err);

        if (err == OS_ERR_TIMEOUT) {
            RPM = 0;
        } else {
            if (delta > 0u) {
                RPM = 60 * ReferenceFrequency / delta;
            }
        }
        Compute average RPM;
        Detect maximum RPM;
        Check for overspeed;
        Check for underspeed;
        :
        :
    }
}
```

Listing 15-4 Pseudo-code of RPM measurement

- L15-4(1) Instead of declaring a message queue, it is important to know the `OS_TCB` of the task that will be receiving messages.
- L15-4(2) The RPM task is created and a queue size of 10 entries is specified. Of course, hard-coded values should not be specified in a real application, but instead, use `#defines`. Fixed numbers are used here for sake of illustration.
- L15-4(3) Instead of posting to a message queue, the ISR posts the message directly to the task, specifying the address of the `OS_TCB` of the task. This is known since the `OS_TCB` is allocated when creating the task.
- L15-4(4) The RPM task starts by waiting for a message from the RPM ISR by calling `OSTaskQPend()`. This is an inherent call so it is not necessary to specify the address of the `OS_TCB` to pend on as the current task is assumed. The second argument specifies the timeout. Here, ten seconds worth of timeout is specified, which corresponds to 6 RPM.

## 15-8 CLIENTS AND SERVERS

Another interesting use of message queues is shown in Figure 15-10. Here, a task (the server) is used to monitor error conditions that are sent to it by other tasks or ISRs (clients). For example, a client detects whether the RPM of the rotating wheel has been exceeded, another client detects whether an over-temperature exists, and yet another client detects that a user pressed a shutdown button. When the clients detect error conditions, they send a message through the message queue. The message sent indicates the error detected, which threshold was exceeded, the error code that is associated with error conditions, or even suggests the address of a function that will handle the error, and more.

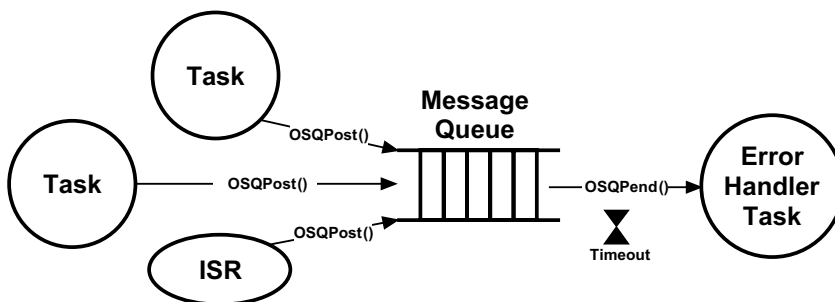

Figure 15-10 Clients and Servers

## 15-9 MESSAGE QUEUES INTERNALS

As previously described, a message consists of a pointer to actual data, a variable indicating the size of the data being pointed to and a timestamp indicating when the message was actually sent. When sent, a message is placed in a data structure of type `OS_MSG`, shown in Figure 15-11.

The sender and receiver are unaware of this data structure since everything is hidden through the APIs provided by  $\mu$ C/OS-III.

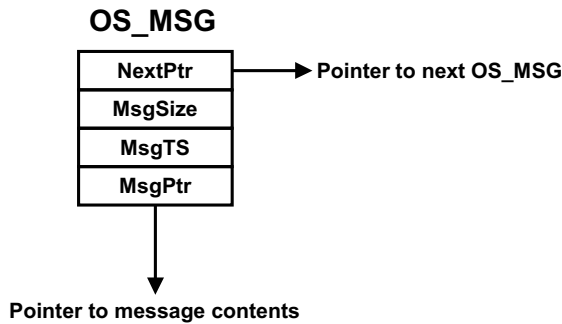

Figure 15-11 `OS_MSG` structure

$\mu$ C/OS-III maintains a pool of free `OS_MSG`s. The total number of available messages in the pool is determined by the value of `OS_CFG_MSG_POOL_SIZE` found in `OS_CFG_APP.H`. When  $\mu$ C/OS-III is initialized, `OS_MSG`s are linked in a single linked list as shown in Figure 15-12. Notice that the free list is maintained by a data structure of type `OS_MSG_POOL`, which contains three fields: `.NextPtr`, which points to the free list; `.NbrFree`, which contains the number of free `OS_MSG`s in the pool; and finally `.NbrUsed`, which contains the number of `OS_MSG`s allocated to application.

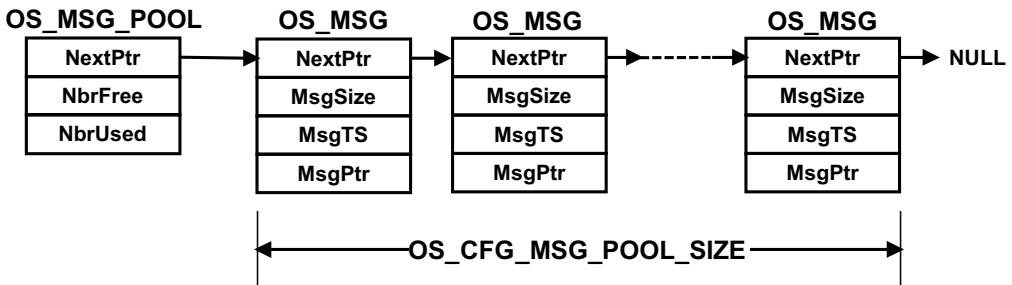

Figure 15-12 Pool of free `OS_MSG`s

Messages are queued using a data structure of type `OS_MSG_Q`, as shown in Figure 15-13.

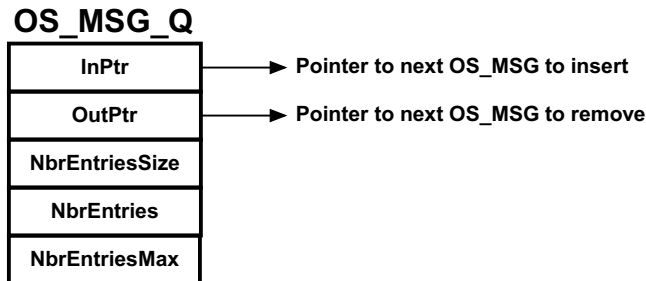

Figure 15-13 **OS\_MSG\_Q structure**

- `.InPtr`                    This field contains a pointer to where the next `OS_MSG` will be inserted in the queue. In fact, the `OS_MSG` will be inserted “after” the `OS_MSG` pointed to.
  
- `.OutPtr`                    This field contains a pointer to where the next `OS_MSG` will be extracted.
  
- `.NbrEntriesSize`            This field contains the maximum number of `OS_MSGs` that the queue will hold. If an application attempts to send a message and the `.NbrEntries` matches this value, the queue is considered to be full and the `OS_MSG` will not be inserted.
  
- `.NbrEntries`                This field contains the current number of `OS_MSGs` in the queue.
  
- `.NbrEntriesMax`            This field contains the highest number of `OS_MSGs` existing in the queue at any given time.

A number of internal functions are used by  $\mu\text{C}/\text{OS-III}$  to manipulate the free list and messages. Specifically, `OS_MsgQPut()` inserts an `OS_MSG` in an `OS_MSG_Q`, `OS_MsgQGet()` extracts an `OS_MSG` from an `OS_MSG_Q`, and `OS_MsgQFreeAll()` returns all `OS_MSGs` in an `OS_MSG_Q` to the pool of free `OS_MSGs`. There are other `OS_MsgQ??()` functions in `OS_MSG.C` that are used during initialization.

Figure 15-14 shows an example of an `OS_MSG_Q` when four `OS_MSGs` are inserted.

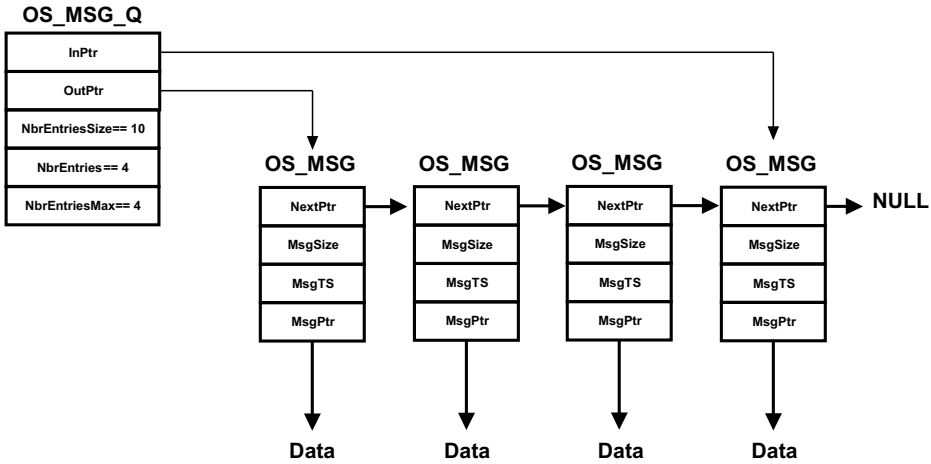

Figure 15-14 `OS_MSG_Q` with four `OS_MSGs`

`OS_MSG_Qs` are used inside two additional data structures: `OS_Q` and `OS_TCB`. Recall that an `OS_Q` is declared when creating a message queue object. An `OS_TCB` is a task control block and, as previously mentioned, each `OS_TCB` can have its own message queue when the configuration constant `OS_CFG_TASK_Q_EN` is set to 1 in `OS_CFG.H`. Figure 15-15 shows the contents of an `OS_Q` and partial contents of an `OS_TCB` containing an `OS_MSG_Q`. The `OS_MSG_Q` data structure is shown as an “exploded view” to emphasize the structure within the structure.

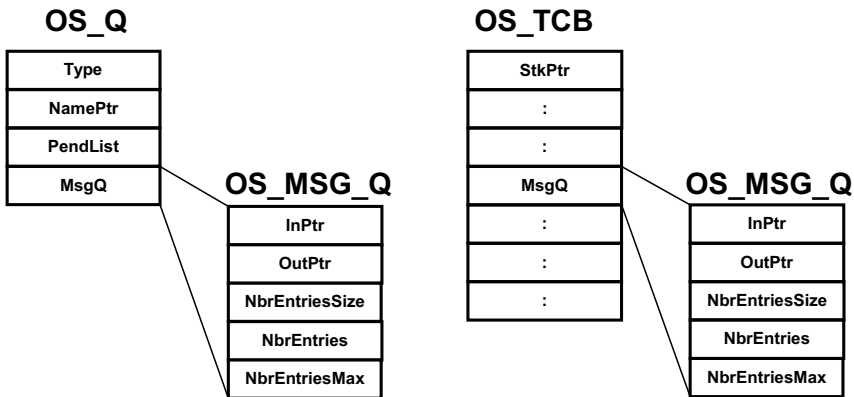

Figure 15-15 `OS_Q` and `OS_TCB` each contain an `OS_MSG_Q`



## 15-10 SUMMARY

Message queues are useful when a task or an ISR is to send data to another task. The data sent must remain in scope as it is actually sent by reference instead of by value. In other words, the data sent is not copied.

The task waiting for the data will not consume CPU time while waiting for a message to be sent to it.

If it is known which task is responsible for servicing messages sent by producers, use task message queue (i.e., `OSTaskQ???( )`) services since they are simple and fast. Task message queue services are enabled when `OS_CFG_TASK_Q_EN` is set to 1 in `OS_CFG.H`.

If multiple tasks must wait for messages from the same message queue, allocate an `OS_Q` and have the tasks wait for messages to be sent to the queue. Alternatively, broadcast special messages to all tasks waiting on a message queue. Regular message queue services are enabled when `OS_CFG_Q_EN` is set to 1 in `OS_CFG.H`.

Messages are sent using an `OS_MSG` data structure obtained by  $\mu\text{C}/\text{OS-III}$  from a pool. Set the maximum number of messages that can be sent to a message queue, or as many messages as are available in the pool.



## Pending On Multiple Objects

In Chapter 10, “Pend Lists (or Wait Lists)” on page 177 we saw how multiple tasks can pend (or wait) on a single kernel object such as a semaphore, mutual exclusion semaphore, event flag group, or message queue. In this chapter, we will see how tasks can pend on multiple objects. However,  $\mu$ C/OS-III only allows for pend on multiple semaphores and/or message queues. In other words, it is not possible to pend on multiple event flag groups or mutual exclusion semaphores.

As shown in Figure 16-1, a task can pend on any number of semaphores or message queues at the same time. The first semaphore or message queue posted will make the task ready to run and compete for CPU time with other tasks in the ready list. As shown, a task pends on multiple objects by calling `OSPendMulti()` and specifies an optional timeout value. The timeout applies to all of the objects. If none of the objects are posted within the specified timeout, the task resumes with an error code indicating that the pend timed out.

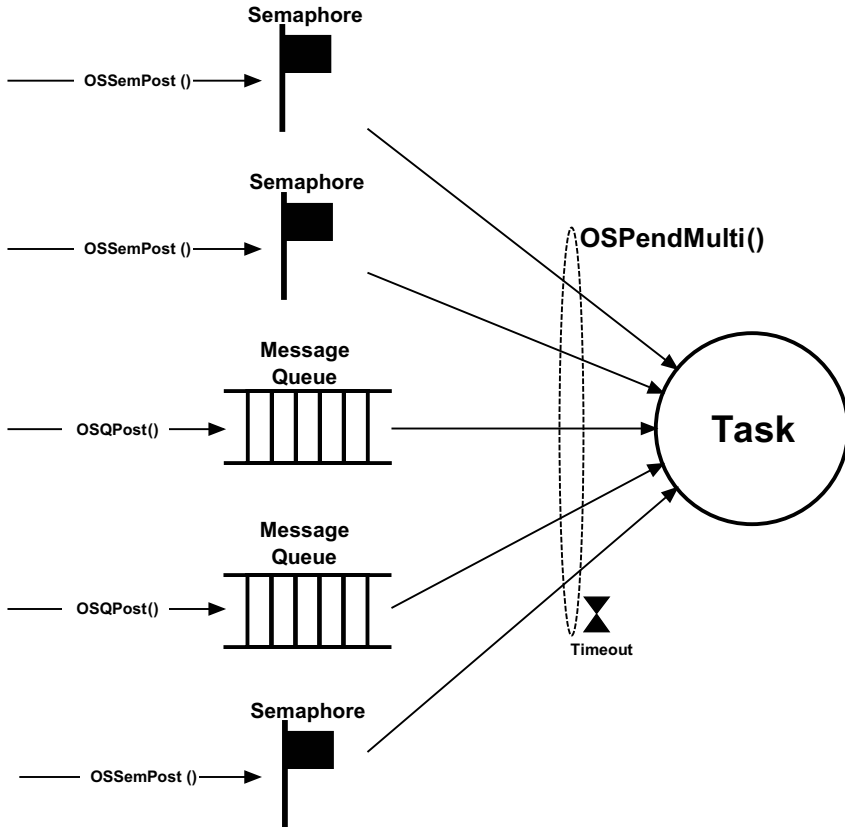

Figure 16-1 Task pending on multiple objects

Listing 16-1 shows the function prototype of `OSPendMulti()` and Figure 16-2 exhibits an array of `OS_PEND_DATA` elements.

```

OS_OBJ_QTY  OSPendMulti (OS_PEND_DATA *p_pend_data_tbl,           (1)
                      OS_OBJ_QTY   tbl_size,                     (2)
                      OS_TICK       timeout,                     (3)
                      OS_OPT        opt,                         (4)
                      OS_ERR        *p_err);                     (5)
    
```

Listing 16-1 `OSPendMulti()` prototype

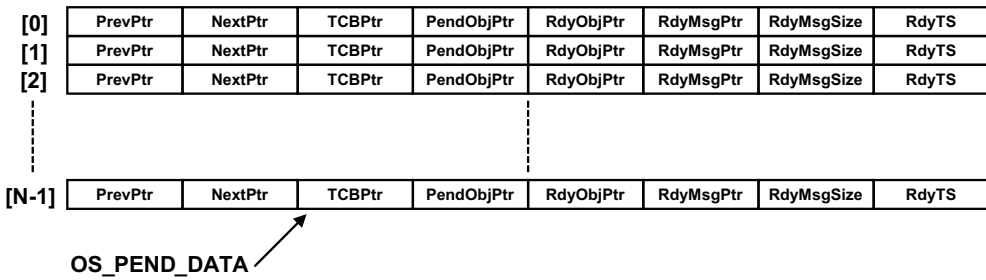

Figure 16-2 Array of `OS_PEND_DATA`

L16-1(1) `OSPendMulti()` is passed an array of `OS_PEND_DATA` elements. The caller must instantiate an array of `OS_PEND_DATA`. The size of the array depends on the total number of kernel objects that the task wants to pend on. For example, if the task wants to pend on three semaphores and two message queues then the array contains five `OS_PEND_DATA` elements as shown below:

```

OS_PEND_DATA  my_pend_multi_tbl[5];
    
```

The calling task needs to initialize the `.PendObjPtr` of each element of the array to point to each of the objects to be pended on. For example:

```
OS_SEM MySem1;
OS_SEM MySem2;
OS_SEM MySem3;
OS_Q MyQ1;
OS_Q MyQ2;

void MyTask (void)
{
    OS_ERR err;
    OS_PEND_DATA my_pend_multi_tbl[5];
    :
    while (DEF_ON) {
        :
        my_pend_multi_tbl[0].PendObjPtr = (OS_PEND_OBJ)&MySem1;      (6)
        my_pend_multi_tbl[1].PendObjPtr = (OS_PEND_OBJ)&MySem2;
        my_pend_multi_tbl[2].PendObjPtr = (OS_PEND_OBJ)&MySem3;
        my_pend_multi_tbl[3].PendObjPtr = (OS_PEND_OBJ)&MyQ1;
        my_pend_multi_tbl[4].PendObjPtr = (OS_PEND_OBJ)&MyQ2;
        OSPendMulti((OS_PEND_DATA *)&my_pend_multi_tbl[0],
                    (OS_OBJ_QTY )5,
                    (OS_TICK )0,
                    (OS_OPT )OS_OPT_PEND_BLOCKING,
                    (OS_ERR *)&err);
        /* Check 'err' */
        :
    }
}
```

L16-1(2) This argument specifies the size of the `OS_PEND_DATA` table. In the above example, this is 5.

L16-1(3) Specify whether or not to timeout in case none of the objects are posted within a certain amount of time. A non-zero value indicates the number of ticks to timeout. Specifying zero indicates the task will wait forever for any of the objects to be posted.

L16-1(4) The “opt” argument specifies whether to wait for objects to be posted (set opt to `OS_OPT_PEND_BLOCKING`) or, not block if none of the objects have already been posted (set opt to `OS_OPT_PEND_NON_BLOCKING`).

F16-2(1) As with most  $\mu$ C/OS-III function calls, specify the address of a variable that will receive an error code based on the outcome of the function call. See Appendix A, “ $\mu$ C/OS-III API Reference Manual” on page 375 for a list of possible error codes. As always, it is highly recommended to examine the error return code.

F16-2(2) Note that all objects are cast to `OS_PEND_OBJ` data types.

When called, `OSPendMulti()` first starts by validating that all of the objects specified in the `OS_PEND_DATA` table are either an `OS_SEM` or an `OS_Q`. If not, an error code is returned.

Next, `OSPendMulti()` goes through the `OS_PEND_DATA` table to see if any of the objects have already posted. If so, `OSPendMulti()` fills the following fields in the table: `.RdyObjPtr`, `.RdyMsgPtr`, `.RdyMsgSize` and `.RdyTS`.

`.RdyObjPtr` is a pointer to the object if the object has been posted. For example, if the first object in the table is a semaphore and the semaphore has been posted to, `my_pend_multi_tbl[0].RdyObjPtr` is set to `my_pend_multi_tbl[0].PendObjPtr`.

`.RdyMsgPtr` is a pointer to a message if the object in the table at this entry is a message queue and a message was received from the message queue.

`.RdyMsgSize` is the size of the message received if the object in the table at this entry is a message queue and a message was received from the message queue.

`.RdyTS` is the timestamp of when the object posted. This allows the user to know when a semaphore or message queue posts.

If there are no objects posted, then `OSPendMulti()` places the current task in the wait list of all the objects that it is pending on. This is a complex and tedious process for `OSPendMulti()` since there can be other tasks in the pend list of some of these objects we are pending on.

To indicate how tricky things get, Figure 16-3 is an example of a task pending on two semaphores.

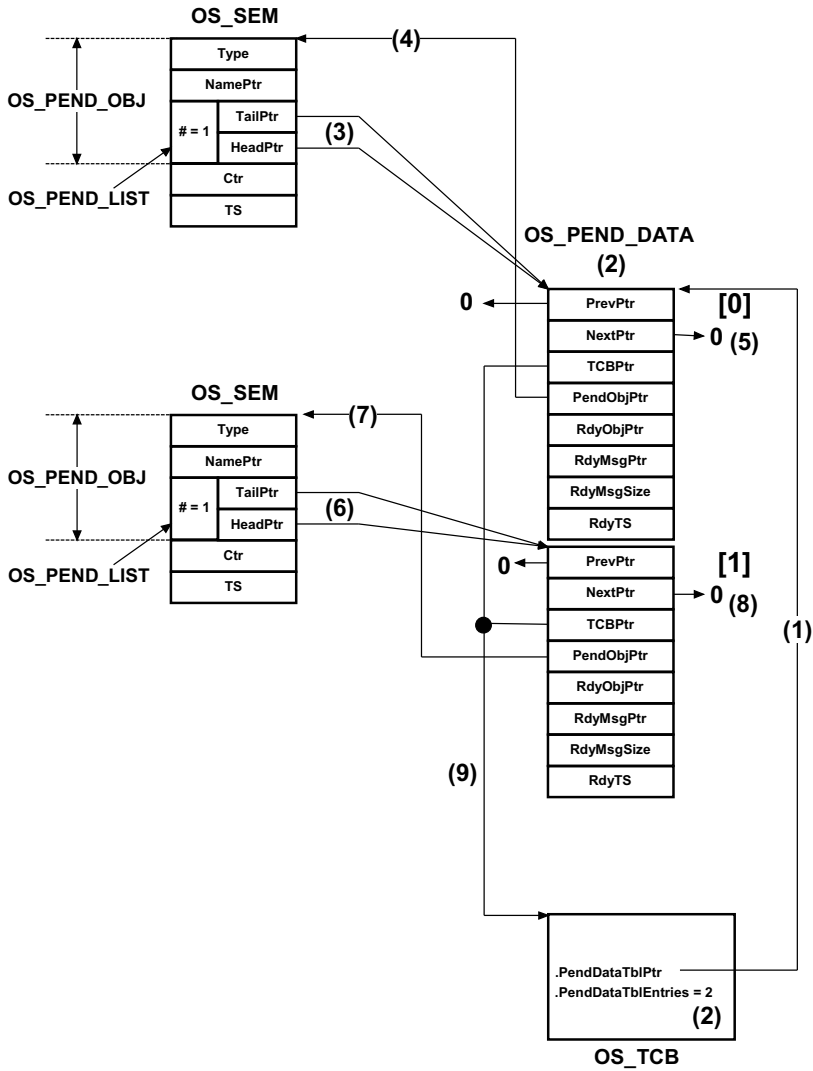

Figure 16-3 Task pending on two semaphores

F16-3(1) A pointer to the base address of the **OS\_PEND\_DATA** table is placed in the **OS\_TCB** of the task placed in the pend list of the two semaphores.

F16-3(2) The numbers of entries in the **OS\_PEND\_DATA** table are also placed in the **OS\_TCB**. Again, this task is waiting on two semaphores and therefore there are two entries in the table.



- F16-3(3) Entry [0] of the `OS_PEND_DATA` table is linked to the semaphore object specified by that entry's `.PendObjPtr`.
- F16-3(4) This pointer was specified by the caller of `OSPendMulti()`.
- F16-3(5) Since there is only one task in the pend list of the semaphore, the `.PrevPtr` and `.NextPtr` are pointing to `NULL`.
- F16-3(6) The second semaphore points to the second entry in the `OS_PEND_DATA` table.
- F16-3(7) This pointer was specified by the caller of `OSPendMulti()`.
- F16-3(8) The second semaphore only has one entry in its pend list. Therefore the `.PrevPtr` and `.NextPtr` both point to `NULL`.
- F16-3(9) `OSPendMulti()` links back each `OS_PEND_DATA` entry to the task that is waiting on the two semaphores.

Figure 16-4 is a more complex example where one task is pending on two semaphores while another task also pends on one of the two semaphores. The examples presented so far only show semaphores, but they could be combinations of semaphores and message queues.

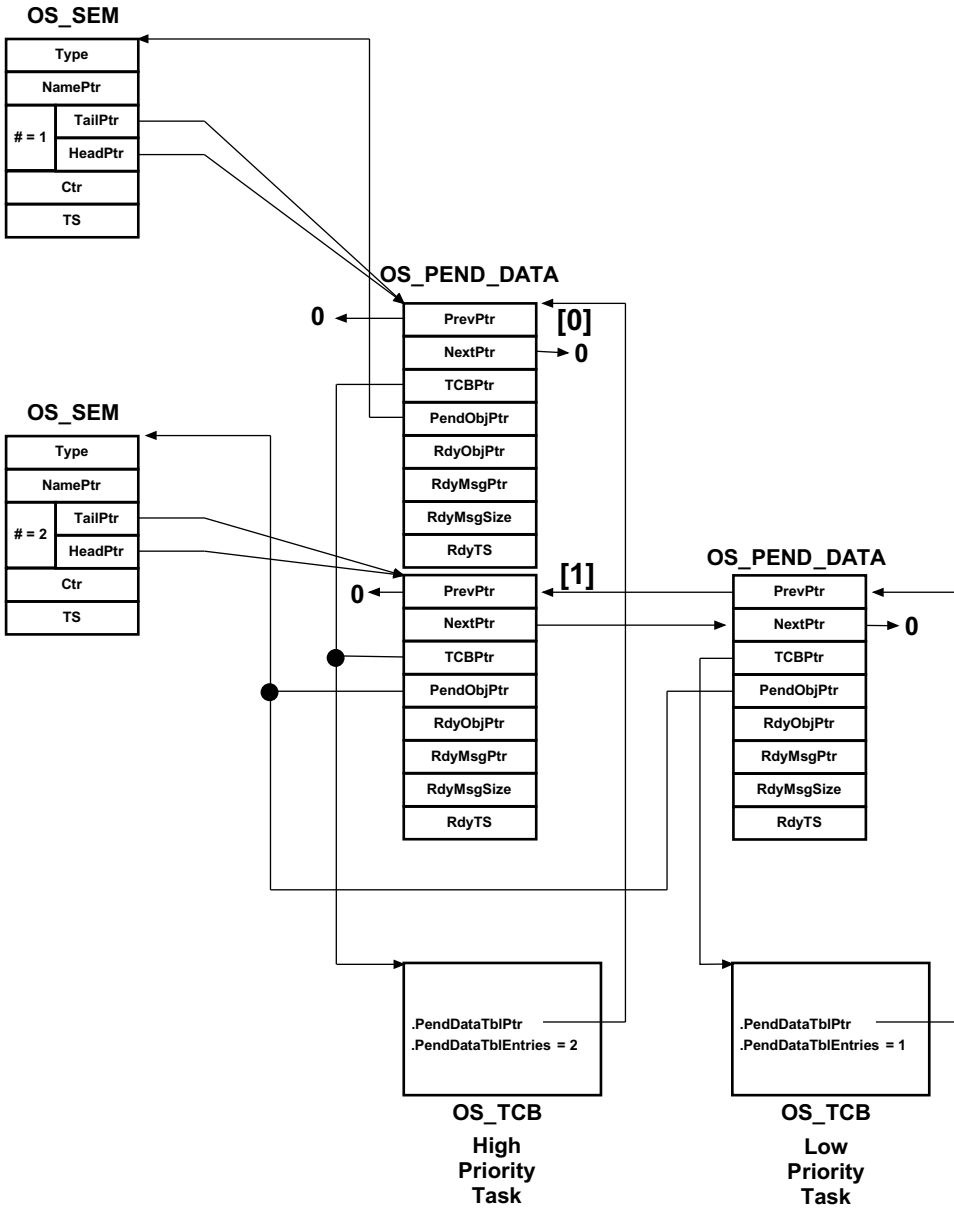

Figure 16-4 Tasks pending on semaphores

When either an ISR or a task signals or sends a message to one of the objects that the task is pending on, `OSPendMulti()` returns, indicating in the `OS_PEND_DATA` table which object was posted. This is done by only filling in “one” of the `.RdyObjPtr` entries, the one that corresponds to the object posted as shown in Figure 16-2.

Only one of the entries in the `OS_PEND_DATA` table will have a `.RdyObjPtr` with a non-NULL value while all the other entries have the `.RdyObjPtr` set to NULL. Going back to the case where a task waits on five semaphores and two message queues, if the first message queue is posted while the task is pending on all those objects, the `OS_PEND_DATA` table will be as shown in Figure 16-5.

|     | <code>.PrevPtr</code> | <code>.NextPtr</code> | <code>.TCBPtr</code> | <code>.PendObjPtr</code> | <code>.RdyObjPtr</code> | <code>.RdyMsgPtr</code> | <code>.RdyMsgSize</code> | <code>.RdyTS</code> |
|-----|-----------------------|-----------------------|----------------------|--------------------------|-------------------------|-------------------------|--------------------------|---------------------|
| [0] | 0                     | 0                     | TCBPtr               | PendObjPtr               | 0                       | 0                       | 0                        | 0                   |
| [1] | 0                     | 0                     | TCBPtr               | PendObjPtr               | 0                       | 0                       | 0                        | 0                   |
| [2] | 0                     | 0                     | TCBPtr               | PendObjPtr               | 0                       | 0                       | 0                        | 0                   |
| [3] | 0                     | 0                     | TCBPtr               | &MyQ1                    | &MyQ1                   | Msg Ptr                 | Msg Size                 | Timestamp           |
| [4] | 0                     | 0                     | TCBPtr               | PendObjPtr               | 0                       | 0                       | 0                        | 0                   |

Figure 16-5 Message queue #1 posted before timeout expired

## 16-1 SUMMARY

$\mu$ C/OS-III allows tasks to pend on multiple kernel objects.

`OSPendMulti()` can only pend on multiple semaphores and message queues, not event flags and mutual-exclusion semaphores.

If the objects are already posted when `OSPendMulti()` is called,  $\mu$ C/OS-III will specify which of the objects in the list of objects have already been posted.

If none of the objects are posted, `OSPendMulti()` will place the calling task in the pend list of all the desired objects. `OSPendMulti()` will return as soon as one of the objects is posted. In this case, `OSPendMulti()` will indicate which object was posted.

`OSPendMulti()` is a complex function that has potentially long critical sections.



# Chapter 17

## Memory Management

An application can allocate and free dynamic memory using any ANSI C compiler's `malloc()` and `free()` functions, respectively. However, using `malloc()` and `free()` in an embedded real-time system may be dangerous. Eventually, it might not be possible to obtain a single contiguous memory area due to fragmentation. Fragmentation is the development of a large number of separate free areas (i.e., the total free memory is fragmented into small, non-contiguous pieces). Execution time of `malloc()` and `free()` is generally nondeterministic given the algorithms used to locate a contiguous block of free memory.

$\mu$ C/OS-III provides an alternative to `malloc()` and `free()` by allowing an application to obtain fixed-sized memory blocks from a partition made from a contiguous memory area, as illustrated in Figure 17-1. All memory blocks are the same size, and the partition contains an integral number of blocks. Allocation and deallocation of these memory blocks is performed in constant time and is deterministic. The partition itself is typically allocated statically (as an array), but can also be allocated by using `malloc()` as long as it is never freed.

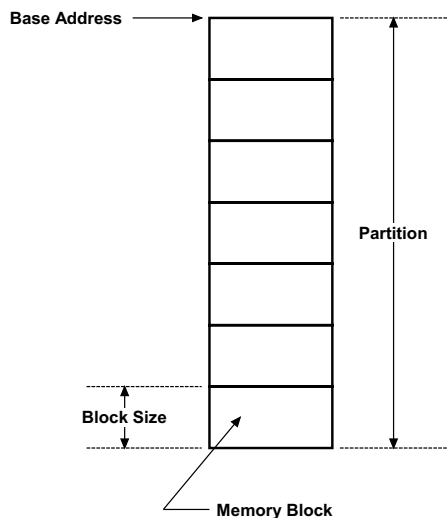

Figure 17-1 **Memory Partition**

As indicated in Figure 17-2, more than one memory partition may exist in an application and each one may have a different number of memory blocks and be a different size. An application can obtain memory blocks of different sizes based upon requirements. However, a specific memory block must always be returned to the partition that it came from. This type of memory management is not subject to fragmentation except that it is possible to run out of memory blocks. It is up to the application to decide how many partitions to have and how large each memory block should be within each partition.

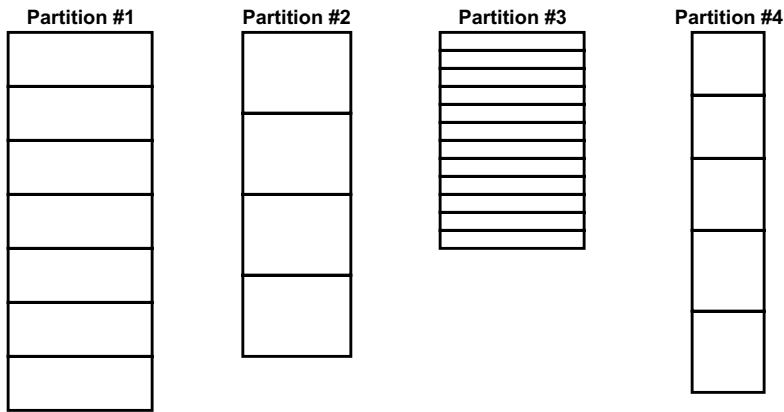

Figure 17-2 Multiple Memory Partitions

### 17-1 CREATING A MEMORY PARTITION

Before using a memory partition, it must be created. This allows  $\mu\text{C}/\text{OS-III}$  to know something about the memory partition so that it can manage their allocation and deallocation. Once created, a memory partition is as shown in Figure 17-3. Calling `OSMemCreate()` creates a memory partition.

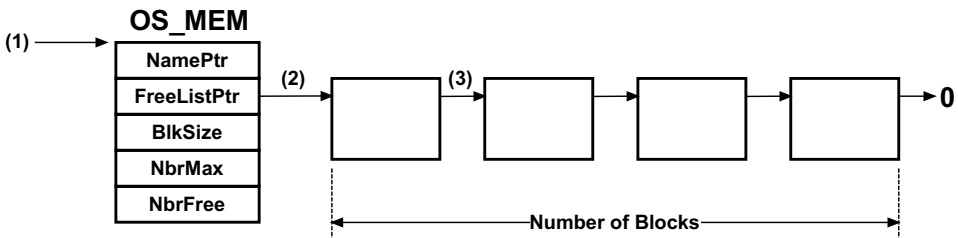

Figure 17-3 Created Memory Partition

- F17-3(1) When creating a partition, the application code supplies the address of a memory partition control block (**OS\_MEM**). Typically, this memory control block is allocated from static memory, however it can also be obtained from the heap by calling **malloc()**. The application code should however never deallocate it.
- F17-3(2) **OSMemCreate()** organizes the continuous memory provided into a singly linked list and stores the pointer to the beginning of the list in the **OS\_MEM** structure.
- F17-3(3) Each memory block must be large enough to hold a pointer. Given the nature of the linked list, a block needs to be able to point to the next block.

Listing 17-1 indicates how to create a memory partition with  $\mu$ C/OS-III.

```

OS_MEM      MyPartition;                (1)
CPU_INT08U  MyPartitionStorage[12][100]; (2)

void main (void)                        (3)
{
    OS_ERR  err;
    :
    :
    OSInit(&err);
    :
    OSMemCreate((OS_MEM  *)&MyPartition,      (4)
                (CPU_CHAR *)"My Partition",   (5)
                (void    *)&MyPartitionStorage[0][0], (6)
                (OS_MEM_QTY ) 12,             (7)
                (OS_MEM_SIZE)100,            (8)
                (OS_ERR   *)&err);           (9)
    /* Check 'err' */
    :
    :
    OSStart(&err);
}

```

Listing 17-1 **Creating a memory partition**

- L17-1(1) An application needs to allocate storage for a memory partition control block. This can be a static allocation as shown here or **malloc()** can be used in the code. However, the application code must not deallocate the memory control block.

- L17-1(2) The application also needs to allocate storage for the memory that will be split into memory blocks. This can also be a static allocation or `malloc()` can be used. The same reasoning applies. Do not deallocate this storage since other tasks may rely on the existence of this storage.
- L17-1(3) Memory partition must be created before allocating and deallocating blocks from the partition. One of the best places to create memory partitions is in `main()` prior to starting the multitasking process. Of course, an application can call a function from `main()` to do this instead of actually placing the code directly in `main()`.
- L17-1(4) Pass the address of the memory partition control block to `OSMemCreate()`. Never reference any of the internal members of the `OS_MEM` data structure. Instead, use  $\mu$ C/OS-III's API.
- L17-1(5) Assign a name to the memory partition. There is no limit to the length of the ASCII string as  $\mu$ C/OS-III saves a pointer to the ASCII string in the partition control block and not the actual characters.
- L17-1(6) Pass the base address of the storage area reserved for the memory blocks.
- L17-1(7) Specify how many memory blocks are available from this memory partition. Hard coded numbers are used for the sake of the illustration but one should instead use `#define` constants.
- L17-1(8) Specify the size of each memory block in the partition. Again, a hard coded value is used for illustration, which is not recommended in real code.
- L17-1(9) As with most  $\mu$ C/OS-III services, `OSMemCreate()` returns an error code indicating the outcome of the service. The call is successful if “`err`” contains `OS_ERR_NONE`.

Listing 17-2 shows how to create a memory partition with  $\mu$ C/OS-III, this time using `malloc()` to allocate storage. Do not deallocate the memory control block or the storage for the partition.



```

OS_MEM      *MyPartitionPtr;                                (1)

void main (void)
{
    OS_ERR   err;
    void     *p_storage;
    :
    OSInit(&err);
    :
    MyPartitionPtr = (OS_MEM *)malloc(sizeof(OS_MEM));      (2)
    if (MyPartitionPtr != (OS_MEM *)0) {
        p_storage = malloc(12 * 100);                       (3)
        if (p_storage != (void *)0) {
            OSMemCreate((OS_MEM *)MyPartitionPtr,          (4)
                        (CPU_CHAR *)"My Partition",
                        (void *)p_storage,                 (5)
                        (OS_MEM_QTY ) 12,                 (6)
                        (OS_MEM_SIZE)100,                 (6)
                        (OS_ERR *)&err);
            /* Check 'err' */
        }
    }
    :
    OSStart(&err);
}

```

Listing 17-2 **Creating a memory partition**

- L17-2(1) Instead of allocating static storage for the memory partition control block, assign a pointer that receives the `OS_MEM` allocated using `malloc()`.
- L17-2(2) The application allocates storage for the memory control block.
- L17-2(3) Allocate storage for the memory partition.
- L17-2(4) Pass a pointer to the allocated memory control block to `OSMemCreate()`.
- L17-2(5) Pass the base address of the storage used for the partition.
- L17-2(6) Finally, pass the number of blocks and the size of each block so that  $\mu\text{C}/\text{OS-III}$  creates the linked list of 12 blocks of 100 bytes each. Again, hard coded numbers are used, but these would typically be replaced by `#defines`.

## 17-2 GETTING A MEMORY BLOCK FROM A PARTITION

Application code can request a memory block from a partition by calling `OSMemGet()` as shown in Listing 17-3. The code assumes that the partition was already created.

```
OS_MEM      MyPartition;                                (1)
CPU_INT08U  *MyDataBlkPtr;

void MyTask (void *p_arg)
{
    OS_ERR  err;

    :
    while (DEF_ON) {
        :
        MyDataBlkPtr = (CPU_INT08U *)OSMemGet((OS_MEM  *)&MyPartition, (2)
                                              (OS_ERR  *)&err);
        if (err == OS_ERR_NONE) {
            /* You have a memory block from the partition */
            (3)
        }
        :
        :
    }
}
```

Listing 17-3 Obtaining a memory block from a partition

- L17-3(1) The memory partition control block must be accessible by all tasks or ISRs that will be using the partition.
- L17-3(2) Simply call `OSMemGet()` to obtain a memory block from the desired partition. A pointer to the allocated memory block is returned. This is similar to `malloc()`, except that the memory block comes from a pool that is guaranteed to not fragment.
- L17-3(3) It is important to examine the returned error code to ensure that there are free memory blocks and that the application can start putting content in the memory blocks.

## 17-3 RETURNING A MEMORY BLOCK TO A PARTITION

The application code must return an allocated memory block back to the proper partition when finished. Do this by calling `OSMemPut()` as shown in Listing 17-4. The code assumes that the partition was already created.

```
OS_MEM      MyPartition;                (1)
CPU_INT08U  *MyDataBlkPtr;

void MyTask (void *p_arg)
{
    OS_ERR  err;

    :
    while (DEF_ON) {
        :
        OSMemPut((OS_MEM *)&MyPartition,    (2)
                (void *)MyDataBlkPtr,      (3)
                (OS_ERR *)&err);
        if (err == OS_ERR_NONE) {          (4)
            /* You properly returned the memory block to the partition */
        }
        :
        :
    }
}
```

Listing 17-4 Returning a memory block to a partition

- L17-4(1) The memory partition control block must be accessible by all tasks or ISRs that will be using the partition.
- L17-4(2) Simply call `OSMemPut()` to return the memory block back to the memory partition. Note that there is no check to see whether the proper memory block is being returned to the proper partition (assuming you have multiple different partitions). It is therefore important to be careful (as is necessary when designing embedded systems).
- L17-4(3) Pass the pointer to the data area that is allocated so that it can be returned to the pool. Note that a “`void *`” is assumed.
- L17-4(4) Examine the returned error code to ensure that the call was successful.

## 17-4 USING MEMORY PARTITIONS

Memory management services are enabled at compile time by setting the configuration constant `OS_CFG_MEM_EN` to 1 in `OS_CFG.H`.

There are a number of operations to perform on memory partitions as summarized in Table 13-1.

| Function Name              | Operation                                      |
|----------------------------|--|
| <code>OSMemCreate()</code> | Create a memory partition.                     |
| <code>OSMemGet()</code>    | Obtain a memory block from a memory partition. |
| <code>OSMemPut()</code>    | Return a memory block to a memory partition.   |

Table 17-1 **Memory Partition API summary**

`OSMemCreate()` can only be called from task-level code, but `OSMemGet()` and `OSMemPut()` can be called by Interrupt Service Routines (ISRs).

Listing 17-4 shows an example of how to use the dynamic memory allocation feature of  $\mu\text{C}/\text{OS-III}$ , as well as message-passing capabilities (see Chapter 15, “Message Passing” on page 289). In this example, the task on the left reads and checks the value of analog inputs (pressures, temperatures, and voltage) and sends a message to the second task if any of the analog inputs exceed a threshold. The message sent contains information about which channel had the error, an error code, an indication of the severity of the error, and other information.

Error handling in this example is centralized. Other tasks, or even ISRs, can post error messages to the error-handling task. The error-handling task could be responsible for displaying error messages on a monitor (a display), logging errors to a disk, or dispatching other tasks to take corrective action based on the error.

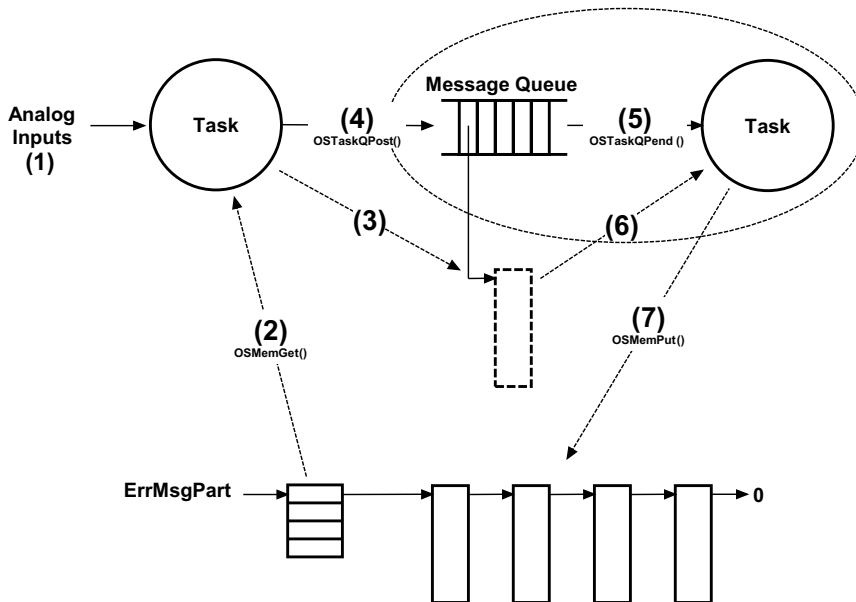

Figure 17-4 Using a Memory Partition – non blocking

- F17-4(1) The analog inputs are read by the task. The task determines that one of the inputs is outside a valid range and an error message needs to be sent to the error handler.
- F17-4(2) The task then obtains a memory block from a memory partition so that it can place information regarding the detected error.
- F17-4(3) The task writes this information to the memory block. As mentioned above, the task places the analog channel that is at fault, an error code, an indication of the severity, possible solutions, and more. There is no need to store a timestamp in the message, as time stamping is a built-in feature of  $\mu\text{C}/\text{OS-III}$  so the receiving task will know when the message was posted.
- F17-4(4) Once the message is complete, it is posted to the task that will handle such error messages. Of course the receiving task needs to know how the information is placed in the message. Once the message is sent, the analog input task is no longer allowed (by convention) to access the memory block since it sent it out to be processed.

- F17-4(5) The error handler task (on the right) normally pends on the message queue. This task will not execute until a message is sent to it.
- F17-4(6) When a message is received, the error handler task reads the contents of the message and performs necessary action(s). As indicated, once sent, the sender will not do anything else with the message.
- F17-4(7) Once the error handler task is finished processing the message, it simply returns the memory block to the memory partition. The sender and receiver therefore need to know about the memory partition or, the sender can pass the address of the memory partition as part of the message and the error handler task will know where to return the memory block.

Sometimes it is useful to have a task wait for a memory block in case a partition runs out of blocks.  $\mu\text{C}/\text{OS-III}$  does not support pending on partitions, but it is possible to support this requirement by adding a counting semaphore (see Chapter 13, “Resource Management” on page 209) to guard the memory partition. This is illustrated in Figure 17-5.

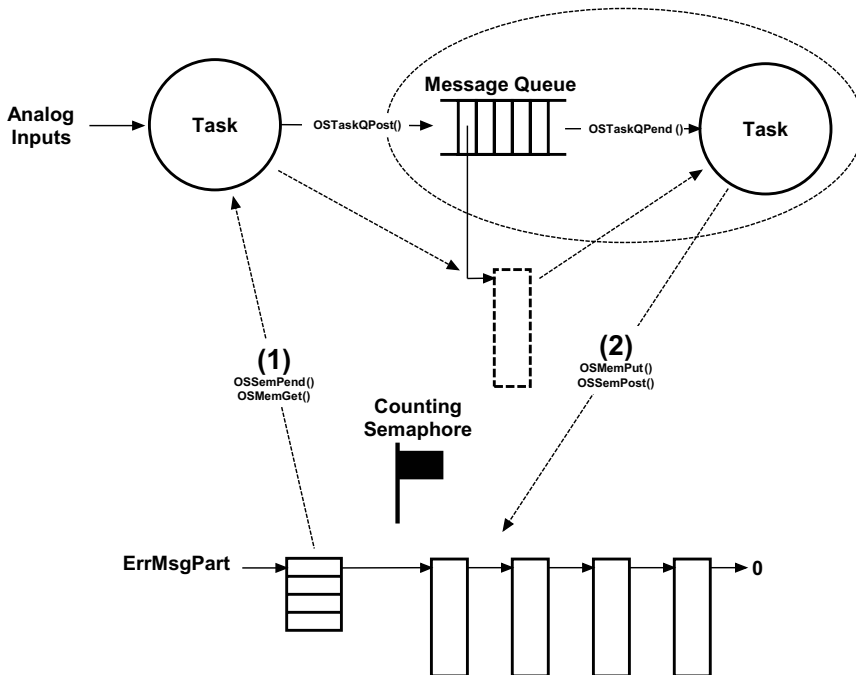

Figure 17-5 Using a Memory Partition - blocking

- F17-5(1) To obtain a memory block, simply obtain the semaphore by calling `OSSemPend()` and call `OSMemGet()` to receive the memory block.
- F17-5(2) To release a block, simply return the memory block by calling `OSMemPut()` and signal the semaphore by calling `OSSemPost()`.

The above operations must be performed in order.

Note that the user may call `OSMemGet()` and `OSMemPut()` from an ISR since these functions do not block and in fact, execute very quickly. However, you cannot use blocking calls from ISRs.

## 17-5 SUMMARY

Do not use `malloc()` and `free()` in embedded systems since they lead to fragmentation.

It is possible to use `malloc()` to allocate memory from the heap, but do not deallocate the memory.

The application programmer can create an unlimited number of memory partitions (limited only by the amount of available RAM).

Memory partition services in  $\mu$ C/OS-III start with the `OSMem???` prefix, and the services available to the application programmer are described in Appendix A, “ $\mu$ C/OS-III API Reference Manual” on page 375.

Memory management services are enabled at compile time by setting the configuration constant `OS_CFG_MEM_EN` to 1 in `OS_CFG.H`.

`OSMemGet()` and `OSMemPut()` can be called from ISRs.





Porting  $\mu\text{C}/\text{OS-III}$ 

This chapter describes in general terms how to adapt  $\mu\text{C}/\text{OS-III}$  to different processors. Adapting  $\mu\text{C}/\text{OS-III}$  to a microprocessor or a microcontroller is called porting. Most of  $\mu\text{C}/\text{OS-III}$  is written in C for portability. However, it is still necessary to write processor-specific code in C and assembly language.  $\mu\text{C}/\text{OS-III}$  manipulates processor registers, which can only be done using assembly language. Porting  $\mu\text{C}/\text{OS-III}$  to different processors is relatively easy as  $\mu\text{C}/\text{OS-III}$  was designed to be portable and, since  $\mu\text{C}/\text{OS-III}$  is similar to  $\mu\text{C}/\text{OS-II}$ , the user can start from a  $\mu\text{C}/\text{OS-II}$  port. If there is already a port for the processor to be used, it is not necessary to read this chapter unless, of course, there is an interest in knowing how  $\mu\text{C}/\text{OS-III}$  processor-specific code works.

$\mu\text{C}/\text{OS-III}$  can run on a processor if it satisfies the following general requirements:

- The processor has an ANSI C compiler that generates reentrant code.
- The processor supports interrupts and can provide an interrupt that occurs at regular intervals (typically between 10 and 1000 Hz).
- Interrupts can be disabled and enabled.
- The processor supports a hardware stack that accommodates a fair amount of data (possibly many kilobytes).
- The processor has instructions to save and restore the stack pointer and other CPU registers, either on the stack or in memory.
- The processor has access to sufficient RAM for  $\mu\text{C}/\text{OS-III}$ 's variables and data structures as well as internal task stacks.
- The compiler should support 64-bit data types (typically “long long”).

Figure 18-1 shows the  $\mu$ C/OS-III architecture and its relationship with other software components and hardware. When using  $\mu$ C/OS-III in an application, the user is responsible for providing application software and  $\mu$ C/OS-III configuration sections.

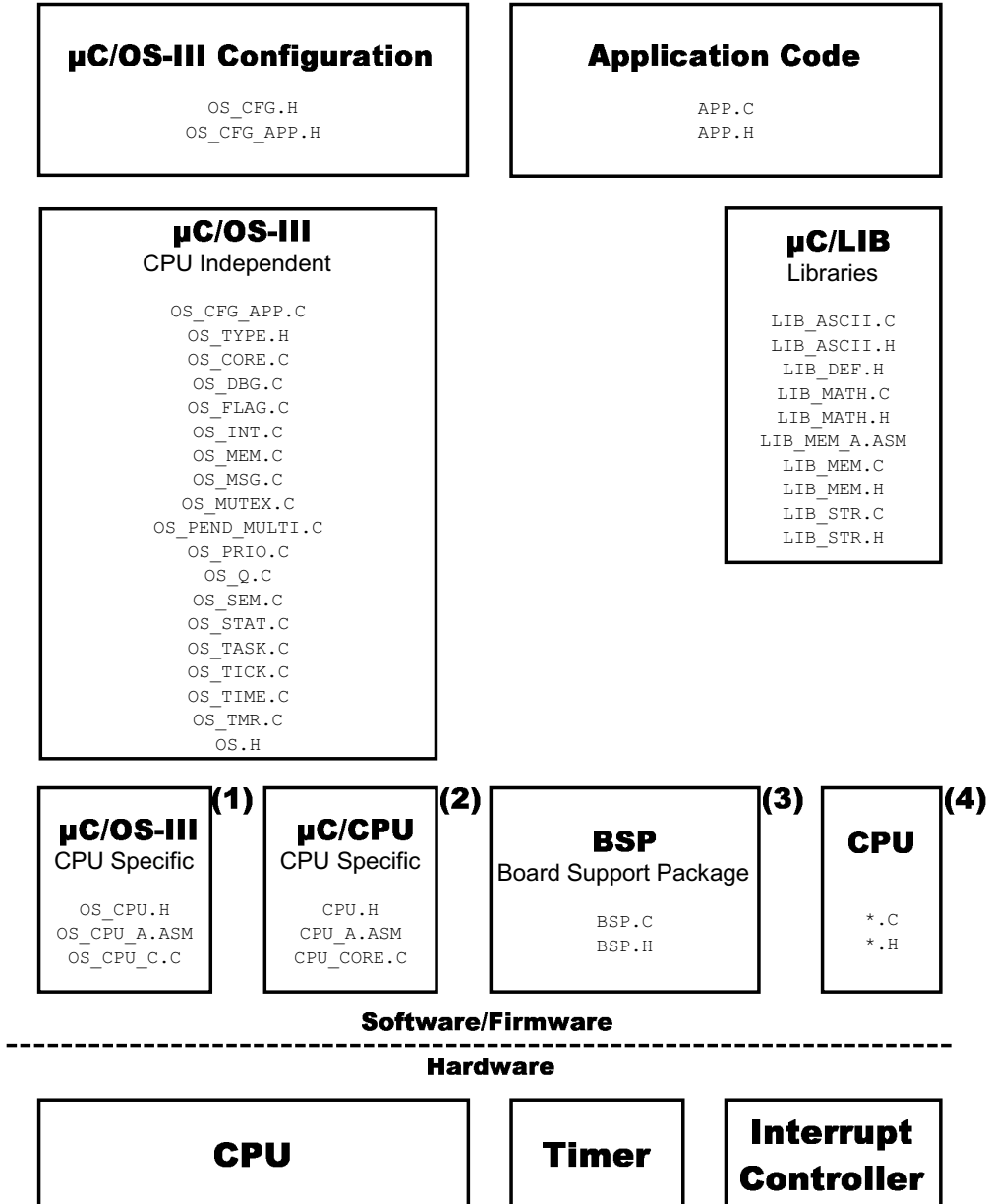

Figure 18-1  $\mu$ C/OS-III architecture

- 
- F18-1(1) A  $\mu$ C/OS-III port consists of writing or changing the contents of three kernel-specific files: `OS_CPU.H`, `OS_CPU_A.ASM` and `OS_CPU_C.C`.
- F18-1(2) A port also involves writing or changing the contents of three CPU specific files: `CPU.H`, `CPU_A.ASM` and `CPU_CORE.C`.
- F18-1(3) A Board Support Package (BSP) is generally necessary to interface  $\mu$ C/OS-III to a timer (which is used for the clock tick) and an interrupt controller.
- F18-1(4) Some semiconductor manufacturers provide source and header files to access on-chip peripherals. These are contained in CPU/MCU specific files.

Porting  $\mu$ C/OS-III is quite straightforward once the subtleties of the target processor and the C compiler/assembler are understood. Depending on the processor, a port consists of writing or changing between 100 and 400 lines of code, which takes a few hours to a few days to accomplish. The easiest thing to do, however, is to modify an existing port from a processor that is similar to the one intended for use.

A  $\mu$ C/OS-III port looks very much like a  $\mu$ C/OS-II port. Since  $\mu$ C/OS-II was ported to well over 45 different CPU architectures it is easy to start from a  $\mu$ C/OS-II port. Converting a  $\mu$ C/OS-II port to  $\mu$ C/OS-III takes approximately an hour. The process is described in Appendix C, "Migrating from  $\mu$ C/OS-II to  $\mu$ C/OS-III" on page 599.

A port involves three aspects: CPU, OS and board-specific code. The board-specific code is often called a *Board Support Package* (BSP) and from  $\mu$ C/OS-III's point of view, requires very little.

## 18-1 $\mu$ C/CPU

CPU-specific code is related to the CPU and the compiler in use, and less so with  $\mu$ C/OS-III. For example, disabling and enabling interrupts and the word width of the stack, whether the stack grows from high-to-low memory or from low-to-high memory and more are all CPU specific and not OS specific. Micrium encapsulates CPU functions and data types into a module called  $\mu$ C/CPU.

Table 18-1 shows the name of  $\mu$ C/CPU files and where they should be placed on the computer used to develop a  $\mu$ C/OS-III-based application.

| File       | Directory  |
|------------|--|
| CPU_DEF.H  | \Micrium\Software\uC-CPU\                        |
| CPU.H      | \Micrium\Software\uC-CPU\<<processor>\<compiler> |
| CPU_C.C    | \Micrium\Software\uC-CPU\<<processor>\<compiler> |
| CPU_CFG.H  | \Micrium\Software\uC-CPU\CFG\TEMPLATE            |
| CPU_CORE.C | \Micrium\Software\uC-CPU\                        |
| CPU_CORE.H | \Micrium\Software\uC-CPU\                        |
| CPU_A.ASM  | \Micrium\Software\uC-CPU\<<processor>\<compiler> |

Table 18-1  $\mu$ C/CPU files and directories

Here, <processor> is the name of the processor that the CPU\*.\* files apply to, and <compiler> is the name of the compiler that these files assume because of different assembly language directives that different tool chains use.

The above source files for the CPU that came with this book are found when downloading the code from the Micrium website.

### CPU\_DEF.H

This file should not require any changes. CPU\_DEF.H declares #define constants that are used by Micrium software components.

**CPU.H**

Many CPUs have different word lengths and **CPU.H** declares a series of type definitions that ensure portability. Specifically, at Micrium, C data types **int**, **short**, **long**, **char**, *etc.*, are not used. Instead, clearer data types are defined. Consult compiler documentation to determine whether the standard declarations described below must be changed for the CPU/compiler used. When using a 32-bit CPU, the declarations below should work without change.

```

typedef          void          CPU_VOID;
typedef unsigned char          CPU_CHAR;
typedef unsigned char          CPU_BOOLEAN;
typedef unsigned char          CPU_INT08U;
typedef signed   char          CPU_INT08S;
typedef unsigned short         CPU_INT16U;
typedef signed   short         CPU_INT16S;
typedef unsigned int           CPU_INT32U;
typedef signed   int           CPU_INT32S;
typedef unsigned long long     CPU_INT64U;
typedef signed   long long     CPU_INT64S;
typedef          float         CPU_FP32;
typedef          double        CPU_FP64;
typedef volatile CPU_INT08U    CPU_REG08;
typedef volatile CPU_INT16U    CPU_REG16;
typedef volatile CPU_INT32U    CPU_REG32;
typedef volatile CPU_INT64U    CPU_REG64;
typedef          void          (*CPU_FNCT_VOID)(void);
typedef          void          (*CPU_FNCT_PTR )(void *);
typedef CPU_INT32U             CPU_ADDR;
typedef CPU_INT32U             CPU_DATA;
typedef CPU_DATA               CPU_ALIGN;
typedef CPU_ADDR               CPU_SIZE_T;
typedef CPU_INT32U             CPU_STK;           (1)
typedef CPU_ADDR               CPU_STK_SIZE;
typedef CPU_INT16U             CPU_ERR;
typedef CPU_INT32U             CPU_SR;           (2)
typedef CPU_INT32U             CPU_TS;           (3)

```

- (1) Especially important for  $\mu$ C/OS-III is the definition of the **CPU\_STK** data type, which sets the width of a stack entry. Specifically, is the width of data pushed to and popped from the stack 8 bits, 16 bits, 32 bits or 64 bits?
- (2) **CPU\_SR** defines the data type for the processor's status register (SR) that generally holds the interrupt disable status.
- (3) The **CPU\_TS** is a time stamp used to determine when an operation occurred, or to measure the execution time of code.

**CPU.H** also declares macros to disable and enable interrupts: **CPU\_CRITICAL\_ENTER()** and **CPU\_CRITICAL\_EXIT()**, respectively. Finally, **CPU.H** declares function prototypes for a number of functions found in either **CPU\_C.C** or **CPU\_CORE.C**.

### **CPU\_C.C**

This is an optional file containing CPU-specific functions to set the interrupt controller, timer prescalers, and more. Most implementations will not contain this file.

### **CPU\_CFG.H**

This is a configuration file to be copied into the product directory and changed based on the options to exercise in  $\mu$ C/CPU. The file contains **#define** constants that may need to be changed based on the desired use of  $\mu$ C/CPU. For example, to assign a “name” to the CPU, the name can be queried and displayed. Also, to name the CPU, one must specify the length of the ASCII string.

### **CPU\_CORE.C**

This file is generic and does not need to be changed. However it must be included in all builds. **CPU\_CORE.C** defines such functions as **CPU\_Init()**, **CPU\_CntLeadZeros()**, and code to measure maximum CPU interrupt disable time.

**CPU\_Init()** must be called before calling **OSInit()**.

**CPU\_CntLeadZeros()** is used by the  $\mu$ C/OS-III scheduler to find the highest priority ready task (see Chapter 7, “Scheduling” on page 133). **CPU\_CORE.C** implements a count leading zeros in C. However, if the processor used provides a built-in instruction to count leading zeros, define

**CPU\_CFG\_LEAD\_ZEROS\_ASM\_PRESENT**, and replace this function by an assembly language equivalent (in **CPU\_A.ASM**). It is important to properly declare **CPU\_CFG\_DATA\_SIZE** in **CPU.H** for this function to work.

**CPU\_CORE.C** also includes code that allows you to read timestamps.  $\mu$ C/CPU timestamps (**CPU\_TS**) are 32-bit values. However,  $\mu$ C/CPU can return a 64-bit timestamp since  $\mu$ C/CPU keeps track of overflows of the low part of the 64-bit timestamp. Also use timestamps to determine when events occur, or to measure the execution time of code. Timestamp support requires a 16- or 32-bit free-running counter/timer that can be read. The code to read this timer will be placed in the BSP (Board Support Package) of the evaluation board or target board used.

**CPU\_CORE.H**

This header file is required by `CPU_CORE.C` to define function prototypes.

**CPU\_A.ASM**

This file contains assembly language code to implement such functions as disabling and enabling interrupts, a more efficient count leading zeros function, and more. At a minimum, this file should implement `CPU_SR_Save()` and `CPU_SR_Restore()`.

`CPU_SR_Save()` reads the current value of the CPU status register where the current interrupt disable flag resides and returns this value to the caller. However, before returning, `CPU_SR_Save()` must disable all interrupts. `CPU_SR_Save()` is actually called by the macro `CPU_CRITICAL_ENTER()`.

`CPU_SR_Restore()` restores the CPU's status register to a previously saved value. `CPU_SR_Restore()` is called from the macro `CPU_CRITICAL_EXIT()`.

**18-2  $\mu$ C/OS-III PORT**

Table 18-2 shows the name of  $\mu$ C/OS-III files and where they are typically found.

| File                      | Directory   |
|---------------------------|---|
| <code>OS_CPU.H</code>     | <code>\Micrium\Software\uCOS-III\Ports\&lt;processor&gt;\&lt;compiler&gt;\</code> |
| <code>OS_CPU_A.ASM</code> | <code>\Micrium\Software\uCOS-III\Ports\&lt;processor&gt;\&lt;compiler&gt;\</code> |
| <code>OS_CPU_C.C</code>   | <code>\Micrium\Software\uCOS-III\Ports\&lt;processor&gt;\&lt;compiler&gt;\</code> |

Table 18-2  $\mu$ C/OS-III files and directories

Here, `<processor>` is the name of the processor that the `OS_CPU*.*` files apply to, and `<compiler>` is the name of the compiler that these files assume because of the different assembly language directives that different tool chains use.

**OS\_CPU.H**

This file must define the macro `OS_TASK_SW()`, which is called by `OSSched()` to perform a task-level context switch. The macro can translate directly to a call to `OSCtxSw()`, trigger a software interrupt, or a `TRAP`. The choice depends on the CPU architecture.

`OS_CPU.H` must also define the macro `OS_TS_GET()` which obtains the current time stamp. It is expected that the time stamp is type `CPU_TS`, which is typically declared as at least a 32-bit value.

`OS_CPU.H` also defines function prototypes for `OSCtxSw()`, `OSIntCtxSw()`, `OSStartHighRdy()` and possibly other functions required by the port.

### **OS\_CPU\_A.ASM**

This file contains the implementation of the following assembly language functions:

```
OSStartHighRdy()  
OSCtxSw()  
OSIntCtxSw()
```

and optionally,

```
OSTickISR()
```

`OSTickISR()` may optionally be placed in `OS_CPU_A.ASM` if it does not change from one product to another. The functions in this file are implemented in assembly language since they manipulate CPU registers, which is typically not possible from C. The functions are described in Appendix A, “ $\mu$ C/OS-III API Reference Manual” on page 375.

### **OS\_CPU\_C.C**

This file contains the implementation of the following C functions:

```
OSIdleTaskHook()  
OSInitHook()  
OSStatTaskHook()  
OSTaskCreateHook()  
OSTaskDelHook()  
OSTaskReturnHook()  
OSTaskStkInit()  
OSTaskSwHook()  
OSTimeTickHook()
```

The functions are described in Appendix A, “ $\mu$ C/OS-III API Reference Manual” on page 375. `OS_CPU_C.C` can declare other functions as needed by the port, however the above functions are mandatory.



---

## 18-3 BOARD SUPPORT PACKAGE (BSP)

A board support package refers to code associated with the actual evaluation board or the target board used. For example, the BSP defines functions to turn LEDs on or off, reads push-button switches, initializes peripheral clocks, etc., providing nearly any functionality to multiple products/projects.

Names of typical BSP files include:

```
BSP.C
BSP.H
BSP_INT.C
BSP_INT.H
```

All files are generally placed in a directory as follows:

```
\Micrium\Software\EvalBoards\<<manufacturer>\
<board_name>\<compiler>\BSP\
```

Here, `<manufacturer>` is the name of the evaluation board or target board manufacturer, `<board_name>` is the name of the evaluation or target board and `<compiler>` is the name of the compiler that these files assume, although most should be portable to different compilers since the BSP is typically written in C.

### **BSP.C and BSP.H**

These files normally contain functions and their definitions such as `BSP_Init()`, `BSP_LED_On()`, `BSP_LED_Off()`, `BSP_LED_Toggle()`, `BSP_PB_Rd()`, and others. It is up to the user to decide if the functions in this file start with the prefix `BSP_`. In other words, use `LED_On()` and `PB_Rd()` if this is clearer. However, it is a good practice to encapsulate this type of functionality in a BSP type file.

In `BSP.C`, add `CPU_TS_TmrInit()` to initialize the  $\mu$ C/CPU timestamp feature. This function must return the number 16 if using a 16-bit timer and 0 for a 32-bit timer.

`CPU_TS_TmrGet()` is responsible for reading the value of a 16- or 32-bit free-running timer. If the timer is 16 bits, this function will need to return the value of the timer, but shifted to the left 16 places so that it looks like a 32-bit timer. If the timer is 32 bits, simply return the

current value of the timer. Note that the timer is assumed to be an up counter. If the timer counts down, the BSP code will need to return the ones-complement of the timer value (prior to the shift).

### **BSP\_INT.C and BSP\_INT.H**

These files are typically used to declare interrupt controller related functions. For example, code that enables or disables specific interrupts from the interrupt controller, acknowledges the interrupt controller, and code to handle all interrupts if the CPU vectors to a single location when an interrupt occurs (see Chapter 9, “Interrupt Management” on page 157). The pseudo code below shows an example of the latter.

```
void BSP_IntHandler (void) (1)
{
    CPU_FNCT_VOID p_isr;

    while (interrupts being asserted) { (2)
        p_isr = Read the highest priority interrupt from the controller; (3)
        if (p_isr != (CPU_FNCT_VOID)0) { (4)
            (*p_isr)(); (5)
        }
        Acknowledge interrupt controller; (6)
    }
}
```

- (1) Here assume that the handler for the interrupt controller is called from the assembly language code that saves the CPU registers upon entering an ISR (see Chapter 9, “Interrupt Management” on page 157).
- (2) The handler queries the interrupt controller to ask it for the address of the ISR that needs to be executed in response to the interrupt. Some interrupt controllers return an integer value that corresponds to the source. In this case, simply use this integer value as an index into a table (RAM or ROM) where those vectors are placed.
- (3) The interrupt controller is asked to provide the highest priority interrupt pending. It is assumed here that the CPU may receive multiple simultaneous interrupts (or closely spaced interrupts), and that the interrupt will prioritize the interrupts received. The CPU will then service each interrupt in priority order instead of on a first-come basis. However, the scheme used greatly depends on the interrupt controller itself.

- (4) Check to ensure that the interrupt controller did not return a **NULL** pointer.
- (5) Simply call the ISR associated with the interrupt device.
- (6) The interrupt controller generally needs to be acknowledged so that it knows that the interrupt presented is taken care of.

## **18-4 SUMMARY**

A port involves three aspects: CPU, OS and board specific (BSP) code.

$\mu$ C/OS-III port consists of writing or changing the contents of three kernel specific files: **OS\_CPU.H**, **OS\_CPU\_A.ASM** and **OS\_CPU\_C.C**.

It is necessary to write or change the content of three CPU specific files: **CPU.H**, **CPU\_A.ASM** and **CPU\_C.C**.

Finally create or change a Board Support Package (BSP) for the evaluation board or target board being used.

A  $\mu$ C/OS-III port is similar to a  $\mu$ C/OS-II port, therefore start from one of the many  $\mu$ C/OS-II ports already available (see Appendix C, “Migrating from  $\mu$ C/OS-II to  $\mu$ C/OS-III” on page 599).



## Run-Time Statistics

$\mu\text{C}/\text{OS-III}$  performs substantial run-time statistics that can be displayed by kernel-aware debuggers and/or  $\mu\text{C}/\text{Probe}$ . Specifically, it is possible to ascertain the total number of context switches, maximum interrupt disable time, maximum scheduler lock time, CPU usage, stack space used on a per-task basis, the RAM used by  $\mu\text{C}/\text{OS-III}$ , and much more.

No other real-time kernel provides as much run-time information as  $\mu\text{C}/\text{OS-III}$ . This information is quite useful during debugging as it provides a sense of how well an application is running and the resources being used.

$\mu\text{C}/\text{OS-III}$  also provides information about the configuration of the system. Specifically, the amount of RAM used by  $\mu\text{C}/\text{OS-III}$ , including all internal variables and task stacks.

The  $\mu\text{C}/\text{OS-III}$  variables described in this chapter should be displayed and never changed.

## 19-1 GENERAL STATISTICS – RUN-TIME

The following is a list of  $\mu$ C/OS-III variables that are not associated to any specific task:

### **OSCfg\_TickWheel[i].NbrEntries**

The tick wheel contains up to `OS_CFG_TICK_WHEEL_SIZE` “spokes” (see `OS_CFG_APP.H`), and each spoke contains the `.NbrEntries` field, which holds the current number of entries in that spoke.

### **OSCfg\_TickWheel[i].NbrEntriesMax**

The `.NbrEntriesMax` field holds the maximum (i.e., peak) number of entries in a spoke.

### **OSCfg\_TmrWheel[i].NbrEntries**

The tick wheel contains up to `OS_CFG_TMR_WHEEL_SIZE` “spokes” (see `OS_CFG_APP.H`), and each spoke contains the `.NbrEntries` field, which holds the current number of entries in that spoke.

### **OSCfg\_TmrWheel[i].NbrEntriesMax**

The `.NbrEntriesMax` field holds the maximum (i.e., peak) number of entries in a spoke.

### **OSIdleTaskCtr**

This variable contains a counter that is incremented every time the idle task infinite loop runs.

### **OSIntNestingCtr**

This variable contains the interrupt nesting level. 1 means servicing the first level of interrupt nesting, 2 means the interrupt was interrupted by another interrupt, etc.

### **OSIntDisTimeMax**

This variable contains the maximum interrupt disable time (in `CPU_TS` units).

### **OSRunning**

This variable indicates that multitasking has started.

### **OSIntQNrEntries**

This variable indicates the current number of entries in the interrupt handler queue.

**OSIntQOvfCtr**

This variable shows the number of attempts to post a message from an interrupt to the interrupt handler queue, and there was not enough room to place the post call. In other words, how many times an interrupt was not being able to be serviced by its corresponding task. This value should always be 0 if the interrupt handler queue is sized large enough. If the value is non-zero, increase the size of the interrupt handler queue. A non-zero value may also indicate that the processor is not fast enough.

**OSIntQTaskTimeMax**

This variable contains the maximum execution time of the Interrupt Queue Handler Task (in CPU\_TS units).

**OSFlagQty**

This variable indicates the number of event flag groups created. This variable is only declared if OS\_CFG\_FLAG\_EN is set to 1 in OS\_CFG.H.

**OSMemQty**

This variable indicates the number of fixed-sized memory partitions created by the application. This variable is only declared if OS\_CFG\_MEM\_EN is set to 1 in OS\_CFG.H.

**OSMsgPool.NbrFree**

The variable indicates the number of free OS\_MSGs in the message pool. This number should never be zero since that indicate that the application is no longer able to send messages. This variable is only declared if OS\_CFG\_Q\_EN is set to 1, or OS\_CFG\_TASK\_Q\_EN is set to 1 in OS\_CFG.H.

**OSMsgPool.NbrUsed**

This variable indicates the number of OS\_MSGs currently used by the application. This variable is only declared if OS\_CFG\_Q\_EN is set to 1, or OS\_CFG\_TASK\_Q\_EN is set to 1 in OS\_CFG.H.

**OSMutexQty**

This variable indicates the number of mutual exclusion semaphores created by the application. This variable is only declared if OS\_CFG\_MUTEX\_EN is set to 1 in OS\_CFG.H.

**OSRdyList[i].NbrEntries**

It is useful to examine how many entries there are in the ready list at each priority.

### **OSSchedLockTimeMax**

This variable indicates the maximum amount of time the scheduler was locked irrespective of which task did the locking. It represents the global scheduler lock time. This value is expressed in `CPU_TS` units. The variable is only declared if `OS_CFG_SCHED_LOCK_TIME_MEAS_EN` is set to 1 in `OS_CFG.H`.

### **OSSchedLockTimeMaxCur**

This variable indicates the maximum amount of time the scheduler was locked. This value is expressed in `CPU_TS` units and is reset by the context switch code so that it can track the scheduler lock time on a per-task basis. This variable is only declared if `OS_CFG_SCHED_LOCK_TIME_MEAS_EN` is set to 1 in `OS_CFG.H`.

### **OSSchedLockNestingCtr**

This variable keeps track of the nesting level of the scheduler lock.

### **OSSchedRoundRobinEn**

This variable indicates whether or not round robin scheduling is enabled.

### **OSSemQty**

This variable indicates the number of semaphores created by your application. This variable is only declared if `OS_CFG_SEM_EN` is set to 1 in `OS_CFG.H`.

### **OSStatTaskCPUUsage**

This variable indicates the CPU usage of the application expressed as a percentage. A value of 10 indicates that 10% of the CPU is used, while 90% of the time the CPU is idling. This variable is only declared if `OS_CFG_STAT_TASK_EN` is set to 1 in `OS_CFG.H`.

### **OSStatTaskCtr**

This variable contains a counter that is incremented every time the idle task infinite loop runs. This variable is only declared if `OS_CFG_STAT_TASK_EN` is set to 1 in `OS_CFG.H`.

### **OSStatTaskCtrMax**

This variable contains the maximum number of times the idle task loop runs in 0.1 second. This value is used to measure the CPU usage of the application. This variable is only declared if `OS_CFG_STAT_TASK_EN` is set to 1 in `OS_CFG.H`.

### **OSStatTaskTimeMax**

This variable contains the maximum execution time of the statistic task (in `CPU_TS` units). It is only declared if `OS_CFG_STAT_TASK_EN` is set to 1 in `OS_CFG.H`.



**OSTaskCtxSwCtr**

This variable accumulates the number of context switches performed by  $\mu$ C/OS-III.

**OSTaskQty**

The variable contains the total number of tasks created in the application.

**OSTickCtr**

This variable is incremented every time the tick task executes.

**OSTickTaskTimeMax**

This variable contains the maximum execution time of the tick task (in CPU\_TS units).

**OSTmrQty**

This variable indicates the number of timers created by the application. It is only declared if OS\_CFG\_TMR\_EN is set to 1 in OS\_CFG.H.

**OSTmrCtr**

This variable is incremented every time the timer task executes.

**OSTmrTaskTimeMax**

This variable contains the maximum execution time of the timer task (in CPU\_TS units). It is only declared if OS\_CFG\_TMR\_EN is set to 1 in OS\_CFG.H.

## 19-2 PER-TASK STATISTICS – RUN-TIME

µC/OS-III maintains statistics for each task at run-time. This information is saved in the task's `OS_TCB`.

### **.CPUUsage**

This variable keeps track of CPU usage of the task as a percentage of the total CPU usage. For example if the task's `.CPUUsage` is 20%, and the total CPU usages from `OSTaskStatCPUUsage` is 10%, this variable represents 2% of total CPU usage.

The variable is only declared when `OS_CFG_TASK_PROFILE_EN` is set to 1 in `OS_CFG.H`.

### **.CtxSwCtr**

This variable keeps track of the number of times a task is context switched to. This variable should increment. If it does not increment, the task is not running. At a minimum, the counter should at least have a value of one since a task is always created ready to run.

This variable is only declared when `OS_CFG_TASK_PROFILE_EN` is set to 1 in `OS_CFG.H`.

### **.IntDisTimeMax**

This variable keeps track of the maximum interrupt disable time of a task (in `CPU_TS` units). This variable shows how each task affects interrupt latency.

The variable is only declared when `OS_CFG_TASK_PROFILE_EN` is set to 1 in `OS_CFG.H` and defines `CPU_CFG_INT_DIS_MEAS_EN` in `CPU_CFG.H`.

### **.MsgQ.NbrEntries**

This variable indicates the number of entries currently waiting in the message queue of a task. This variable is only declared when `OS_CFG_TASK_Q_EN` is set to 1 in `OS_CFG.H`.

### **.MsgQ.NbrEntriesMax**

This variable indicates the maximum number of entries placed in the message queue of a task. This variable is only declared when `OS_CFG_TASK_Q_EN` is set to 1 in `OS_CFG.H`.

### **.MsgQ.NbrEntriesSize**

This variable indicates the maximum number of entries that a task message queue is able to accept before it is full.

This variable is only declared when `OS_CFG_TASK_Q_EN` is set to 1 in `OS_CFG.H`.

**.MsgQ.PendTime**

This variable indicates the amount of time it took for a task or an ISR to send a message to the task (in `CPU_TS` units).

The variable is only declared when `OS_CFG_TASK_PROFILE_EN` is set to 1 in `OS_CFG.H`.

**.MsgQ.PendTimeMax**

This variable indicates the maximum amount of time it took for a task or an ISR to send a message to the task (in `CPU_TS` units).

This variable is only declared when `OS_CFG_TASK_PROFILE_EN` is set to 1 in `OS_CFG.H`.

**.PendOn**

This variable indicates what a task is pending on if the task is in a pend state. Possible values are:

- 0            Nothing
- 1            Pending on an event flag group
- 2            Pending on the task's message queue
- 3            Pending on multiple objects
- 4            Pending on a mutual exclusion semaphore
- 5            Pending on a message queue
- 6            Pending on a semaphore
- 7            Pending on a task's semaphore

**.Prio**

This corresponds to the priority of the task. This might change at run time depending on whether or not the task owns a mutual exclusion semaphore, or the user changes the priority of the task by calling `OSTaskChangePrio()`.

**.SchedLockTimeMax**

This variable keeps track of the maximum time a task locks the scheduler (in `CPU_TS` units). This variable allows the application to see how each task affects task latency. The variable is declared only when `OS_CFG_TASK_PROFILE_EN` and `OS_CFG_SCHED_LOCK_TIME_MEAS_EN` are set to 1 in `OS_CFG.H`.

**.SemPendTime**

This variable indicates the amount of time it took for a task or ISR to signal the task (in CPU\_TS units).

This variable is only declared when OS\_CFG\_TASK\_PROFILE\_EN is set to 1 in OS\_CFG.H.

**.SemPendTimeMax**

This variable indicates the maximum amount of time it took for a task or an ISR to signal the task (in CPU\_TS units).

This variable is only declared when OS\_CFG\_TASK\_PROFILE\_EN is set to 1 in OS\_CFG.H.

**.State**

This variable indicates the current state of a task. The possible values are:

- 0 Ready
- 1 Delayed
- 2 Pending
- 3 Pending with Timeout
- 4 Suspended
- 5 Delayed and Suspended
- 6 Pending and Suspended
- 7 Pending, Delayed and Suspended

**.StkFree**

This variable indicates the amount of stack space (in bytes) unused by a task. This value is determined by the statistic task if OS\_CFG\_TASK\_STAT\_STK\_CHK\_EN is set to 1 in OS\_CFG.H.

**.StkUsed**

This variable indicates the maximum stack usage (in bytes) of a task. This value is determined by the statistic task if OS\_CFG\_TASK\_STAT\_STK\_CHK\_EN is set to 1 in OS\_CFG.H.

**.TickRemain**

This variable indicates the amount of time left (in clock ticks) until a task time delay expires, or the task times out waiting on a kernel object such as a semaphore, message queue, or other.

## 19-3 KERNEL OBJECT - RUN-TIME

It is possible to examine the run-time values of certain kernel objects as described below.

### SEMAPHORES

#### **.NamePtr**

This is a pointer to an ASCII string used to provide a name to the semaphore. The ASCII string can have any length as long as it is NUL terminated.

#### **.PendList.NbrEntries**

Each semaphore contains a wait list of tasks waiting for the semaphore to be signaled. The variable represents the number of entries in the wait list.

#### **.Ctr**

This variable represents the current count of the semaphore.

#### **.TS**

This variable contains the timestamp of when the semaphore was last signaled.

### MUTUAL EXCLUSION SEMAPHORES

#### **.NamePtr**

This is a pointer to an ASCII string used to provide a name to the mutual exclusion semaphore. The ASCII string can have any length as long as it is NUL terminated.

#### **.PendList.NbrEntries**

Each mutual exclusion semaphore contains a list of tasks waiting for the semaphore to be released. The variable represents the number of entries in the wait list.

#### **.OwnerOriginalPrio**

This variable holds the original priority of the task that owns the mutual exclusion semaphore.

#### **.OwnerTCBPtr->Prio**

Dereferencing the pointer to the `OS_TCB` of the mutual exclusion semaphore owner allows the application to determine whether a task priority was changed.

**.OwnerNestingCtr**

This variable indicates how many times the owner of the mutual exclusion semaphore requested the semaphore.

**.TS**

This variable contains the timestamp of when the mutual exclusion semaphore was last released.

**MESSAGE QUEUES**

**.NamePtr**

This is a pointer to an ASCII string used to provide a name to the message queue. The ASCII string can have any length, as long as it is **NUL** terminated.

**.PendList.NbrEntries**

Each message queue contains a wait list of tasks waiting for messages to be sent to the queue. The variable represents the number of entries in the wait list.

**.MsgQ.NbrEntries**

This variable represents the number of messages currently in the message queue.

**.MsgQ.NbrEntriesMax**

This variable represents the maximum number of messages ever placed in the message queue.

**.MsgQ.NbrEntriesSize**

This variable represents the maximum number of messages that can be placed in the message queue.

**EVENT FLAGS**

**.NamePtr**

This is a pointer to an ASCII string used to provide a name to the event flag group. The ASCII string can have any length, as long as it is **NUL** terminated.

**.PendList.NbrEntries**

Each event flag group contains a wait list of tasks waiting for event flags to be set or cleared. This variable represents the number of entries in the wait list.

**.Flags**

This variable contains the current value of the event flags in an event flag group.

**.TS**

This variable contains the timestamp of when the event flag group was last posted.

**MEMORY PARTITIONS**

**.NamePtr**

This is a pointer to an ASCII string that is used to provide a name to the memory partition. The ASCII string can have any length as long as it is **NUL** terminated.

**.BlkSize**

This variable contains the block size (in bytes) for the memory partition.

**.NbrMax**

This variable contains the maximum number of memory blocks belonging to the memory partition.

**.NbrFree**

This variable contains the number of memory blocks that are available from memory partition. The number of memory blocks in use is given by:

$$.NbrMax - .NbrFree$$

## 19-4 OS\_DBG.C – STATIC

OS\_DBG.C is provided in  $\mu$ C/OS-III as some debuggers are not able to read the values of `#define` constants. Specifically, OS\_DBG.C contains ROM variables initialized to `#define` constants so that users can read them with any debugger.

Below is a list of ROM variables provided in OS\_DBG.C, along with their descriptions. These variables use approximately 100 bytes of code space.

The application code can examine these variables and you do not need to access them in a critical region as they reside in code space and are therefore not changeable.

| ROM Variable | Data Type  | Value         |
|--------------|------------|---------------|
| OSDbg_DbgEn  | CPU_INT08U | OS_CFG_DBG_EN |

When 1, this variable indicates that ROM variables in OS\_DBG.C will be compiled. This value is set in OS\_CFG.H.

| ROM Variable   | Data Type  | Value             |
|----------------|------------|-------------------|
| OSDbg_ArgChkEn | CPU_INT08U | OS_CFG_ARG_CHK_EN |

When 1, this variable indicates that run-time argument checking is enabled. This means that  $\mu$ C/OS-III will check the validity of the values of arguments passed to functions. The feature is enabled in OS\_CFG.H.



---

| ROM Variable     | Data Type  | Value         |
|------------------|------------|---------------|
| OSDbg_AppHooksEn | CPU_INT08U | OS_CFG_DBG_EN |

When 1, the variable indicates whether application hooks will be available to the application programmer, and the pointers listed below are declared. This value is set in `OS_CFG.H`.

```
OS_AppTaskCreateHookPtr;
OS_AppTaskDelHookPtr;
OS_AppTaskReturnHookPtr;
OS_AppIdleTaskHookPtr;
OS_AppStatTaskHookPtr;
OS_AppTaskSwHookPtr;
OS_AppTimeTickHookPtr;
```

| ROM Variable         | Data Type  | Value      |
|----------------------|------------|------------|
| OSDbg_EndiannessTest | CPU_INT32U | 0x12345678 |

This variable allows the kernel awareness debugger or  $\mu$ C/Probe to determine the endianness of the CPU. This is easily done by looking at the lowest address in memory where this variable is saved. If the value is 0x78 then the CPU is a little endian machine. If it's 0x12, it is a big endian machine.

| ROM Variable             | Data Type  | Value                         |
|--------------------------|------------|-------------------------------|
| OSDbg_CalledFromISRChkEn | CPU_INT08U | OS_CFG_CALLED_FROM_ISR_CHK_EN |

When 1, this variable indicates that  $\mu$ C/OS-III will perform run-time checking to see if a function that is not supposed to be called from an ISR, is called from an ISR. This value is set in `OS_CFG.H`.

---

| ROM Variable | Data Type  | Value          |
|--------------|------------|----------------|
| OSDbg_FlagEn | CPU_INT08U | OS_CFG_FLAG_EN |

When 1, this variable indicates that  $\mu$ C/OS-III's event flag services are available to the application programmer. This value is set in `OS_CFG.H`.

| ROM Variable    | Data Type  | Value              |
|-----------------|------------|--------------------|
| OSDbg_FlagDelEn | CPU_INT08U | OS_CFG_FLAG_DEL_EN |

When 1, this variable indicates that the `OSFlagDel()` function is available to the application programmer. This value is set in `OS_CFG.H`.

| ROM Variable        | Data Type  | Value                   |
|---------------------|------------|-------------------------|
| OSDbg_FlagModeClrEn | CPU_INT08U | OS_CFG_FLAG_MODE_CLR_EN |

When 1, this variable indicates that cleared flags can be used instead of set flags when posting and pending on event flags. This value is set in `OS_CFG.H`.

| ROM Variable          | Data Type  | Value                     |
|-----------------------|------------|---------------------------|
| OSDbg_FlagPendAbortEn | CPU_INT08U | OS_CFG_FLAG_PEND_ABORT_EN |

When 1, this variable indicates that the `OSFlagPendAbort()` function is available to the application programmer. This value is set in `OS_CFG.H`.

| ROM Variable      | Data Type  | Value                            |
|-------------------|------------|----------------------------------|
| OSDbg_FlagGrpSize | CPU_INT16U | <code>sizeof(OS_FLAG_GRP)</code> |

This variable indicates the memory footprint (in RAM) of an event flag group (in bytes). This data type is declared in `OS.H`.

| ROM Variable    | Data Type  | Value            |
|-----------------|------------|------------------|
| OSDbg_FlagWidth | CPU_INT16U | sizeof(OS_FLAGS) |

This variable indicates the word width (in bytes) of event flags. If event flags are declared as CPU\_INT08U, this variable will be 1, if declared as a CPU\_INT16U, this variable will be 2, etc. This data type is declared in OS\_TYPE.H.

| ROM Variable   | Data Type  | Value            |
|----------------|------------|------------------|
| OSDbg_IntQSize | CPU_INT16U | sizeof(OS_INT_Q) |

This variable indicates the size of the OS\_INT\_Q data type, which is used to queue up deferred posts. The value of this variable is zero if OS\_CFG\_ISR\_POST\_DEFERRED\_EN is 0 in OS\_CFG.H.

| ROM Variable            | Data Type  | Value                       |
|-------------------------|------------|-----------------------------|
| OSDbg_ISRPostDeferredEn | CPU_INT08U | OS_CFG_ISR_POST_DEFERRED_EN |

When 1, this variable indicates that an ISR will defer posts to task-level code. This value is set in OS\_CFG.H.

| ROM Variable | Data Type  | Value         |
|--------------|------------|---------------|
| OSDbg_MemEn  | CPU_INT08U | OS_CFG_MEM_EN |

When 1, this variable indicates that  $\mu$ C/OS-III's memory management services are available to the application. This value is set in OS\_CFG.H.

| ROM Variable  | Data Type  | Value          |
|---------------|------------|----------------|
| OSDbg_MemSize | CPU_INT16U | sizeof(OS_MEM) |

This variable indicates the RAM footprint (in bytes) of a memory partition control block.

---

| ROM Variable | Data Type  | Value         |
|--------------|------------|---------------|
| OSDbg_MsgEn  | CPU_INT08U | OS_CFG_MSG_EN |

When 1, this variable indicates that the application either enabled message queues, or task message queues, or both. This value is set in `OS_CFG.H` by ORing the value of `OS_CFG_Q_EN` and `OS_CFG_TASK_Q_EN`.

| ROM Variable  | Data Type  | Value          |
|---------------|------------|----------------|
| OSDbg_MsgSize | CPU_INT16U | sizeof(OS_MSG) |

This variable indicates the RAM footprint (in bytes) of an `OS_MSG` data structure.

| ROM Variable      | Data Type  | Value               |
|-------------------|------------|---------------------|
| OSDbg_MsgPoolSize | CPU_INT16U | sizeof(OS_MSG_POOL) |

This variable indicates the RAM footprint (in bytes) of an `OS_MSG_POOL` data structure.

| ROM Variable   | Data Type  | Value            |
|----------------|------------|------------------|
| OSDbg_MsgQSize | CPU_INT16U | sizeof(OS_MSG_Q) |

This variable indicates the RAM footprint (in number of bytes) of an `OS_MSG_Q` data type.

| ROM Variable  | Data Type  | Value           |
|---------------|------------|-----------------|
| OSDbg_MutexEn | CPU_INT08U | OS_CFG_MUTEX_EN |

When 1, this variable indicates that  $\mu$ C/OS-III's mutual exclusion semaphore management services are available to the application. This value is set in `OS_CFG.H`.

---

| ROM Variable     | Data Type  | Value               |
|------------------|------------|---------------------|
| OSDbg_MutexDelEn | CPU_INT08U | OS_CFG_MUTEX_DEL_EN |

When 1, this variable indicates that the function `OSMutexDel()` is available to the application. This value is set in `OS_CFG.H`.

| ROM Variable           | Data Type  | Value                      |
|------------------------|------------|----------------------------|
| OSDbg_MutexPendAbortEn | CPU_INT08U | OS_CFG_MUTEX_PEND_ABORT_EN |

When 1, the variable indicates that the function `OSMutexPendAbort()` is available to the application. This value is set in `OS_CFG.H`.

| ROM Variable    | Data Type  | Value                         |
|-----------------|------------|-------------------------------|
| OSDbg_MutexSize | CPU_INT16U | <code>sizeof(OS_MUTEX)</code> |

This variable indicates the RAM footprint (in number of bytes) of an `OS_MUTEX` data type.

| ROM Variable       | Data Type  | Value                  |
|--------------------|------------|------------------------|
| OSDbg_ObjTypeChkEn | CPU_INT08U | OS_CFG_OBJ_TYPE_CHK_EN |

When 1, this variable indicates that  $\mu$ C/OS-III will check for valid object types at run time.  $\mu$ C/OS-III will make sure the application is accessing a semaphore if calling `OSSem???`( ) functions, accessing a message queue when calling `OSQ???`( ) functions, etc. This value is set in `OS_CFG.H`.

| ROM Variable      | Data Type  | Value                |
|-------------------|------------|----------------------|
| OSDbg_PendMultiEn | CPU_INT08U | OS_CFG_PEND_MULTI_EN |

When 1, this variable indicates that  $\mu$ C/OS-III's service to pend on multiple objects (semaphores or message queues) is available to the application. This value is set in `OS_CFG.H`.

| ROM Variable       | Data Type  | Value                |
|--------------------|------------|----------------------|
| OSDbg_PendDataSize | CPU_INT16U | sizeof(OS_PEND_DATA) |

This variable indicates the RAM footprint (in bytes) of an OS\_PEND\_DATA data type.

| ROM Variable       | Data Type  | Value                |
|--------------------|------------|----------------------|
| OSDbg_PendListSize | CPU_INT16U | sizeof(OS_PEND_LIST) |

This variable indicates the RAM footprint (in bytes) of an OS\_PEND\_LIST data type.

| ROM Variable      | Data Type  | Value               |
|-------------------|------------|---------------------|
| OSDbg_PendObjSize | CPU_INT16U | sizeof(OS_PEND_OBJ) |

This variable indicates the RAM footprint (in bytes) of an OS\_PEND\_OBJ data type.

| ROM Variable  | Data Type  | Value           |
|---------------|------------|-----------------|
| OSDbg_PrioMax | CPU_INT16U | OS_CFG_PRIO_MAX |

This variable indicates the maximum number of priorities that the application will support.

| ROM Variable  | Data Type  | Value          |
|---------------|------------|----------------|
| OSDbg_PtrSize | CPU_INT16U | sizeof(void *) |

This variable indicates the size (in bytes) of a pointer.

| ROM Variable | Data Type  | Value       |
|--------------|------------|-------------|
| OSDbg_QEn    | CPU_INT08U | OS_CFG_Q_EN |

When 1, this variable indicates that  $\mu$ C/OS-III's message queue services are available to the application. This value is set in OS\_CFG.H.

---

| ROM Variable | Data Type  | Value           |
|--------------|------------|-----------------|
| OSDbg_QDelEn | CPU_INT08U | OS_CFG_Q_DEL_EN |

When 1, this variable indicates that the function `OSQDel()` is available to the application. This value is set in `OS_CFG.H`.

| ROM Variable   | Data Type  | Value             |
|----------------|------------|-------------------|
| OSDbg_QFlushEn | CPU_INT08U | OS_CFG_Q_FLUSH_EN |

When 1, this variable indicates that the function `OSQFlush()` is available to the application. This value is set in `OS_CFG.H`.

| ROM Variable       | Data Type  | Value                  |
|--------------------|------------|------------------------|
| OSDbg_QPendAbortEn | CPU_INT08U | OS_CFG_Q_PEND_ABORT_EN |

When 1, this variable indicates that the function `OSQPendAbort()` is available to the application. This value is set in `OS_CFG.H`.

| ROM Variable | Data Type  | Value |
|--------------|------------|-------|
| OSDbg_QSize  | CPU_INT16U |       |

This variable indicates the RAM footprint (in number of bytes) of an `OS_Q` data type.

| ROM Variable            | Data Type  | Value                 |
|-------------------------|------------|-----------------------|
| OSDbg_SchedRoundRobinEn | CPU_INT08U | OS_CFG_ROUND_ROBIN_EN |

When 1, this variable indicates that the  $\mu$ C/OS-III round robin scheduling feature is available to the application. This value is set in `OS_CFG.H`.

---

| ROM Variable | Data Type  | Value         |
|--------------|------------|---------------|
| OSDbg_SemEn  | CPU_INT08U | OS_CFG_SEM_EN |

When 1, this variable indicates that  $\mu$ C/OS-III's semaphore management services are available to the application. This value is set in `OS_CFG.H`.

| ROM Variable   | Data Type  | Value             |
|----------------|------------|-------------------|
| OSDbg_SemDelEn | CPU_INT08U | OS_CFG_SEM_DEL_EN |

When 1, this variable indicates that the function `OSSemDel()` is available to the application. This value is set in `OS_CFG.H`.

| ROM Variable         | Data Type  | Value                    |
|----------------------|------------|--------------------------|
| OSDbg_SemPendAbortEn | CPU_INT08U | OS_CFG_SEM_PEND_ABORT_EN |

When 1, this variable indicates that the function `OSSemPendAbort()` is available to the application. This value is set in `OS_CFG.H`.

| ROM Variable   | Data Type  | Value             |
|----------------|------------|-------------------|
| OSDbg_SemSetEn | CPU_INT08U | OS_CFG_SEM_SET_EN |

When 1, this variable indicates that the function `OSSemSet()` is available to the application. This value is set in `OS_CFG.H`.

| ROM Variable  | Data Type  | Value                            |
|---------------|------------|----------------------------------|
| OSDbg_RdyList | CPU_INT16U | <code>sizeof(OS_RDY_LIST)</code> |

This variable indicates the RAM footprint (in bytes) of an `OS_RDY_LIST` data type.



---

| <b>ROM Variable</b> | <b>Data Type</b> | <b>Value</b>      |
|---------------------|------------------|-------------------|
| OSDbg_RdyListSize   | CPU_INT32U       | sizeof(OSRdyList) |

This variable indicates the RAM footprint (in bytes) of the ready list.

| <b>ROM Variable</b> | <b>Data Type</b> | <b>Value</b>    |
|---------------------|------------------|-----------------|
| OSDbg_StkWidth      | CPU_INT08U       | sizeof(CPU_STK) |

This variable indicates the word size of a stack entry (in bytes). If a stack entry is declared as `CPU_INT08U`, this value will be 1, if a stack entry is declared as `CPU_INT16U`, the value will be 2, etc.

| <b>ROM Variable</b> | <b>Data Type</b> | <b>Value</b>        |
|---------------------|------------------|---------------------|
| OSDbg_StatTaskEn    | CPU_INT08U       | OS_CFG_STAT_TASK_EN |

When 1, this variable indicates that  $\mu$ C/OS-III's statistic task is enabled. This value is set in `OS_CFG.H`.

| <b>ROM Variable</b>    | <b>Data Type</b> | <b>Value</b>                |
|------------------------|------------------|-----------------------------|
| OSDbg_StatTaskStkChkEn | CPU_INT08U       | OS_CFG_STAT_TASK_STK_CHK_EN |

When 1, this variable indicates that  $\mu$ C/OS-III will perform run-time stack checking by walking the stack of each task to determine the usage of each. This value is set in `OS_CFG.H`.

| <b>ROM Variable</b>    | <b>Data Type</b> | <b>Value</b>               |
|------------------------|------------------|----------------------------|
| OSDbg_TaskChangePrioEn | CPU_INT08U       | OS_CFG_TASK_CHANGE_PRIO_EN |

When 1, this variable indicates that the function `OSTaskChangePrio()` is available to the application. This value is set in `OS_CFG.H`.

| ROM Variable    | Data Type  | Value              |
|-----------------|------------|--------------------|
| OSDbg_TaskDelEn | CPU_INT08U | OS_CFG_TASK_DEL_EN |

When 1, this variable indicates that the function `OSTaskDel()` is available to the application. This value is set in `OS_CFG.H`.

| ROM Variable  | Data Type  | Value            |
|---------------|------------|------------------|
| OSDbg_TaskQEn | CPU_INT08U | OS_CFG_TASK_Q_EN |

When 1, this variable indicates that `OSTaskQ???` services are available to the application. This value is set in `OS_CFG.H`.

| ROM Variable           | Data Type  | Value                       |
|------------------------|------------|-----------------------------|
| OSDbg_TaskQPendAbortEn | CPU_INT08U | OS_CFG_TASK_Q_PEND_ABORT_EN |

When 1, this variable indicates that the function `OSTaskQPendAbort()` is available to the application. This value is set in `OS_CFG.H`.

| ROM Variable        | Data Type  | Value                  |
|---------------------|------------|------------------------|
| OSDbg_TaskProfileEn | CPU_INT08U | OS_CFG_TASK_PROFILE_EN |

When 1, this variable indicates that task profiling is enabled, and that  $\mu\text{C}/\text{OS-III}$  will perform run-time performance measurements on a per-task basis. Specifically, when 1,  $\mu\text{C}/\text{OS-III}$  will keep track of how many context switches each task makes, how long a task disables interrupts, how long a task locks the scheduler, and more. This value is set in `OS_CFG.H`.

| ROM Variable         | Data Type  | Value                    |
|----------------------|------------|--------------------------|
| OSDbg_TaskRegTblSize | CPU_INT16U | OS_CFG_TASK_REG_TBL_SIZE |

This variable indicates how many entries each task register table can accept.

---

| ROM Variable             | Data Type  | Value                         |
|--------------------------|------------|-------------------------------|
| OSDbg_TaskSemPendAbortEn | CPU_INT08U | OS_CFG_TASK_SEM_PEND_ABORT_EN |

When 1, this variable indicates that the function `OSTaskSemPendAbort()` is available to the application. This value is set in `OS_CFG.H`.

| ROM Variable        | Data Type  | Value                  |
|---------------------|------------|------------------------|
| OSDbg_TaskSuspendEn | CPU_INT08U | OS_CFG_TASK_SUSPEND_EN |

When 1, this variable indicates that the function `OSTaskSuspend()` is available to the application. This value is set in `OS_CFG.H`.

| ROM Variable  | Data Type  | Value                       |
|---------------|------------|-----------------------------|
| OSDbg_TCBSize | CPU_INT16U | <code>sizeof(OS_TCB)</code> |

This variable indicates the RAM footprint (in bytes) of an `OS_TCB` data structure.

| ROM Variable        | Data Type  | Value                              |
|---------------------|------------|------------------------------------|
| OSDbg_TickSpokeSize | CPU_INT16U | <code>sizeof(OS_TICK_SPOKE)</code> |

This variable indicates the RAM footprint (in bytes) of an `OS_TICK_SPOKE` data structure.

| ROM Variable        | Data Type  | Value                   |
|---------------------|------------|-------------------------|
| OSDbg_TimeDlyHMSMEn | CPU_INT08U | OS_CFG_TIME_DLY_HMSM_EN |

When 1, this variable indicates that the function `OSTimeDlyHMSM()` is available to the application. This value is set in `OS_CFG.H`.

---

| ROM Variable          | Data Type  | Value                     |
|-----------------------|------------|---------------------------|
| OSDbg_TimeDlyResumeEn | CPU_INT08U | OS_CFG_TIME_DLY_RESUME_EN |

When 1, this variable indicates that the function `OSTimeDlyResume()` is available to the application. This value is set in `OS_CFG.H`.

| ROM Variable | Data Type  | Value         |
|--------------|------------|---------------|
| OSDbg_TmrEn  | CPU_INT08U | OS_CFG_TMR_EN |

When 1, this variable indicates that `OSTmr???` services are available to the application. This value is set in `OS_CFG.H`.

| ROM Variable   | Data Type  | Value             |
|----------------|------------|-------------------|
| OSDbg_TmrDelEn | CPU_INT08U | OS_CFG_TMR_DEL_EN |

When 1, this variable indicates that the function `OSTmrDel()` is available to the application. This value is set in `OS_CFG.H`.

| ROM Variable  | Data Type  | Value                       |
|---------------|------------|-----------------------------|
| OSDbg_TmrSize | CPU_INT16U | <code>sizeof(OS_TMR)</code> |

This variable indicates the RAM footprint (in bytes) of an `OS_TMR` data structure.

| ROM Variable       | Data Type  | Value                             |
|--------------------|------------|-----------------------------------|
| OSDbg_TmrSpokeSize | CPU_INT16U | <code>sizeof(OS_TMR_SPOKE)</code> |

This variable indicates the RAM footprint (in bytes) of an `OS_TMR_SPOKE` data structure.

---

| ROM Variable     | Data Type  | Value      |
|------------------|------------|------------|
| OSDbg_VersionNbr | CPU_INT16U | OS_VERSION |

This variable indicates the current version of  $\mu$ C/OS-III multiplied by 1000. For example version 3.00.4 will show as 3004.ZZ

| ROM Variable   | Data Type  | Value                     |
|----------------|------------|---------------------------|
| OSDbg_DataSize | CPU_INT32U | Size of all RAM variables |

This variable indicates the RAM footprint (in bytes) of the internal  $\mu$ C/OS-III variables for the current configuration.

## 19-5 OS\_CFG\_APP.C – STATIC

As with `OS_DBG.C`, `OS_CFG_APP.C` defines a number of ROM variables. These variables, however, reflect the run-time configuration of an application. Specifically, the user will be able to know the RAM footprint (in bytes) of  $\mu$ C/OS-III task stacks, the message pool, and more.

Below is a list of ROM variables provided in `OS_APP_CFG.C`, along with their descriptions. These variables represent approximately 100 bytes of code space.

Application code can examine these variables and the application does not need to access them in a critical region since they reside in code space and are therefore not changeable.

| ROM Variable             | Data Type  | Value                     |
|--------------------------|------------|---------------------------|
| OSCfg_IdleTaskStkSizeRAM | CPU_INT32U | sizeof(OSCfg_IdleTaskStk) |

This variable indicates the RAM footprint (in bytes) of the  $\mu$ C/OS-III idle task stack.

| ROM Variable      | Data Type  | Value              |
|-------------------|------------|--------------------|
| OSCfg_IntQSizeRAM | CPU_INT32U | sizeof(OSCfg_IntQ) |

This variable indicates the RAM footprint (in bytes) of the  $\mu$ C/OS-III interrupt handler task queue.

| ROM Variable             | Data Type  | Value                     |
|--------------------------|------------|---------------------------|
| OSCfg_IntQTaskStkSizeRAM | CPU_INT32U | sizeof(OSCfg_IntQTaskStk) |

This variable indicates the RAM footprint (in bytes) of the  $\mu$ C/OS-III interrupt queue handler task stack.

| ROM Variable        | Data Type  | Value                |
|---------------------|------------|----------------------|
| OSCfg_ISRStkSizeRAM | CPU_INT32U | sizeof(OSCfg_ISRStk) |

This variable indicates the RAM footprint (in bytes) of the dedicated Interrupt Service Routine (ISR) stack.

| ROM Variable         | Data Type  | Value                 |
|----------------------|------------|-----------------------|
| OSCfg_MsgPoolSizeRAM | CPU_INT32U | sizeof(OSCfg_MsgPool) |

This variable indicates the RAM footprint (in bytes) of the message pool.

| ROM Variable             | Data Type  | Value                     |
|--------------------------|------------|---------------------------|
| OSCfg_StatTaskStkSizeRAM | CPU_INT32U | sizeof(OSCfg_StatTaskStk) |

This variable indicates the RAM footprint (in bytes) of the  $\mu$ C/OS-III statistic task stack.

| ROM Variable             | Data Type  | Value                     |
|--------------------------|------------|---------------------------|
| OSCfg_TickTaskStkSizeRAM | CPU_INT32U | sizeof(OSCfg_TickTaskStk) |

This variable indicates the RAM footprint (in bytes) of the  $\mu$ C/OS-III tick task stack.

---

| <b>ROM Variable</b>    | <b>Data Type</b> | <b>Value</b>            |
|------------------------|------------------|-------------------------|
| OSCfg_TickWheelSizeRAM | CPU_INT32U       | sizeof(OSCfg_TickWheel) |

This variable indicates the RAM footprint (in bytes) of the tick wheel.

| <b>ROM Variable</b>   | <b>Data Type</b> | <b>Value</b>           |
|-----------------------|------------------|------------------------|
| OSCfg_TmrWheelSizeRAM | CPU_INT32U       | sizeof(OSCfg_TmrWheel) |

This variable indicates the RAM footprint (in bytes) of the timer wheel.

| <b>ROM Variable</b> | <b>Data Type</b> | <b>Value</b>                   |
|---------------------|------------------|--------------------------------|
| OSCfg_DataSizeRAM   | CPU_INT32U       | Total of all configuration RAM |

This variable indicates the RAM footprint (in bytes) of all of the configuration variables declared in `OS_CFG_APP.C`.

## 19-6 SUMMARY

This chapter presented a number of variables that can be read by a debugger and/or  $\mu$ C/Probe.

These variables provide run-time and compile-time (static) information regarding  $\mu$ C/OS-III-based applications. The  $\mu$ C/OS-III variables allow users to monitor RAM footprint, task stack usage, context switches, CPU usage, the execution time of many operations, and more.

The application must never change (i.e., write to) any of these variables.





# A

## μC/OS-III API Reference Manual

This chapter provides a reference to μC/OS-III services. Each of the user-accessible kernel services is presented in alphabetical order. The following information is provided for each entry:

- A brief description of the service
- The function prototype
- The filename of the source code
- The **#define** constant required to enable code for the service
- A description of the arguments passed to the function
- A description of returned value(s)
- Specific notes and warnings regarding use of the service
- One or two examples of how to use the function

Many functions return error codes. These error codes should be checked by the application to ensure that the μC/OS-III function performed its operation as expected.

The next few pages summarizes most of the services provided by μC/OS-III. The function calls in bold are commonly used.

## A-1 TASK MANAGEMENT

|                      |   |  |  |
|----------------------|---|--|--|
| void                 |   |  |  |
| OSTaskChangePrio     | (OS_TCB<br>OS_PRIO<br>OS_ERR  | *p_tcb,<br>prio,<br>*p_err);   |  |
| void                 |   |  | Values for "opt":<br>OS_OPT_TASK_NONE<br>OS_OPT_TASK_STK_CHK<br>OS_OPT_TASK_STK_CLR<br>OS_OPT_TASK_SAVE_FP |
| <b>OSTaskCreate</b>  | (OS_TCB<br>CPU_CHAR<br>OS_TASK_PTR<br>void<br>OS_PRIO<br>CPU_STK<br>CPU_STK_SIZE<br>CPU_STK_SIZE<br>OS_MSG_QTY<br>OS_TICK<br>void<br>OS_OPT<br>OS_ERR | *p_tcb,<br>*p_name,<br>*p_task,<br>*p_arg,<br>prio,<br>*p_stk_base,<br>stk_limit,<br>stk_size,<br>q_size,<br>time_quanta,<br>*p_ext,<br>opt,<br>*p_err); |  |
| void                 |   |  |  |
| OSTaskDel            | (OS_TCB<br>OS_ERR   | *p_tcb,<br>*p_err);  |  |
| OS_REG               |   |  |  |
| <b>OSTaskRegGet</b>  | (OS_TCB<br>OS_REG_ID<br>OS_ERR  | *p_tcb,<br>id,<br>*p_err);   |  |
| void                 |   |  |  |
| <b>OSTaskRegSet</b>  | (OS_TCB<br>OS_REG_ID<br>OS_REG<br>OS_ERR  | *p_tcb,<br>id,<br>value,<br>*p_err);   |  |
| void                 |   |  |  |
| <b>OSTaskResume</b>  | (OS_TCB<br>OS_ERR   | *p_tcb,<br>*p_err);  |  |
| void                 |   |  |  |
| <b>OSTaskSuspend</b> | (OS_TCB<br>OS_ERR   | *p_tcb,<br>*p_err);  |  |
| void                 |   |  |  |
| OSTaskStkChk         | (OS_TCB<br>CPU_STK_SIZE<br>CPU_STK_SIZE<br>OS_ERR   | *p_tcb,<br>*p_free,<br>*p_used,<br>*p_err);  |  |

```
void  
OSTaskTimeQuantaSet (OS_TCB    *p_tcb,  
                      OS_TICK    time_quanta,  
                      OS_ERR      *p_err);
```

## A-2 TIME MANAGEMENT

|  |   |
|--|---|
| <pre>void <b>OSTimeDly</b>    (OS_TICK    dly,               OS_OPT     opt,               OS_ERR    *p_err);</pre>  |   |
| <pre>void <b>OSTimeDlyHMSM</b> (CPU_INT16U  hours,                 CPU_INT16U  minutes,                 CPU_INT16U  seconds,                 CPU_INT32U  milli,                 OS_OPT     opt,                 OS_ERR    *p_err);</pre> | <p>Values for "opt":</p> <pre>OS_OPT_TIME_HMSM_STRICT OS_OPT_TIME_HMSM_NON_STRICT</pre> |
| <pre>void OSTimeDlyResume (OS_TCB    *p_tcb,                 OS_ERR    *p_err);</pre>  |   |
| <pre>OS_TICK <b>OSTimeGet</b>    (OS_ERR    *p_err);</pre>   |   |
| <pre>void <b>OSTimeSet</b>    (OS_TICK    ticks,               OS_ERR    *p_err);</pre>  |   |

## A-3 MUTUAL EXCLUSION SEMAPHORES – RESOURCE MANAGEMENT

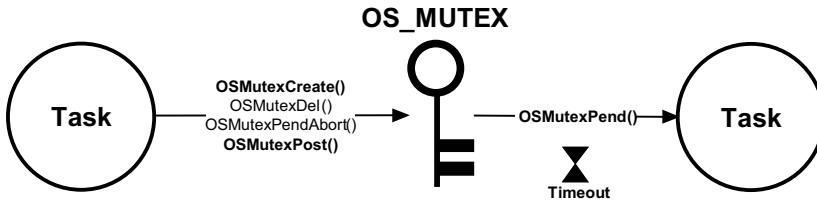

|   |  |
|---|--|
| <pre>void <b>OSMutexCreate</b> (OS_MUTEX  *p_mutex,                 CPU_CHAR  *p_name,                 OS_ERR    *p_err);</pre>   |  |
| <pre>void OSMutexDel    (OS_MUTEX  *p_mutex,                 OS_OPT    opt,                 OS_ERR    *p_err);</pre>  | Values for "opt":<br>OS_OPT_DEL_NO_PEND<br>OS_OPT_DEL_ALWAYS   |
| <pre>void <b>OSMutexPend</b> (OS_MUTEX  *p_mutex,                 OS_TICK    timeout,                 OS_OPT    opt,                 CPU_TS     *p_ts,                 OS_ERR    *p_err);</pre> | Values for "opt":<br>OS_OPT_PEND_BLOCKING<br>OS_OPT_PEND_NON_BLOCKING                                |
| <pre>OS_OBJ_QTY OSMutexPendAbort (OS_MUTEX *p_mutex,                   OS_OPT    opt,                   OS_ERR    *p_err);</pre>  | Values for "opt":<br>OS_OPT_PEND_ABORT_1<br>OS_OPT_PEND_ABORT_ALL<br>OS_OPT_POST_NO_SCHED (additive) |
| <pre>void <b>OSMutexPost</b> (OS_MUTEX  *p_mutex,                 OS_OPT    opt,                 OS_ERR    *p_err);</pre>   | Values for "opt":<br>OS_OPT_POST_NONE<br>OS_OPT_POST_NO_SCHED  |

## A-4 EVENT FLAGS – SYNCHRONIZATION

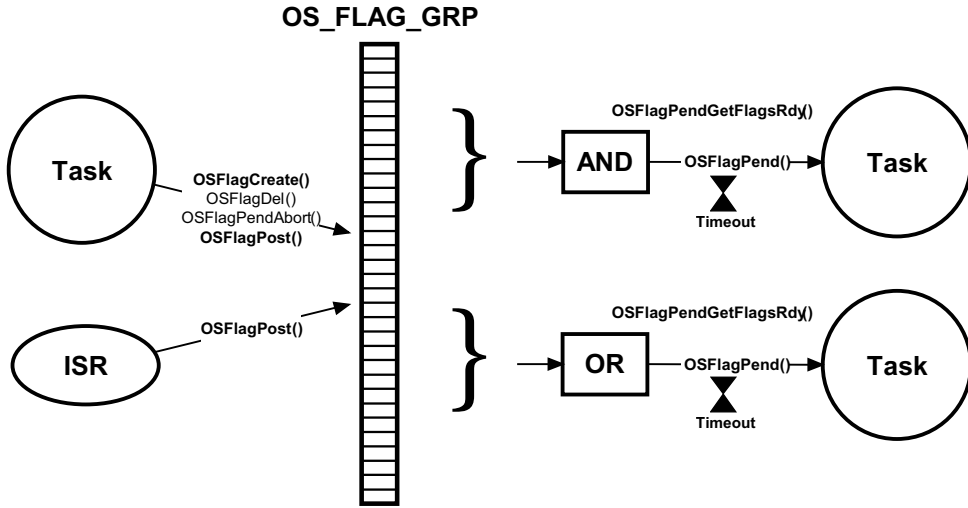

|  |  |   |
|--|--|---|
| void<br><b>OSFlagCreate</b>              | (OS_FLAG_GRP *p_grp,<br>CPU_CHAR *p_name,<br>OS_FLAGS flags,<br>OS_ERR *p_err);                                |   |
| OS_OBJ_QTY<br>OSFlagDel                  | (OS_FLAG_GRP *p_grp,<br>OS_OPT opt,<br>OS_ERR *p_err);   | Values for "opt":<br>OS_OPT_DEL_NO_PEND<br>OS_OPT_DEL_ALWAYS  |
| OS_FLAGS<br><b>OSFlagPend</b>            | (OS_FLAG_GRP *p_grp,<br>OS_FLAGS flags,<br>OS_TICK timeout,<br>OS_OPT opt,<br>CPU_TS *p_ts,<br>OS_ERR *p_err); | Values for "opt":<br>OS_OPT_PEND_FLAG_CLR_ALL<br>OS_OPT_PEND_FLAG_CLR_ANY<br>OS_OPT_PEND_FLAG_SET_ALL<br>OS_OPT_PEND_FLAG_SET_ANY |
| OS_OBJ_QTY<br>OSFlagPendAbort            | (OS_FLAG_GRP *p_grp,<br>OS_OPT opt,<br>OS_ERR *p_err);   | Values for "opt":<br>OS_OPT_PEND_ABORT_1<br>OS_OPT_PEND_ABORT_ALL<br>OS_OPT_POST_NO_SCHED (additive)                              |
| OS_FLAGS<br><b>OSFlagPendGetFlagsRdy</b> | (OS_ERR *p_err);   |   |
| OS_FLAGS<br><b>OSFlagPost</b>            | (OS_FLAG_GRP *p_grp,<br>OS_FLAGS flags,<br>OS_OPT opt,<br>OS_ERR *p_err);                                      | Values for "opt":<br>OS_OPT_POST_FLAG_SET<br>OS_OPT_POST_FLAG_CLR   |

## A-5 SEMAPHORES – SYNCHRONIZATION

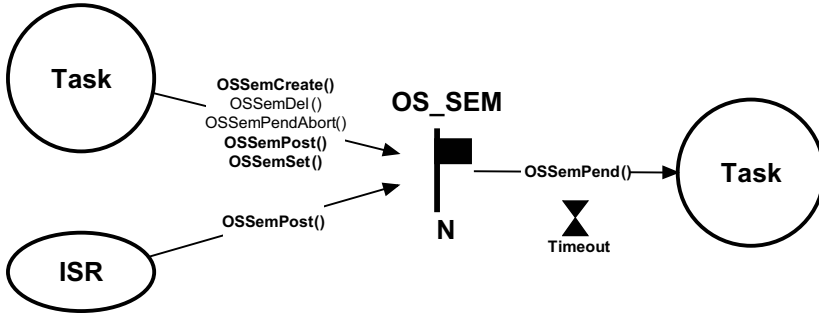

|  |   |
|--|---|
| <pre>void OS_SemCreate (OS_SEM      *p_sem,               CPU_CHAR    *p_name,               OS_SEM_CTR  cnt,               OS_ERR      *p_err);</pre>                                       |   |
| <pre>OS_OBJ_QTY OS_SemDel    (OS_SEM      *p_sem,               OS_OPT      opt,               OS_ERR      *p_err);</pre>  | Values for "opt":<br><code>OS_OPT_DEL_NO_PEND</code><br><code>OS_OPT_DEL_ALWAYS</code>  |
| <pre>OS_SEM_CTR OS_SemPend  (OS_SEM      *p_sem,               OS_TICK     timeout,               OS_OPT      opt,               CPU_TS      *p_ts,               OS_ERR      *p_err);</pre> | Values for "opt":<br><code>OS_OPT_PEND_BLOCKING</code><br><code>OS_OPT_PEND_NON_BLOCKING</code>   |
| <pre>OS_OBJ_QTY OS_SemPendAbort (OS_SEM    *p_sem,                  OS_OPT     opt,                  OS_ERR     *p_err);</pre>   | Values for "opt":<br><code>OS_OPT_PEND_ABORT_1</code><br><code>OS_OPT_PEND_ABORT_ALL</code><br><code>OS_OPT_POST_NO_SCHED</code> (additive) |
| <pre>void OS_SemPost   (OS_SEM      *p_sem,               OS_OPT      opt,               OS_ERR      *p_err);</pre>  | Values for "opt":<br><code>OS_OPT_POST_1</code><br><code>OS_OPT_POST_ALL</code><br><code>OS_OPT_POST_NO_SCHED</code> (additive)             |
| <pre>void OS_SemSet    (OS_SEM      *p_sem,               OS_SEM_CTR  cnt,               OS_ERR      *p_err);</pre>  |   |

## A-6 TASK SEMAPHORES – SYNCHRONIZATION

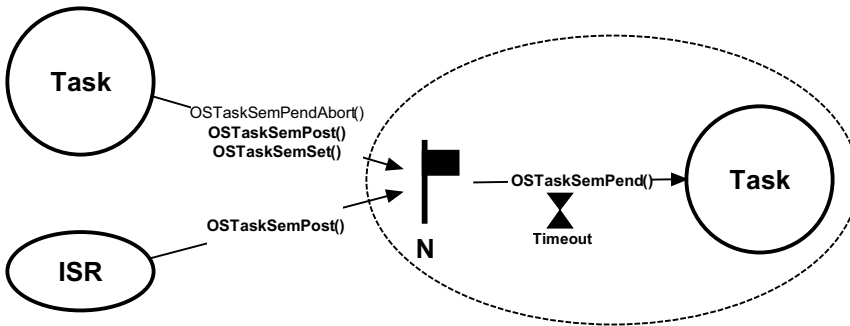

|                           |            |          |  |                          |
|---------------------------|------------|----------|--|--------------------------|
| OS_SEM_CTR                |            |          |  | Values for "opt":        |
| <b>OSTaskSemPend</b>      | (OS_TICK   | timeout, |  | OS_OPT_PEND_BLOCKING     |
|                           | OS_OPT     | opt,     |  | OS_OPT_PEND_NON_BLOCKING |
|                           | CPU_TS     | *p_ts,   |  |                          |
|                           | OS_ERR     | *p_err); |  |                          |
| CPU_BOOLEAN               |            |          |  | Values for "opt":        |
| <b>OSTaskSemPendAbort</b> | (OS_TCB    | *p_tcb,  |  | OS_OPT_POST_NONE         |
|                           | OS_OPT     | opt,     |  | OS_OPT_POST_NO_SCHED     |
|                           | OS_ERR     | *p_err); |  |                          |
| OS_SEM_CTR                |            |          |  | Values for "opt":        |
| <b>OSTaskSemPost</b>      | (OS_TCB    | *p_tcb,  |  | OS_OPT_POST_NONE         |
|                           | OS_OPT     | opt,     |  | OS_OPT_POST_NO_SCHED     |
|                           | OS_ERR     | *p_err); |  |                          |
| OS_SEM_CTR                |            |          |  |                          |
| <b>OSTaskSemSet</b>       | (OS_TCB    | *p_tcb,  |  |                          |
|                           | OS_SEM_CTR | cnt,     |  |                          |
|                           | OS_ERR     | *p_err); |  |                          |



## A-7 MESSAGE QUEUES – MESSAGE PASSING

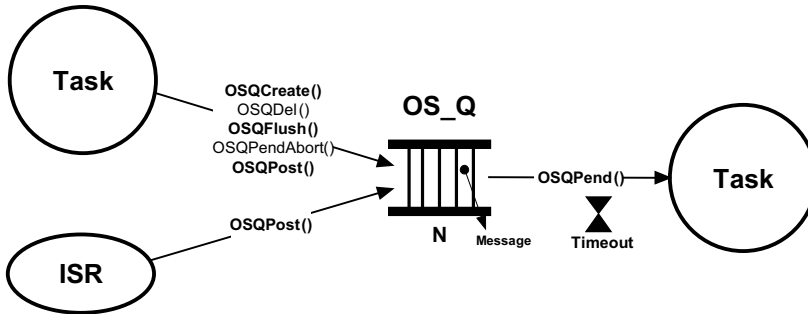

|   |   |
|---|---|
| <pre>void <b>OSQCreate</b> (OS_Q      *p_q,             CPU_CHAR  *p_name,             OS_MSG_QTY max_qty,             OS_ERR    *p_err);</pre>   |   |
| <pre>OS_OBJ_QTY, OSQDel (OS_Q      *p_q,         OS_OPT    opt,         OS_ERR    *p_err);</pre>  | Values for "opt":<br>OS_OPT_DEL_NO_PEND<br>OS_OPT_DEL_ALWAYS  |
| <pre>OS_MSG_QTY OSQFlush (OS_Q      *p_q,            OS_ERR    *p_err);</pre>   |   |
| <pre>void * <b>OSQPend</b> (OS_Q      *p_q,            OS_TICK    timeout,            OS_OPT    opt,            OS_MSG_SIZE *p_msg_size,            CPU_TS     *p_ts,            OS_ERR    *p_err);</pre> | Values for "opt":<br>OS_OPT_PEND_BLOCKING<br>OS_OPT_PEND_NON_BLOCKING   |
| <pre>OS_OBJ_QTY OSQPendAbort (OS_Q      *p_q,               OS_OPT    opt,               OS_ERR    *p_err);</pre>   | Values for "opt":<br>OS_OPT_PEND_ABORT_1<br>OS_OPT_PEND_ABORT_ALL<br>OS_OPT_POST_NO_SCHED (additive)            |
| <pre>void <b>OSQPost</b> (OS_Q      *p_q,            void      *p_void,            OS_MSG_SIZE msg_size,            OS_OPT    opt,            OS_ERR    *p_err);</pre>                                    | Values for "opt":<br>OS_OPT_POST_ALL<br>OS_OPT_POST_FIFO<br>OS_OPT_POST_LIFO<br>OS_OPT_POST_NO_SCHED (additive) |

## A-8 TASK MESSAGE QUEUES - MESSAGE PASSING

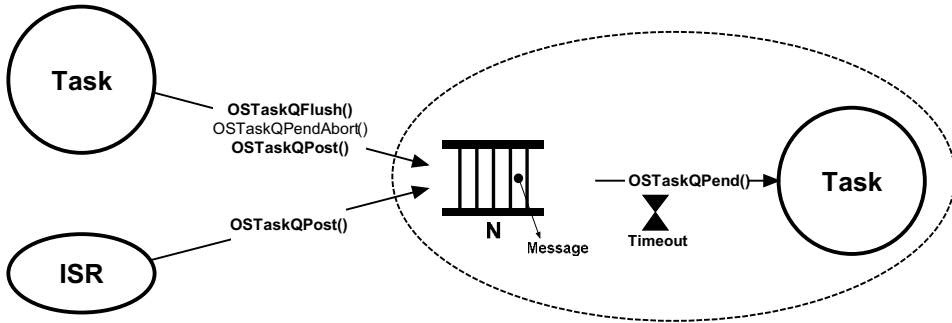

|  |  |
|--|--|
| <pre>OS_MSG_QTY OSTaskQFlush (OS_TCB    *p_tcb,               OS_ERR    *p_err);</pre>   |  |
| <pre>void * OSTaskQPend (OS_TICK    timeout,             OS_OPT      opt,             OS_MSG_SIZE *p_msg_size,             CPU_TS      *p_ts,             OS_ERR      *p_err);</pre> | <p>Values for "opt":</p> <ul style="list-style-type: none"> <li>OS_OPT_PEND_BLOCKING</li> <li>OS_OPT_PEND_NON_BLOCKING</li> </ul>                              |
| <pre>CPU_BOOLEAN OSTaskQPendAbort (OS_TCB    *p_tcb,                  OS_OPT      opt,                  OS_ERR      *p_err);</pre>   | <p>Values for "opt":</p> <ul style="list-style-type: none"> <li>OS_OPT_POST_NONE</li> <li>OS_OPT_POST_NO_SCHED</li> </ul>                                      |
| <pre>void OSTaskQPost (OS_TCB    *p_tcb,             void        *p_void,             OS_MSG_SIZE msg_size,             OS_OPT      opt,             OS_ERR      *p_err);</pre>      | <p>Values for "opt":</p> <ul style="list-style-type: none"> <li>OS_OPT_POST_FIFO</li> <li>OS_OPT_POST_LIFO</li> <li>OS_OPT_POST_NO_SCHED (additive)</li> </ul> |

## A-9 PENDING ON MULTIPLE OBJECTS

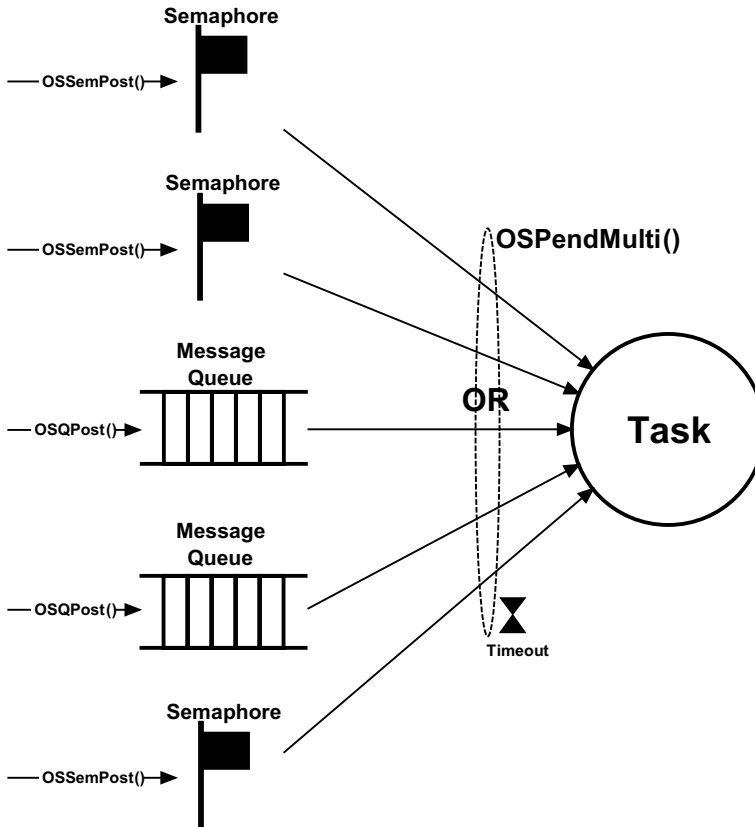

OS\_OBJ\_QTY

```

OSPendMulti (OS_PEND_DATA *p_pend_data_tbl,
              OS_OBJ_QTY   tbl_size,
              OS_TICK      timeout,
              OS_OPT        opt,
              OS_ERR        *p_err);
    
```

Values for "opt":

```

    OS_OPT_PEND_BLOCKING
    OS_OPT_PEND_NON_BLOCKING
    
```

## A-10 TIMERS

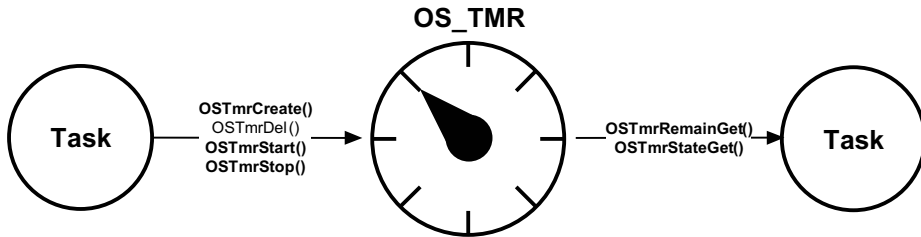

|                       |  |   |  |
|-----------------------|--|---|--|
| void                  |  |   | Values for "opt":                          |
| <b>OSTmrCreate</b>    | (OS_TMR<br>CPU_CHAR<br>OS_TICK<br>OS_TICK<br>OS_OPT<br>OS_TMR_CALLBACK_PTR<br>void<br>OS_ERR | (*p_tmr,<br>*p_name,<br>dly,<br>period,<br>opt,<br>*p_callback,<br>*p_callback_arg,<br>*p_err); | OS_OPT_TMR_ONE_SHOT<br>OS_OPT_TMR_PERIODIC |
| CPU_BOOLEAN           |  |   |  |
| <b>OSTmrDel</b>       | (OS_TMR<br>OS_ERR  | (*p_tmr,<br>*p_err);  |  |
| OS_TICK               |  |   |  |
| <b>OSTmrRemainGet</b> | (OS_TMR<br>OS_ERR  | (*p_tmr,<br>*p_err);  |  |
| OS_STATE              |  |   |  |
| <b>OSTmrStateGet</b>  | (OS_TMR<br>OS_ERR  | (*p_tmr,<br>*p_err);  |  |
| CPU_BOOLEAN           |  |   |  |
| <b>OSTmrStart</b>     | (OS_TMR<br>OS_ERR  | (*p_tmr,<br>*p_err);  |  |
| CPU_BOOLEAN           |  |   |  |
| <b>OSTmrStop</b>      | (OS_TMR<br>OS_OPT<br>void<br>OS_ERR  | (*p_tmr,<br>opt,<br>*p_callback_arg,<br>*p_err);  |  |

## A-11 FIXED-SIZE MEMORY PARTITIONS – MEMORY MANAGEMENT

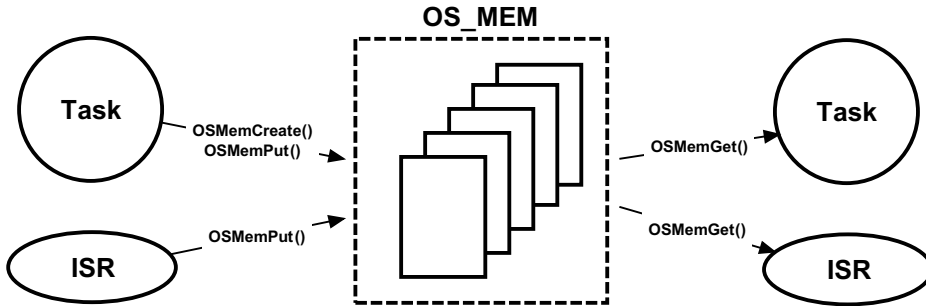

```
void  
OSMemCreate (OS_MEM    *p_mem,  
              CPU_CHAR  *p_name,  
              void       *p_addr,  
              OS_MEM_QTY n_blks,  
              OS_MEM_SIZE blk_size,  
              OS_ERR     *p_err);
```

---

```
void *  
OSMemGet   (OS_MEM    *p_mem,  
              OS_ERR     *p_err);
```

---

```
void  
OSMemPut   (OS_MEM    *p_mem,  
              void       *p_blk,  
              OS_ERR     *p_err);
```

# OSCtxSw ()

```
void OScTxSw (void)
```

| File         | Called from | Code enabled by |
|--------------|-------------|-----------------|
| OS_CPU_A.ASM | OSSched()   | N/A             |

OSCtxSw() is called from the macro OS\_TASK\_SW(), which in turn is called from OSSched() to perform a task-level context switch. Interrupts are disabled when OScTxSw() is called.

Prior to calling OScTxSw(), OSSched() sets OSTCBCurPtr to point at the OS\_TCB of the task that is being switched out, and OSTCBHighRdyPtr to point at the OS\_TCB of the task being switched in.

## Arguments

None

## Returned Values

None

## Notes/Warnings

None

## Example

The pseudocode for OScTxSw() follows:

```
void OScTxSw (void)
{
    Save all CPU registers;                (1)
    OSTCBCurPtr->StkPtr = SP;              (2)
    OSTaskSwHook();                        (3)
    OSPrioCur = OSPrioHighRdy;           (4)
    OSTCBCurPtr = OSTCBHighRdyPtr;        (5)
    SP = OSTCBHighRdyPtr->StkPtr;         (6)
    Restore all CPU registers;             (7)
    Return from interrupt;                 (8)
}
```

- (1) `OSCtxSw()` must save all of the CPU registers onto the current task's stack. `OSCtxSw()` is called from the context of the task being switched out. Therefore, the CPU stack pointer is pointing to the proper stack. The user must save all of the registers in the same order as if an ISR started and all the CPU registers were saved on the stack. The stacking order should therefore match that of `OSTaskStkInit()`.
- (2) Save the current task's stack pointer into the current task's `OS_TCB`.
- (3) Next, `OSCtxSw()` must call `OSTaskSwHook()`.
- (4) Copy `OSPrioHighRdy` to `OSPrioCur`.
- (5) Copy `OSTCBHighRdyPtr` to `OSTCBCurPtr` since the current task is now the task being switched in.
- (6) Restore the stack pointer of the new task, which is found in the `OS_TCB` of the new task.
- (7) Restore all the CPU registers from the new task's stack.
- (8) Finally, `OSCtxSw()` must execute a return from interrupt instruction.

# OSFlagCreate ()

```
void OSFlagCreate (OS_FLAG_GRP *p_grp,
                  CPU_CHAR *p_name,
                  OS_FLAGS flags,
                  OS_ERR *p_err)
```

| File      | Called from          | Code enabled by |
|-----------|----------------------|-----------------|
| OS_FLAG.C | Task or startup code | OS_CFG_FLAG_EN  |

**OSFlagCreate()** is used to create and initialize an event flag group.  $\mu$ C/OS-III allows the user to create an unlimited number of event flag groups (limited only by the amount of RAM in the system).

## Arguments

**p\_grp** is a pointer to an event flag group that must be allocated in the application. The user will need to declare a “global” variable as shown, and pass a pointer to this variable to **OSFlagCreate()**:

```
OS_FLAG_GRP MyEventFlag;
```

**p\_name** is a pointer to an ASCII string used for the name of the event flag group. The name can be displayed by debuggers or by  $\mu$ C/Probe.

**flags** contains the initial value of the flags to store in the event flag group.

**p\_err** is a pointer to a variable that is used to hold an error code. The error code can be one of the following:

|                            |  |
|----------------------------|--|
| <b>OS_ERR_NONE</b>         | if the call is successful and the event flag group has been created.       |
| <b>OS_ERR_CREATE_ISR</b>   | if attempting to create an event flag group from an ISR, w is not allowed. |
| <b>OS_ERR_NAME</b>         | if <b>p_name</b> is a <b>NULL</b> pointer.                                 |
| <b>OS_ERR_OBJ_CREATED</b>  | if the object passed has already been created.                             |
| <b>OS_ERR_OBJ_PTR_NULL</b> | if <b>p_grp</b> is a <b>NULL</b> pointer.                                  |



## Returned Values

None

## Notes/Warnings

1. Event flag groups must be created by this function before they can be used by the other event flag group services.

## Example

```
OS_FLAG_GRP EngineStatus;

void main (void)
{
    OS_ERR err;

    OSInit(&err);          /* Initialize μC/OS-III          */
    :
    :
    OSFlagCreate(&EngineStatus,
                 "Engine Status",
                 (OS_FLAGS)0,
                 &err);   /* Create a flag grp containing the engine's status */
    /* Check "err" */
    :
    :
    OSStart();            /* Start Multitasking          */
}
```

# OSFlagDel ()

```
void OSFlagDel (OS_FLAG_GRP *p_grp,
               OS_OPT      opt,
               OS_ERR      *p_err);
```

| File      | Called from | Code enabled by                          |
|-----------|-------------|--|
| OS_FLAG.C | Task        | OS_CFG_FLAG_EN and<br>OS_CFG_FLAG_DEL_EN |

`OSFlagDel()` is used to delete an event flag group. This function should be used with care since multiple tasks may be relying on the presence of the event flag group. Generally, before deleting an event flag group, first delete all of the tasks that access the event flag group. Also, it is recommended that the user not delete kernel objects at run time.

## Arguments

`p_grp` is a pointer to the event flag group to delete.

`opt` specifies whether the user wants to delete the event flag group only if there are no pending tasks (`OS_OPT_DEL_NO_PEND`), or whether the event flag group should always be deleted regardless of whether or not tasks are pending (`OS_OPT_DEL_ALWAYS`). In this case, all pending task are readied.

`p_err` is a pointer to a variable used to hold an error code. The error code can be one of the following:

|                                  |  |
|----------------------------------|--|
| <code>OS_ERR_NONE</code>         | if the call is successful and the event flag group has been deleted.                                       |
| <code>OS_ERR_DEL_ISR</code>      | if the user attempts to delete an event flag group from an ISR.  |
| <code>OS_ERR_OBJ_PTR_NULL</code> | if <code>p_grp</code> is a <code>NULL</code> pointer.  |
| <code>OS_ERR_OBJ_TYPE</code>     | if <code>p_grp</code> is not pointing to an event flag group.  |
| <code>OS_ERR_OPT_INVALID</code>  | if the user does not specify one of the options mentioned in the <code>opt</code> argument.                |
| <code>OS_ERR_TASK_WAITING</code> | if one or more tasks are waiting on the event flag group and <code>OS_OPT_DEL_NO_PEND</code> is specified. |

### **Returned Values**

0 if no task was waiting on the event flag group, or an error occurs.

> 0 if one or more tasks waiting on the event flag group are now readied and informed

### **Notes/Warnings**

1. Use this call with care as other tasks might expect the presence of the event flag group.

### **Example**

```
OS_FLAG_GRP  EngineStatusFlags;

void Task (void *p_arg)
{
    OS_ERR      err;
    OS_OBJ_QTY  qty;

    (void)&p_arg;
    while (DEF_ON) {
        :
        :
        qty = OSFlagDel(&EngineStatusFlags,
                       OS_OPT_DEL_ALWAYS,
                       &err);
        /* Check "err" */
        :
        :
    }
}
```

# OSFlagPend()

```
OS_FLAGS OSFlagPend (OS_FLAG_GRP *p_grp,
                    OS_FLAGS flags,
                    OS_TICK timeout,
                    OS_OPT opt,
                    CPU_TS *p_ts,
                    OS_ERR *p_err)
```

| File      | Called from | Code enabled by |
|-----------|-------------|-----------------|
| OS_FLAG.C | Task        | OS_CFG_FLAG_EN  |

OSFlagPend() allows the task to wait for a combination of conditions (i.e., events or bits) to be set (or cleared) in an event flag group. The application can wait for any condition to be set or cleared, or for all conditions to be set or cleared. If the events that the calling task desires are not available, the calling task is blocked (optional) until the desired conditions are satisfied, the specified timeout expires, the event flag is deleted, or the pend is aborted by another task.

## Arguments

**p\_grp** is a pointer to the event flag group.

**flags** is a bit pattern indicating which bit(s) (i.e., flags) to check. The bits wanted are specified by setting the corresponding bits in flags. If the application wants to wait for bits 0 and 1 to be set, specify 0x03.

**timeout** allows the task to resume execution if the desired flag(s) is(are) not received from the event flag group within the specified number of clock ticks. A timeout value of 0 indicates that the task wants to wait forever for the flag(s). The timeout value is not synchronized with the clock tick. The timeout count begins decrementing on the next clock tick, which could potentially occur immediately.

**opt** specifies whether all bits are to be set/cleared or any of the bits are to be set/cleared. Specify the following arguments:

- OS\_OPT\_PEND\_FLAG\_CLR\_ALL      Check all bits in flags to be clear (0)
- OS\_OPT\_PEND\_FLAG\_CLR\_ANY      Check any bit in flags to be clear (0)

`OS_OPT_PEND_FLAG_SET_ALL` Check all bits in flags to be set (1)

`OS_OPT_PEND_FLAG_SET_ANY` Check any bit in flags to be set (1)

The user may also specify whether the flags are consumed by “adding”

`OS_OPT_PEND_FLAG_CONSUME` to the `opt` argument. For example, to wait for any flag in a group and then clear the flags that satisfy the condition, set `opt` to:

`OS_OPT_PEND_FLAG_SET_ANY + OS_OPT_PEND_FLAG_CONSUME`

Finally, you can specify whether the user wants to block if the flag(s) are available or not. The user must “add” the following options:

`OS_OPT_PEND_BLOCKING`

`OS_OPT_PEND_NON_BLOCKING`

Note that the timeout argument should be set to 0 when specifying `OS_OPT_PEND_NON_BLOCKING`, since the timeout value is irrelevant using this option.

`p_ts` is a pointer to a timestamp indicating when the flags were posted, the pend was aborted, or the event flag group was deleted. If passing a `NULL` pointer (i.e., `(CPU_TS *)0`), the user will not obtain the timestamp. Passing a `NULL` pointer is valid, and indicates that the user does not need the timestamp.

A timestamp is useful when the task desires to know when the event flag group was posted or how long it took for the task to resume after the event flag group was posted. In the latter case, the user must call `OS_TS_GET()` and compute the difference between the current value of the timestamp and `*p_ts`, as shown:

```
delta = OS_TS_GET() - *p_ts;
```

`p_err` is a pointer to an error code and can be:

`OS_ERR_NONE` No error.

`OS_ERR_OBJ_PTR_NULL` if `p_grp` is a `NULL` pointer.

`OS_ERR_OBJ_TYPE` `p_grp` is not pointing to an event flag group.

`OS_ERR_OPT_INVALID` the user specified an invalid option.

`OS_ERR_PEND_ABORT` the wait on the flags was aborted by another task that called `OSFlagPendAbort()`.

|                                      |  |
|--------------------------------------|--|
| <code>OS_ERR_PEND_ISR</code>         | An attempt was made to call <code>OSFlagPend</code> from an ISR, which is not allowed.   |
| <code>OS_ERR_SCHED_LOCKED</code>     | When calling this function while the scheduler was locked.   |
| <code>OS_ERR_PEND_WOULD_BLOCK</code> | if specifying non-blocking but the flags were not available and the call would block if the user had specified <code>OS_OPT_PEND_BLOCKING</code> . |
| <code>OS_ERR_TIMEOUT</code>          | the flags are not available within the specified amount of time.   |

### **Returned Values**

The flag(s) that cause the task to be ready, 0 if either none of the flags are ready, or indicate an error occurred.

### **Notes/Warnings**

1. The event flag group must be created before it is used.

## Example

```
#define ENGINE_OIL_PRES_OK    0x01
#define ENGINE_OIL_TEMP_OK   0x02
#define ENGINE_START         0x04

OS_FLAG_GRP EngineStatus;

void Task (void *p_arg)
{
    OS_ERR    err;
    OS_FLAGS  value;
    CPU_TS    ts;

    (void)&p_arg;
    while (DEF_ON) {
        value = OSFlagPend(&EngineStatus,
                           ENGINE_OIL_PRES_OK + ENGINE_OIL_TEMP_OK,
                           OS_FLAG_WAIT_SET_ALL + OS_FLAG_CONSUME,
                           10,
                           OS_OPT_PEND_BLOCKING,
                           &ts,
                           &err);

        /* Check "err" */
        :
        :
    }
}
```

# OSFlagPendAbort ()

```
OS_OBJ_QTY OSFlagPendAbort (OS_SEM *p_grp,
                             OS_OPT  opt,
                             OS_ERR  *p_err)
```

| File      | Called from | Code enabled by                                 |
|-----------|-------------|---|
| OS_FLAG.C | Task        | OS_CFG_FLAG_EN and<br>OS_CFG_FLAG_PEND_ABORT_EN |

**OSFlagPendAbort()** aborts and readies any tasks currently waiting on an event flag group. This function should be used by another task to fault abort the wait on the event flag group, rather than to normally signal the event flag group via **OSFlagPost()**.

## Arguments

**p\_grp** is a pointer to the event flag group for which pend(s) must be aborted.

**opt** determines the type of abort performed.

|                              |   |
|------------------------------|---|
| <b>OS_OPT_PEND_ABORT_1</b>   | Aborts the pend of only the highest priority task waiting on the event flag group.  |
| <b>OS_OPT_PEND_ABORT_ALL</b> | Aborts the pend of all the tasks waiting on the event flag group.   |
| <b>OS_OPT_POST_NO_SCHED</b>  | Specifies that the scheduler should not be called even if the pend of a higher priority task is aborted. Scheduling will need to occur from another function.<br>Use this option if the task calling <b>OSFlagPendAbort()</b> will perform additional pend aborts, rescheduling will take place at completion, and when multiple pend aborts are to take effect simultaneously. |



`p_err` is a pointer to a variable that holds an error code. `OSFlagPendAbort()` sets `*p_err` to one of the following:

|                                     |  |
|-------------------------------------|--|
| <code>OS_ERR_NONE</code>            | at least one task waiting on the event flag group was readied and informed of the aborted wait. Check the return value for the number of tasks where a wait on the event flag group was aborted. |
| <code>OS_ERR_OBJ_PTR_NULL</code>    | if <code>p_grp</code> is a <code>NULL</code> pointer.  |
| <code>OS_ERR_OBJ_TYPE</code>        | if <code>p_grp</code> is not pointing to an event flag group.  |
| <code>OS_ERR_OPT_INVALID</code>     | if specifying an invalid option.   |
| <code>OS_ERR_PEND_ABORT_ISR</code>  | This function cannot be called from an ISR.  |
| <code>OS_ERR_PEND_ABORT_NONE</code> | No task was aborted since no task was waiting.   |

### **Returned Value**

`OSFlagPendAbort()` returns the number of tasks made ready to run by this function. Zero indicates that no tasks were pending on the event flag group and thus this function had no effect.

### **Notes/Warnings**

1. Event flag groups must be created before they are used.

## Example

```
OS_FLAG_GRP EngineStatus;

void Task (void *p_arg)
{
    OS_ERR      err;
    OS_OBJ_QTY  nbr_tasks;

    (void)&p_arg;
    while (DEF_ON) {
        :
        :
        nbr_tasks = OSFlagPendAbort(&EngineStatus,
                                    OS_OPT_PEND_ABORT_ALL,
                                    &err);

        /* Check "err" */
        :
        :
    }
}
```

# OSFlagPendGetFlagsRdy()

OS\_FLAGS OSFlagPendGetFlagsRdy (OS\_ERR \*p\_err)

| File      | Called from | Code enabled by |
|-----------|-------------|-----------------|
| OS_FLAG.C | Task        | OS_CFG_FLAG_EN  |

OSFlagPendGetFlagsRdy() is used to obtain the flags that caused the current task to be ready to run. This function allows the user to know "Who done it!"

## Arguments

**p\_err** is a pointer to an error code and can be:

|                 |  |
|-----------------|--|
| OS_ERR_NONE     | No error.  |
| OS_ERR_PEND_ISR | When attempting to call this function from an ISR. |

## Returned Value

The value of the flags that caused the current task to become ready to run.

## Notes/Warnings

1. The event flag group must be created before it is used.

## Example

```
#define ENGINE_OIL_PRES_OK 0x01
#define ENGINE_OIL_TEMP_OK 0x02
#define ENGINE_START      0x04

OS_FLAG_GRP EngineStatus;

void Task (void *p_arg)
{
    OS_ERR    err;
    OS_FLAGS  value;
    OS_FLAGS  flags_rdy;

    (void)&p_arg;
    while (DEF_ON) {
        value = OSFlagPend(&EngineStatus,
                           ENGINE_OIL_PRES_OK + ENGINE_OIL_TEMP_OK,
                           OS_FLAG_WAIT_SET_ALL + OS_FLAG_CONSUME,
                           10,
                           &err);

        /* Check "err" */
        flags_rdy = OSFlagPendGetFlagsRdy(&err);
        /* Check "err" */
        :
        :
    }
}
```

# OSFlagPost ()

```
OS_FLAGS OSFlagPost (OS_FLAG_GRP *p_grp,  
                    OS_FLAGS      flags,  
                    OS_OPT        opt,  
                    OS_ERR        *p_err)
```

| File      | Called from | Code enabled by |
|-----------|-------------|-----------------|
| OS_FLAG.C | Task or ISR | OS_CFG_FLAG_EN  |

Set or clear event flag bits by calling `OSFlagPost()`. The bits set or cleared are specified in a bit mask (i.e., the flags argument). `OSFlagPost()` readies each task that has its desired bits satisfied by this call. The user can set or clear bits that are already set or cleared.

## Arguments

`p_grp` is a pointer to the event flag group.

`flags` specifies which bits to be set or cleared. If `opt` is `OS_OPT_POST_FLAG_SET`, each bit that is set in `flags` will set the corresponding bit in the event flag group. For example to set bits 0, 4, and 5, set `flags` to 0x31 (note that bit 0 is the least significant bit). If `opt` is `OS_OPT_POST_FLAG_CLR`, each bit that is set in `flags` will clear the corresponding bit in the event flag group. For example to clear bits 0, 4, and 5, specify `flags` as 0x31 (again, bit 0 is the least significant bit).

`opt` indicates whether the flags are set (`OS_OPT_POST_FLAG_SET`) or cleared (`OS_OPT_POST_FLAG_CLR`).

The user may also “add” `OS_OPT_POST_NO_SCHED` so that μC/OS-III will not call the scheduler after the post.

`p_err` is a pointer to an error code and can be:

- `OS_ERR_NONE` the call is successful.
- `OS_ERR_FLAG_INVALID_OPT` specify an invalid option.
- `OS_ERR_OBJ_PTR_NULL` the user passed a `NULL` pointer.
- `OS_ERR_OBJ_TYPE` the user is not pointing to an event flag group.

### Returned Value

The new value of the event flags.

### Notes/Warnings

- 1 Event flag groups must be created before they are used.
- 2 The execution time of this function depends on the number of tasks waiting on the event flag group. However, the execution time is still deterministic.
- 3 Although the example below shows that we are posting from a task, `OSFlagPost()` can also be called from an ISR.

### Example

```
#define ENGINE_OIL_PRES_OK    0x01
#define ENGINE_OIL_TEMP_OK   0x02
#define ENGINE_START         0x04

OS_FLAG_GRP EngineStatusFlags;

void TaskX (void *p_arg)
{
    OS_ERR    err;
    OS_FLAGS  flags;

    (void)&p_arg;
    while (DEF_ON) {
        :
        :
        flags = OSFlagPost(&EngineStatusFlags,
                           ENGINE_START,
                           OS_OPT_POST_FLAG_SET,
                           &err);

        /* Check 'err' */
        :
        :
    }
}
```

# OSIdleTaskHook ()

```
void OSIdleTaskHook (void);
```

| File       | Called from        | Code enabled by |
|------------|--------------------|-----------------|
| OS_CPU_C.C | OS_IdleTask() ONLY | N/A             |

This function is called by `OS_IdleTask()`.

`OSIdleTaskHook()` is part of the CPU port code and this function *must not* be called by the application code. `OSIdleTaskHook()` is used by the μC/OS-III port developer.

`OSIdleTaskHook()` runs in the context of the idle task so that it is important to make sure there is sufficient stack space in the idle task. `OSIdleTaskHook()` *must not* make any `OS??Pend()` calls, call `OSTaskSuspend()` or `OSTimeDly???`(). In other words, this function must never be allowed to make a blocking call.

## Arguments

None

## Returned Value

None

## Notes/Warnings

1. Never make blocking calls from `OSIdleTaskHook()`.
2. *Do not* call this function from you application.

## Example

The code below calls an application-specific hook that the application programmer can define. The user can simply set the value of `OS_AppIdleTaskHookPtr` to point to the desired hook function which in this case assumes `s` defined in `OS_APP_HOOKS.C`. The idle task calls `OSIdleTaskHook()` which in turns calls `App_OS_IdleTaskHook()` through `OS_AppIdleTaskHookPtr`.

This feature is very useful when there is a processor that can enter low-power mode. When  $\mu$ C/OS-III has no other task to run, the processor can be put to sleep waiting for an interrupt to wake it up.

```
void App_OS_IdleTaskHook (void)                                /* See OS_APP_HOOKS.C */
{
    /* Your code goes here! */
    /* Put the CPU in low power mode (optional) */
}

void App_OS_SetAllHooks (void)                                /* OS_APP_HOOKS.C */
{
    CPU_SR_ALLOC();

    CPU_CRITICAL_ENTER();
    :
    OS_AppIdleTaskHookPtr = App_OS_IdleTaskHook;
    :
    CPU_CRITICAL_EXIT();
}

void OSIdleTaskHook (void)                                    /* See OS_CPU_C.C */
{
    #if OS_CFG_APP_HOOKS_EN > 0u
        if (OS_AppIdleTaskHookPtr != (OS_APP_HOOK_VOID)0) { /* Call application hook */
            (*OS_AppIdleTaskHookPtr)();
        }
    #endif
}
```



# OSInit()

```
void OSInit (OS_ERR *p_err);
```

| File      | Called from       | Code enabled by |
|-----------|-------------------|-----------------|
| OS_CORE.C | Startup code only | N/A             |

OSInit() initializes μC/OS-III and it must be called prior to calling any other μC/OS-III function. Including OSStart() which will start multitasking.

## Arguments

**p\_err** is a pointer to an error code and can be:

|             |  |
|-------------|--|
| OS_ERR_NONE | initialization was successful.                                       |
| OS_ERR_???? | some other OS_ERR_???? value returned by a sub-function of OSInit(). |

## Returned Values

None

## Notes/Warnings

1. OSInit() must be called before OSStart().
2. OSInit() returns as soon as it detects an error in any of the sub-functions it calls. For example, if OSInit() encounters a problem initializing the task manager, an appropriate error code will be returned and OSInit() will not go any further. It is therefore important that the user checks the error code before starting multitasking.

## Example

```
void main (void)
{
    OS_ERR  err;

    :
    OSInit(&err);           /* Initialize  $\mu$ C/OS-III      */
    /* Check "err" */
    :
    :
    OSStart(&err);         /* Start Multitasking      */
    /* Check "err" */     /* Code not supposed to end up here! */
}
}
```

# OSInitHook ()

void OSInitHook (void);

| File       | Called from | Code enabled by |
|------------|-------------|-----------------|
| OS_CPU_C.C | OSInit()    | Always enabled  |

OSInitHook() is a function that is called by μC/OS-III's initialization code, OSInit(). OSInitHook() is typically implemented by the port implementer for the processor used. This hook allows the port to be extended to do such tasks as setup exception stacks, floating-point registers, and more. OSInitHook() is called at the beginning of OSInit(), before any μC/OS-III task and data structure have been initialized.

## Arguments

None

## Returned Values

None

## Notes/Warnings

None

## Example

```
void OSInitHook (void) /* See OS_CPU_C.C */
{
    /* Perform any initialization code necessary by the port */
}
```

## OSIntCtxSw ()

void OSIntCtxSw (void)

| File         | Called from | Code enabled by |
|--------------|-------------|-----------------|
| OS_CPU_A.ASM | OSIntExit() | N/A             |

OSIntCtxSw() is called from OSIntExit() to perform a context switch when all nested interrupts have returned.

Interrupts are disabled when OSIntCtxSw() is called.

OSIntExit() sets OSTCBCurPtr to point at the OS\_TCB of the task that is switched out and OSTCBHighRdyPtr to point at the OS\_TCB of the task that is switched in.

### Arguments

None

### Returned Values

None

### Notes/Warnings

None

### **Example**

The pseudocode for `OSIntCtxSw()` is shown below. Notice that the code does only half of what `OSCtxSw()` did. The reason is that `OSIntCtxSw()` is called from an ISR and it is assumed that all of the CPU registers of the interrupted task were saved at the beginning of the ISR. `OSIntCtxSw()` therefore only must restore the context of the new, high-priority task.

```
void OSIntCtxSw (void)
{
    OSTaskSwHook();                (1)
    OSPrioCur      = OSPrioHighRdy;  (2)
    OSTCBCurPtr    = OSTCBHighRdyPtr; (3)
    SP              = OSTCBHighRdyPtr->StkPtr; (4)
    Restore all CPU registers;        (5)
    Return from interrupt;            (6)
}
```

- (1) `OSIntCtxSw()` must call `OSTaskSwHook()`.
- (2) Copy `OSPrioHighRdy` to `OSPrioCur`.
- (3) Copy `OSTCBHighRdyPtr` to `OSTCBCurPtr` because the current task will now be the new task.
- (4) Restore the stack pointer of the new task, which is found in the `OS_TCB` of the new task.
- (5) Restore all the CPU registers from the new task's stack.
- (6) Execute a return from interrupt instruction.

---

# OSIntEnter ()

```
void OSIntEnter (void);
```

| File      | Called from | Code enabled by |
|-----------|-------------|-----------------|
| OS_CORE.C | ISR only    | N/A             |

`OSIntEnter()` notifies  $\mu\text{C}/\text{OS-III}$  that an ISR is being processed, which allows  $\mu\text{C}/\text{OS-III}$  to keep track of interrupt nesting. `OSIntEnter()` is used in conjunction with `OSIntExit()`. This function is generally called at the beginning of ISRs. Note that on some CPU architectures, it must be written in assembly language (shown below in pseudo code):

```
MyISR:
    Save CPU registers;
    OSIntEnter();          /* Or, OSIntNestingCtr++ */
    :
    Process ISR;
    :
    OSIntExit();
    Restore CPU registers;
    Return from interrupt;
```

## Arguments

None

## Returned Values

None

## Notes/Warnings

1. This function must not be called by task-level code.
2. Increment the interrupt-nesting counter (`OSIntNestingCtr`) directly in the ISR to avoid the overhead of the function call/return. It is safe to increment `OSIntNestingCtr` in the ISR since interrupts are assumed to be disabled when `OSIntNestingCtr` is incremented. However, that is not true for all CPU architectures. Make sure interrupts are disabled in the ISR before directly incrementing `OSIntNestingCtr`.
3. It is possible to nest interrupts up to 250 levels deep.

# OSIntExit()

`void OSIntExit (void);`

| File      | Called from | Code enabled by |
|-----------|-------------|-----------------|
| OS_CORE.C | ISR only    | N/A             |

`OSIntExit()` notifies  $\mu\text{C}/\text{OS-III}$  that an ISR is complete, which allows  $\mu\text{C}/\text{OS-III}$  to keep track of interrupt nesting. `OSIntExit()` is used in conjunction with `OSIntEnter()`. When the last nested interrupt completes, `OSIntExit()` determines if a higher priority task is ready to run. If so, the interrupt returns to the higher priority task instead of the interrupted task.

This function is typically called at the end of ISRs as follows, and on some CPU architectures, it must be written in assembly language (shown below in pseudo code):

```
MyISR:
    Save CPU registers;
    OSIntEnter();
    :
    Process ISR;
    :
    OSIntExit();
    Restore CPU registers;
    Return from interrupt;
```

## Arguments

None

## Returned Value

None

## Notes/Warnings

1. This function must not be called by task-level code. Also, if directly incrementing `OSIntNestingCtr`, instead of calling `OSIntEnter()`, the user must still call `OSIntExit()`.

# OSMemCreate ()

```
void OSMemCreate (OS_MEM      *p_mem,
                  CPU_CHAR    *p_name,
                  void         *p_addr,
                  OS_MEM_QTY  n_blks,
                  OS_MEM_SIZE blk_size,
                  OS_ERR       *p_err)
```

| File     | Called from          | Code enabled by |
|----------|----------------------|-----------------|
| OS_MEM.C | Task or startup code | OS_CFG_MEM_EN   |

`OSMemCreate()` creates and initializes a memory partition. A memory partition contains a user-specified number of fixed-size memory blocks. An application may obtain one of these memory blocks and, when completed, release the block back to the same partition where the block originated.

## Arguments

`p_mem` is a pointer to a memory partition control block that must be allocated in the application. It is assumed that storage will be allocated for the memory control blocks in the application. In other words, the user will declare a “global” variable as follows, and pass a pointer to this variable to `OSMemCreate()`:

```
OS_MEM MyMemPartition;
```

`p_name` is a pointer to an ASCII string to provide a name to the memory partition. The name can be displayed by debuggers or  $\mu$ C/Probe.

`p_addr` is the address of the start of a memory area used to create fixed-size memory blocks. Memory partitions may be created either using static arrays or `malloc()` during startup. Note that the partition *must* align on a pointer boundary. Thus, if a pointer is 16-bits wide, the partition must start on a memory location with an address that ends with 0, 2, 4, 6, 8, etc. If a pointer is 32-bits wide, the partition must start on a memory location with an address that ends in 0, 4, 8 of C. The easiest way to ensure this is to create a static array as follows:

```
void *MyMemArray[N][M * sizeof(void *)]
```



Never deallocate memory blocks that were allocated from the heap to prevent fragmentation of your heap. It is quite acceptable to allocate memory blocks from the heap as long as the user does not deallocate them.

**n\_blks** contains the number of memory blocks available from the specified partition. Specify at least two memory blocks per partition.

**blk\_size** specifies the size (in bytes) of each memory block within a partition. A memory block must be large enough to hold at least a pointer. Also, the size of a memory block must be a multiple of the size of a pointer. If a pointer is 32-bits wide then the block size must be 4, 8, 12, 16, 20, etc. bytes (i.e., a multiple of 4 bytes).

**p\_err** is a pointer to a variable that holds an error code:

|                                  |   |
|----------------------------------|---|
| <b>OS_ERR_NONE</b>               | if the memory partition is created successfully   |
| <b>OS_ERR_MEM_INVALID_BLKS</b>   | if the user does not specify at least two memory blocks per partition   |
| <b>OS_ERR_MEM_INVALID_P_ADDR</b> | if specifying an invalid address (i.e., <b>p_addr</b> is a <b>NULL</b> pointer) or the partition is not properly aligned.                       |
| <b>OS_ERR_MEM_INVALID_SIZE</b>   | if the user does not specify a block size that can contain at least a pointer variable, and if it is not a multiple of a pointer-size variable. |

### **Returned Value**

None

### **Notes/Warnings**

1. Memory partitions must be created before they are used.

## Example

```
OS_MEM      CommMem;
CPU_INT32U  *CommBuf[16][32];          /* 16 buffers of 32 words of 32 bits */

void main (void)
{
    OS_ERR  err;

    OSInit(&err);                       /* Initialize  $\mu$ C/OS-III          */
    :
    :
    OSMemCreate(&CommMem,
                "Comm Buffers",
                &CommBuf[0][0],
                16,
                32 * sizeof(CPU_INT32U),
                &err);
    /* Check "err" */
    :
    :
    OSStart(&err);                       /* Start Multitasking          */
}
```

# OSMemGet ( )

```
void *OSMemGet (OS_MEM *p_mem,  
                OS_ERR *p_err)
```

| File     | Called from | Code enabled by |
|----------|-------------|-----------------|
| OS_MEM.C | Task or ISR | OS_CFG_MEM_EN   |

OSMemGet() obtains a memory block from a memory partition. It is assumed that the application knows the size of each memory block obtained. Also, the application must return the memory block [using OSMemPut()] to the same memory partition when it no longer requires it. OSMemGet() may be called more than once until all memory blocks are allocated.

## Arguments

**p\_mem** is a pointer to the desired memory partition control block.

**p\_err** is a pointer to a variable that holds an error code:

- OS\_ERR\_NONE if a memory block is available and returned to the application.
- OS\_ERR\_MEM\_INVALID\_P\_MEM if p\_mem is a NULL pointer.
- OS\_ERR\_MEM\_NO\_FREE\_BLKs if the memory partition does not contain additional memory blocks to allocate.

## Returned Value

OSMemGet() returns a pointer to the allocated memory block if one is available. If a memory block is not available from the memory partition, OSMemGet() returns a NULL pointer. It is up to the application to “cast” the pointer to the proper data type since OSMemGet() returns a void \*.

## Notes/Warnings

1. Memory partitions must be created before they are used.
2. This is a non-blocking call and this function can be called from an ISR.

## Example

```
OS_MEM  CommMem;

void Task (void *p_arg)
{
    OS_ERR      err;
    CPU_INT08U  *p_msg;

    (void)&p_arg;
    while (DEF_ON) {
        p_msg = (CPU_INT08U *)OSMemGet(&CommMem,
                                       &err);

        /* Check "err" */
        :
        :
    }
}
```

# OSMemPut ( )

```
void OSMemPut (OS_MEM *p_mem,  
              void *p_blk,  
              OS_ERR *p_err)
```

| File     | Called from | Code enabled by |
|----------|-------------|-----------------|
| OS_MEM.C | Task or ISR | OS_CFG_MEM_EN   |

OSMemPut( ) returns a memory block back to a memory partition. It is assumed that the user will return the memory block to the same memory partition from which it was allocated.

## Arguments

**p\_mem** is a pointer to the memory partition control block.

**p\_blk** is a pointer to the memory block to be returned to the memory partition.

**p\_err** is a pointer to a variable that holds an error code:

|                          |   |
|--------------------------|---|
| OS_ERR_NONE              | if a memory block is available and returned to the application.   |
| OS_ERR_MEM_INVALID_P_BLK | if the user passed a NULL pointer for the memory block being returned to the memory partition.  |
| OS_ERR_MEM_INVALID_P_MEM | if p_mem is a NULL pointer.   |
| OS_ERR_MEM_MEM_FULL      | if returning a memory block to an already full memory partition. This would indicate that the user freed more blocks that were allocated and potentially did not return some of the memory blocks to the proper memory partition. |

## Returned Value

None

### Notes/Warnings

1. Memory partitions must be created before they are used.
2. Return a memory block to the proper memory partition.
3. Call this function from an ISR or a task.

### Example

```
OS_MEM      CommMem;
CPU_INT08U  *CommMsg;

void Task (void *p_arg)
{
    OS_ERR err;

    (void)&p_arg;
    while (DEF_ON) {
        OSMemPut(&CommMem,
                (void *)CommMsg,
                &err);
        /* Check "err" */
        :
        :
    }
}
```

# OSMutexCreate ()

```
void OSMutexCreate (OS_MUTEX    *p_mutex,  
                   CPU_CHAR     *p_name,  
                   OS_ERR       *p_err)
```

| File       | Called from          | Code enabled by |
|------------|----------------------|-----------------|
| OS_MUTEX.C | Task or startup code | OS_CFG_MUTEX_EN |

OSMutexCreate() is used to create and initialize a mutex. A mutex is used to gain exclusive access to a resource.

## Arguments

**p\_mutex** is a pointer to a mutex control block that must be allocated in the application. The user will need to declare a “global” variable as follows, and pass a pointer to this variable to OSMutexCreate():

```
OS_MUTEX MyMutex;
```

**p\_name** is a pointer to an ASCII string used to assign a name to the mutual exclusion semaphore. The name may be displayed by debuggers or µC/Probe.

**p\_err** is a pointer to a variable that is used to hold an error code:

|                     |   |
|---------------------|---|
| OS_ERR_NONE         | if the call is successful and the mutex has been created.                               |
| OS_ERR_CREATE_ISR   | if attempting to create a mutex from an ISR.  |
| OS_ERR_OBJ_CREATED  | if p_mutex already points to a mutex. This indicates that the mutex is already created. |
| OS_ERR_OBJ_PTR_NULL | if p_mutex is a NULL pointer.   |
| OS_ERR_OBJ_TYPE     | if p_mutex points to a different type of object (semaphore, message queue or timer).    |

## Returned Value

None

## Notes/Warnings

1. Mutexes must be created before they are used.

## Example

```
OS_MUTEX  DispMutex;

void main (void)
{
    OS_ERR  err;

    :
    OSInit(&err);                /* Initialize  $\mu$ C/OS-III      */
    :
    :
    OSMutexCreate(&DispMutex,    /* Create Display Mutex      */
                  "Display Mutex",
                  &err);
    /* Check "err" */

    :
    :
    OSStart(&err);              /* Start Multitasking        */
}
}
```



# OSMutexDel ()

```
void OSMutexDel (OS_MUTEX *p_mutex,  
                 OS_OPT   opt,  
                 OS_ERR   *p_err)
```

| File       | Called from | Code enabled by                            |
|------------|-------------|--|
| OS_MUTEX.C | Task        | OS_CFG_MUTEX_EN and<br>OS_CFG_MUTEX_DEL_EN |

OSMutexDel() is used to delete a mutex. This function should be used with care because multiple tasks may rely on the presence of the mutex. Generally speaking, before deleting a mutex, first delete all the tasks that access the mutex. However, as a general rule, do not delete kernel objects at run-time.

### Arguments

**p\_mutex** is a pointer to the mutex to delete.

**opt** specifies whether to delete the mutex only if there are no pending tasks (OS\_OPT\_DEL\_NO\_PEND), or whether to always delete the mutex regardless of whether tasks are pending or not (OS\_OPT\_DEL\_ALWAYS). In this case, all pending task are readied.

**p\_err** is a pointer to a variable that is used to hold an error code:

- OS\_ERR\_NONE if the call is successful and the mutex has been deleted.
- OS\_ERR\_DEL\_ISR if attempting to delete a mutex from an ISR.
- OS\_ERR\_OBJ\_PTR\_NULL if p\_mutex is a NULL pointer.
- OS\_ERR\_OBJ\_TYPE if p\_mutex is not pointing to a mutex.
- OS\_ERR\_OPT\_INVALID if the user does not specify one of the two options mentioned in the opt argument.
- OS\_ERR\_TASK\_WAITING if one or more task are waiting on the mutex and OS\_OPT\_DEL\_NO\_PEND is specified.

### Returned Value

The number of tasks that were waiting for the mutex and 0 if an error occurred.

## Notes/Warnings

1. Use this call with care as other tasks may expect the presence of the mutex.

## Example

```
OS_MUTEX  DispMutex;

void Task (void *p_arg)
{
    OS_ERR  err;

    (void)&p_arg;
    while (DEF_ON) {
        :
        :
        OSMutexDel(&DispMutex,
                   OS_OPT_DEL_ALWAYS,
                   &err);
        /* Check "err" */
        :
        :
    }
}
```

# OSMutexPend()

```
void OSMutexPend (OS_MUTEX  *p_mutex,  
                 OS_TICK   timeout,  
                 OS_OPT    opt,  
                 CPU_TS    *p_ts,  
                 OS_ERR    *p_err)
```

| File       | Called from | Code enabled by |
|------------|-------------|-----------------|
| OS_MUTEX.C | Task only   | OS_CFG_MUTEX_EN |

**OSMutexPend()** is used when a task requires exclusive access to a resource. If a task calls **OSMutexPend()** and the mutex is available, **OSMutexPend()** gives the mutex to the caller and returns to its caller. Note that nothing is actually given to the caller except that if **p\_err** is set to **OS\_ERR\_NONE**, the caller can assume that it owns the mutex.

However, if the mutex is already owned by another task, **OSMutexPend()** places the calling task in the wait list for the mutex. The task waits until the task that owns the mutex releases the mutex and therefore the resource, or until the specified timeout expires. If the mutex is signaled before the timeout expires, μC/OS-III resumes the highest-priority task that is waiting for the mutex.

Note that if the mutex is owned by a lower-priority task, **OSMutexPend()** raises the priority of the task that owns the mutex to the same priority as the task requesting the mutex. The priority of the owner will be returned to its original priority when the owner releases the mutex (see **OSMutexPost()**).

**OSMutexPend()** allows nesting. The same task can call **OSMutexPend()** multiple times. However, the same task must then call **OSMutexPost()** an equivalent number of times to release the mutex.

## Arguments

**p\_mutex** is a pointer to the mutex.

**timeout** specifies a timeout value (in clock ticks) and is used to allow the task to resume execution if the mutex is not signaled (i.e., posted to) within the specified timeout. A timeout value of 0 indicates that the task wants to wait forever for the mutex. The timeout value is not synchronized with the clock tick. The timeout count is decremented on the next clock tick, which could potentially occur immediately.

**opt** determines whether the user wants to block if the mutex is not available or not. This argument must be set to either:

`OS_OPT_PEND_BLOCKING`, or

`OS_OPT_PEND_NON_BLOCKING`

Note that the timeout argument should be set to 0 when specifying `OS_OPT_PEND_NON_BLOCKING` since the timeout value is irrelevant using this option.

**p\_ts** is a pointer to a timestamp indicating when the mutex was posted, the pend was aborted, or the mutex was deleted. If passing a `NULL` pointer (i.e., `(CPU_TS *)0`), the user will not receive the timestamp. In other words, passing a `NULL` pointer is valid and indicates that the timestamp is not required.

A timestamp is useful when it is important for a task to know when the mutex was posted, or how long it took for the task to resume after the mutex was posted. In the latter case, the user must call `OS_TS_GET()` and compute the difference between the current value of the timestamp and `*p_ts`. In other words:

```
delta = OS_TS_GET() - *p_ts;
```

**p\_err** is a pointer to a variable that is used to hold an error code:

`OS_ERR_NONE` if the call is successful and the mutex is available.

`OS_ERR_MUTEX_NESTING` if the calling task already owns the mutex and it has not posted all nested values.

`OS_ERR_MUTEX_OWNER` if the calling task already owns the mutex.

`OS_ERR_OBJ_PTR_NULL` if `p_mutex` is a `NULL` pointer.

|                                  |   |
|----------------------------------|---|
| <code>OS_ERR_OBJ_TYPE</code>     | if the user did not pass a pointer to a mutex.              |
| <code>OS_ERR_OPT_INVALID</code>  | if a valid option is not specified.                         |
| <code>OS_ERR_PEND_ISR</code>     | if attempting to acquire the mutex from an ISR.             |
| <code>OS_ERR_SCHED_LOCKED</code> | if calling this function when the scheduler is locked       |
| <code>OS_ERR_TIMEOUT</code>      | if the mutex is not available within the specified timeout. |

### Returned Value

None

### Notes/Warnings

1. Mutexes must be created before they are used.
2. Do not suspend the task that owns the mutex. Also, do not have the mutex owner wait on any other  $\mu$ C/OS-III objects (i.e., semaphore, event flag, or queue), and delay the task that owns the mutex. The code should release the resource as quickly as possible.

### Example

```
OS_MUTEX  DispMutex;

void DispTask (void *p_arg)
{
    OS_ERR  err;
    CPU_TS  ts;

    (void)&p_arg;
    while (DEF_ON) {
        :
        OSMutexPend(&DispMutex,
                    0,
                    OS_OPT_PEND_BLOCKING,
                    &ts,
                    &err);
        /* Check "err" */
    }
}
```

# OSMutexPendAbort ()

```
void OSMutexPendAbort (OS_MUTEX *p_mutex,
                      OS_OPT   opt,
                      OS_ERR   *p_err)
```

| File       | Called from | Code enabled by                                   |
|------------|-------------|---|
| OS_MUTEX.C | Task        | OS_CFG_MUTEX_EN and<br>OS_CFG_MUTEX_PEND_ABORT_EN |

OSMutexPendAbort() aborts and readies any tasks currently waiting on a mutex. This function should be used to fault-abort the wait on the mutex rather than to normally signal the mutex via OSMutexPost().

## Arguments

**p\_mutex** is a pointer to the mutex.

**opt** specifies whether to abort only the highest-priority task waiting on the mutex or all tasks waiting on the mutex:

**OS\_OPT\_PEND\_ABORT\_1** to abort only the highest-priority task waiting on the mutex.

**OS\_OPT\_PEND\_ABORT\_ALL** to abort all tasks waiting on the mutex.

**OS\_OPT\_POST\_NO\_SCHED** specifies that the scheduler should not be called even if the pend of a higher-priority task has been aborted. Scheduling will need to occur from another function.

The user would select this option if the task calling OSMutexPendAbort() will be doing additional pend aborts, rescheduling should not take place until all tasks are completed, and multiple pend aborts should take place simultaneously.

**p\_err** is a pointer to a variable that is used to hold an error code:

|                                     |   |
|-------------------------------------|---|
| <code>OS_ERR_NONE</code>            | if at least one task was aborted. Check the return value for the number of tasks aborted. |
| <code>OS_ERR_OBJ_PTR_NULL</code>    | if <code>p_mutex</code> is a NULL pointer.  |
| <code>OS_ERR_OBJ_TYPE</code>        | if the user does not pass a pointer to a mutex.   |
| <code>OS_ERR_OPT_INVALID</code>     | if the user specified an invalid option.  |
| <code>OS_ERR_PEND_ABORT_ISR</code>  | if attempting to call this function from an ISR   |
| <code>OS_ERR_PEND_ABORT_NONE</code> | if no tasks were aborted.   |

### Returned Value

`OSMutexPendAbort()` returns the number of tasks made ready to run by this function. Zero indicates that no tasks were pending on the mutex and therefore this function had no effect.

### Notes/Warnings

1. Mutexes must be created before they are used.

### Example

```
OS_MUTEX  DispMutex;

void DispTask (void *p_arg)
{
    OS_ERR    err;
    OS_OBJ_QTY qty;

    (void)&p_arg;
    while (DEF_ON) {
        :
        :
        qty = OSMutexPendAbort(&DispMutex,
                               OS_OPT_PEND_ABORT_ALL,
                               &err);

        /* Check "err" */
    }
}
```

# OSMutexPost()

```
void OSMutexPost (OS_MUTEX  *p_mutex,
                  OS_OPT    opt,
                  OS_ERR    *p_err);
```

| File       | Called from | Code enabled by |
|------------|-------------|-----------------|
| OS_MUTEX.C | Task        | OS_CFG_MUTEX_EN |

A mutex is signaled (i.e., released) by calling `OSMutexPost()`. Call this function only if acquiring the mutex by first calling `OSMutexPend()`. If the priority of the task that owns the mutex has been raised when a higher priority task attempted to acquire the mutex, at that point, the original task priority of the task is restored. If one or more tasks are waiting for the mutex, the mutex is given to the highest-priority task waiting on the mutex. The scheduler is then called to determine if the awakened task is now the highest-priority task ready to run, and if so, a context switch is done to run the readied task. If no task is waiting for the mutex, the mutex value is simply set to available (`DEF_TRUE`).

## Arguments

`p_mutex` is a pointer to the mutex.

`opt` determines the type of POST performed.

`OS_OPT_POST_NONE`

No special option selected.

`OS_OPT_POST_NO_SCHED`

Do not call the scheduler after the post, therefore the caller is resumed even if the mutex was posted and tasks of higher priority are waiting for the mutex.

Use this option if the task calling `OSMutexPost()` will be doing additional posts, if the user does not want to reschedule until all is complete, and multiple posts should take effect simultaneously.



**p\_err** is a pointer to a variable that is used to hold an error code:

|                                     |  |
|-------------------------------------|--|
| <code>OS_ERR_NONE</code>            | if the call is successful and the mutex is available.  |
| <code>OS_ERR_MUTEX_NESTING</code>   | if the owner of the mutex has the mutex nested and it has not fully un-nested the mutex yet. |
| <code>OS_ERR_MUTEX_NOT_OWNER</code> | if the caller is not the owner of the mutex and therefore is not allowed to release it.      |
| <code>OS_ERR_OBJ_PTR_NULL</code>    | if <code>p_mutex</code> is a <code>NULL</code> pointer.                                      |
| <code>OS_ERR_OBJ_TYPE</code>        | if not passing a pointer to a mutex.   |
| <code>OS_ERR_POST_ISR</code>        | if attempting to post the mutex from an ISR.   |

### Returned Value

None

### Notes/Warnings

1. Mutexes must be created before they are used.
2. Do not call this function from an ISR.

### Example

```
OS_MUTEX  DispMutex;

void TaskX (void *p_arg)
{
    OS_ERR  err;

    (void)&p_arg;
    while (DEF_ON) {
        :
        OSMutexPost(&DispMutex,
                    OS_OPT_POST_NONE,
                    &err);
        /* Check "err" */
        :
    }
}
```

# OSPendMulti()

```
OS_OBJ_QTY  OSPendMulti(OS_PEND_DATA  *p_pend_data_tbl,
                        OS_OBJ_QTY    tbl_size,
                        OS_TICK        timeout,
                        OS_OPT         opt,
                        OS_ERR         *p_err);
```

| File            | Called from | Code enabled by   |
|-----------------|-------------|---|
| OS_PEND_MULTI.C | Task        | OS_CFG_PEND_MULTI_EN &&<br>(OS_CFG_Q_EN    OS_CFG_SEM_EN) |

`OSPendMulti()` is used when a task expects to wait on multiple kernel objects, specifically semaphores or message queues. If more than one such object is ready when `OSPendMulti()` is called, then all available objects and messages, if any, are returned as ready to the caller. If no objects are ready, `OSPendMulti()` suspends the current task until either:

- an object becomes ready,
- a timeout occurs,
- one or more of the tasks are deleted or pend aborted or,
- one or more of the objects are deleted.

If an object becomes ready, and multiple tasks are waiting for the object,  $\mu\text{C}/\text{OS-III}$  resumes the highest-priority task waiting on that object.

A pended task suspended with `OSTaskSuspend()` can still receive a message from a multi-pended message queue, or obtain a signal from a multi-pended semaphore. However, the task remains suspended until it is resumed by calling `OSTaskResume()`.

## Arguments

`p_pend_data_tbl` is a pointer to an `OS_PEND_DATA` table. This table will be used by the caller to understand the outcome of this call. Also, the caller *must* initialize the `.PendObjPtr` field of the `OS_PEND_DATA` field for each object that the caller wants to pend on (see example below).

**tbl\_size** is the number of entries in the **OS\_PEND\_DATA** table pointed to by **p\_pend\_data\_tbl**. This value indicates how many objects the task will be pending on.

**timeout** specifies the amount of time (in clock ticks) that the calling task is willing to wait for objects to be posted. A timeout value of 0 indicates that the task wants to wait forever for any of the multi-pended objects. The timeout value is not synchronized with the clock tick. The timeout count begins decrementing on the next clock tick, which could potentially occur immediately.

**p\_err** is a pointer to a variable that holds an error code:

|                                |  |
|--------------------------------|--|
| <b>OS_ERR_NONE</b>             | if any of the multi-pended objects are ready.  |
| <b>OS_ERR_OBJ_TYPE</b>         | if any of the <b>.PendObjPtr</b> in the <b>p_pend_data_tbl</b> is a NULL pointer, not a semaphore, or not a message queue.   |
| <b>OS_ERR_OPT_INVALID</b>      | if specifying an invalid option.   |
| <b>OS_ERR_PEND_ABORT</b>       | indicates that a multi-pended object was aborted; check the <b>.RdyObjPtr</b> of the <b>p_pend_data_tbl</b> to know which object was aborted. The first non-NULL <b>.RdyObjPtr</b> is the object that was aborted. |
| <b>OS_ERR_PEND_DEL</b>         | indicates that a multi-pended object was deleted; check the <b>.RdyObjPtr</b> of the <b>p_pend_data_tbl</b> to know which object was deleted. The first non-NULL <b>.RdyObjPtr</b> is the object that was deleted. |
| <b>OS_ERR_PEND_ISR</b>         | if calling this function from an ISR.  |
| <b>OS_ERR_PEND_LOCKED</b>      | if calling this function when the scheduler is locked.   |
| <b>OS_ERR_PEND_WOULD_BLOCK</b> | if the caller does not want to block and no object is ready.   |
| <b>OS_ERR_PTR_INVALID</b>      | if <b>p_pend_data_tbl</b> is a NULL pointer.   |
| <b>OS_ERR_TIMEOUT</b>          | if no multi-pended object is ready within the specified timeout.   |

### Returned Value

`OSPendMulti()` returns the number of multi-pended objects that are ready. If an object is pend aborted or deleted, the return value will be 1. Examine the value of `*p_err` to know the exact outcome of this call. If no multi-pended object is ready within the specified timeout period, or because of any error, the `.RdyObjPtr` in the `p_pend_data_tbl` array will all be `NULL`.

When objects are posted, the `OS_PEND_DATA` fields of `p_pend_data_tbl` contains additional information about the posted objects:

|                          |  |
|--------------------------|--|
| <code>.RdyObjPtr</code>  | Contains a pointer to the object ready or posted to, or <code>NULL</code> pointer if the object was not ready or posted to.  |
| <code>.RdyMsgPtr</code>  | If the object pended on was a message queue and the queue was posted to, this field contains the message.  |
| <code>.RdyMsgSize</code> | If the object pended on was a message queue and the queue was posted to, this field contains the size of the message (in number of bytes).   |
| <code>.RdyTS</code>      | If the object pended on was posted to, this field contains the timestamp as to when the object was posted. Note that if the object is deleted or pend-aborted, this field contains the timestamp of when the condition occurred. |

### Notes/Warnings

1. Message queue or semaphore objects must be created before they are used.
2. Do call `OSPendMulti()` from an ISR.
3. The user cannot multi-pend on event flags and mutexes.

## Example

```
OS_SEM Sem1;
OS_SEM Sem2;
OS_Q Q1;
OS_Q Q2;

void Task(void *p_arg)
{
    OS_PEND_DATA pend_data_tbl[4];
    OS_ERR err;
    OS_OBJ_QTY nbr_rdy;

    (void)&p_arg;
    while (DEF_ON) {
        :
        pend_data_tbl[0].PendObjPtr = (OS_PEND_OBJ *)Sem1;
        pend_data_tbl[1].PendObjPtr = (OS_PEND_OBJ *)Sem2;
        pend_data_tbl[2].PendObjPtr = (OS_PEND_OBJ *)Q1;
        pend_data_tbl[3].PendObjPtr = (OS_PEND_OBJ *)Q2;
        nbr_rdy = OSPendMulti(&pend_data_tbl[0],
                               4,
                               0,
                               OS_OPT_PEND_BLOCKING,
                               &err);

        /* Check "err" */
        :
        :
    }
}
```

# OSQCreate ()

```
void OSQCreate (OS_Q      *p_q,
                CPU_CHAR  *p_name,
                OS_MSG_QTY max_qty,
                OS_ERR     *p_err)
```

| File   | Called from          | Code enabled by               |
|--------|----------------------|-------------------------------|
| OS_Q.C | Task or startup code | OS_CFG_Q_EN and OS_CFG_MSG_EN |

**OSQCreate()** creates a message queue. A message queue allows tasks or ISRs to send pointer-sized variables (messages) to one or more tasks. The meaning of the messages sent are application specific.

## Arguments

**p\_q** is a pointer to the message queue control block. It is assumed that storage for the message queue will be allocated in the application. The user will need to declare a “global” variable as follows, and pass a pointer to this variable to **OSQCreate()**:

```
OS_Q MyMsgQ;
```

**p\_name** is a pointer to an ASCII string used to name the message queue. The name can be displayed by debuggers or  $\mu$ C/Probe.

**msg\_size** indicates the maximum size of the message queue (must be non-zero). If the user intends to not limit the size of the queue, simply pass a very large number. Of course, if there are not enough **OS\_MSGs** in the pool of **OS\_MSGs**, the post call (i.e., **OSQPost()**) will simply fail and an error code will indicate that there are no more **OS\_MSGs** to use.

**p\_err** is a pointer to a variable that is used to hold an error code:

|                                  |   |
|----------------------------------|---|
| <code>OS_ERR_NONE</code>         | if the call is successful and the mutex has been created.   |
| <code>OS_ERR_CREATE_ISR</code>   | if attempting to create the message queue from an ISR.  |
| <code>OS_ERR_NAME</code>         | if <code>p_name</code> is a <code>NULL</code> pointer.  |
| <code>OS_ERR_OBJ_CREATED</code>  | if <code>p_q</code> is already pointing to a message queue. In other words, the user is trying to create a message queue that has already been created. |
| <code>OS_ERR_OBJ_PTR_NULL</code> | if <code>p_q</code> is a <code>NULL</code> pointer.   |
| <code>OS_ERR_Q_SIZE</code>       | if the size specified is 0.   |

### Returned Value

None

### Notes/Warnings

1. Queues must be created before they are used.

### Example

```
OS_Q  CommQ;

void main (void)
{
    OS_ERR  err;

    OSInit(&err);                /* Initialize μC/OS-III */
    :
    :
    OSQCreate(&CommQ,
              "Comm Queue",
              10,
              &err);            /* Create COMM Q */
    /* Check "err" */
    :
    :
    OSStart();                  /* Start Multitasking */
}
```

# OSQDel ()

```
OS_OBJ_QTY OSQDel (OS_Q    *p_q,
                  OS_OPT  opt,
                  OS_ERR  *p_err)
```

| File   | Called from | Code enabled by                    |
|--------|-------------|------------------------------------|
| os_q.c | Task        | OS_CFG_Q_EN and<br>OS_CFG_Q_DEL_EN |

`OSQDel()` is used to delete a message queue. This function should be used with care since multiple tasks may rely on the presence of the message queue. Generally speaking, before deleting a message queue, first delete all the tasks that can access the message queue. However, it is highly recommended that you do not delete kernel objects at run time.

## Arguments

`p_q` is a pointer to the message queue to delete.

`opt` specifies whether to delete the queue only if there are no pending tasks (`OS_OPT_DEL_NO_PEND`), or always delete the queue regardless of whether tasks are pending or not (`OS_OPT_DEL_ALWAYS`). In this case, all pending task are readied.

`p_err` is a pointer to a variable that is used to hold an error code. The error code can be one of the following:

|                                  |  |
|----------------------------------|--|
| <code>OS_ERR_NONE</code>         | if the call is successful and the message queue has been deleted.  |
| <code>OS_ERR_DEL_ISR</code>      | if the user attempts to delete the message queue from an ISR.  |
| <code>OS_ERR_OBJ_PTR_NULL</code> | if passing a <code>NULL</code> pointer for <code>p_q</code> .  |
| <code>OS_ERR_OBJ_TYPE</code>     | if <code>p_q</code> is not pointing to a queue.  |
| <code>OS_ERR_OPT_INVALID</code>  | if not specifying one of the two options mentioned in the <code>opt</code> argument.   |
| <code>OS_ERR_TASK_WAITING</code> | if one or more tasks are waiting for messages at the message queue and it is specified to only delete if no task is pending. |



### **Returned Value**

The number of tasks that were waiting on the message queue and 0 if an error is detected.

### **Notes/Warnings**

1. Message queues must be created before they can be used.
2. This function must be used with care. Tasks that would normally expect the presence of the queue *must* check the return code of `OSQPend()`.

### **Example**

```
OS_Q  DispQ;

void Task (void *p_arg)
{
    OS_ERR  err;

    (void)&p_arg;
    while (DEF_ON) {
        :
        :
        OSQDel(&DispQ,
              OS_OPT_DEL_ALWAYS,
              &err);
        /* Check "err" */
        :
        :
    }
}
```

# OSQFlush()

```
OS_MSG_QTY OSQFlush (OS_Q *p_q,
                    OS_ERR *p_err)
```

| File   | Called from | Code enabled by                      |
|--------|-------------|--------------------------------------|
| os_q.c | Task        | OS_CFG_Q_EN and<br>OS_CFG_Q_FLUSH_EN |

OSQFlush() empties the contents of the message queue and eliminates all messages sent to the queue. This function takes the same amount of time to execute regardless of whether tasks are waiting on the queue (and thus no messages are present), or the queue contains one or more messages. OS\_MSGs from the queue are simply returned to the free pool of OS\_MSGs.

## Arguments

**p\_q** is a pointer to the message queue.

**p\_err** is a pointer to a variable that will contain an error code returned by this function.

|                     |   |
|---------------------|---|
| OS_ERR_NONE         | if the message queue is flushed.                              |
| OS_ERR_FLUSH_ISR    | if calling this function from an ISR                          |
| OS_ERR_OBJ_PTR_NULL | if p_q is a NULL pointer.                                     |
| OS_ERR_OBJ_TYPE     | if you attempt to flush an object other than a message queue. |

## Returned Value

The number of OS\_MSG entries freed from the message queue. Note that the OS\_MSG entries are returned to the free pool of OS\_MSGs.

## Notes/Warnings

1. Queues must be created before they are used.

2. Use this function with great care. When flushing a queue, you lose the references to what the queue entries are pointing to, potentially causing 'memory leaks'. The data that the user is pointing to that is referenced by the queue entries should, most likely, be de-allocated (i.e., freed). To flush a queue that contains entries, instead use `OSQPend()` with the `OS_OPT_PEND_NON_BLOCKING` option.

### **Example**

```
OS_Q  CommQ;

void Task (void *p_arg)
{
    OS_ERR  err;

    (void)&p_arg;
    while (DEF_ON) {
        :
        :
        entries = OSQFlush(&CommQ,
                          &err);
        /* Check "err" */
        :
        :
    }
}
```

## OSQPend ( )

```
void *OSQPend (OS_Q          *p_q,
               OS_TICK      timeout,
               OS_OPT        opt,
               OS_MSG_SIZE  *p_msg_size,
               CPU_TS        *p_ts,
               OS_ERR        *p_err)
```

| File   | Called from | Code enabled by               |
|--------|-------------|-------------------------------|
| OS_Q.C | Task        | OS_CFG_Q_EN and OS_CFG_MSG_EN |

**OSQPend()** is used when a task wants to receive messages from a message queue. The messages are sent to the task via the message queue either by an ISR, or by another task using the **OSQPost()** call. The messages received are pointer-sized variables, and their use is application specific. If at least one message is already present in the message queue when **OSQPend()** is called, the message is retrieved and returned to the caller.

If no message is present in the message queue and **OS\_OPT\_PEND\_BLOCKING** is specified for the **opt** argument, **OSQPend()** suspends the current task (assuming the scheduler is not locked) until either a message is received, or a user-specified timeout expires. If a message is sent to the message queue and multiple tasks are waiting for such a message,  $\mu$ C/OS-III resumes the highest priority task that is waiting.

A pended task suspended with **OSTaskSuspend()** can receive a message. However, the task remains suspended until it is resumed by calling **OSTaskResume()**.

If no message is present in the queue and **OS\_OPT\_PEND\_NON\_BLOCKING** is specified for the **opt** argument, **OSQPend()** returns to the caller with an appropriate error code, and returns a **NULL** pointer.

## **Arguments**

**p\_q** is a pointer to the queue from which the messages are received.

**timeout** allows the task to resume execution if a message is not received from the message queue within the specified number of clock ticks. A timeout value of 0 indicates that the task is willing to wait forever for a message. The timeout value is not synchronized with the clock tick. The timeout count starts decrementing on the next clock tick, which could potentially occur immediately.

**opt** determines whether or not to block if a message is not available in the queue. This argument must be set to either:

`OS_OPT_PEND_BLOCKING`, or

`OS_OPT_PEND_NON_BLOCKING`

Note that the timeout argument should be set to 0 when specifying `OS_OPT_PEND_NON_BLOCKING`, since the timeout value is irrelevant using this option.

**p\_msg\_size** is a pointer to a variable that will receive the size of the message (in number of bytes).

**p\_ts** is a pointer to a variable that will receive the timestamp of when the message was received. If passing a `NULL` pointer (i.e., `(CPU_TS *)0`), the timestamp will not be returned. Passing a `NULL` pointer is valid, and indicates that the user does not need the timestamp.

A timestamp is useful when the user wants the task to know when the message queue was posted, or how long it took for the task to resume after the message queue was posted. In the latter case, call `OS_TS_GET()` and compute the difference between the current value of the timestamp and `*p_ts`. In other words:

```
delta = OS_TS_GET() - *p_ts;
```

`p_err` is a pointer to a variable used to hold an error code.

|                                      |  |
|--------------------------------------|--|
| <code>OS_ERR_NONE</code>             | if a message is received.  |
| <code>OS_ERR_OBJ_PTR_NULL</code>     | if <code>p_q</code> is a <code>NULL</code> pointer.  |
| <code>OS_ERR_OBJ_TYPE</code>         | if <code>p_q</code> is not pointing to a message queue.  |
| <code>OS_ERR_PEND_ABORT</code>       | if the pend was aborted because another task called <code>OSQPendAbort()</code> .  |
| <code>OS_ERR_PEND_ISR</code>         | if the function is called from an ISR.   |
| <code>OS_ERR_PEND_WOULD_BLOCK</code> | if this function is called with the <code>opt</code> argument set to <code>OS_OPT_PEND_NON_BLOCKING</code> , and no message is in the queue. |
| <code>OS_ERR_SCHED_LOCKED</code>     | if calling this function when the scheduler is locked.   |
| <code>OS_ERR_TIMEOUT</code>          | if a message is not received within the specified timeout.   |

### Returned Value

The message (i.e., a pointer) or a `NULL` pointer if no messages has been received. Note that it is possible for the actual message to be `NULL` pointers, so check the returned error code instead of relying on the returned value.

### Notes/Warnings

1. Queues must be created before they are used.
2. The user cannot call `OSQPend()` from an ISR.

## Example

```
OS_Q  CommQ;

void CommTask (void *p_arg)
{
    OS_ERR      err;
    void        *p_msg;
    OS_MSG_SIZE msg_size;
    CPU_TS      ts;

    (void)&p_arg;
    while (DEF_ON) {
        :
        :
        p_msg = OSQPend(CommQ,
                       100,
                       OS_OPT_PEND_BLOCKING,
                       &msg_size,
                       &ts,
                       &err);
        /* Check "err" */
        :
        :
    }
}
```

# OSQPendAbort ( )

```
OS_OBJ_QTY OSQPendAbort (OS_Q    *p_q,
                          OS_OPT   opt,
                          OS_ERR   *p_err)
```

| File   | Called from | Code enabled by                           |
|--------|-------------|---|
| os_q.c | Task only   | OS_CFG_Q_EN and<br>OS_CFG_Q_PEND_ABORT_EN |

`OSQPendAbort()` aborts and readies any tasks currently waiting on a message queue. This function should be used to fault-abort the wait on the message queue, rather than to signal the message queue via `OSQPost()`.

## Arguments

`p_q` is a pointer to the queue for which pend(s) need to be aborted.

`opt` determines the type of abort to be performed.

|                                    |  |
|------------------------------------|--|
| <code>OS_OPT_PEND_ABORT_1</code>   | Aborts the pend of only the highest-priority task waiting on the message queue.  |
| <code>OS_OPT_PEND_ABORT_ALL</code> | Aborts the pend of all tasks waiting on the message queue.   |
| <code>OS_OPT_POST_NO_SCHED</code>  | specifies that the scheduler should not be called, even if the pend of a higher-priority task has been aborted. Scheduling will need to occur from another function.<br>Use this option if the task calling <code>OSQPendAbort()</code> is doing additional pend aborts, rescheduling is not performed until completion, and multiple pend aborts are to take effect simultaneously. |

`p_err` is a pointer to a variable that holds an error code:



|                                     |  |
|-------------------------------------|--|
| <code>OS_ERR_NONE</code>            | at least one task waiting on the message queue was readied and informed of the aborted wait. Check the return value for the number of tasks whose wait on the message queue was aborted. |
| <code>OS_ERR_PEND_ABORT_ISR</code>  | if called from an ISR  |
| <code>OS_ERR_PEND_ABORT_NONE</code> | if no task was pending on the message queue  |
| <code>OS_ERR_OBJ_PTR_NULL</code>    | if <code>p_q</code> is a <code>NULL</code> pointer.  |
| <code>OS_ERR_OBJ_TYPE</code>        | if <code>p_q</code> is not pointing to a message queue.  |
| <code>OS_ERR_OPT_INVALID</code>     | if an invalid option is specified.   |

### Returned Value

`OSQPendAbort()` returns the number of tasks made ready to run by this function. Zero indicates that no tasks were pending on the message queue, therefore this function had no effect.

### Notes/Warnings

1. Queues must be created before they are used.

### Example

```
OS_Q  CommQ;

void CommTask(void *p_arg)
{
    OS_ERR      err;
    OS_OBJ_QTY  nbr_tasks;

    (void)&p_arg;
    while (DEF_ON) {
        :
        :
        nbr_tasks = OSQPendAbort(&CommQ,
                                OS_OPT_PEND_ABORT_ALL,
                                &err);

        /* Check "err" */
        :
        :
    }
}
```

# OSQPost()

```
void OSQPost (OS_Q      *p_q,
              void      *p_void,
              OS_MSG_SIZE msg_size,
              OS_OPT     opt,
              OS_ERR     *p_err)
```

| File   | Called from | Code enabled by |
|--------|-------------|-----------------|
| os_q.c | Task or ISR | OS_CFG_Q_EN     |

**OSQPost()** sends a message to a task through a message queue. A message is a pointer-sized variable, and its use is application specific. If the message queue is full, an error code is returned to the caller. In this case, **OSQPost()** immediately returns to its caller, and the message is not placed in the message queue.

If any task is waiting for a message to be posted to the message queue, the highest-priority task receives the message. If the task waiting for the message has a higher priority than the task sending the message, the higher-priority task resumes, and the task sending the message is suspended; that is, a context switch occurs. Message queues can be first-in first-out (**OS\_OPT\_POST\_FIFO**), or last-in-first-out (**OS\_OPT\_POST\_LIFO**) depending of the value specified in the **opt** argument.

If any task is waiting for a message at the message queue, **OSQPost()** allows the user to either post the message to the highest-priority task waiting at the queue (**opt** set to **OS\_OPT\_POST\_FIFO** or **OS\_OPT\_POST\_LIFO**), or to all tasks waiting at the message queue (**opt** is set to **OS\_OPT\_POST\_ALL**). In either case, scheduling occurs unless **opt** is also set to **OS\_OPT\_POST\_NO\_SCHED**.

## Arguments

**p\_q** is a pointer to the message queue being posted to.

**p\_void** is the actual message posted. **p\_void** is a pointer-sized variable. Its meaning is application specific.

**msg\_size** specifies the size of the message (in number of bytes).

**opt** determines the type of POST performed. The last two options may be added to either `OS_OPT_POST_FIFO` or `OS_OPT_POST_LIFO` to create different combinations:

|                                   |  |
|-----------------------------------|--|
| <code>OS_OPT_POST_FIFO</code>     | POST message to the end of the queue (FIFO), or send message to a single waiting task.   |
| <code>OS_OPT_POST_LIFO</code>     | POST message to the front of the queue (LIFO), or send message to a single waiting task  |
| <code>OS_OPT_POST_ALL</code>      | POST message to ALL tasks that are waiting on the queue. This option can be added to either <code>OS_OPT_POST_FIFO</code> or <code>OS_OPT_POST_LIFO</code> .   |
| <code>OS_OPT_POST_NO_SCHED</code> | Do not call the scheduler after the post and therefore the caller is resumed, even if the message was posted to a message queue with tasks having a higher priority than the caller. Use this option if the task (or ISR) calling <code>OSQPost()</code> will do additional posts, the user does not want to reschedule until finished, and, multiple posts are to take effect simultaneously. |

**p\_err** is a pointer to a variable that will contain an error code returned by this function.

|                                    |  |
|------------------------------------|--|
| <code>OS_ERR_NONE</code>           | if no tasks were waiting on the queue. In this case, the return value is also 0. |
| <code>OS_ERR_MSG_POOL_EMPTY</code> | if there are no more <code>OS_MSG</code> structures to use to store the message. |
| <code>OS_ERR_OBJ_PTR_NULL</code>   | if <code>p_q</code> is a <code>NULL</code> pointer.                              |
| <code>OS_ERR_OBJ_TYPE</code>       | if <code>p_q</code> is not pointing to a message queue.                          |
| <code>OS_ERR_Q_MAX</code>          | if the queue is full and therefore cannot accept more messages.                  |

### **Returned Value**

None

### Notes/Warnings

1. Queues must be created before they are used.
2. Possible combinations of options are:

```
OS_OPT_POST_FIFO
OS_OPT_POST_LIFO
OS_OPT_POST_FIFO + OS_OPT_POST_ALL
OS_OPT_POST_LIFO + OS_OPT_POST_ALL
OS_OPT_POST_FIFO + OS_OPT_POST_NO_SCHED
OS_OPT_POST_LIFO + OS_OPT_POST_NO_SCHED
OS_OPT_POST_FIFO + OS_OPT_POST_ALL + OS_OPT_POST_NO_SCHED
OS_OPT_POST_LIFO + OS_OPT_POST_ALL + OS_OPT_POST_NO_SCHED
```

3. Although the example below shows calling OSQPost() from a task, it can also be called from an ISR.

### Example

```
OS_Q          CommQ;
CPU_INT08U   CommRxBuf[100];

void CommTaskRx (void *p_arg)
{
    OS_ERR  err;

    (void)&p_arg;
    while (DEF_ON) {
        :
        :
        OSQPost(&CommQ,
                &CommRxBuf[0],
                sizeof(CommRxBuf),
                OS_OPT_POST_OPT_FIFO + OS_OPT_POST_ALL + OS_OPT_POST_NO_SCHED,
                &err);
        /* Check "err" */
        :
        :
    }
}
```

# OSSafetyCriticalStart()

void OSSafetyCriticalStart (void)

| File      | Called from | Code enabled by             |
|-----------|-------------|-----------------------------|
| OS_CORE.C | Task        | OS_SAFETY_CRITICAL_IEC61508 |

OSSafetyCriticalStart() allows your code to notify μC/OS-III that you are done initializing and creating all kernel objects. After calling OSSafetyCriticalStart(), your application code will no longer be allowed to create kernel objects.

## Arguments

None

## Returned Value

None

## Notes/Warnings

None

## Example

```
void AppStartTask (void *p_arg)
{
    (void)&p_arg;
    /* Create tasks and other kernel objects */
    OSSafetyCriticalStart();
    /* Your code is no longer allowed to create kernel objects */
    while (DEF_ON) {
        :
        :
    }
}
```

# OSSched()

void OSSched (void)

| File      | Called from | Code enabled by |
|-----------|-------------|-----------------|
| OS_CORE.C | Task        | N/A             |

OSSched() allows a task to call the scheduler. Use this function if creating a series of “posts” and specifying OS\_OPT\_POST\_NO\_SCHED as a post option.

OSSched() can only be called by task-level code. Also, if the scheduler is locked (i.e., OSSchedLock() was previously called), then OSSched() will have no effect.

If a higher-priority task than the calling task is ready to run, OSSched() will context switch to that task.

## Arguments

None

## Returned Value

None

## Notes/Warnings

None

## **Example**

```
void TaskX (void *p_arg)
{
    (void)&p_arg;
    while (DEF_ON) {
        :
        OS??Post(...);          /* Posts with OS_OPT_POST_NO_SCHED option      */
        /* Check "err" */
        OS??Post(...);
        /* Check "err" */
        OS??Post(...);
        /* Check "err" */
        :
        OSSched();              /* Run the scheduler                */
        :
    }
}
```

# OSSchedLock ( )

```
void OSSchedLock (OS_ERR *p_err)
```

| File      | Called from | Code enabled by |
|-----------|-------------|-----------------|
| OS_CORE.C | Task or ISR | N/A             |

`OSSchedLock()` prevents task rescheduling until its counterpart, `OSSchedUnlock()`, is called. The task that calls `OSSchedLock()` retains control of the CPU, even though other higher-priority tasks are ready to run. However, interrupts are still recognized and serviced (assuming interrupts are enabled). `OSSchedLock()` and `OSSchedUnlock()` must be used in pairs.

$\mu$ C/OS-III allows `OSSchedLock()` to be nested up to 250 levels deep. Scheduling is enabled when an equal number of `OSSchedUnlock()` calls have been made.

## Arguments

`p_err` is a pointer to a variable that will contain an error code returned by this function.

|                                      |   |
|--------------------------------------|---|
| <code>OS_ERR_NONE</code>             | the scheduler is locked.  |
| <code>OS_ERR_LOCK_NESTING_OVF</code> | if the user called this function too many times.                  |
| <code>OS_ERR_OS_NOT_RUNNING</code>   | if the function is called before calling <code>OSStart()</code> . |

## Returned Value

None

## Notes/Warnings

- After calling `OSSchedLock()`, the application must not make system calls that suspend execution of the current task; that is, the application cannot call `OSTimeDly()`, `OSTimeDlyHMSM()`, `OSFlagPend()`, `OSSemPend()`, `OSMutexPend()`, or `OSQPend()`. Since the scheduler is locked out, no other task is allowed to run, and the system will lock up.



## **Example**

```
void TaskX (void *p_arg)
{
    OS_ERR  err;

    (void)&p_arg;
    while (DEF_ON) {
        :
        OSSchedLock(&err);    /* Prevent other tasks to run      */
        /* Check "err" */
        :                    /* Code protected from context switch */
        OSSchedUnlock(&err); /* Enable other tasks to run      */
        /* Check "err" */
        :
    }
}
```

# OSSchedRoundRobinCfg ( )

```
void OSSchedRoundRobinCfg (CPU_BOOLEAN en,
                           OS_TICK     dflt_time_quanta,
                           OS_ERR      *p_err)
```

| File      | Called from          | Code enabled by             |
|-----------|----------------------|-----------------------------|
| OS_CORE.C | Task or startup code | OS_CFG_SCHED_ROUND_ROBIN_EN |

OSSchedRoundRobinCfg() is used to enable or disable round-robin scheduling.

## Arguments

**en** when set to `DEF_ENABLED` enables round-robin scheduling, and when set to `DEF_DISABLED` disables it.

**dflt\_time\_quanta** is the default time quanta given to a task. This value is used when a task was created and specified a value of 0 for the time quanta. In other words, if the user did not specify a non-zero for the task's time quanta, this is the value that will be used. If passing 0 for this argument,  $\mu$ C/OS-III will assume a time quanta of 1/10 the tick rate. For example, if the tick rate is 1000 Hz and 0 for `dflt_time_quanta` is specified,  $\mu$ C/OS-III will set the time quanta to 10 milliseconds.

**p\_err** is a pointer to a variable that is used to hold an error code:

`OS_ERR_NONE` if the call is successful.

## Returned Value

None

## Notes/Warnings

None

## Example

```
void main (void)
{
    OS_ERR  err;

    :
    OSInit(&err);          /* Initialize μC/OS-III          */
    :
    :
    OSSchedRoundRobinCfg(DEF_ENABLED,
                        10,
                        &err);
    /* Check "err" */
    :
    :
    OSStart(&err);        /* Start Multitasking          */
}
}
```

---

# OSSchedRoundRobinYield()

```
void OSSchedRoundRobinYield (OS_ERR *p_err);
```

| File      | Called from | Code enabled by             |
|-----------|-------------|-----------------------------|
| OS_CORE.C | Task        | OS_CFG_SCHED_ROUND_ROBIN_EN |

OSSchedRoundRobinYield() is used to voluntarily give up a task's time slot, assuming that there are other tasks running at the same priority.

## Arguments

**p\_err** is a pointer to a variable used to hold an error code:

|                             |  |
|-----------------------------|--|
| OS_ERR_NONE                 | if the call was successful.  |
| OS_ERR_ROUND_ROBIN_1        | if there is only one task at the current priority level that is ready to run.                    |
| OS_ERR_ROUND_ROBIN_DISABLED | if round-robin scheduling has not been enabled. See OSSchedRoundRobinCfg() to enable or disable. |
| OS_ERR_SCHED_LOCKED         | if the scheduler is locked and $\mu$ C/OS-III cannot switch tasks.                               |
| OS_ERR_YIELD_ISR            | if calling this function from an ISR.  |

## Returned Value

None

## Notes/Warnings

None

## **Example**

```
void Task (void *p_arg)
{
    OS_ERR  err;

    (void)&p_arg;
    while (DEF_ON) {
        :
        :
        OSSchedRoundRobinYield(&err); /* Give up the CPU to the next task at same priority */
        /* Check "err" */
        :
        :
    }
}
```

# OSSchedUnlock ()

```
void OSSchedUnlock(OS_ERR *p_err);
```

| File      | Called from | Code enabled by |
|-----------|-------------|-----------------|
| OS_CORE.C | Task or ISR | N/A             |

OSSchedUnlock() re-enables task scheduling whenever it is paired with OSSchedLock().

## Arguments

**p\_err** is a pointer to a variable that will contain an error code returned by this function.

|                         |  |
|-------------------------|--|
| OS_ERR_NONE             | the call is successful and the scheduler is no longer locked.                                    |
| OS_ERR_OS_NOT_RUNNING   | if calling this function before calling OSStart().   |
| OS_ERR_SCHED_LOCKED     | if the scheduler is still locked. This would indicate that scheduler lock has not fully unnested |
| OS_ERR_SCHED_NOT_LOCKED | if the user did not call OSSchedLock().  |

## Returned Value

None

## Notes/Warnings

None

## Example

```
void TaskX (void *p_arg)
{
    OS_ERR  err;

    (void)&p_arg;
    while (DEF_ON) {
        :
        OSSchedLock(&err);    /* Prevent other tasks to run      */
        /* Check "err" */
        :                      /* Code protected from context switch */
        OSSchedUnlock(&err); /* Enable other tasks to run      */
        /* Check "err" */
        :
    }
}
```

# OSSemCreate ()

```
void OS_SemCreate (OS_SEM      *p_sem,
                  CPU_CHAR    *p_name,
                  OS_SEM_CTR   cnt,
                  OS_ERR       *p_err)
```

| File     | Called from          | Code enabled by |
|----------|----------------------|-----------------|
| OS_SEM.C | Task or startup code | OS_CFG_SEM_EN   |

**OS\_SemCreate()** initializes a semaphore. Semaphores are used when a task wants exclusive access to a resource, needs to synchronize its activities with an ISR or a task, or is waiting until an event occurs. Use a semaphore to signal the occurrence of an event to one or multiple tasks, and use mutexes to guard share resources. However, technically, semaphores allow for both.

## Arguments

**p\_sem** is a pointer to the semaphore control block. It is assumed that storage for the semaphore will be allocated in the application. In other words, declare a “global” variable as follows, and pass a pointer to this variable to **OS\_SemCreate()**:

```
OS_SEM MySem;
```

**p\_name** is a pointer to an ASCII string used to assign a name to the semaphore. The name can be displayed by debuggers or  $\mu$ C/Probe.

**cnt** specifies the initial value of the semaphore.

If the semaphore is used for resource sharing, set the initial value of the semaphore to the number of identical resources guarded by the semaphore. If there is only one resource, the value should be set to 1 (this is called a binary semaphore). For multiple resources, set the value to the number of resources (this is called a counting semaphore).

If using a semaphore as a signaling mechanism, set the initial value to 0.



**p\_err** is a pointer to a variable used to hold an error code:

|                                  |  |
|----------------------------------|--|
| <code>OS_ERR_NONE</code>         | if the call is successful and the semaphore has been created.          |
| <code>OS_ERR_CREATE_ISR</code>   | if calling this function from an ISR.                                  |
| <code>OS_ERR_NAME</code>         | if <code>p_name</code> is a <code>NULL</code> pointer.                 |
| <code>OS_ERR_OBJ_CREATED</code>  | if the semaphore is already created.                                   |
| <code>OS_ERR_OBJ_PTR_NULL</code> | if <code>p_q</code> is a <code>NULL</code> pointer.                    |
| <code>OS_ERR_OBJ_TYPE</code>     | if <code>p_sem</code> has been initialized to a different object type. |

### Returned Value

None

### Notes/Warnings

Semaphores must be created before they are used.

### Example

```
OS_SEM SwSem;

void main (void)
{
    OS_ERR err;

    :
    OSInit(&err);           /* Initialize μC/OS-III          */
    :
    :
    OSSemCreate(&SwSem,    /* Create Switch Semaphore      */
                "Switch Semaphore",
                0,
                &err);
    /* Check "err" */
    :
    :
    OSStart(&err);        /* Start Multitasking          */
}
}
```

## OSSemDel ()

```
void OSSemDel (OS_SEM *p_sem,
              OS_OPT  opt,
              OS_ERR  *p_err)
```

| File     | Called from | Code enabled by                        |
|----------|-------------|--|
| OS_SEM.C | Task        | OS_CFG_SEM_EN and<br>OS_CFG_SEM_DEL_EN |

`OSSemDel()` is used to delete a semaphore. This function should be used with care as multiple tasks may rely on the presence of the semaphore. Generally speaking, before deleting a semaphore, first delete all the tasks that access the semaphore. As a rule, it is highly recommended to not delete kernel objects at run time.

Deleting the semaphore will not de-allocate the object. In other words, storage for the variable will still remain at the same location unless the semaphore is allocated dynamically from the heap. The dynamic allocation of objects has its own set of problems. Specifically, it is not recommended for embedded systems to allocate (and de-allocate) objects from the heap given the high likelihood of fragmentation.

### Arguments

`p_sem` is a pointer to the semaphore.

`opt` specifies one of two options: `OS_OPT_DEL_NO_PEND` or `OS_OPT_DEL_ALWAYS`.

`OS_OPT_DEL_NO_PEND` specifies to delete the semaphore only if no task is waiting on the semaphore. Because no task is “currently” waiting on the semaphore does not mean that a task will not attempt to wait for the semaphore later. How would such a task handle the situation waiting for a semaphore that was deleted? The application code will have to deal with this eventuality.

`OS_OPT_DEL_ALWAYS` specifies deleting the semaphore, regardless of whether tasks are waiting on the semaphore or not. If there are tasks waiting on the semaphore, these tasks will be made ready to run and informed (through an appropriate error code) that the reason the task is readied is that the

semaphore it was waiting on was deleted. The same reasoning applies with the other option, how will the tasks handle the fact that the semaphore they want to wait for is no longer available?

**p\_err** is a pointer to a variable used to hold an error code. The error code may be one of the following:

|                                  |  |
|----------------------------------|--|
| <code>OS_ERR_NONE</code>         | if the call is successful and the semaphore has been deleted.                          |
| <code>OS_ERR_DEL_ISR</code>      | if attempting to delete the semaphore from an ISR.                                     |
| <code>OS_ERR_OBJ_PTR_NULL</code> | if <code>p_sem</code> is a <code>NULL</code> pointer.                                  |
| <code>OS_ERR_OBJ_TYPE</code>     | if <code>p_sem</code> is not pointing to a semaphore.                                  |
| <code>OS_ERR_OPT_INVALID</code>  | if one of the two options mentioned in the <code>opt</code> argument is not specified. |
| <code>OS_ERR_TASK_WAITING</code> | if one or more tasks are waiting on the semaphore.                                     |

**Returned Value**

None

**Notes/Warnings**

Use this call with care because other tasks might expect the presence of the semaphore.

## Example

```
OS_SEM SwSem;

void Task (void *p_arg)
{
    OS_ERR err;

    (void)&p_arg;
    while (DEF_ON) {
        :
        :
        OS_SemDel(&SwSem,
                 OS_OPT_DEL_ALWAYS,
                 &err);
        /* Check "err" */
        :
        :
    }
}
```

# OSSemPend ( )

```
OS_SEM_CTR  OSSemPend (OS_SEM      *p_sem,  
                      OS_TICK      timeout,  
                      OS_OPT        opt,  
                      CPU_TS        *p_ts,  
                      OS_ERR        *p_err)
```

| File     | Called from | Code enabled by |
|----------|-------------|-----------------|
| OS_SEM.C | Task only   | OS_CFG_SEM_EN   |

**OSSemPend()** is used when a task wants exclusive access to a resource, needs to synchronize its activities with an ISR or task, or is waiting until an event occurs.

When the semaphore is used for resource sharing, if a task calls **OSSemPend()** and the value of the semaphore is greater than 0, **OSSemPend()** decrements the semaphore and returns to its caller. However, if the value of the semaphore is 0, **OSSemPend()** places the calling task in the waiting list for the semaphore. The task waits until the owner of the semaphore (which is always a task in this case) releases the semaphore by calling **OSSemPost()**, or the specified timeout expires. If the semaphore is signaled before the timeout expires, μC/OS-III resumes the highest-priority task waiting for the semaphore.

When the semaphore is used as a signaling mechanism, the calling task waits until a task or an ISR signals the semaphore by calling **OSSemPost()**, or the specified timeout expires. If the semaphore is signaled before the timeout expires, μC/OS-III resumes the highest-priority task waiting for the semaphore.

A pended task that has been suspended with **OSTaskSuspend()** can obtain the semaphore. However, the task remains suspended until it is resumed by calling **OSTaskResume()**.

**OSSemPend()** also returns if the pend is aborted or, the semaphore is deleted.

## Arguments

**p\_sem** is a pointer to the semaphore.

**timeout** allows the task to resume execution if a semaphore is not posted within the specified number of clock ticks. A timeout value of 0 indicates that the task waits forever for the semaphore. The timeout value is not synchronized with the clock tick. The timeout count begins decrementing on the next clock tick, which could potentially occur immediately.

**opt** specifies whether the call is to block if the semaphore is not available, or not block.

**OS\_OPT\_PEND\_BLOCKING** to block the caller until the semaphore is available or a timeout occurs.

**OS\_OPT\_PEND\_NON\_BLOCKING** if the semaphore is not available, **OSSemPend()** will not block but return to the caller with an appropriate error code.

**p\_ts** is a pointer to a variable that will receive a timestamp of when the semaphore was posted, pend aborted, or deleted. Passing a **NULL** pointer is valid and indicates that a timestamp is not required.

A timestamp is useful when the task must know when the semaphore was posted or, how long it took for the task to resume after the semaphore was posted. In the latter case, call **CPU\_BOOLEAN()** and compute the difference between the current value of the timestamp and **\*p\_ts**. In other words:

```
delta = OS_TS_GET() - *p_ts;
```

**p\_err** is a pointer to a variable used to hold an error code:

**OS\_ERR\_NONE** if the semaphore is available.

**OS\_ERR\_OBJ\_DEL** if the semaphore was deleted.

**OS\_ERR\_OBJ\_PTR\_NULL** if **p\_sem** is a **NULL** pointer.

**OS\_ERR\_OBJ\_TYPE** if **p\_sem** is not pointing to a semaphore.

**OS\_ERR\_PEND\_ABORT** if the pend was aborted

**OS\_ERR\_PEND\_ISR** if this function is called from an ISR.

**OS\_ERR\_PEND\_WOULD\_BLOCK** if this function is called as specified **OS\_OPT\_PEND\_NON\_BLOCKING**, and the semaphore was not available.

**OS\_ERR\_SCHED\_LOCKED** if calling this function when the scheduler is locked.

`OS_ERR_TIMEOUT` if the semaphore is not signaled within the specified timeout.

### **Returned Value**

The new value of the semaphore count.

### **Notes/Warnings**

1. Semaphores must be created before they are used.

### **Example**

```
OS_SEM SwSem;

void DispTask (void *p_arg)
{
    OS_ERR err;
    CPU_TS ts;

    (void)&p_arg;
    while (DEF_ON) {
        :
        :
        OSSemPend(&SwSem,
                  0,
                  OS_OPT_PEND_BLOCKING,
                  &ts,
                  &err);
        /* Check "err" */
    }
}
```

# OSSemPendAbort ()

```
OS_OBJ_QTY OSSemPendAbort (OS_SEM *p_sem,
                           OS_OPT  opt,
                           OS_ERR  *p_err)
```

| File     | Called from | Code enabled by                               |
|----------|-------------|---|
| OS_SEM.C | Task only   | OS_CFG_SEM_EN and<br>OS_CFG_SEM_PEND_ABORT_EN |

`OSSemPendAbort()` aborts and readies any task currently waiting on a semaphore. This function should be used to fault-abort the wait on the semaphore, rather than to normally signal the semaphore via `OSSemPost()`.

## Arguments

`p_sem` is a pointer to the semaphore for which pend(s) need to be aborted.

`opt` determines the type of abort performed.

|                                    |  |
|------------------------------------|--|
| <code>OS_OPT_PEND_ABORT_1</code>   | Aborts the pend of only the highest-priority task waiting on the semaphore.  |
| <code>OS_OPT_PEND_ABORT_ALL</code> | Aborts the pend of all the tasks waiting on the semaphore.   |
| <code>OS_OPT_POST_NO_SCHED</code>  | Specifies that the scheduler should not be called, even if the pend of a higher-priority task has been aborted. Scheduling will need to occur from another function. Use this option if the task calling <code>OSSemPendAbort()</code> will be doing additional pend aborts, reschedule takes place when finished, and multiple pend aborts are to take effect simultaneously. |
| <code>p_err</code>                 | Is a pointer to a variable that holds an error code. <code>OSSemPendAbort()</code> sets <code>*p_err</code> to one of the following:   |



|                                     |  |
|-------------------------------------|--|
| <code>OS_ERR_NONE</code>            | At least one task waiting on the semaphore was readied and informed of the aborted wait. Check the return value for the number of tasks whose wait on the semaphore was aborted. |
| <code>OS_ERR_OBJ_PTR_NULL</code>    | if <code>p_sem</code> is a NULL pointer.   |
| <code>OS_ERR_OBJ_TYPE</code>        | if <code>p_sem</code> is not pointing to a semaphore.  |
| <code>OS_ERR_OPT_INVALID</code>     | if an invalid option is specified.   |
| <code>OS_ERR_PEND_ABORT_ISR</code>  | This function is called from an ISR.   |
| <code>OS_ERR_PEND_ABORT_NONE</code> | No task was aborted because no task was waiting.   |

### Returned Value

`OSSemPendAbort()` returns the number of tasks made ready to run by this function. Zero indicates that no tasks were pending on the semaphore and therefore, the function had no effect.

### Notes/Warnings

Semaphores must be created before they are used.

### Example

```
OS_SEM SwSem;

void CommTask(void *p_arg)
{
    OS_ERR    err;
    OS_OBJ_QTY  nbr_tasks;

    (void)&p_arg;
    while (DEF_ON) {
        :
        :
        nbr_tasks = OS_SemPendAbort(&SwSem,
                                   OS_OPT_PEND_ABORT_ALL,
                                   &err);

        /* Check "err" */
        :
        :
    }
}
```

# OSSemPost ()

```
OS_SEM_CTR OSemPost (OS_SEM *p_sem,
                    OS_OPT  opt,
                    OS_ERR  *p_err)
```

| File     | Called from | Code enabled by |
|----------|-------------|-----------------|
| OS_SEM.C | Task or ISR | OS_CFG_SEM_EN   |

A semaphore is signaled by calling `OSemPost()`. If the semaphore value is 0 or more, it is incremented, and `OSemPost()` returns to its caller. If tasks are waiting for the semaphore to be signaled, `OSemPost()` removes the highest-priority task pending for the semaphore from the waiting list and makes this task ready to run. The scheduler is then called to determine if the awakened task is now the highest-priority task that is ready to run.

## Arguments

`p_sem` is a pointer to the semaphore.

`opt` determines the type of post performed.

|                                   |   |
|-----------------------------------|---|
| <code>OS_OPT_POST_1</code>        | Post and ready only the highest-priority task waiting on the semaphore.   |
| <code>OS_OPT_POST_ALL</code>      | Post to all tasks waiting on the semaphore. ONLY use this option if the semaphore is used as a signaling mechanism and NEVER when the semaphore is used to guard a shared resource. It does not make sense to tell all tasks that are sharing a resource that they can all access the resource. |
| <code>OS_OPT_POST_NO_SCHED</code> | This option indicates that the caller does not want the scheduler to be called after the post. This option can be used in combination with ONE of the two previous options.   |

Use this option if the task (or ISR) calling `OSSemPost()` will be doing additional, the user does not want to reschedule until all done, and multiple posts are to take effect simultaneously.

`p_err` is a pointer to a variable that holds an error code:

|                                  |   |
|----------------------------------|---|
| <code>OS_ERR_NONE</code>         | if no tasks are waiting on the semaphore. In this case, the return value is also 0. |
| <code>OS_ERR_OBJ_PTR_NULL</code> | if <code>p_sem</code> is a <code>NULL</code> pointer.                               |
| <code>OS_ERR_OBJ_TYPE</code>     | if <code>p_sem</code> is not pointing to a semaphore.                               |
| <code>OS_ERR_SEM_OVF</code>      | if the post would have caused the semaphore counter to overflow.                    |

### **Returned Value**

The current value of the semaphore count

### **Notes/Warnings**

1. Semaphores must be created before they are used.
2. You can also post to a semaphore from an ISR but the semaphore must be used as a signaling mechanism and not to protect a shared resource.

## Example

```
OS_SEM SwSem;

void TaskX (void *p_arg)
{
    OS_ERR      err;
    OS_SEM_CTR  ctr;

    (void)&p_arg;
    while (DEF_ON) {
        :
        :
        ctr = OS_SemPost(&SwSem,
                        OS_OPT_POST_1 + OS_OPT_POST_NO_SCHED,
                        &err);
        /* Check "err" */
        :
        :
    }
}
```

# OSSemSet ( )

```
void OSSemSet (OS_SEM      *p_sem,  
              OS_SEM_CTR  cnt,  
              OS_ERR      *p_err)
```

| File     | Called from | Code enabled by                        |
|----------|-------------|--|
| OS_SEM.C | Task        | OS_CFG_SEM_EN and<br>OS_CFG_SEM_SET_EN |

`OSSemSet()` is used to change the current value of the semaphore count. This function is normally selected when a semaphore is used as a signaling mechanism. `OSSemSet()` can then be used to reset the count to any value. If the semaphore count is already 0, the count is only changed if there are no tasks waiting on the semaphore.

## Arguments

`p_sem` is a pointer to the semaphore that is used as a signaling mechanism.

`cnt` is the desired count that the semaphore should be set to.

`p_err` is a pointer to a variable used to hold an error code:

|                                  |   |
|----------------------------------|---|
| <code>OS_ERR_NONE</code>         | if the count was changed or, not changed, because one or more tasks was waiting on the semaphore. |
| <code>OS_ERR_OBJ_PTR_NULL</code> | if <code>p_sem</code> is a <code>NULL</code> pointer.   |
| <code>OS_ERR_OBJ_TYPE</code>     | if <code>p_sem</code> is not pointing to a semaphore.   |
| <code>OS_ERR_SET_ISR</code>      | if this function was called from an ISR.  |
| <code>OS_ERR_TASK_WAITING</code> | if tasks are waiting on the semaphore.  |

## Returned Value

None

## Notes/Warnings

*Do not* use this function if the semaphore is used to protect a shared resource.

## Example

```
OS_SEM SwSem;

void Task (void *p_arg)
{
    OS_ERR err;

    (void)&p_arg;
    while (DEF_ON) {
        OS_SemSet(&SwSem,          /* Reset the semaphore count */
                0,
                &err);
        /* Check "err" */
        :
        :
    }
}
```

# OSStart()

void OSStart (OS\_ERR \*p\_err)

| File      | Called from       | Code enabled by |
|-----------|-------------------|-----------------|
| OS_CORE.C | Startup code only | N/A             |

OSStart() starts multitasking under μC/OS-III. This function is typically called from startup code after calling OSInit(). OSStart() will not return to the caller. Once μC/OS-III is running, calling OSStart() again will have no effect.

## Arguments

**p\_err** is a pointer to a variable used to hold an error code:

|                     |   |
|---------------------|---|
| OS_ERR_FATAL_RETURN | if we ever return to this function.   |
| OS_ERR_OS_RUNNING   | if the kernel is already running. In other words, if this function has already been called. |

## Returned Value

None

## Notes/Warnings

OSInit() must be called prior to calling OSStart(). OSStart() should only be called once by the application code. However, if calling OSStart() more than once, nothing happens on the second and subsequent calls.

## Example

```
void main (void)
{
    OS_ERR  err;

    :
    :
    OSInit(&err);          /* Initialize  $\mu$ C/OS-III */
    /* Check "err" */
    :
    :
    OSStart(&err);        /* Start Multitasking */
    /* Any code here should NEVER be executed! */
}
```



# OSStartHighRdy ()

void OSStartHighRdy (void)

| File         | Called from | Code enabled by |
|--------------|-------------|-----------------|
| OS_CPU_A.ASM | OSStart()   | N/A             |

OSStartHighRdy() is responsible for starting the highest-priority task that was created prior to calling OSStart().

## Arguments

None

## Returned Values

None

## Notes/Warnings

None

## Example

The pseudocode for OSStartHighRdy() is shown below.

```
void OSStartHighRdy (void)
{
    OSTaskSwHook();                (1)
    SP = OSTCBHighRdyPtr->StkPtr;  (2)
    Pop CPU registers off the task's stack;  (3)
    Return from interrupt;         (4)
}
```

- (1) OSStartHighRdy() must call OSTaskSwHook().

When called, OSTCBCurPtr and OSTCBHighRdyPtr both point to the OS\_TCB of the highest-priority task created.

OSTaskSwHook() should check that OSTCBCurPtr is not equal to OSTCBHighRdyPtr as this is the first time OSTaskSwHook() is called and there is not a task that is switched out.

- (2) Load the CPU stack pointer register with the top-of-stack (TOS) of the task being started. The TOS is found in the `.StkPtr` field of the `OS_TCB`. For convenience, the `.StkPtr` field is the very first field of the `OS_TCB` data structure. This makes it easily accessible from assembly language.
- (3) Pop the registers from the task's stack frame. Recall that the registers should have been placed on the stack frame in the same order as if they were pushed at the beginning of an interrupt service routine.
- (4) Perform a return from interrupt, which starts the task as if it was resumed when returning from a real interrupt.

# OSStatReset ()

void OSStatReset (OS\_ERR \*p\_err)

| File      | Called from     | Code enabled by     |
|-----------|-----------------|---------------------|
| OS_STAT.C | Task Level Only | OS_CFG_STAT_TASK_EN |

OSStatReset() is used to reset statistical variables maintained by μC/OS-III. Specifically, the per-task maximum interrupt disable time, maximum scheduler lock time, maximum amount of time a message takes to reach a task queue, the maximum amount of time it takes a signal to reach a task and more.

## Arguments

**p\_err** is a pointer to a variable used to hold an error code:

- OS\_ERR\_NONE the call was successful.
- OS\_ERR\_STAT\_RESET\_ISR if the call was attempted from an ISR.

## Returned Value

None

## Notes/Warnings

None

## Example

```
void TaskX (void *p_arg)
{
    OS_ERR  err;

    (void)&p_arg;
    while (DEF_ON) {
        :
        :
        OSStatReset(&err);
        /* Check "err" */
        :
        :
    }
}
```

# OSStatTaskCPUUsageInit()

```
void OSStatTaskCPUUsageInit (void)
```

| File      | Called from       | Code enabled by     |
|-----------|-------------------|---------------------|
| OS_STAT.C | Startup code only | OS_CFG_TASK_STAT_EN |

`OSStatTaskCPUUsageInit()` determines the maximum value that a 32-bit counter can reach when no other task is executing. This function must be called when only one task is created in the application and when multitasking has started. This function must be called from the first and only task created by the application.

## Arguments

`p_err` is a pointer to a variable used to hold an error code:

`OS_ERR_NONE` Always returns this value.

## Returned Value

None

## Notes/Warnings

None

## Example

```
void FirstAndOnlyTask (void *p_arg)
{
    :
    :
    #if OS_CFG_TASK_STAT_EN > 0
        OSStatTaskCPUUsageInit(); /* Compute CPU capacity with no task running */
    #endif
    :
    OSTaskCreate(_);             /* Create the other tasks          */
    OSTaskCreate(_);
    :
    while (DEF_ON) {
        :
        :
    }
}
```

# OSStatTaskHook ()

void OSStatTaskHook (void);

| File       | Called from  | Code enabled by |
|------------|--------------|-----------------|
| OS_CPU_C.C | OSStatTask() | Always enabled  |

OSStatTaskHook() is a function called by μC/OS-III's statistic task, OSStatTask(). OSStatTaskHook() is generally implemented by the port implementer for the processor used. This hook allows the port to perform additional statistics for the processor used.

## Arguments

None

## Returned Values

None

## Notes/Warnings

None

## Example

The code below calls an application-specific hook that an application programmer can define. For this, the user can simply set the value of OS\_AppStatTaskHookPtr to point to the desired hook function (see App\_OS\_SetAllHooks() in OS\_APP\_HOOKS.C).

In the example below, OSStatTaskHook() calls App\_OS\_StatTaskHook() if the pointer OS\_AppStatTaskHookPtr is set to that function.

```
void App_OS_StatTaskHook (void)                                /* OS_APP_HOOKS.C    */
{
    /* Your code goes here! */
}

void App_OS_SetAllHooks (void)                                /* OS_APP_HOOKS.C    */
{
    CPU_SR_ALLOC();

    CPU_CRITICAL_ENTER();
    :
    OS_AppStatTaskHookPtr = App_OS_StatTaskHook;
    :
    CPU_CRITICAL_EXIT();
}

void OSStatTaskHook (void)                                    /* OS_CPU_C.C        */
{
    #if OS_CFG_APP_HOOKS_EN > 0u
        if (OS_AppStatTaskHookPtr != (OS_APP_HOOK_VOID)0) { /* Call application hook */
            (*OS_AppStatTaskHookPtr)();
        }
    #endif
}
```

# OSTaskChangePrio()

```
void OSTaskChangePrio (OS_TCB  *p_tcb,  
                      OS_PRIO  prio_new,  
                      OS_ERR   *p_err)
```

| File      | Called from | Code enabled by            |
|-----------|-------------|----------------------------|
| OS_TASK.C | Task        | OS_CFG_TASK_CHANGE_PRIO_EN |

When you creating a task (see `OSTaskCreate()`), you also specify the priority of the task being created. In most cases, it is not necessary to change the priority of the task at run time. However, it is sometimes useful to do so, and `OSTaskChangePrio()` allows this to take place.

If the task is ready to run, `OSTaskChangePrio()` simply changes the position of the task in μC/OS-III's ready list. If the task is waiting on an event, `OSTaskChangePrio()` will change the position of the task in the pend list of the corresponding object, so that the pend list remains sorted by priority.

Because μC/OS-III supports multiple tasks at the same priority, there are no restrictions on the priority that a task can have, except that task priority zero (0) is reserved by μC/OS-III, and priority `OS_PRIO_MAX-1` is used by the idle task.

Note that a task priority cannot be changed from an ISR.

## Arguments

**p\_tcb** is a pointer to the `OS_TCB` of the task for which the priority is being changed. If passing a `NULL` pointer, the priority of the current task is changed.

**prio\_new** is the new task's priority. This value must never be set to `OS_CFG_PRIO_MAX-1`, or higher and you must not use priority 0 since they are reserved for μC/OS-III.

**p\_err** is a pointer to a variable that will receive an error code:

- `OS_ERR_NONE` if the task's priority is changed.
- `OS_ERR_TASK_CHANGE_PRIO_ISR` if attempting to change the task's priority from an ISR.

OS\_ERR\_PRIO\_INVALID

if the priority of the task specified is invalid. By specifying a priority greater than or equal to OS\_PRIO\_MAX-1, or 0.

### Returned Value

None

### Notes/Warnings

None

### Example

```
OS_TCB MyTaskTCB;

void TaskX (void *p_arg)
{
    OS_ERR err;

    while (DEF_ON) {
        :
        :
        OSTaskChangePrio(&MyTaskTCB, /* Change the priority of "MyTask" to 10 */
                        10,
                        &err);
        /* Check "err" */
        :
    }
}
```



# OSTaskCreate ()

```
void OSTaskCreate (OS_TCB      *p_tcb,  
                  CPU_CHAR    *p_name,  
                  OS_TASK_PTR  p_task,  
                  void         *p_arg,  
                  OS_PRIO     prio,  
                  CPU_STK     *p_stk_base,  
                  CPU_STK_SIZE stk_limit,  
                  CPU_STK_SIZE stk_size,  
                  OS_MSG_QTY   q_size,  
                  OS_TICK     time_quanta,  
                  void         *p_ext,  
                  OS_OPT      opt,  
                  OS_ERR      *p_err)
```

| File      | Called from          | Code enabled by |
|-----------|----------------------|-----------------|
| OS_TASK.C | Task or startup code | N/A             |

Tasks must be created in order for μC/OS-III to recognize them as tasks. Create a task by calling `OSTaskCreate()` and provide arguments specifying to μC/OS-III how the task will be managed. Tasks are always created in the ready-to-run state.

Tasks can be created either prior to the start of multitasking (i.e., before calling `OSStart()`), or by a running task. A task cannot be created by an ISR. A task must either be written as an infinite loop, or delete itself once completed. If the task code returns by mistake, μC/OS-III will terminate the task by calling `OSTaskDel((OS_TCB *)0, &err)`. At Micrium, we like the “`while (DEF_ON)`” to implement infinite loops because, by convention, we use a `while` loop when we don’t know how many iterations a loop will do. This is the case of an infinite loop. We use `for` loops when we know how many iterations a loop will do.

Task as an infinite loop:

```
void MyTask (void *p_arg)
{
    /* Local variables                                     */

    /* Do something with 'p_arg'                         */
    /* Task initialization                                */
    while (DEF_ON) { /* Task body, as an infinite loop. */
        :
        :
        /* Must call one of the following services:      */
        /*  OSFlagPend()                                 */
        /*  OSMutexPend()                                */
        /*  OSQPend()                                    */
        /*  OSSemPend()                                  */
        /*  OSTimeDly()                                   */
        /*  OSTimeDlyHMSM()                              */
        /*  OSTaskQPend()                                */
        /*  OSTaskSemPend()                              */
        /*  OSTaskSuspend() (Suspend self)              */
        /*  OSTaskDel() (Delete self)                   */
        :
        :
    }
}
```

Run to completion task:

```
void MyTask (void *p_arg)
{
    OS_ERR err;
    /* Local variables                                     */

    /* Do something with 'p_arg'                         */
    /* Task initialization                                */
    /* Task body (do some work)                         */
    OSTaskDel((OS_TCB *)0, &err);
    /* Check 'err'                                       */
}
```

## Arguments

**p\_tcb** is a pointer to the task's **OS\_TCB** to use. It is assumed that storage for the TCB of the task will be allocated by the user code. Declare a “global” variable as follows, and pass a pointer to this variable to **OSTaskCreate()**:

```
OS_TCB MyTaskTCB;
```

**p\_name** is a pointer to an ASCII string (NUL terminated) to assign a name to the task. The name can be displayed by debuggers or by **μC/Probe**.

**p\_task** is a pointer to the task (i.e., the name of the function).

**p\_arg** is a pointer to an optional data area, which is used to pass parameters to the task when it is created. When **μC/OS-III** runs the task for the first time, the task will think that it was invoked, and passed the argument **p\_arg**. For example, create a generic task that handles an asynchronous serial port. **p\_arg** can be used to pass task information about the serial port it will manage: the port address, baud rate, number of bits, parity, and more. **p\_arg** is the argument received by the task shown below.

```
void MyTask (void *p_arg)
{
    while (DEF_ON) {
        Task code;
    }
}
```

**prio** is the task priority. The lower the number, the higher the priority (i.e., the importance) of the task. If **OS\_CFG\_ISR\_POST\_DEFERRED\_EN** is set to 1, the user may not use priority 0.

Task priority must also have a lower number than **OS\_CFG\_PRIO\_MAX-1**. Priorities 0, 1, **OS\_CFG\_PRIO\_MAX-2** and **OS\_CFG\_PRIO\_MAX-1** are reserved. In other words, a task should have a priority between 2 and **OS\_CFG\_PRIO\_MAX-3**, inclusively.

`p_stk_base` is a pointer to the task's stack base address. The task's stack is used to store local variables, function parameters, return addresses, and possibly CPU registers during an interrupt.

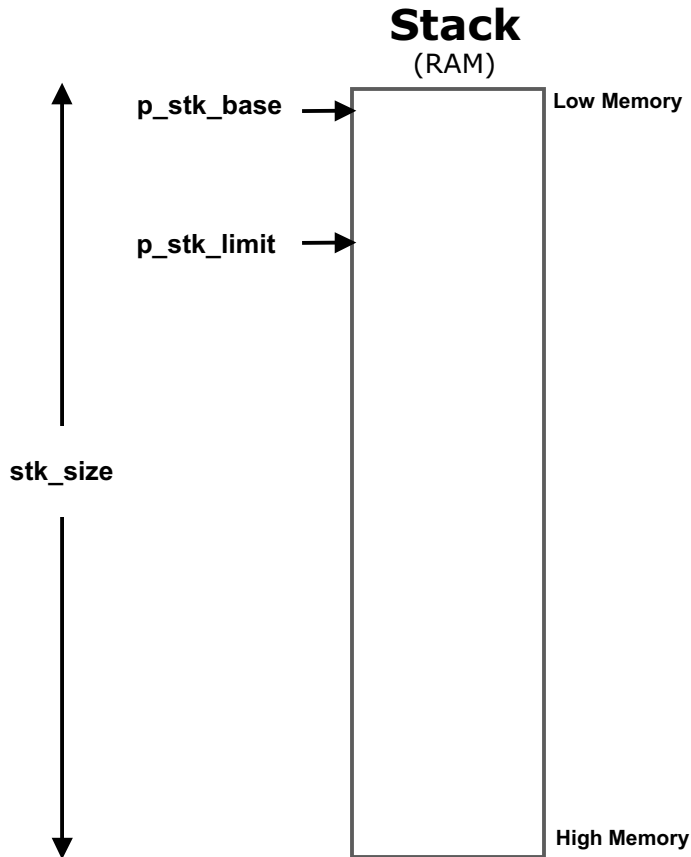

The task stack must be declared as follows:

```
CPU_STK MyTaskStk[xxx];
```

The user would then pass `p_stk_base` the address of the first element of this array or, `&MyTaskStk[0]`. "xxx" represents the size of the stack.

The size of this stack is determined by the task's requirements and the anticipated interrupt nesting (unless the processor has a separate stack just for interrupts). Determining the size of the stack involves knowing how many bytes are required for storage of local variables for the task itself and all nested functions, as well as requirements for interrupts (accounting for nesting).

Note that you can allocate stack space for a task from the heap but, in this case, never delete the task and free the stack space as this can cause the heap to fragment, which is not desirable in embedded systems.

`stk_limit` is used to locate, within the task's stack, a watermark limit that can be used to monitor and ensure that the stack does not overflow.

If the processor does not have hardware stack overflow detection, or this feature is not implemented in software by the port developer, this value may be used for other purposes. For example, some processors have two stacks, a hardware and a software stack. The hardware stack typically keeps track of function call nesting and the software stack is used to pass function arguments. `stk_limit` may be used to set the size of the hardware stack as shown below.

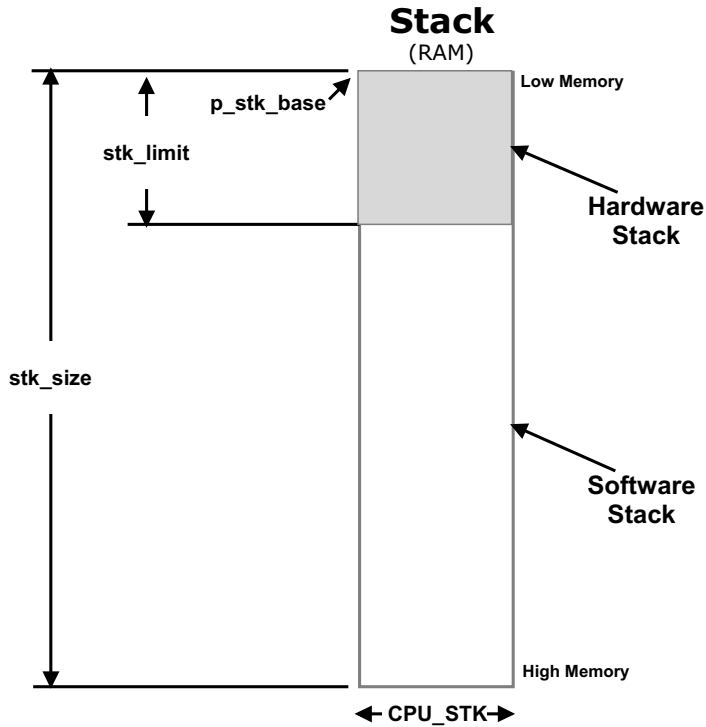

**stk\_size** specifies the size of the task's stack in number of elements. If **CPU\_STK** is set to **CPU\_INT08U** (see **OS\_TYPE.H**), **stk\_size** corresponds to the number of bytes available on the stack. If **CPU\_STK** is set to **CPU\_INT16U**, then **stk\_size** contains the number of 16-bit entries available on the stack. Finally, if **CPU\_STK** is set to **CPU\_INT32U**, **stk\_size** contains the number of 32-bit entries available on the stack.

**q\_size** A  $\mu$ C/OS-III task contains an optional internal message queue (if **OS\_TASK\_Q\_EN** > 0). This argument specifies the maximum number of messages that the task can receive through this message queue. The user may specify that the task is unable to receive messages by setting the argument to 0.

**time\_quanta** the amount of time (in clock ticks) for the time quanta when round robin is enabled. If you specify 0, then the default time quanta will be used which is the tick rate divided by 10.

**p\_ext** is a pointer to a user-supplied memory location (typically a data structure) used as a TCB extension. For example, the user memory can hold the contents of floating-point registers during a context switch.

**opt** contains task-specific options. Each option consists of one bit. The option is selected when the bit is set. The current version of μC/OS-III supports the following options:

- |                                  |  |
|----------------------------------|--|
| <code>OS_OPT_TASK_NONE</code>    | specifies that there are no options.   |
| <code>OS_OPT_TASK_STK_CHK</code> | specifies whether stack checking is allowed for the task.  |
| <code>OS_OPT_TASK_STK_CLR</code> | specifies whether the stack needs to be cleared.   |
| <code>OS_OPT_TASK_SAVE_FP</code> | specifies whether floating-point registers are saved. This option is only valid if the processor has floating-point hardware and the processor-specific code saves the floating-point registers. |

**p\_err** is a pointer to a variable that will receive an error code:

- |                                      |  |
|--------------------------------------|--|
| <code>OS_ERR_NONE</code>             | if the function is successful.   |
| <code>OS_ERR_NAME</code>             | if <code>p_name</code> is a <code>NULL</code> pointer.   |
| <code>OS_ERR_PRIO_INVALID</code>     | if <code>prio</code> is higher than the maximum value allowed (i.e., <code>&gt; OS_PRIO_MAX-1</code> ). Also, if the user set <code>OS_CFG_ISR_POST_DEFERRED_EN</code> to 1 and tried to use priority 0. |
| <code>OS_ERR_STK_INVALID</code>      | if specifying a <code>NULL</code> pointer for <code>p_stk_base</code> .  |
| <code>OS_ERR_STK_SIZE_INVALID</code> | if specifying a stack size smaller than what is currently specified by <code>OS_CFG_STK_SIZE_MIN</code> (see the <code>OS_CFG.H</code> ).  |
| <code>OS_ERR_TASK_CREATE_ISR</code>  | if attempting to create the task from an ISR.  |
| <code>OS_ERR_TASK_INVALID</code>     | if specifying a <code>NULL</code> pointer for <code>p_task</code>  |
| <code>OS_ERR_TCB_INVALID</code>      | if specifying a <code>NULL</code> pointer for <code>p_tcb</code> .   |

### **Returned Value**

None

### **Notes/Warnings**

1. The stack must be declared with the CPU\_STK type.
2. A task must always invoke one of the services provided by  $\mu$ C/OS-III to wait for time to expire, suspend the task, or wait on an object (wait on a message queue, event flag, mutex, semaphore, a signal or a message to be sent directly to the task). This allows other tasks to gain control of the CPU.
3. Do not use task priorities 0, 1, OS\_PRIO\_MAX-2 and OS\_PRIO\_MAX-1 because they are reserved for use by  $\mu$ C/OS-III.

### **Example**

OSTaskCreate() can be called from main() (in C), or a previously created task.



```
OS_TCB MyTaskTCB; /* (1) Storage for task's TCB */
CPU_STK MyTaskStk[200];

void MyTask (void *p_arg) /* (3) The address of the task is its name */
{
    while (DEF_ON) {
        /* Wait for an event */
        /* My task body */
    }
}

void SomeCode (void)
{
    OS_ERR err;
    :
    :
    OSTaskCreate (&MyTaskTCB, /* (1) Address of TCB assigned to the task */
                 "My Task", /* (2) Name you want to give the task */
                 MyTask, /* (3) Address of the task itself */
                 (void *)0, /* (4) "p_arg" is not used */
                 12, /* (5) Priority you want to assign to the task */
                 &MyTaskStk[0], /* (6) Base address of task's stack */
                 10, /* (7) Watermark limit for stack growth */
                 200, /* (8) Stack size in number of CPU_STK elements */
                 5, /* (9) Size of task message queue */
                 10, /* (10) Time quanta (in number of ticks) */
                 (void *)0, /* (11) Extension pointer is not used */
                 OS_OPT_TASK_STK_CHK + OS_OPT_TASK_STK_CLR, /* (12) Options */
                 &err); /* (13) Error code */
    /* Check "err" (14) */
    :
    :
}
```

- (1) In order to create a task, allocate storage for a TCB and pass a pointer to this TCB to `OSTaskCreate()`.
- (2) Assign an ASCII name to the task by passing a pointer to an ASCII string. The ASCII string may be allocated in code space (i.e., ROM), or data space (i.e., RAM). In either case, it is assumed that the code can access that memory.
- (3) Pass the address of the task to `OSTaskCreate()`. In C, the address of a function is simply the name of the function.

- (4) To provide additional data to `MyTask()`, simply pass a pointer to such data. In this case, `MyTask()` did not need such data and therefore, a `NULL` pointer is passed.
- (5) The user must assign a priority to the task. The priority specifies the importance of this task with respect to other tasks. A low-priority value indicates a high priority. Priority 0 is the highest priority (reserved for an internal task) and a priority up to `OS_PRIO_MAX-2` can be specified (see `OS_CFG.H`). Note that `OS_PRIO_MAX-1` is also reserved for an internal task, the idle task.
- (6) The next argument specifies the “base address” of the task’s stack. In this case, it is simply the base address of the array `MyTaskStk[ ]`. Note that it is possible to simply specify the name of the array. I prefer to make it clear by writing `&MyTaskStk[0]`.
- (7) Set the watermark limit for stack growth. If the processor port does not use this field then either set this value to 0.
- (8) `μC/OS-III` also needs to know the size of the stack for the task. This allows `μC/OS-III` to perform stack checking at run time.
- (9) `μC/OS-III` allows tasks or ISRs to send messages directly to a task. This argument specifies how many such messages can be received by this task.
- (10) This argument specifies how much time (in number of ticks) this task will run on the CPU before `μC/OS-III` will force the CPU away from this task and run the next task at the same priority (if there are more than one task at the same priority that is ready to run).
- (11) `μC/OS-III` allows the user to “extend” the capabilities of the TCB by allowing passing a pointer to some memory location that could contain additional information about the task. For example, there may be a CPU that supports floating-point math and the user would likely need to save the floating-point registers during a context switch. This pointer could point to the storage area for these registers.

- (12) When creating a task, options must be specified. Specifically, such options as, whether the stack of the task will be cleared (i.e., filled with 0x00) when the task is created (`OS_OPT_TASK_STK_CLR`), whether μC/OS-III will be allowed to check for stack usage (`OS_OPT_TASK_STK_CHK`), whether the CPU supports floating-point math, and whether the task will make use of the floating-point registers and therefore need to save and restore them during a context switch (`OS_OPT_TASK_SAVE_FP`). The options are additive.
  
- (13) Most of μC/OS-III's services return an error code indicating the outcome of the call. The error code is always returned as a pointer to a variable of type `OS_ERR`. The user must allocate storage for this variable prior to calling `OSTaskCreate()`. By the way, a pointer to an error variable is always the last argument, which makes it easy to remember.
  
- (14) It is highly recommended that the user examine the error code whenever calling a μC/OS-III function. If the call is successful, the error code will always be `OS_ERR_NONE`. If the call is not successful, the returned code will indicate the reason for the failure (see `OS_ERR_???` in `OS.H`).

# OSTaskCreateHook ()

```
void OSTaskCreateHook (OS_TCB *p_tcb)
```

| File       | Called from         | Code enabled by |
|------------|---------------------|-----------------|
| OS_CPU_C.C | OSTaskCreate() ONLY | N/A             |

This function is called by `OSTaskCreate()` just before adding the task to the ready list. When `OSTaskCreateHook()` is called, all of the `OS_TCB` fields are assumed to be initialized. `OSTaskCreateHook()` is called after initializing the `OS_TCB` fields and setting up the stack frame for the task, before the task is placed in the ready list.

`OSTaskCreateHook()` is part of the CPU port code and this function *must not* be called by the application code. `OSTaskCreateHook()` is actually used by the  $\mu$ C/OS-III port developer.

Use this hook to initialize and store the contents of floating-point registers, MMU registers, or anything else that can be associated with a task. Typically, store this additional information in memory allocated by the application.

## Arguments

`p_tcb` is a pointer to the TCB of the task being created. Note that the `OS_TCB` has been validated by `OSTaskCreate()` and is guaranteed to not be a `NULL` pointer when `OSTaskCreateHook()` is called.

## Returned Value

None

## Notes/Warnings

*Do not* call this function from the application.

## Example

The code below calls an application-specific hook that the application programmer can define. The user can simply set the value of `OS_AppTaskCreateHookPtr` to point to the desired hook function as shown in the example. `OSTaskCreate()` calls

`OSTaskCreateHook()` which in turns calls `App_OS_TaskCreateHook()` through `OS_AppTaskCreateHookPtr`. As can be seen, when called, the application hook is passed the address of the `OS_TCB` of the newly created task.

```
void App_OS_TaskCreateHook (OS_TCB *p_tcb)           /* OS_APP_HOOKS.C      */
{
    /* Your code goes here! */
}

void App_OS_SetAllHooks (void)                       /* OS_APP_HOOKS.C      */
{
    CPU_SR_ALLOC();

    CPU_CRITICAL_ENTER();
    :
    OS_AppTaskCreateHookPtr = App_OS_TaskCreateHook;
    :
    CPU_CRITICAL_EXIT();
}

void OSTaskCreateHook (OS_TCB *p_tcb)                /* OS_CPU_C.C          */
{
    #if OS_CFG_APP_HOOKS_EN > 0u
        if (OS_AppTaskCreateHookPtr != (OS_APP_HOOK_TCB)0) { /* Call application hook */
            (*OS_AppTaskCreateHookPtr)(p_tcb);
        }
    #endif
}
```

# OSTaskDel ()

```
void OSTaskDel (OS_TCB *p_tcb,
               OS_ERR *p_err)
```

| File      | Called from | Code enabled by    |
|-----------|-------------|--------------------|
| OS_TASK.C | Task        | OS_CFG_TASK_DEL_EN |

When a task is no longer needed, it can be deleted. Deleting a task does not mean that the code is removed, but that the task code is no longer managed by  $\mu$ C/OS-III. `OSTaskDel()` can be used when creating a task that will only run once. In this case, the task must not return but instead call `OSTaskDel((OS_TCB *)0, &err)`, specifying to  $\mu$ C/OS-III to delete the currently running task.

A task may also delete another task by specifying to `OSTaskDel()` the address of the `OS_TCB` of the task to delete.

Once a task is deleted, its `OS_TCB` and stack may be reused to create another task. This assumes that the task's stack requirement of the new task is satisfied by the stack size of the deleted task.

Even though  $\mu$ C/OS-III allows the user to delete tasks at run time, it is recommend that such actions be avoided. Why? Because a task can "own" resources that are shared with other tasks. Deleting the task that owns resource(s) without first relinquishing the resources could lead to strange behaviors and possible deadlocks.

## Arguments

**p\_tcb** is a pointer to the TCB of the task to delete or, a `NULL` pointer for the calling task to delete itself. If deleting the calling task, the scheduler will be invoked so that the next highest-priority task is executed.

**p\_err** is a pointer to a variable that will receive an error code:

|                                   |   |
|-----------------------------------|---|
| <code>OS_ERR_NONE</code>          | if the desired task was deleted (unless the task deleted itself in which case there are no errors to return). |
| <code>OS_ERR_TASK_DEL_IDLE</code> | if attempting to delete the ilde task.  |

|                                      |  |
|--------------------------------------|--|
| <code>OS_ERR_TASK_DEL_ISR</code>     | if calling <code>OSTaskDel()</code> from an ISR.   |
| <code>OS_ERR_TASK_DEL_INVALID</code> | if attempting to delete the ISR Handler task while <code>OS_CFG_ISR_POST_DEFERRED_EN</code> is set to 1. |

### Returned Value

None

### Notes/Warnings

1. `OSTaskDel()` verifies that the user is not attempting to delete the  $\mu$ C/OS-III idle task and the ISR handler task.
2. Be careful when deleting a task that owns resources.

### Example

```
OS_TCB MyTaskTCB;

void TaskX (void *p_arg)
{
    OS_ERR err;

    while (DEF_ON) {
        :
        :
        OSTaskDel(&MyTaskTCB,
                 &err);
        /* Check "err" */
        :
        :
    }
}
```

---

## OSTaskDelHook ()

```
void OSTaskDelHook (OS_TCB *p_tcb);
```

| File       | Called from      | Code enabled by |
|------------|------------------|-----------------|
| OS_CPU_C.C | OSTaskDel() ONLY | N/A             |

This function is called by `OSTaskDel()` after the task is removed from the ready list or any pend list.

Use this hook to deallocate storage assigned to the task.

`OSTaskDelHook()` is part of the CPU port code and this function *must not* be called by the application code. `OSTaskDelHook()` is actually used by the  $\mu$ C/OS-III port developer.

### Arguments

`p_tcb` is a pointer to the TCB of the task being created. Note that the `OS_TCB` has been validated by `OSTaskDel()` and is guaranteed to not be a `NULL` pointer when `OSTaskDelHook()` is called.

### Returned Value

None

### Notes/Warnings

*Do not* call this function from the application.

### Example

The code below calls an application-specific hook that the application programmer can define. The user can simply set the value of `OS_AppTaskDelHookPtr` to point to the desired hook function. `OSTaskDel()` calls `OSTaskDelHook()` which in turns calls `App_OS_TaskDelHook()` through `OS_AppTaskDelHookPtr`. As can be seen, when called, the application hook is passed the address of the `OS_TCB` of the task being deleted.



```
void App_OS_TaskDelHook (OS_TCB *p_tcb)                /* OS_APP_HOOKS.C    */
{
    /* Your code goes here! */
}

void App_OS_SetAllHooks (void)                        /* OS_APP_HOOKS.C    */
{
    CPU_SR_ALLOC();

    CPU_CRITICAL_ENTER();
    :
    OS_AppTaskDelHookPtr = App_OS_TaskDelHook;
    :
    CPU_CRITICAL_EXIT();
}

void OSTaskDelHook (OS_TCB *p_tcb)                   /* OS_CPU_C.C        */
{
    #if OS_CFG_APP_HOOKS_EN > 0u
        if (OS_AppTaskDelHookPtr != (OS_APP_HOOK_TCB)0) { /* Call application hook */
            (*OS_AppTaskDelHookPtr)(p_tcb);
        }
    #endif
}
```

# OSTaskQPend()

```
void *OSTaskQPend (OS_TICK      timeout,
                  OS_OPT       opt,
                  OS_MSG_SIZE  *p_msg_size,
                  CPU_TS       *p_ts,
                  OS_ERR       *p_err)
```

| File      | Called from | Code enabled by                       |
|-----------|-------------|---------------------------------------|
| OS_TASK.C | Task        | OS_CFG_TASK_Q_EN and<br>OS_CFG_MSG_EN |

**OSTaskQPend()** allows a task to receive messages directly from an ISR or another task, without going through an intermediate message queue. In fact, each task has a built-in message queue if the configuration constant **OS\_TASK\_Q\_EN** is set to 1. The messages received are pointer-sized variables, and their use is application specific. If at least one message is already present in the message queue when **OSTaskQPend()** is called, the message is retrieved and returned to the caller.

If no message is present in the task's message queue and **OS\_OPT\_PEND\_BLOCKING** is specified for the **opt** argument, **OSTaskQPend()** suspends the current task (assuming the scheduler is not locked) until either a message is received, or a user-specified timeout expires. A pended task that is suspended with **OSTaskSuspend()** can receive messages. However, the task remains suspended until it is resumed by calling **OSTaskResume()**.

If no message is present in the task's message queue and **OS\_OPT\_PEND\_NON\_BLOCKING** is specified for the **opt** argument, **OSTaskQPend()** returns to the caller with an appropriate error code and returns a **NULL** pointer.

## Arguments

**timeout** allows the task to resume execution if a message is not received from a task or an ISR within the specified number of clock ticks. A timeout value of 0 indicates that the task wants to wait forever for a message. The timeout value is not synchronized with the clock tick. The timeout count starts decrementing on the next clock tick, which could potentially occur immediately.

**opt** determines whether or not the user wants to block if a message is not available in the task's queue. This argument must be set to either:

`OS_OPT_PEND_BLOCKING`, or

`OS_OPT_PEND_NON_BLOCKING`

Note that the timeout argument should be set to 0 when `OS_OPT_PEND_NON_BLOCKING` is specified, since the timeout value is irrelevant using this option.

**p\_msg\_size** is a pointer to a variable that will receive the size of the message.

**p\_ts** is a pointer to a timestamp indicating when the task's queue was posted, or the pend aborted. If passing a `NULL` pointer (i.e., `(CPU_TS *)0`), the timestamp will not be returned. In other words, passing a `NULL` pointer is valid and indicates that the timestamp is not necessary.

A timestamp is useful when the task must know when the task message queue was posted, or how long it took for the task to resume after the task message queue was posted. In the latter case, call `OS_TS_GET()` and compute the difference between the current value of the timestamp and `*p_ts`. In other words:

```
delta = OS_TS_GET() - *p_ts;
```

**p\_err** is a pointer to a variable used to hold an error code.

|                                      |   |
|--------------------------------------|---|
| <code>OS_ERR_NONE</code>             | if a message is received.   |
| <code>OS_ERR_PEND_ABORT</code>       | if the pend was aborted because another task called <code>OSTaskQPendAbort()</code> .   |
| <code>OS_ERR_PEND_ISR</code>         | if calling this function from an ISR.   |
| <code>OS_ERR_PEND_WOULD_BLOCK</code> | if calling this function with the <code>opt</code> argument set to <code>OS_OPT_PEND_NON_BLOCKING</code> and no message is in the task's message queue. |
| <code>OS_ERR_SCHED_LOCKED</code>     | if calling this function when the scheduler is locked and the user wanted to block.   |

`OS_ERR_TIMEOUT` if a message is not received within the specified timeout.

### Returned Value

The message if no error or a `NULL` pointer upon error. Examine the error code since it is possible to send `NULL` pointer messages. In other words, a `NULL` pointer does not mean an error occurred. `*p_err` must be examined to determine the reason for the error.

### Notes/Warnings

Do not call `OSTaskQPend()` from an ISR.

### Example

```
void CommTask (void *p_arg)
{
    OS_ERR      err;
    void        *p_msg;
    OS_MSG_SIZE msg_size;
    CPU_TS      ts;

    (void)&p_arg;
    while (DEF_ON) {
        :
        :
        p_msg = OSTaskQPend(100,
                           OS_OPT_PEND_BLOCKING,
                           &msg_size,
                           &ts,
                           &err);

        /* Check "err" */
        :
        :
    }
}
```

# OSTaskQPendAbort()

```
CPU_BOOLEAN OSTaskQPendAbort (OS_TCB *p_tcb,  
                               OS_OPT  opt,  
                               OS_ERR  *p_err)
```

| File   | Called from | Code enabled by                                     |
|--------|-------------|---|
| OS_Q.C | Task        | OS_CFG_TASK_Q_EN and<br>OS_CFG_TASK_Q_PEND_ABORT_EN |

OSTaskQPendAbort() aborts and readies a task currently waiting on its built-in message queue. This function should be used to fault-abort the wait on the task's message queue, rather than to normally signal the message queue via OSTaskQPost().

## Arguments

**p\_tcb** is a pointer to the task for which the pend needs to be aborted. Note that it doesn't make sense to pass a NULL pointer or the address of the calling task's TCB since, by definition, the calling task cannot be pending.

**opt** provides options for this function.

|                      |   |
|----------------------|---|
| OS_OPT_POST_NONE     | No option specified.  |
| OS_OPT_POST_NO_SCHED | specifies that the scheduler should not be called even if the pend of a higher priority task has been aborted. Scheduling will need to occur from another function. Use this option if the task calling OSTaskQPendAbort() will do additional pend aborts, rescheduling will take place when completed, and multiple pend aborts should take effect simultaneously. |

**p\_err** is a pointer to a variable that holds an error code:

|                       |   |
|-----------------------|---|
| OS_ERR_NONE           | the task was readied by another task and it was informed of the aborted wait. |
| OS_ERR_PEND_ABORT_ISR | if called from an ISR   |

|                                     |  |
|-------------------------------------|--|
| <code>OS_ERR_PEND_ABORT_NONE</code> | if the task was not pending on the task's message queue.   |
| <code>OS_ERR_PEND_ABORT_SELF</code> | if <code>p_tcb</code> is a <code>NULL</code> pointer. The user is attempting to pend abort the calling task which makes no sense as the caller, by definition, is not pending. |

### Returned Value

`OSTaskQPendAbort()` returns `DEF_TRUE` if the task was made ready to run by this function. `DEF_FALSE` indicates that the task was not pending, or an error occurred.

### Notes/Warnings

None

### Example

```
OS_TCB  CommRxTaskTCB;

void CommTask (void *p_arg)
{
    OS_ERR      err;
    CPU_BOOLEAN aborted;

    (void)&p_arg;
    while (DEF_ON) {
        :
        :
        aborted = OSTaskQPendAbort(&CommRxTaskTCB,
                                   OS_OPT_POST_NONE,
                                   &err);

        /* Check "err" */
        :
        :
    }
}
```

# OSTaskQPost ()

```
void OSTaskQPost (OS_TCB      *p_tcb,  
                 void         *p_void,  
                 OS_MSG_SIZE  msg_size,  
                 OS_OPT       opt,  
                 OS_ERR       *p_err)
```

| File   | Called from | Code enabled by                       |
|--------|-------------|---------------------------------------|
| os_q.c | Task or ISR | OS_CFG_TASK_Q_EN and<br>OS_CFG_MSG_EN |

**OSTaskQPost ()** sends a message to a task through its local message queue. A message is a pointer-sized variable, and its use is application specific. If the task's message queue is full, an error code is returned to the caller. In this case, **OSTaskQPost ()** immediately returns to its caller, and the message is not placed in the message queue.

If the task receiving the message is waiting for a message to arrive, it will be made ready to run. If the receiving task has a higher priority than the task sending the message, the higher-priority task resumes, and the task sending the message is suspended; that is, a context switch occurs. A message can be posted as first-in first-out (FIFO), or last-in-first-out (LIFO), depending on the value specified in the **opt** argument. In either case, scheduling occurs unless **opt** is set to **OS\_OPT\_POST\_NO\_SCHED**.

## Arguments

**p\_tcb** is a pointer to the TCB of the task. Note that it is possible to post a message to the calling task (i.e., self) by specifying a **NULL** pointer, or the address of its TCB.

**p\_void** is the actual message sent to the task. **p\_void** is a pointer-sized variable and its meaning is application specific.

**msg\_size** specifies the size of the message posted (in number of bytes).

**opt** determines the type of POST performed. Of course, it does not make sense to post LIFO and FIFO simultaneously, so these options are exclusive:

|                                    |  |
|------------------------------------|--|
| <code>OS_OPT_POST_FIFO</code>      | POST message to task, or place at the end of the queue if the task is not waiting for messages.  |
| <code>OS_OPT_POST_LIFO</code>      | POST message to task, or place at the front of the queue if the task is not waiting for messages.  |
| <code>OS_OPT_POST_NO_SCHED</code>  | Do not call the scheduler after the post and therefore the caller is resumed.<br>Use this option if the task (or ISR) calling <code>OSTaskQPost()</code> will be doing additional posts, the user does not want to reschedule until all done, and multiple posts are to take effect simultaneously. <code>p_err</code> is a pointer to a variable that will contain an error code returned by this function. |
| <code>OS_ERR_NONE</code>           | if the call was successful and the message was posted to the task's message queue.   |
| <code>OS_ERR_MSG_POOL_EMPTY</code> | if running out of <code>OS_MSG</code> to hold the message being posted.  |
| <code>OS_ERR_Q_MAX</code>          | if the task's message queue is full and cannot accept more messages.   |

**Returned Value**

None

**Notes/Warnings**

None



## Example

```
OS_TCB      CommRxTaskTCB;
CPU_INT08U  CommRxBuf[100];

void CommTaskRx (void *p_arg)
{
    OS_ERR  err;

    (void)&p_arg;
    while (DEF_ON) {
        :
        OSTaskQPost(&CommRxTaskTCB,
                    (void *)&CommRxBuf[0],
                    sizeof(CommRxBuf),
                    OS_OPT_POST_FIFO,
                    &err);
        /* Check "err" */
        :
    }
}
```

# OSTaskRegGet ( )

```
OS_REG OSTaskRegGet (OS_TCB      *p_tcb,
                    OS_REG_ID   id,
                    OS_ERR      *p_err)
```

| File      | Called from | Code enabled by              |
|-----------|-------------|------------------------------|
| OS_TASK.C | Task        | OS_CFG_TASK_REG_TBL_SIZE > 0 |

μC/OS-III allows the user to store task-specific values in task registers. Task registers are different than CPU registers and are used to save such information as “errno,” which are common in software components. Task registers can also store task-related data to be associated with the task at run time such as I/O register settings, configuration values, etc. A task may have as many as `OS_CFG_TASK_REG_TBL_SIZE` registers, and all registers have a data type of `OS_REG`. However, `OS_REG` can be declared at compile time (see `OS_TYPE.H`) to be nearly anything (8-, 16-, 32-, 64-bit signed or unsigned integer, or floating-point).

As shown below, a task register is changed by calling `OSTaskRegSet ( )` and read by calling `OSTaskRegGet ( )`. The desired task register is specified as an argument to these functions and can take a value between 0 and `OS_CFG_TASK_REG_TBL_SIZE-1`.

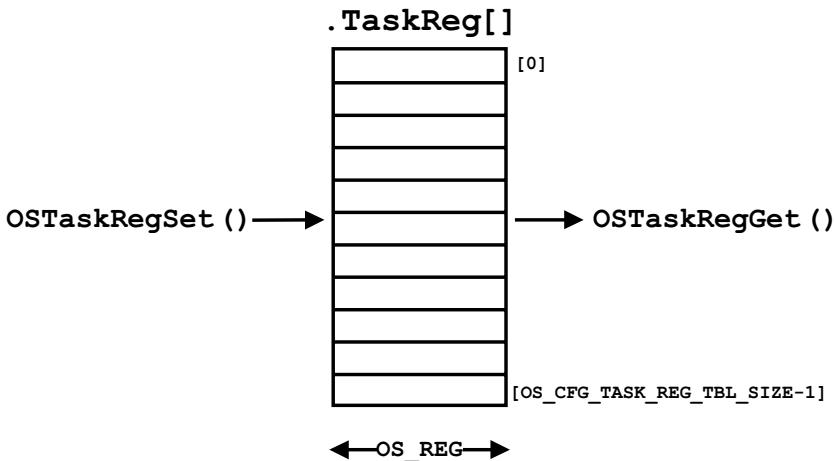

### Arguments

**p\_tcb** is a pointer to the TCB of the task the user is receiving a task-register value from. A NULL pointer indicates that the user wants the value of a task register of the calling task.

**id** is the identifier of the task register and valid values are from 0 to `OS_CFG_TASK_REG_TBL_SIZE-1`.

**p\_err** is a pointer to a variable that will contain an error code returned by this function.

|                                    |  |
|------------------------------------|--|
| <code>OS_ERR_NONE</code>           | if the call was successful and the function returned the value of the desired task register. |
| <code>OS_ERR_REG_ID_INVALID</code> | if a valid task register identifier is not specified.  |

### Returned Value

The current value of the task register.

### Notes/Warnings

None

### Example

```
OS_TCB MyTaskTCB;

void TaskX (void *p_arg)
{
    OS_ERR  err;
    OS_REG  reg;

    while (DEF_ON) {
        :
        reg = OSTaskRegGet(&MyTaskTCB,
                          5,
                          &err);
        /* Check "err" */
        :
    }
}
```

# OSTaskRegSet ( )

```
void OSTaskRegSet (OS_TCB      *p_tcb,
                  OS_REG_ID   id,
                  OS_REG      value,
                  OS_ERR      *p_err)
```

| File      | Called from | Code enabled by              |
|-----------|-------------|------------------------------|
| OS_TASK.C | Task        | OS_CFG_TASK_REG_TBL_SIZE > 0 |

µC/OS-III allows the user to store task-specific values in task registers. Task registers are different than CPU registers and are used to save such information as “errno,” which are common in software components. Task registers can also store task-related data to be associated with the task at run time such as I/O register settings, configuration values, etc. A task may have as many as `OS_CFG_TASK_REG_TBL_SIZE` registers, and all registers have a data type of `OS_REG`. However, `OS_REG` can be declared at compile time to be nearly anything (8-, 16-, 32-, 64-bit signed or unsigned integer, or floating-point).

As shown below, a task register is changed by calling `OSTaskRegSet()`, and read by calling `OSTaskRegGet()`. The desired task register is specified as an argument to these functions and can take a value between 0 and `OS_CFG_TASK_REG_TBL_SIZE-1`.

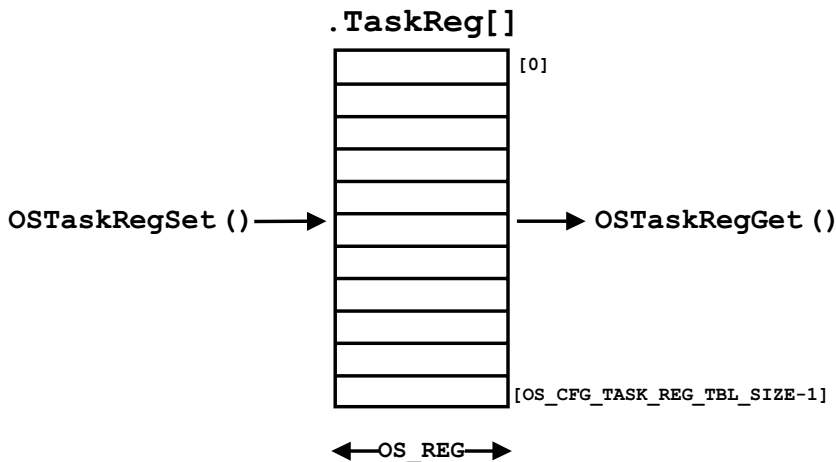

### Arguments

**p\_tcb** is a pointer to the TCB of the task you are setting. A `NULL` pointer indicates that the user wants to set the value of a task register of the calling task.

**id** is the identifier of the task register and valid values are from 0 to `OS_CFG_TASK_REG_TBL_SIZE-1`.

**value** is the new value of the task register specified by **id**.

**p\_err** is a pointer to a variable that will contain an error code returned by this function.

|                                    |  |
|------------------------------------|--|
| <code>OS_ERR_NONE</code>           | if the call was successful, and the function set the value of the desired task register. |
| <code>OS_ERR_REG_ID_INVALID</code> | if a valid task register identifier is not specified.                                    |

### Returned Value

None

### Notes/Warnings

None

### Example

```
OS_TCB MyTaskTCB;

void TaskX (void *p_arg)
{
    OS_ERR err;

    while (DEF_ON) {
        :
        reg = OSTaskRegSet(&MyTaskTCB,
                           5,
                           23,
                           &err);
        /* Check "err" */
        :
    }
}
```

# OSTaskReturnHook ()

```
void OSTaskReturnHook (void);
```

| File       | Called from          | Code enabled by |
|------------|----------------------|-----------------|
| OS_CPU_C.C | OS_TaskReturn() ONLY | N/A             |

This function is called by `OS_TaskReturn()`. `OS_TaskReturn()` is called if the user accidentally returns from the task code. In other words, the task should either be implemented as an infinite loop and never return, or the task must call `OSTaskDel((OS_TCB *)0, &err)` to delete itself to prevent it from exiting.

`OSTaskReturnHook()` is part of the CPU port code and this function *must not* be called by the application code. `OSTaskReturnHook()` is actually used by the  $\mu$ C/OS-III port developer.

Note that after calling `OSTaskReturnHook()`, `OS_TaskReturn()` will actually delete the task by calling:

```
OSTaskDel((OS_TCB *)0,
          &err)
```

## Arguments

`p_tcb` is a pointer to the TCB of the task that is not behaving as expected. Note that the `OS_TCB` is validated by `OS_TaskReturn()`, and is guaranteed to not be a NULL pointer when `OSTaskReturnHook()` is called.

## Returned Value

None

## Notes/Warnings

*Do not* call this function from the application.

## Example

The code below calls an application-specific hook that the application programmer can define. For this, the user can simply set the value of `OS_AppTaskReturnHookPtr` to point to the desired hook function as shown in the example. If a task returns and forgets to call

`OSTaskDel((OS_TCB *)0, &err)` then `μC/OS-III` will call `OSTaskReturnHook()` which in turns calls `App_OS_TaskReturnHook()` through `OS_AppTaskReturnHookPtr`. When called, the application hook is passed the address of the `OS_TCB` of the task returning.

```
void App_OS_TaskReturnHook (OS_TCB *p_tcb)          /* OS_APP_HOOKS.C      */
{
    /* Your code goes here! */
}

void App_OS_SetAllHooks (void)                    /* OS_APP_HOOKS.C      */
{
    CPU_SR_ALLOC();

    CPU_CRITICAL_ENTER();
    :
    OS_AppTaskReturnHookPtr = App_OS_TaskReturnHook;
    :
    CPU_CRITICAL_EXIT();
}

void OSTaskReturnHook (OS_TCB *p_tcb)            /* OS_CPU_C.C          */
{
    #if OS_CFG_APP_HOOKS_EN > 0u
        if (OS_AppTaskReturnHookPtr != (OS_APP_HOOK_TCB)0) { /* Call application hook */
            (*OS_AppTaskReturnHookPtr)(p_tcb);
        }
    #endif
}
```

# OSTaskResume ( )

```
void OSTaskResume (OS_TCB *p_tcb,
                  OS_ERR *p_err)
```

| File      | Called from | Code enabled by        |
|-----------|-------------|------------------------|
| OS_TASK.C | Task        | OS_CFG_TASK_SUSPEND_EN |

**OSTaskResume()** resumes a task suspended through the **OSTaskSuspend()** function. In fact, **OSTaskResume()** is the only function that can unsuspend a suspended task. Obviously, the suspended task can only be resumed by another task. If the suspended task is also waiting on another kernel object such as an event flag, semaphore, mutex, message queue etc., the suspension will simply be lifted (i.e., removed), but the task will continue waiting for the object.

The user can “nest” suspension of a task by calling **OSTaskSuspend()** and therefore must call **OSTaskResume()** an equivalent number of times to resume such a task. In other words, if suspending a task five times, it is necessary to unsuspend the same task five times to remove the suspension of the task.

## Arguments

**p\_tcb** is a pointer to the TCB of the task that is resuming. A **NULL** pointer is not a valid value as one cannot resume the calling task because, by definition, the calling task is running and is not suspended.

**p\_err** is a pointer to a variable that will contain an error code returned by this function.

|                                  |  |
|----------------------------------|--|
| <b>OS_ERR_NONE</b>               | if the call was successful and the desired task is resumed.  |
| <b>OS_ERR_TASK_RESUME_ISR</b>    | if calling this function from an ISR.  |
| <b>OS_ERR_TASK_RESUME_SELF</b>   | if passing a <b>NULL</b> pointer for <b>p_tcb</b> . It is not possible to resume the calling task since, if suspended, it cannot be executing. |
| <b>OS_ERR_TASK_NOT_SUSPENDED</b> | if the task attempting to be resumed is not suspended.   |



### **Returned Value**

None

### **Notes/Warnings**

None

### **Example**

```
OS_TCB  TaskY;

void TaskX (void *p_arg)
{
    OS_ERR err;

    while (DEF_ON) {
        :
        :
        OSTaskResume(&TaskY,
                    &err);          /* Resume suspended task      */
        /* Check "err" */
        :
        :
    }
}
```

# OSTaskSemPend()

```
OS_SEM_CTR OSTaskSemPend (OS_TICK  timeout,
                          OS_OPT    opt,
                          CPU_TS    *p_ts,
                          OS_ERR    *p_err)
```

| File      | Called from | Code enabled by |
|-----------|-------------|-----------------|
| OS_TASK.C | Task        | Always enabled  |

`OSTaskSemPend()` allows a task to wait for a signal to be sent by another task or ISR without going through an intermediate object such as a semaphore. If the task was previously signaled when `OSTaskSemPend()` is called then, the caller resumes.

If no signal was received by the task and `OS_OPT_PEND_BLOCKING` is specified for the `opt` argument, `OSTaskSemPend()` suspends the current task (assuming the scheduler is not locked) until either a signal is received, or a user-specified timeout expires. A pending task suspended with `OSTaskSuspend()` can receive signals. However, the task remains suspended until it is resumed by calling `OSTaskResume()`.

If no signals were sent to the task and `OS_OPT_PEND_NON_BLOCKING` was specified for the `opt` argument, `OSTaskSemPend()` returns to the caller with an appropriate error code and returns a signal count of 0.

## Arguments

**timeout** allows the task to resume execution if a signal is not received from a task or an ISR within the specified number of clock ticks. A timeout value of 0 indicates that the task wants to wait forever for a signal. The timeout value is not synchronized with the clock tick. The timeout count starts decrementing on the next clock tick, which could potentially occur immediately.

**opt** determines whether the user wants to block or not, if a signal was not sent to the task. Set this argument to either:

`OS_OPT_PEND_BLOCKING`, or

`OS_OPT_PEND_NON_BLOCKING`

Note that the timeout argument should be set to 0 when specifying `OS_OPT_PEND_NON_BLOCKING`, since the timeout value is irrelevant using this option.

`p_ts` is a pointer to a timestamp indicating when the task's semaphore was posted, or the pend was aborted. If passing a `NULL` pointer (i.e., `(CPU_TS *)0`) the timestamp will not be returned. In other words, passing a `NULL` pointer is valid and indicates that the timestamp is not necessary.

A timestamp is useful when the task is to know when the semaphore was posted, or how long it took for the task to resume after the semaphore was posted. In the latter case, call `OS_TS_GET()` and compute the difference between the current value of the timestamp and `*p_ts`. In other words:

```
delta = OS_TS_GET() - *p_ts;
```

`p_err` is a pointer to a variable used to hold an error code.

|                                      |  |
|--------------------------------------|--|
| <code>OS_ERR_NONE</code>             | if a signal is received.   |
| <code>OS_ERR_PEND_ABORT</code>       | if the pend was aborted because another task called <code>OSTaskSemPendAbort()</code> .  |
| <code>OS_ERR_PEND_ISR</code>         | if calling this function from an ISR.  |
| <code>OS_ERR_PEND_WOULD_BLOCK</code> | if calling this function with the <code>opt</code> argument set to <code>OS_OPT_PEND_NON_BLOCKING</code> , and no signal was received. |
| <code>OS_ERR_SCHED_LOCKED</code>     | if calling this function when the scheduler is locked and the user wanted the task to block.   |
| <code>OS_ERR_TIMEOUT</code>          | if a signal is not received within the specified timeout.  |

### **Returned Value**

The current value of the signal counter after it has been decremented. In other words, the number of signals still remaining in the signal counter.

### **Notes/Warnings**

Do not call `OSTaskSemPend()` from an ISR.

## Example

```
void CommTask(void *p_arg)
{
    OS_ERR    err;
    OS_SEM_CTR ctr;
    CPU_TS    ts;

    (void)&p_arg;
    while (DEF_ON) {
        :
        ctr = OSTaskSemPend(100,
                           OS_OPT_PEND_BLOCKING,
                           &ts,
                           &err);
        /* Check "err" */
        :
    }
}
```

# OSTaskSemPendAbort()

```
CPU_BOOLEAN OSTaskSemPendAbort (OS_TCB *p_tcb,  
                                OS_OPT  opt,  
                                OS_ERR  *p_err)
```

| File      | Called from | Code enabled by               |
|-----------|-------------|-------------------------------|
| OS_TASK.C | Task        | OS_CFG_TASK_SEM_PEND_ABORT_EN |

OSTaskSemPendAbort() aborts and readies a task currently waiting on its built-in semaphore. This function should be used to fault-abort the wait on the task's semaphore, rather than to normally signal the task via OSTaskSemPost().

## Arguments

**p\_tcb** is a pointer to the task for which the pend must be aborted. Note that it does not make sense to pass a NULL pointer or the address of the calling task's TCB since, by definition, the calling task cannot be pending.

**opt** provides options for this function.

**OS\_OPT\_POST\_NONE** no option specified, call the scheduler by default.

**OS\_OPT\_POST\_NO\_SCHED** specifies that the scheduler should not be called even if the pend of a higher-priority task has been aborted. Scheduling will need to occur from another function.

Use this option if the task calling OSTaskSemPendAbort() will be doing additional pend aborts, rescheduling will not take place until finished, and multiple pend aborts are to take effect simultaneously.

`p_err` is a pointer to a variable that holds an error code:

|                                     |  |
|-------------------------------------|--|
| <code>OS_ERR_NONE</code>            | the pend was aborted for the specified task.   |
| <code>OS_ERR_PEND_ABORT_ISR</code>  | if called from an ISR  |
| <code>OS_ERR_PEND_ABORT_NONE</code> | if the task was not waiting for a signal.  |
| <code>OS_ERR_PEND_ABORT_SELF</code> | if <code>p_tcb</code> is a <code>NULL</code> pointer or the TCB of the calling task is specified. The user is attempting to pend abort the calling task, which makes no sense since, by definition, the calling task is not pending. |

### Returned Value

`OSTaskSemPendAbort()` returns `DEF_TRUE` if the task was made ready to run by this function. `DEF_FALSE` indicates that the task was not pending, or an error occurred.

### Notes/Warnings

None

### Example

```
OS_TCB  CommRxTaskTCB;

void CommTask (void *p_arg)
{
    OS_ERR    err;
    CPU_BOOLEAN  aborted;

    (void)&p_arg;
    while (DEF_ON) {
        :
        :
        aborted = OSTaskSemPendAbort (&CommRxTaskTCB,
                                      OS_OPT_POST_NONE,
                                      &err);

        /* Check "err" */
        :
        :
    }
}
```

# OSTaskSemPost ( )

```
OS_SEM_CTR  OSTaskSemPost (OS_TCB    *p_tcb,  
                           OS_OPT     opt,  
                           OS_ERR     *p_err)
```

| File      | Called from | Code enabled by |
|-----------|-------------|-----------------|
| OS_TASK.C | Task or ISR | Always enabled  |

OSTaskSemPost( ) sends a signal to a task through its local semaphore.

If the task receiving the signal is actually waiting for a signal to be received, it will be made ready to run and, if the receiving task has a higher priority than the task sending the signal, the higher-priority task resumes, and the task sending the signal is suspended; that is, a context switch occurs. Note that scheduling only occurs if opt is set to OS\_OPT\_POST\_NONE, because the OS\_OPT\_POST\_NO\_SCHED option does not cause the scheduler to be called.

## Arguments

**p\_tcb** is a pointer to the TCB of the task being signaled. A NULL pointer indicates that the user is sending a signal to itself.

**opt** provides options to the call.

**OS\_OPT\_POST\_NONE** No option, by default the scheduler will be called.

**OS\_OPT\_POST\_NO\_SCHED** Do not call the scheduler after the post, therefore the caller is resumed.

Use this option if the task (or ISR) calling OSTaskSemPost( ) will be doing additional posts, reschedule waits until all is done, and multiple posts are to take effect simultaneously.

**p\_err** is a pointer to a variable that will contain an error code returned by this function.

**OS\_ERR\_NONE** if the call was successful and the signal was sent.

OS\_ERR\_SEM\_OVF

the post would have caused the semaphore counter to overflow.

### Returned Value

The current value of the task's signal counter, or 0 if called from an ISR and OS\_CFG\_ISR\_POST\_DEFERRED\_EN is set to 1.

### Notes/Warnings

None

### Example

```
OS_TCB      CommRxTaskTCB;

void CommTaskRx (void *p_arg)
{
    OS_ERR      err;
    OS_SEM_CTR  ctr;

    (void)&p_arg;
    while (DEF_ON) {
        :
        ctr = OSTaskSemPost(&CommRxTaskTCB,
                            OS_OPT_POST_NONE,
                            &err);
        /* Check "err" */
        :
    }
}
```



# OSTaskSemSet ( )

```
OS_SEM_CTR OSTaskSemSet (OS_TCB      *p_tcb,  
                          OS_SEM_CTR  cnt;  
                          OS_ERR      *p_err)
```

| File      | Called from | Code enabled by |
|-----------|-------------|-----------------|
| OS_TASK.C | Task or ISR | Always Enabled  |

OSTaskSemSet ( ) allows the user to set the value of the task's signal counter. Set the signal counter of the calling task by passing a `NULL` pointer for `p_tcb`.

## Arguments

`p_tcb` is a pointer to the task's `OS_TCB` to clear the signal counter. A `NULL` pointer indicates that the user wants to clear the caller's signal counter.

`cnt` the desired value for the task semaphore counter.

`p_err` is a pointer to a variable that will contain an error code returned by this function.

`OS_ERR_NONE` if the call was successful and the signal counter was cleared.

`OS_ERR_SET_ISR` if calling this function from an ISR

## Returned Value

The value of the signal counter prior to setting it.

## Notes/Warnings

None

## Example

```
OS_TCB TaskY;

void TaskX (void *p_arg)
{
    OS_ERR err;

    while (DEF_ON) {
        :
        :
        OSTaskSemSet(&TaskY,
                    0,
                    &err);
        /* Check "err" */
        :
        :
    }
}
```

# OSTaskStatHook ()

void OSTaskStatHook (void);

| File       | Called from        | Code enabled by     |
|------------|--------------------|---------------------|
| OS_CPU_C.C | OS_TaskStat() ONLY | OS_CFG_TASK_STAT_EN |

This function is called by OS\_TaskStat().

OSTaskStatHook() is part of the CPU port code and *must not* be called by the application code. OSTaskStatHook() is actually used by the μC/OS-III port developer.

## Arguments

None

## Returned Value

None

## Notes/Warnings

*Do not* call this function from the application.

## Example

The code below calls an application-specific hook that the application programmer can define. The user can simply set the value of OS\_AppStatTaskHookPtr to point to the desired hook function as shown in the example. The statistic task calls OSStatTaskHook() which in turns calls App\_OS\_StatTaskHook() through OS\_AppStatTaskHookPtr.

```
void App_OS_StatTaskHook (void)                                /* OS_APP_HOOKS.C      */
{
    /* Your code goes here! */
}

void App_OS_SetAllHooks (void)                                /* OS_APP_HOOKS.C      */
{
    CPU_SR_ALLOC();

    CPU_CRITICAL_ENTER();
    :
    OS_AppStatTaskHookPtr = App_OS_StatTaskHook;
    :
    CPU_CRITICAL_EXIT();
}

void OSStatTaskHook (void)                                    /* OS_CPU_C.C          */
{
    #if OS_CFG_APP_HOOKS_EN > 0u
        if (OS_AppStatTaskHookPtr != (OS_APP_HOOK_VOID)0) { /* Call application hook */
            (*OS_AppStatTaskHookPtr)();
        }
    #endif
}
```

# OSTaskStkChk ( )

```
void OSTaskStkChk (OS_TCB      *p_tcb,  
                  CPU_STK_SIZE *p_free,  
                  CPU_STK_SIZE *p_used,  
                  OS_ERR       *p_err)
```

| File      | Called from | Code enabled by         |
|-----------|-------------|-------------------------|
| OS_TASK.C | Task        | OS_CFG_TASK_STAT_CHK_EN |

**OSTaskStkChk()** determines a task's stack statistics. Specifically, it computes the amount of free stack space, as well as the amount of stack space used by the specified task. This function requires that the task be created with the **OS\_TASK\_OPT\_STK\_CHK** and **OS\_TASK\_OPT\_STK\_CLR** options.

Stack sizing is accomplished by walking from the bottom of the stack and counting the number of 0 entries on the stack until a non-zero value is found. It is possible to not set the **OS\_TASK\_OPT\_STK\_CLR** when creating the task if the startup code clears all RAM, and tasks are not deleted (this reduces the execution time of **OSTaskCreate()**).

μC/OS-III's statistic task calls **OSTaskStkChk()** for each task created and stores the results in each task's **OS\_TCB** so your application doesn't need to call this function if the statistic task is enabled.

## Arguments

- p\_tcb** is a pointer to the TCB of the task where the stack is being checked. A **NULL** pointer indicates that the user is checking the calling task's stack.
- p\_free** is a pointer to a variable of type **CPU\_STK\_SIZE** and will contain the number of free "bytes" on the stack of the task being inquired about.
- p\_used** is a pointer to a variable of type **CPU\_STK\_SIZE** and will contain the number of used "bytes" on the stack of the task being inquired about.

**p\_err** is a pointer to a variable that will contain an error code returned by this function.

|                                      |  |
|--------------------------------------|--|
| <code>OS_ERR_NONE</code>             | if the call was successful.  |
| <code>OS_ERR_PTR_INVALID</code>      | if either <code>p_free</code> or <code>p_used</code> are <code>NULL</code> pointers.       |
| <code>OS_ERR_TASK_NOT_EXIST</code>   | if the stack pointer of the task is a <code>NULL</code> pointer.                           |
| <code>OS_ERR_TASK_OPT</code>         | if <code>OS_OPT_TASK_STK_CHK</code> is not specified when creating the task being checked. |
| <code>OS_ERR_TASK_STK_CHK_ISR</code> | if calling this function from an ISR.  |

### Returned Value

None

### Notes/Warnings

1. Execution time of this task depends on the size of the task's stack.
2. The application can determine the total task stack space (in number of bytes) by adding the value of `*p_free` and `*p_used`.
3. The `#define CPU_CFG_STK_GROWTH` must be declared (typically from `OS_CPU.H`). When this `#define` is set to `CPU_STK_GROWTH_LO_TO_HI`, the stack grows from low memory to high memory. When this `#define` is set to `CPU_STK_GROWTH_HI_TO_LO`, the stack grows from high memory to low memory.

## Example

```
OS_TCB MyTaskTCB;

void Task (void *p_arg)
{
    OS_ERR      err;
    CPU_STK_SIZE n_free;
    CPU_STK_SIZE n_used;

    (void)&p_arg;
    while (DEF_ON) {
        :
        :
        OSTaskStkChk(&MyTaskTCB,
                    &n_free,
                    &n_used,
                    &err);
        /* Check "err" */
        :
        :
    }
}
```

## OSTaskStkInit()

```
void OSTaskStkInit (OS_TASK_PTR   p_task,
                  void           *p_arg,
                  CPU_STK        *p_stk_base,
                  CPU_STK        *p_stk_limit,
                  CPU_STK_SIZE   stk_size,
                  OS_OPT         opt);
```

| File       | Called from         | Code enabled by |
|------------|---------------------|-----------------|
| OS_CPU_C.C | OSTaskCreate() ONLY | N/A             |

This function is called by `OSTaskCreate()` to setup the stack frame of the task being created. Typically, the stack frame will look as if an interrupt just occurred, and all CPU registers were pushed onto the task's stack. The stacking order of CPU registers is very CPU specific.

`OSTaskStkInit()` is part of the CPU port code and this function *must not* be called by the application code. `OSTaskStkInit()` is actually defined by the  $\mu$ C/OS-III port developer.

### Arguments

`p_task` is the address of the task being created (see `MyTask` below). Tasks must be declared as follows:

```
void MyTask (void *p_arg)
{
    /* Do something with "p_arg" (optional) */
    while (DEF_ON) {
        /* Wait for an event to occur */
        /* Do some work */
    }
}
```



Or,

```
void MyTask (void *p_arg)
{
    OS_ERR err;

    /* Do something with "p_arg" (optional) */
    /* Do some work */
    OSTaskDel((OS_TCB *)0,
              &err);
}
```

**p\_arg** is the argument that the task will receive when the task first start (see code above).

**p\_stk\_base** is the base address of the task's stack. This is typically the lowest address of the area of storage reserved for the task stack. In other words, if declaring the task's stack as follows:

```
CPU_STK MyTaskStk[100];
```

**OSTaskCreate()** would pass **&OSMyTaskStk[0]** to **p\_stk\_base**.

**p\_stk\_limit** is the address of the task's stack limit watermark. This pointer is the same pointer passed to **OSTaskCreate()**.

**stk\_size** is the size of the task's stack in number of **CPU\_STK** elements. In the example above, the stack size is 100.

**opt** is the options pass to **OSTaskCreate()** for the task being created.

### **Returned Value**

The new top of stack after the task's stack is initialized. **OSTaskStkInit()** will place values on the task's stack and will return the new pointer of the stack pointer for the task. The value returned is very processor specific. For some processors, the returned value will point to the last value placed on the stack while, with other processors, the returned value will point at the next free stack entry.

---

## Notes/Warnings

*Do not* call this function from the application.

## Example

The pseudo code below shows the typical steps performed by this function. Consult an existing  $\mu$ C/OS-III port for examples. Here it is assumed that the stack grows from high memory to low memory.

```
CPU_STK *OSTaskStkInit (OS_TASK_PTR  p_task,
                       void          *p_arg,
                       CPU_STK       *p_stk_base,
                       CPU_STK       *p_stk_limit,
                       CPU_STK_SIZE  stk_size,
                       OS_OPT        opt)
{
    CPU_STK  *p_stk;

    p_stk    = &p_stk_base[stk_size - 1u];           (1)
    *p_stk-- = Initialize the stack as if an interrupt just occurred; (2)
    return (p_stk);                                  (3)
}
```

- (1) ‘p\_stk’ is set to the top-of-stack. It is assumed that the stack grows from high memory locations to lower ones. If the stack of the CPU grew from low memory locations to higher ones, the user would simply set ‘p\_stk’ to point at the base. However, this also means that it would be necessary to initialize the stack frame in the opposite direction.
- (2) Store the CPU registers onto the stack using the same stacking order as used when an interrupt service routine (ISR) saves the registers at the beginning of the ISR. The value of the register contents on the stack is typically not important. However, there are some values that are critical. Specifically, place the address of the task in the proper location on the stack frame and it may be important to load the value of the CPU register and possibly pass the value of ‘p\_arg’ in one of the CPU registers. Finally, if the task is to return by mistake, it is a good idea to place the address of ‘OS\_TaskReturn( )’ in the proper location on the stack frame. This ensures that a faulty returning task is intercepted by  $\mu$ C/OS-III.

- (3) Finally, return the value of the stack pointer at the new top-of-stack frame. Some processors point to the last stored location, while others point to the next empty location. Consult the processor documentation so that the return value points at the proper location.

Below is a complete example showing `OSTaskCreate()` which calls `OSTaskStkInit()` with the proper arguments.

```
CPU_STK  MyTaskStk[100];
OS_TCB   MyTaskTCB;

void MyTask (void *p_arg)
{
    /* Do something with "parg" (optional) */
}

void main (void)
{
    OS_ERR  err;
    :
    :
    OSInit(&err);
    /* Check "err" */
    :
    OSTaskCreate ((OS_TCB      *)&MyTaskTCB,
                  (CPU_CHAR   *)"My Task",
                  (OS_TASK_PTR )MyTask,      /* "p_task"   of OSTaskStkInit() */
                  (void       *)0,          /* "p_arg"   of OSTaskStkInit() */
                  (OS_PRIO    )prio,
                  (CPU_STK    *)&MyTaskStk[0], /* "p_stk_base" of OSTaskStkInit() */
                  (CPU_STK_SIZE)10,         /* "p_stk_limit" of OSTaskStkInit() */
                  (CPU_STK_SIZE)100,       /* "stk_size"  of OSTaskStkInit() */
                  (OS_MSG_QTY )0,
                  (OS_TICK    )0,
                  (void       *)0,
                  (OS_OPT     )(OS_OPT_TASK_STK_CLR + OS_OPT_TASK_STK_CHK), /* "opt" */
                  (OS_ERR    *)&err);

    /* Check "err" */
    :
    :
    OSStart(&err);
    /* Check "err" */
}
```

# OSTaskSuspend()

```
void OSTaskSuspend (OS_TCB *p_tcb,
                   OS_ERR *p_err)
```

| File      | Called from | Code enabled by        |
|-----------|-------------|------------------------|
| OS_TASK.C | Task        | OS_CFG_TASK_SUSPEND_EN |

**OSTaskSuspend()** suspends (or blocks) execution of a task unconditionally. The calling task may be suspended by specifying a **NULL** pointer for *p\_tcb*, or simply by passing the address of its **OS\_TCB**. In this case, another task needs to resume the suspended task. If the current task is suspended, rescheduling occurs, and  $\mu$ C/OS-III runs the next highest priority task ready to run. The only way to resume a suspended task is to call **OSTaskResume()**.

Task suspension is additive, which means that if the task being suspended is delayed until *n* ticks expire, the task is resumed only when both the time expires and the suspension is removed. Also, if the suspended task is waiting for a semaphore and the semaphore is signaled, the task is removed from the semaphore wait list (if it is the highest-priority task waiting for the semaphore), but execution is not resumed until the suspension is removed.

The user can “nest” suspension of a task by calling **OSTaskSuspend()** and therefore it is important to call **OSTaskResume()** an equivalent number of times to resume the task. If suspending a task five times, it is necessary to unsuspend the same task five times to remove the suspension of the task.

## Arguments

**p\_tcb** is a pointer to the TCB of the task the user is suspending. A **NULL** pointer indicates suspension of the calling task.

**p\_err** is a pointer to a variable that will contain an error code returned by this function.

|                                |  |
|--------------------------------|--|
| <b>OS_ERR_NONE</b>             | if the call was successful and the desired task was suspended. |
| <b>OS_ERR_TASK_SUSPEND_ISR</b> | if the function is called from an ISR.                         |

**OS\_ERR\_TASK\_SUSPEND\_IDLE** if attempting to suspend the idle task. This is not allowed since the idle task must always exist.

**OS\_ERR\_TASK\_SUSPEND\_INT\_HANDLER** if attempting to suspend the ISR handler task. This is not allowed since the ISR handler task is a μC/OS-III internal task.

### **Returned Value**

None

### **Notes/Warnings**

1. `OSTaskSuspend()` and `OSTaskResume()` must be used in pairs.
2. A suspended task can only be resumed by `OSTaskResume()`.

### **Example**

```
void TaskX (void *p_arg)
{
    OS_ERR  err;

    (void)&p_arg;
    while (DEF_ON) {
        :
        :
        OSTaskSuspend((OS_TCB *)0,
                      &err);      /* Suspend current task          */
        /* Check "err" */
        :
    }
}
```

# OSTaskSwHook ()

```
void OSTaskSwHook (void)
```

| File       | Called from               | Code enabled by |
|------------|---------------------------|-----------------|
| OS_CPU_C.C | OSCtxSw() or OSIntCtxSw() | N/A             |

OSTaskSwHook() is always called by either OScCtxSw() or OSIntCtxSw() (see OS\_CPU\_A.ASM), just after saving the CPU registers onto the task being switched out. This hook function allows the port developer to perform additional operations (if needed) when  $\mu$ C/OS-III performs a context switch.

Before calling OSTaskSwHook(), OSTCBCurPtr is set to point at the OS\_TCB of the task being switched out, and OSTCBHighRdyPtr points at the OS\_TCB of the new task being switched in.

The code shown in the example below should be included in all implementations of OSTaskSwHook(), and is used for performance measurements. This code is written in C for portability.

## Arguments

None

## Returned Values

None

## Notes/Warnings

None

## Example

The code below calls an application specific hook that the application programmer can define. The user can simply set the value of OS\_AppTaskSwHookPtr to point to the desired hook function. When  $\mu$ C/OS-III performs a context switch, it calls OSTaskSwitchHook() which in turn calls App\_OS\_TaskSwHook() through OS\_AppTaskSwHookPtr.

```
void App_OS_TaskSwHook (void)                /* OS_APP_HOOKS.C      */
{
    /* Your code goes here! */
}

void App_OS_SetAllHooks (void)               /* OS_APP_HOOKS.C      */
{
    CPU_SR_ALLOC();

    CPU_CRITICAL_ENTER();
    :
    OS_AppTaskSwHookPtr = App_OS_TaskSwHook;
    :
    CPU_CRITICAL_EXIT();
}
```

```
void OSTaskSwHook (void) /* OS_CPU_C.C */
{
    #if OS_CFG_TASK_PROFILE_EN > 0u
        CPU_TS    ts;
    #endif
    #ifndef CPU_CFG_TIME_MEAS_INT_DIS_EN
        CPU_TS    int_dis_time;
    #endif

    #if OS_CFG_APP_HOOKS_EN > 0u
        if (OS_AppTaskSwHookPtr != (OS_APP_HOOK_VOID)0) {
            (*OS_AppTaskSwHookPtr)();
        }
    #endif
    #if OS_CFG_TASK_PROFILE_EN > 0u
        ts = OS_TS_GET();
        if (OSTCBCurPtr != OSTCBHighRdyPtr) {
            OSTCBCurPtr->CyclesDelta = ts - OSTCBCurPtr->CyclesStart;
            OSTCBCurPtr->CyclesTotal = OSTCBCurPtr->CyclesTotal + OSTCBCurPtr->CyclesDelta;
        }
        OSTCBHighRdyPtr->CyclesStart = ts;
    #ifndef CPU_CFG_INT_DIS_MEAS_EN
        int_dis_time = CPU_IntDisMeasMaxCurReset();
        if (int_dis_time > OSTCBCurPtr->IntDisTimeMax) {
            OSTCBCurPtr->IntDisTimeMax = int_dis_time;
        }
    #endif
    #if OS_CFG_SCHED_LOCK_TIME_MEAS_EN > 0u
        if (OSSchedLockTimeMaxCur > OSTCBCurPtr->SchedLockTimeMax) {
            OSTCBCurPtr->SchedLockTimeMax = OSSchedLockTimeMaxCur;
            OSSchedLockTimeMaxCur      = (CPU_TS)0;
        }
    #endif
    #endif
}
```



---

# OSTaskTimeQuantaSet()

```
void OSTaskTimeQuantaSet (OS_TCB *p_tcb,  
                          OS_TICK time_quanta,  
                          OS_ERR *p_err)
```

| File      | Called from | Code enabled by             |
|-----------|-------------|-----------------------------|
| OS_TASK.C | Task only   | OS_CFG_SCHED_ROUND_ROBIN_EN |

OSTaskTimeQuantaSet() is used to change the amount of time a task is given when time slicing multiple tasks running at the same priority.

## Arguments

**p\_tcb** is a pointer to the TCB of the task for which the time quanta is being set. A **NULL** pointer indicates that the user is changing the time quanta for the calling task.

**time\_quanta** specifies the amount of time (in ticks) that the task will run when μC/OS-III is time slicing between tasks at the same priority. Specifying 0 indicates that the default time as specified will be used when calling the function **OSSchedRoundRobinCfg()**, or **OS\_CFG\_TICK\_RATE\_HZ / 10** if you never called **OSSchedRoundRobinCfg()**.

Do not specify a “large” value for this argument as this means that the task will execute for that amount of time when multiple tasks are ready to run at the same priority. The concept of time slicing is to allow other equal-priority tasks a chance to run. Typical time quanta periods should be approximately 10 mS. A too small value results in more overhead because of the additional context switches.

**p\_err** is a pointer to a variable that will contain an error code returned by this function.

**OS\_ERR\_NONE** if the call was successful and the time quanta for the task was changed.

**OS\_ERR\_SET\_ISR** if calling this function from an ISR.

### Returned Value

None

### Notes/Warnings

Do not specify a large value for time\_quanta.

### Example

```
void TaskX (void *p_arg)
{
    OS_ERR err;

    while (DEF_ON) {
        :
        :
        OSTaskTimeQuantaSet((OS_TCB *)0,
                            OS_CFG_TICK_RATE_HZ / 4;
                            &err);
        /* Check "err" */
        :
    }
}
```

# OSTickISR()

void OSTickISR (void)

| File         | Called from    | Code enabled by |
|--------------|----------------|-----------------|
| OS_CPU_A.ASM | Tick interrupt | N/A             |

OSTickISR() is invoked by the tick interrupt, and the function is generally written in assembly language. However, this depends on how interrupts are handled by the processor. (see Chapter 9, “Interrupt Management” on page 157).

## Arguments

None

## Returned Values

None

## Notes/Warnings

None

## Example

The code below indicates how to write OSTickISR() if all interrupts vector to a common location, and the interrupt handler simply calls OSTickISR(). As indicated, this code can be written completely in C and can be placed either in OS\_CPU\_C.C of the μC/OS-III port, or in the board support package (BSP.C) and be reused by applications using the same BSP.

```
void OSTickISR (void)
{
    Clear the tick interrupt;
    OSTimeTick();
}
```

The pseudo code below shows how to write OSTickISR() if each interrupt directly vectors to its own interrupt handler. The code, in this case, would be written in assembly language and placed either in OS\_CPU\_A.ASM of the μC/OS-III port, or in the board support package (BSP.C).

```
void OSTickISR (void)
{
    Save all the CPU registers onto the current task's stack;
    if (OSIntNestingCtr == 0) {
        OSTCBCurPtr->StkPtr = SP;
    }
    OSIntNestingCtr++;
    Clear the tick interrupt;
    OSTimeTick();
    OSIntExit();
    Restore the CPU registers from the stack;
    Return from interrupt;
}
```

# OSTimeDly()

```
void OSTimeDly (OS_TICK  dly,  
               OS_OPT   opt,  
               OS_ERR  *p_err)
```

| File      | Called from | Code enabled by |
|-----------|-------------|-----------------|
| OS_TIME.C | Task only   | N/A             |

OSTimeDly() allows a task to delay itself for an integral number of clock ticks. The delay can either be relative (delay from current time), periodic (delay occurs at fixed intervals) or absolute (delay until we reach some time).

In relative mode, rescheduling always occurs when the number of clock ticks is greater than zero. A delay of 0 means that the task is not delayed, and OSTimeDly() returns immediately to the caller.

In periodic mode, you must specify a non-zero period otherwise the function returns immediately with an appropriate error code. The period is specified in “ticks”.

In absolute mode, rescheduling always occurs since all delay values are valid.

The actual delay time depends on the tick rate (see OS\_CFG\_TICK\_RATE\_HZ).

## Arguments

**dly** is the desired delay expressed in number of clock ticks. Depending on the value of the **opt** field, delays can be relative or absolute.

A relative delay means that the delay is started from the “current time + dly”.

A periodic delay means the period (in number of ticks).

An absolute delay means that the task will wake up when OSTaskTickCtr reaches the value specified by **dly**.

**opt** is used to indicate whether the delay is absolute or relative:

|                                   |  |
|-----------------------------------|--|
| <code>OS_OPT_TIME_DLY</code>      | Specifies a relative delay.  |
| <code>OS_OPT_TIME_PERIODIC</code> | Specifies periodic mode.   |
| <code>OS_OPT_TIME_MATCH</code>    | Specifies that the task will wake up when <code>OSTaskTickCtr</code> reaches the value specified by <code>dly</code> |

**p\_err** is a pointer to a variable that will contain an error code returned by this function.

|                                   |  |
|-----------------------------------|--|
| <code>OS_ERR_NONE</code>          | if the call was successful, and the task has returned from the desired delay.  |
| <code>OS_ERR_OPT_INVALID</code>   | if a valid option is not specified.  |
| <code>OS_ERR_TIME_DLY_ISR</code>  | if calling this function from an ISR.  |
| <code>OS_ERR_TIME_ZERO_DLY</code> | if specifying a delay of 0 when the option was set to <code>OS_OPT_TIME_DLY</code> . Note that a value of 0 is valid when setting the option to <code>OS_OPT_TIME_MATCH</code> . |

**Returned Value**

None

**Notes/Warnings**

None

## **Example**

```
void TaskX (void *p_arg)
{
    OS_ERR  err;

    while (DEF_ON) {
        :
        :
        OSTimeDly(10,
                 OS_OPT_TIME_PERIODIC,
                 &err);
        /* Check "err" */
        :
        :
    }
}
```

## OSTimeDlyHMSM()

```
void OSTimeDlyHMSM (CPU_INT16U hours,
                    CPU_INT16U minutes,
                    CPU_INT16U seconds,
                    CPU_INT32U milli,
                    OS_OPT opt,
                    OS_ERR *p_err)
```

| File      | Called from | Code enabled by         |
|-----------|-------------|-------------------------|
| OS_TIME.C | Task only   | OS_CFG_TIME_DLY_HMSM_EN |

`OSTimeDlyHMSM()` allows a task to delay itself for a user-specified period that is specified in hours, minutes, seconds, and milliseconds. This format is more convenient and natural than simply specifying ticks as is true in the case of `OSTimeDly()`. Rescheduling always occurs when at least one of the parameters is non-zero. The delay is relative from the time this function is called.

$\mu$ C/OS-III allows the user to specify nearly any value when indicating that this function is not to be strict about the values being passed (`opt == OS_OPT_TIME_HMSM_NON_STRICT`). This is a useful feature, for example, to delay a task for thousands of milliseconds.

### Arguments

**hours** is the number of hours the task is delayed. Depending on the `opt` value, the valid range is 0..99 (`OS_OPT_TIME_HMSM_STRICT`), or 0..999 (`OS_OPT_TIME_HMSM_NON_STRICT`). Please note that it *not* recommended to delay a task for many hours because feedback from the task will not be available for such a long period of time.

**minutes** is the number of minutes the task is delayed. The valid range of values is 0 to 59 (`OS_OPT_TIME_HMSM_STRICT`), or 0..9,999 (`OS_OPT_TIME_HMSM_NON_STRICT`). Please note that it *not* recommended to delay a task for tens to hundreds of minutes because feedback from the task will not be available for such a long period of time.

**seconds** is the number of seconds the task is delayed. The valid range of values is 0 to 59 (`OS_OPT_TIME_HMSM_STRICT`), or 0..65,535 (`OS_OPT_TIME_HMSM_NON_STRICT`).



**milli** is the number of milliseconds the task is delayed. The valid range of values is 0 to 999 (`OS_OPT_TIME_HMSM_STRICT`), or 0..4,294,967,295 (`OS_OPT_TIME_HMSM_NON_STRICT`). Note that the resolution of this argument is in multiples of the tick rate. For instance, if the tick rate is set to 100Hz, a delay of 4 ms results in no delay. Also, the delay is rounded to the nearest tick. Thus, a delay of 15 ms actually results in a delay of 20 ms.

**opt** is the desired mode and can be either:

`OS_OPT_TIME_HMSM_STRICT` (see above)

`OS_OPT_TIME_HMSM_NON_STRICT`(see above)

**p\_err** is a pointer to a variable that contains an error code returned by this function.

`OS_ERR_NONE` if the call was successful and the task has returned from the desired delay.

`OS_ERR_TIME_DLY_ISR` if calling this function from an ISR.

`OS_ERR_TIME_INVALID_HOURS` if not specifying a valid value for hours.

`OS_ERR_TIME_INVALID_MINUTES`if not specifying a valid value for minutes.

`OS_ERR_TIME_INVALID_SECONDS`if not specifying a valid value for seconds.

`OS_ERR_TIME_INVALID_MILLISECONDS`if not specifying a valid value for milliseconds.

`OS_ERR_TIME_ZERO_DLY` if specifying a delay of 0 because all the time arguments are 0.

### **Returned Value**

None

### **Notes/Warnings**

1. Note that `OSTimeDlyHMSM(0,0,0,0,OS_OPT_TIME_HMSM_???,&err)` (i.e., hours, minutes, seconds, milliseconds are 0) results in no delay, and the function returns to the caller.

2. The total delay (in ticks) must not exceed the maximum acceptable value that an `OS_TICK` variable can hold. Typically `OS_TICK` is a 32-bit value.

## Example

```
void TaskX (void *p_arg)
{
    OS_ERR  err;

    while (DEF_ON) {
        :
        :
        OSTimeDlyHMSM(0,
                      0,
                      1,
                      0,
                      OS_OPT_TIME_HMSM_STRICT,
                      &err);          /* Delay task for 1 second */
        /* Check "err" */
        :
        :
    }
}
```

# OSTimeDlyResume ()

```
void OSTimeDlyResume (OS_TCB *p_tcb,  
                      OS_ERR *p_err)
```

| File      | Called from | Code enabled by           |
|-----------|-------------|---------------------------|
| OS_TIME.C | Task only   | OS_CFG_TIME_DLY_RESUME_EN |

OSTimeDlyResume() resumes a task that has been delayed through a call to either OSTimeDly(), or OSTimeDlyHMSM().

## Arguments

**p\_tcb** is a pointer to the TCB of the task that is resuming. A **NULL** pointer is not valid since it would indicate that the user is attempting to resume the current task and that is not possible as the caller cannot possibly be delayed.

**p\_err** is a pointer to a variable that contains an error code returned by this function.

- OS\_ERR\_NONE if the call was successful and the task was resumed.
- OS\_ERR\_STATE\_INVALID if the task is in an invalid state.
- OS\_ERR\_TIME\_DLY\_RESUME\_ISR if calling this function from an ISR.
- OS\_ERR\_TIME\_NOT\_DLY if the task was not delayed.
- OS\_ERR\_TASK\_SUSPENDED if the task to resume is suspended and will remain suspended.

## Returned Value

None

## Notes/Warnings

Do not call this function to resume a task that is waiting for an event with timeout.

## Example

```
OS_TCB AnotherTaskTCB;

void TaskX (void *p_arg)
{
    OS_ERR err;

    while (DEF_ON) {
        :
        OSTimeDlyResume(&AnotherTaskTCB,
                       &err);
        /* Check "err" */
        :
    }
}
```

# OSTimeGet ()

OS\_TICK OSTimeGet (OS\_ERR \*p\_err)

| File      | Called from | Code enabled by |
|-----------|-------------|-----------------|
| OS_TIME.C | Task + ISR  | N/A             |

OSTimeGet() obtains the current value of the system clock. Specifically, it returns a snapshot of the variable OSTaskTickCtr. The system clock is a counter of type OS\_TICK that counts the number of clock ticks since power was applied, or since OSTaskTickCtr was last set by OSTimeSet().

## Arguments

**p\_err** is a pointer to a variable that contains an error code returned by this function.

OS\_ERR\_NONE if the call was successful.

## Returned Value

The current value of OSTaskTickCtr (in number of ticks).

## Notes/Warnings

None

## Example

```
void TaskX (void *p_arg)
{
    OS_TICK  clk;
    OS_ERR  err;

    while (DEF_ON) {
        :
        :
        clk = OSTimeGet(&err); /* Get current value of system clock */
        /* Check "err" */
        :
        :
    }
}
```

---

# OSTimeSet()

```
void OSTimeSet (OS_TICK ticks,  
               OS_ERR *p_err)
```

| File      | Called from | Code enabled by |
|-----------|-------------|-----------------|
| OS_TIME.C | Task + ISR  | N/A             |

`OSTimeSet()` sets the system clock. The system clock is a counter, which has a data type of `OS_TICK`, and it counts the number of clock ticks since power was applied. or since the system clock was last set.

## Arguments

`ticks` is the desired value for the system clock, in ticks.

`p_err` is a pointer to a variable that will contain an error code returned by this function.

`OS_ERR_NONE` if the call was successful.

## Returned Value

None

## Notes/Warnings

You should be careful when using this function because other tasks may depend on the current value of the tick counter (`OSTickCtr`). Specifically, a task may delay itself (see `OSTimeDly()`) and specify to wake up when `OSTickCtr` reaches a specific value.

## **Example**

```
void TaskX (void *p_arg)
{
    OS_ERR  err;

    while (DEF_ON) {
        :
        :
        OSTimeSet(0,          /* Reset the system clock */
                 &err);
        /* Check "err" */
        :
        :
    }
}
```

# OSTimeTick ()

void OSTimeTick (void)

| File      | Called from | Code enabled by |
|-----------|-------------|-----------------|
| OS_TIME.C | ISR         | N/A             |

OSTimeTick() “announces” that a tick has just occurred, and that time delays and timeouts need to be updated. This function must be called from the tick ISR.

## Arguments

None

## Returned Value

None

## Notes/Warnings

None

## Example

```
void MyTickISR (void)
{
    /* Clear interrupt source */
    OSTimeTick();
    :
    :
}
```



# OSTimeTickHook ()

```
void OSTimeTickHook (void);
```

| File       | Called from       | Code enabled by |
|------------|-------------------|-----------------|
| OS_CPU_C.C | OSTimeTick() ONLY | N/A             |

This function is called by `OSTimeTick()`, which is assumed to be called from an ISR. `OSTimeTickHook()` is called at the very beginning of `OSTimeTick()` to give priority to user or port-specific code when the tick interrupt occurs.

If the `#define OS_APP_HOOKS_EN` is set to 1 in `OS_CFG.H`, `OSTimeTickHook()` will call `AppTimeTickHook()`.

`OSTimeTickHook()` is part of the CPU port code and the function *must not* be called by the application code. `OSTimeTickHook()` is actually used by the μC/OS-III port developer.

## Arguments

None

## Returned Value

None

## Notes/Warnings

*Do not* call this function from the application.

**Example**

The code below calls an application-specific hook that the application programmer can define. The user can simply set the value of `OS_AppTimeTickHookPtr` to point to the desired hook function `OSTimeTickHook()` is called by `OSTimeTick()` which in turn calls `App_OS_TimeTickHook()` through the pointer `OS_AppTimeTickHookPtr`.

```
void App_OS_TimeTickHook (void)                                /* OS_APP_HOOKS.C      */
{
    /* Your code goes here! */
}

void App_OS_SetAllHooks (void)                                /* OS_APP_HOOKS.C      */
{
    CPU_SR_ALLOC();

    CPU_CRITICAL_ENTER();
    :
    OS_AppTimeTickHookPtr = App_OS_TimeTickHook;
    :
    CPU_CRITICAL_EXIT();
}

void OSTimeTickHook (void)                                    /* OS_CPU_C.C          */
{
    #if OS_CFG_APP_HOOKS_EN > 0u
        if (OS_AppTimeTickHookPtr != (OS_APP_HOOK_VOID)0) { /* Call application hook */
            (*OS_AppTimeTickHookPtr)();
        }
    #endif
}
```

# OSTmrCreate ()

```
void OSTmrCreate (OS_TMR          *p_tmr,  
                 CPU_CHAR         *p_name,  
                 OS_TICK          dly,  
                 OS_TICK          period,  
                 OS_OPT            opt,  
                 OS_TMR_CALLBACK_PTR p_callback,  
                 void             *p_callback_arg,  
                 OS_ERR           *p_err)
```

| File     | Called from | Code enabled by |
|----------|-------------|-----------------|
| OS_TMR.C | Task Only   | OS_CFG_TMR_EN   |

**OSTmrCreate()** allows the user to create a software timer. The timer can be configured to run continuously (opt set to **OS\_TMR\_OPT\_PERIODIC**), or only once (opt set to **OS\_TMR\_OPT\_ONE\_SHOT**). When the timer counts down to 0 (from the value specified in period), an optional “callback” function can be executed. The callback can be used to signal a task that the timer expired, or perform any other function. However, it is recommended to keep the callback function as short as possible.

The timer is created in the “stop” mode and therefore the user *must* call **OSTmrStart()** to actually start the timer. If configuring the timer for ONE-SHOT mode, and the timer expires, call **OSTmrStart()** to retrigger the timer, or **OSTmrDel()** to delete the timer if it is not necessary to retrigger it, or not use the timer anymore. Note: use the callback function to delete the timer if using the ONE-SHOT mode.

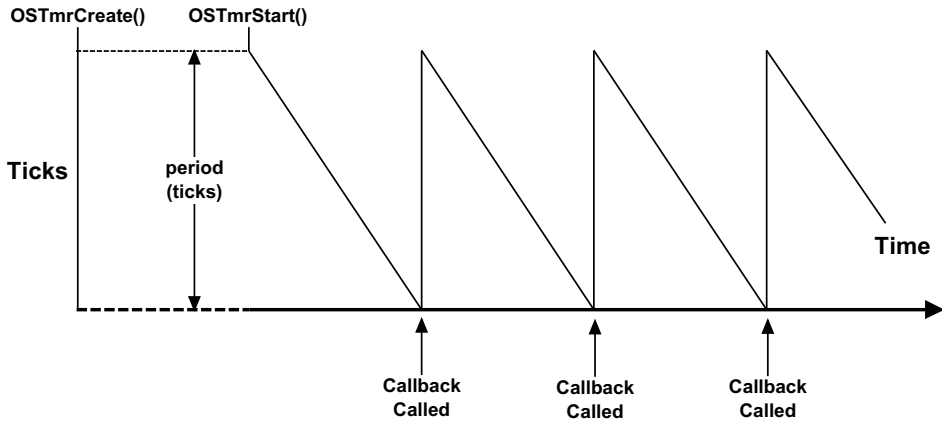

PERIODIC MODE (see "opt") -  $dly > 0, period > 0$

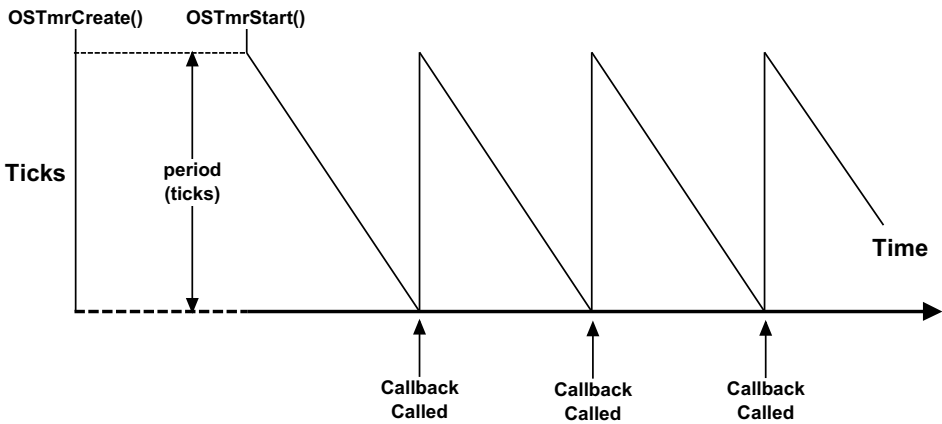

PERIODIC MODE (see "opt") - " == 0

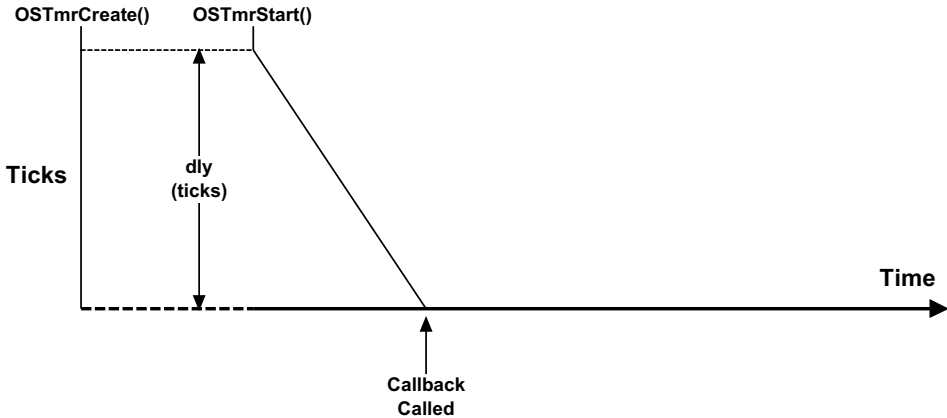

ONE-SHOT MODE (see “opt”) – `dly > 0`, `period == 0`

**Arguments**

`p_tmr` is a pointer to the timer-control block of the desired timer. It is assumed that storage for the timer will be allocated in the application. In other words, declare a “global” variable as follows, and pass a pointer to this variable to `OSTmrCreate()`:

```
OS_TMR MyTmr;
```

`p_name` is a pointer to an ASCII string (NUL terminated) used to assign a name to the timer. The name can be displayed by debuggers or µC/Probe.

`dly` specifies the initial delay (specified in timer tick units) used by the timer (see drawing above). If the timer is configured for ONE-SHOT mode, this is the timeout used. If the timer is configured for PERIODIC mode, this is the timeout to wait before the timer enters periodic mode. The units of this time depends on how often the user will call `OSTmrSignal()` (see `OSTimeTick()`). If `OSTmrSignal()` is called every 1/10 of a second (i.e., `OS_CFG_TMR_TASK_RATE_HZ` set to 10), `dly` specifies the number of 1/10 of a second before the delay expires. Note that the timer is *not* started when it is created.

**period** specifies the period repeated by the timer if configured for PERIODIC mode. Set the “period” to 0 when using ONE-SHOT mode. The units of time depend on how often `OSTmrSignal()` is called. If `OSTmrSignal()` is called every 1/10 of a second (i.e., `OS_CFG_TMR_TASK_RATE_HZ` set to 10), the period specifies the number of 1/10 of a second before the timer times out.

**opt** is used to specify whether the timer is to be ONE-SHOT or PERIODIC:

```
OS_OPT_TMR_ONE_SHOT  ONE-SHOT mode
OS_OPT_TMR_PERIODIC PERIODIC mode
```

**p\_callback** is a pointer to a function that will execute when the timer expires (ONE-SHOT mode), or every time the period expires (PERIODIC mode). A `NULL` pointer indicates that no action is to be performed upon timer expiration. The callback function must be declared as follows:

```
void MyCallback (OS_TMR *p_tmr, void *p_arg);
```

When called, the callback will be passed the pointer to the timer as well as an argument (`p_callback_arg`), which can be used to indicate to the callback what to do. Note that the user is allowed to call all of the timer related functions (i.e., `OSTmrCreate()`, `OSTmrDel()`, `OSTmrStateGet()`, `OSTmrRemainGet()`, `OSTmrStart()`, and `OSTmrStop()`) from the callback function.

*Do not* make blocking calls within callback functions.

**p\_callback\_arg** is an argument passed to the callback function when the timer expires (ONE-SHOT mode), or every time the period expires (PERIODIC mode). The pointer is declared as a “`void *`” so it can point to any data.

**p\_err** is a pointer to a variable that contains an error code returned by this function.

|                                     |   |
|-------------------------------------|---|
| <code>OS_ERR_NONE</code>            | if the call was successful.   |
| <code>OS_ERR_OBJ_CREATED</code>     | if the timer was already created  |
| <code>OS_ERR_OBJ_PTR_NULL</code>    | if <code>p_tmr</code> is a <code>NULL</code> pointer  |
| <code>OS_ERR_TMR_INVALID_DLY</code> | if specifying an invalid delay in ONE-SHOT mode. In other words, it is not allowed to delay for 0 in ONE-SHOT mode. |

|  |   |
|--|---|
| <code>OS_ERR_TMR_INVALID_PERIOD</code> | if specifying an invalid period in PERIODIC mode. It is not allowed to have a 0 period in PERIODIC. |
| <code>OS_ERR_TMR_INVALID_OPT</code>    | if not specifying a valid options.  |
| <code>OS_ERR_TMR_ISR</code>            | if calling this function from an ISR.   |

### **Returned Values**

None.

### **Notes/Warnings**

1. *Do not* call this function from an ISR.
2. The timer is *not* started when it is created. To start the timer, call `OSTmrStart()`.
3. *Do not* make blocking calls within callback functions.
4. Keep callback functions as short as possible.

## Example

```
OS_TMR  CloseDoorTmr;

void Task (void *p_arg)
{
    OS_ERR  err;

    (void)&p_arg;
    while (DEF_ON) {
        OSTmrCreate(&CloseDoorTmr,      /* p_tmr      */
                   "Door close"        /* p_name     */
                   10,                  /* dly        */
                   100,                 /* period     */
                   OS_OPT_TMR_PERIODIC, /* opt        */
                   DoorCloseFnct,      /* p_callback */
                   0,                   /* p_callback_arg */
                   &err);               /* p_err      */
        /* Check "err" */
    }
}

void DoorCloseFnct (void *p_arg)
{
    /* Close the door! */
}
```



# OSTmrDel ()

```
CPU_BOOLEAN OSTmrDel(OS_TMR *p_tmr,
                     OS_ERR *p_err)
```

| File     | Called from | Code enabled by                        |
|----------|-------------|--|
| OS_TMR.C | Task only   | OS_CFG_TMR_EN and<br>OS_CFG_TMR_DEL_EN |

OSTmrDel () allows the user to delete a timer. If a timer was running it will be stopped, then deleted. If the timer has already timed out and is therefore stopped, it will simply be deleted.

It is up to the user to delete unused timers. If deleting a timer, *Do not* reference it again.

## Arguments

**p\_tmr** is a pointer to the timer to be deleted.

**p\_err** a pointer to an error code and can be any of the following:

- OS\_ERR\_NONE if the timer was deleted.
- OS\_ERR\_OBJ\_TYPE if the user did not pass a pointer to a timer.
- OS\_ERR\_TMR\_INVALID if **p\_tmr** is a NULL pointer.
- OS\_ERR\_TMR\_ISR This function is called from an ISR, which is *not* allowed.
- OS\_ERR\_TMR\_INACTIVE **p\_tmr** is pointing to an inactive timer. In other words, this error appears when pointing to a timer that has been deleted or was not created.
- OS\_ERR\_TMR\_INVALID\_STATE the timer is in an invalid state.

## Returned Values

DEF\_TRUE if the timer was deleted, DEF\_FALSE if not.

### Notes/Warnings

1. Examine the return value to make sure what is received from this function is valid.
2. *Do not* call this function from an ISR.
3. When deleting a timer, *do not* reference it again.

### Example

```
OS_TMR  CloseDoorTmr;

void Task (void *p_arg)
{
    OS_ERR      err;
    CPU_BOOLEAN deleted;

    (void)&p_arg;
    while (DEF_ON) {
        deleted = OSTmrDel(&CloseDoorTmr,
                           &err);
        /* Check "err" */
    }
}
```

# OSTmrRemainGet ()

```
OS_TICK OSTmrRemainGet(OS_TMR *p_tmr,  
                        OS_ERR *p_err);
```

| File     | Called from | Code enabled by |
|----------|-------------|-----------------|
| OS_TMR.C | Task only   | OS_CFG_TMR_EN   |

OSTmrRemainGet() allows the user to obtain the time remaining (before timeout) of the specified timer. The value returned depends on the rate (in Hz) at which the timer task is signaled (see OS\_CFG\_TMR\_TASK\_RATE\_HZ). If OS\_CFG\_TMR\_TASK\_RATE\_HZ is set to 10, the value returned is the number of 1/10 of a second before the timer times out. If the timer has timed out, the value returned is 0.

## Arguments

**p\_tmr** is a pointer to the timer the user is inquiring about.

**p\_err** a pointer to an error code and can be any of the following:

|                          |   |
|--------------------------|---|
| OS_ERR_NONE              | if the function returned the time remaining for the timer.  |
| OS_ERR_OBJ_TYPE          | 'p_tmr' is not pointing to a timer.   |
| OS_ERR_TMR_INVALID       | if p_tmr is a NULL pointer.   |
| OS_ERR_TMR_ISR           | This function is called from an ISR, which is <i>not</i> allowed.   |
| OS_ERR_TMR_INACTIVE      | p_tmr is pointing to an inactive timer. In other words, this error will appear when pointing to a timer that has been deleted or was not created. |
| OS_ERR_TMR_INVALID_STATE | the timer is in an invalid state.   |

## Returned Values

The time remaining for the timer. The value returned depends on the rate (in Hz) at which the timer task is signaled (see OS\_CFG\_TMR\_TASK\_RATE\_HZ). If OS\_CFG\_TMR\_TASK\_RATE\_HZ is set to 10 the value returned is the number of 1/10 of a second before the timer times out. If specifying an invalid timer, the returned value will be 0. If the timer expired, the returned value will be 0.

### Notes/Warnings

1. Examine the returned error code to ensure the results from this function are valid.
2. *Do not* call this function from an ISR.

### Example

```
OS_TICK   TimeRemainToCloseDoor;
OS_TMR    CloseDoorTmr;

void Task (void *p_arg)
{
    OS_ERR   err;

    (void)&p_arg;
    while (DEF_ON) {
        TimeRemainToCloseDoor = OSTmrRemainGet(&CloseDoorTmr,
                                                &err);

        /* Check "err" */
    }
}
```

# OSTmrStart ()

```
CPU_BOOLEAN OSTmrStart (OS_TMR *p_tmr,  
                        OS_ERR *p_err);
```

| File     | Called from | Code enabled by |
|----------|-------------|-----------------|
| OS_TMR.C | Task        | OS_CFG_TMR_EN   |

OSTmrStart() allows the user to start (or restart) the countdown process of a timer. The timer *must* have previously been created.

## Arguments

**p\_tmr** is a pointer to the timer to start (or restart).

**p\_err** a pointer to an error code and can be any of the following:

|                          |  |
|--------------------------|--|
| OS_ERR_NONE              | if the timer was started.  |
| OS_ERR_OBJ_TYPE          | 'p_tmr' is not pointing to a timer.  |
| OS_ERR_TMR_INVALID       | if p_tmr is a NULL pointer.  |
| OS_ERR_TMR_INACTIVE      | p_tmr is pointing to an inactive timer. In other words, this error occurs if pointing to a timer that has been deleted or was not created. |
| OS_ERR_TMR_INVALID_STATE | the timer is in an invalid state.  |
| OS_ERR_TMR_ISR           | This function was called from an ISR, which is <i>not</i> allowed.   |

## Returned Values

DEF\_TRUE if the timer was started

DEF\_FALSE if an error occurred.

## Notes/Warnings

1. *Do not* call this function from an ISR.
2. The timer *must* have previously been created.

## Example

```
OS_TMR      CloseDoorTmr;

void Task (void *p_arg)
{
    OS_ERR      err;
    CPU_BOOLEAN status;

    (void)&p_arg;
    while (DEF_ON) {
        status = OSTmrStart(&CloseDoorTmr,
                            &err);
        /* Check "err" */
    }
}
```

# OSTmrStateGet ()

```
OS_STATE OSTmrStateGet(OS_TMR *p_tmr,
                       OS_ERR *p_err);
```

| File     | Called from | Code enabled by |
|----------|-------------|-----------------|
| OS_TMR.C | Task only   | OS_CFG_TMR_EN   |

OSTmrStateGet () allows the user to obtain the current state of a timer. A timer can be in one of four states:

|                        |  |
|------------------------|--|
| OS_TMR_STATE_UNUSED    | the timer has not been created                                     |
| OS_TMR_STATE_STOPPED   | the timer is created but has not yet started, or has been stopped. |
| OS_TMR_STATE_COMPLETED | the timer is in <i>one-shot</i> mode, and has completed its delay. |
| OS_TMR_STATE_RUNNING   | the timer is currently running                                     |

## Arguments

**p\_tmr** is a pointer to the timer that the user is inquiring about. This pointer is returned when the timer is created (see OSTmrCreate()).

**p\_err** a pointer to an error code and can be any of the following:

|                          |  |
|--------------------------|--|
| OS_ERR_NONE              | if the function returned the state of the timer.                   |
| OS_ERR_OBJ_TYPE          | p_tmr is not pointing to a timer.                                  |
| OS_ERR_TMR_INVALID       | if p_tmr is a NULL pointer.  |
| OS_ERR_TMR_INVALID_STATE | the timer is in an invalid state.                                  |
| OS_ERR_TMR_ISR           | This function was called from an ISR, which is <i>not</i> allowed. |

## Returned Values

The state of the timer (see description).

## Notes/Warnings

1. Examine the return value to ensure the results from this function are valid.
2. *Do not* call this function from an ISR.

## Example

```
OS_STATE  CloseDoorTmrState;
OS_TMR    CloseDoorTmr;

void Task (void *p_arg)
{
    OS_ERR  err;

    (void)&p_arg;
    while (DEF_ON) {
        CloseDoorTmrState = OSTmrStateGet(&CloseDoorTmr,
                                           &err);

        /* Check "err" */
    }
}
```



# OSTmrStop ()

```
CPU_BOOLEAN  OSTmrStop (OS_TMR  *p_tmr,  
                        OS_OPT   opt,  
                        void      *p_callback_arg,  
                        OS_ERR    *p_err)
```

| File     | Called from | Code enabled by |
|----------|-------------|-----------------|
| OS_TMR.C | Task        | OS_CFG_TMR_EN   |

**OSTmrStop()** allows the user to stop a timer. The user may execute the callback function of the timer when it is stopped, and pass this callback function a different argument than was specified when the timer was started. This allows the callback function to know that the timer was stopped since the callback argument can be set to indicate this (this is application specific). If the timer is already stopped, the callback function is not called.

## Arguments

**p\_tmr** is a pointer to the timer control block of the desired timer.

**opt** is used to specify options:

|                         |  |
|-------------------------|--|
| OS_OPT_TMR_NONE         | No option  |
| OS_OPT_TMR_CALLBACK     | Run the callback function with the argument specified when the timer was created.  |
| OS_OPT_TMR_CALLBACK_ARG | Run the callback function, but use the argument passed in <b>OSTmrStop()</b> instead of the one specified when the task was created. |

**p\_callback\_arg** is a new argument to pass the callback functions (see options above).

**p\_err** is a pointer to a variable that contains an error code returned by this function.

|                     |  |
|---------------------|--|
| OS_ERR_NONE         | if the call was successful.                        |
| OS_ERR_OBJ_TYPE     | if <b>p_tmr</b> is not pointing to a timer object. |
| OS_ERR_TMR_INACTIVE | the timer cannot be stopped since it is inactive.  |

|                                       |   |
|---------------------------------------|---|
| <code>OS_ERR_TMR_INVALID</code>       | When passing a <code>NULL</code> pointer for the <code>p_tmr</code> argument.               |
| <code>OS_ERR_TMR_INVALID_OPT</code>   | if the user did not specify a valid option.   |
| <code>OS_ERR_TMR_INVALID_STATE</code> | the timer is in an invalid state.   |
| <code>OS_ERR_TMR_ISR</code>           | if calling this function from an ISR.   |
| <code>OS_ERR_TMR_NO_CALLBACK</code>   | if the timer lacks a callback function. This should be specified when the timer is created. |
| <code>OS_ERR_TMR_STOPPED</code>       | if the timer is currently stopped.  |

### Returned Values

`DEF_TRUE` if the timer was stopped (even if it was already stopped).

`DEF_FALSE` if an error occurred.

### Notes/Warnings

1. Examine the returned error code to make ensure the results from this function are valid.
2. *Do not* call this function from an ISR.
3. The callback function is *not* called if the timer is already stopped.

### Example

```
OS_TMR  CloseDoorTmr;

void Task (void *p_arg)
{
    OS_ERR  err;

    (void)&p_arg;
    while (DEF_ON) {
        OSTmrStop(&CloseDoorTmr,
                 OS_TMR_OPT_CALLBACK,
                 (void *)0,
                 &err);
        /* Check "err" */
    }
}
```

# OSVersion()

CPU\_INT16U OSVersion (OS\_ERR \*p\_err);

| File      | Called from | Code enabled by |
|-----------|-------------|-----------------|
| OS_CORE.C | Task or ISR | N/A             |

OSVersion() obtains the current version of μC/OS-III.

## Arguments

**p\_err** is a pointer to a variable that contains an error code returned by this function. Currently, OSVersion() always return:

OS\_ERR\_NONE

## Returned Value

The version is returned as x.yy multiplied by 1000. For example, v3.00.0 is returned as 3000.

## Notes/Warnings

None

## Example

```
void TaskX (void *p_arg)
{
    CPU_INT16U  os_version;
    OS_ERR      err;

    while (DEF_ON) {
        :
        :
        os_version = OSVersion(&err); /* Obtain μC/OS-III's version */
        /* Check "err" */
        :
        :
    }
}
```



## B

 $\mu$ C/OS-III Configuration Manual

Three (3) files are used to configure  $\mu$ C/OS-III as highlighted in Figure B-1: `OS_CFG.H`, `OS_TYPE.H`, and `OS_CFG_APP.H`.

Table B-1 shows where these files are typically located on your on a computer.

| File                      | Directory  |
|---------------------------|--|
| <code>OS_CFG.H</code>     | <code>\Micrium\Software\uCOS-III\Cfg\Template</code> |
| <code>OS_CFG_APP.H</code> | <code>\Micrium\Software\uCOS-III\Cfg\Template</code> |
| <code>OS_TYPE.H</code>    | <code>\Micrium\Software\uCOS-III\Source</code>       |

Table B-1 **Configuration files and directories**

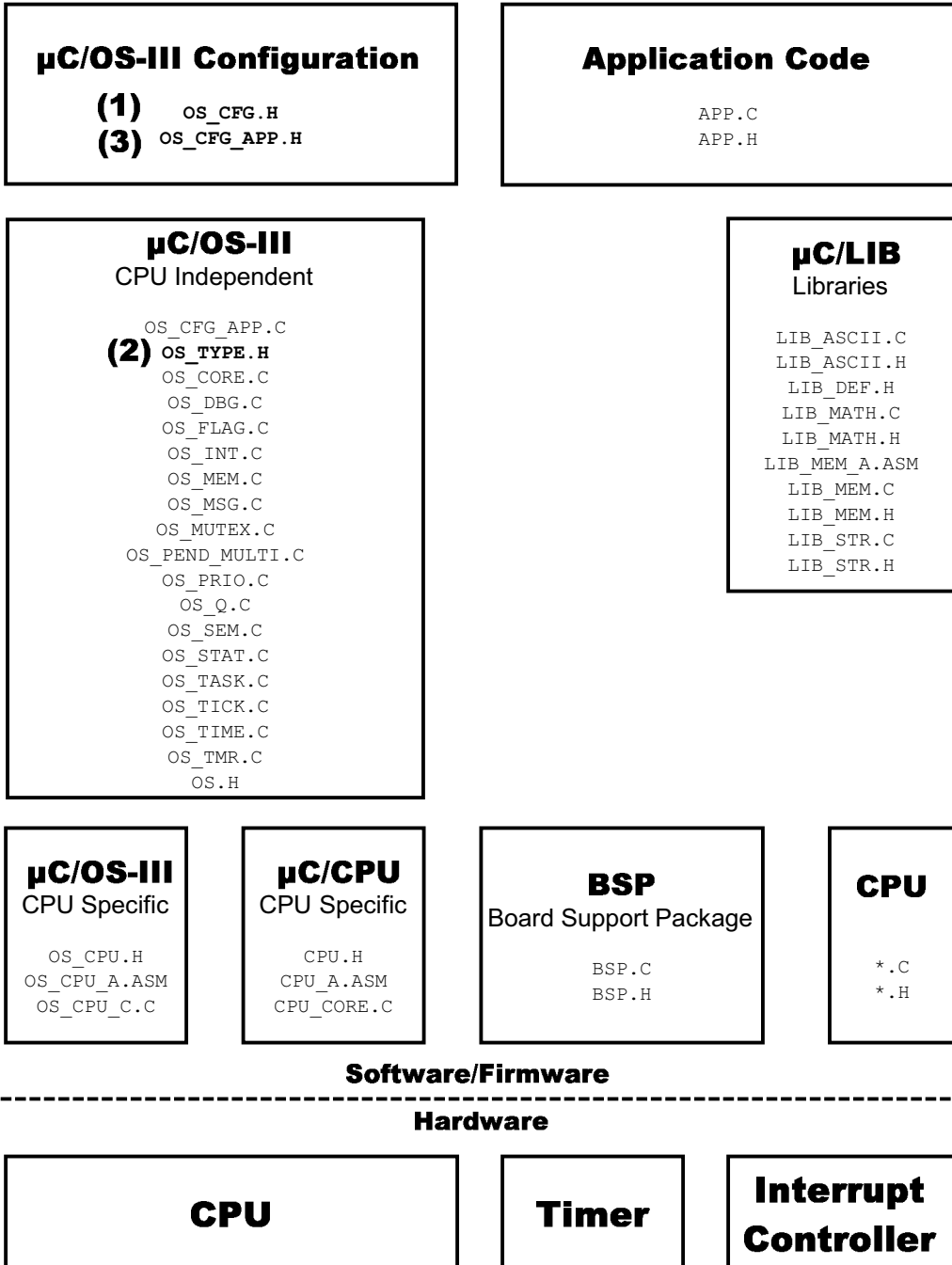

Figure B-1 Task pending on multiple objects

FB-1(1)     **μC/OS-III Features (OS\_CFG.H):**

OS\_CFG.H is used to determine which features are needed from μC/OS-III for an application (i.e., product). Specifically, this file allows a user to determine whether to include semaphores, mutexes, event flags, run-time argument checking, etc. If μC/OS-III is provided in linkable object form, the available features are determined in advanced.

If using a pre-compiled μC/OS-III library, make sure to use the same OS\_CFG.H file used to build this library so that all the data types properly match up.

FB-1(2)     **μC/OS-III Data Types (OS\_TYPE.H):**

OS\_TYPE.H establishes μC/OS-III-specific data types used when building an application. It specifies the size of variables used to represent task priorities, the size of a semaphore count, and more. This file contains recommended data types for μC/OS-III, however these can be altered to make better use of the CPU's natural word size. For example, on some 32-bit CPUs, it is better to declare boolean variables as 32-bit values for performance considerations, even though an 8-bit quantity is more space efficient (assuming performance is more important than footprint).

The port developer typically makes those decisions, since altering the contents of the file requires a deep understanding of the CPU and, most important, how data sizes affect μC/OS-III.

If using a pre-compiled μC/OS-III library, make sure to use the same OS\_TYPE.H file used to build this library so that all the data types properly match up.

FB-1(3)     **μC/OS-III Stacks, Pools and other data sizes (OS\_CFG\_APP.H):**

μC/OS-III can be configured at the application level through `#define` constants in OS\_CFG\_APP.H even if μC/OS-III is provided in linkable object form. The `#defines` allows a user to specify stack sizes for all μC/OS-III internal tasks: the idle task, statistic task, tick task, timer task, and the ISR handler task.

`OS_CFG_APP.H` also allows users to specify task priorities (except for the idle task since it is always the lowest priority), the tick rate, tick wheel size, the timer wheel size, and more.

You can simply copy `OS_CFG_APP.H` into the project directory and alter the contents of this file for the application. Once altered, simply re-compile `OS_CFG_APP.C`, and link the object file produced by the compiler with the rest of the  $\mu\text{C}/\text{OS-III}$  application. `OS_CFG_APP.C` “maps” the `#define` constants defined in `OS_CFG_APP.H` to variables (placed in code space, i.e., ROM) that  $\mu\text{C}/\text{OS-III}$  uses at initialization. This process is necessary to allow using  $\mu\text{C}/\text{OS-III}$  in linkable object form.  $\mu\text{C}/\text{OS-III}$  licensees will have full source code for  $\mu\text{C}/\text{OS-III}$ .

The contents of the three configuration files will be described in the following sections.



## **B-1 μC/OS-III FEATURES (OS\_CFG.H)**

Compile-time configuration allows users to determine which features to enable and those features that are not needed. This assumes that the user has the μC/OS-III source code. With compile-time configuration, the code and data sizes of μC/OS-III (i.e., its footprint) can be reduced by enabling only the desired functionality.

Compile-time configuration is accomplished by setting a number of **#define** constants in a file called **OS\_CFG.H** that the application is expected to provide. With the full source code for μC/OS-III, simply copy **OS\_CFG.H** into the application directory and change the copied file to satisfy the application's requirements. This way, **OS\_CFG.H** is not recreated from scratch.

The compile-time configuration **#defines** are listed below in alphabetic order and are not necessarily found in this order in **OS\_CFG.H**.

### **OS\_CFG\_APP\_HOOKS\_EN**

When set to 1, this **#define** specifies that application-defined hooks can be called from μC/OS-III's hooks. This allows the application code to extend the functionality of μC/OS-III. Specifically:

| <b>The μC/OS-III hook ...</b>   | <b>Calls the Application-define hook through...</b> |
|---------------------------------|---|
| <code>OSIdleTaskHook()</code>   | <code>OS_AppIdleTaskHookPtr</code>                  |
| <code>OSInitHook()</code>       | None  |
| <code>OSStatTaskHook()</code>   | <code>OS_AppStatTaskHookPtr</code>                  |
| <code>OSTaskCreateHook()</code> | <code>OS_AppTaskCreateHookPtr</code>                |
| <code>OSTaskDelHook()</code>    | <code>OS_AppTaskDelHookPtr</code>                   |
| <code>OSTaskReturnHook()</code> | <code>OS_AppTaskReturnHookPtr</code>                |
| <code>OSTaskSwHook()</code>     | <code>OS_AppTaskSwHookPtr</code>                    |
| <code>OSTimeTickHook()</code>   | <code>OS_AppTimeTickHookPtr</code>                  |

Application hook functions could be declared as shown in the code below.

```
void App_OS_TaskCreateHook (OS_TCB *p_tcb)
{
    /* Your code here */
}

void App_OS_TaskDelHook (OS_TCB *p_tcb)
{
    /* Your code here */
}

void App_OS_TaskReturnHook (OS_TCB *p_tcb)
{
    /* Your code here */
}

void App_OS_IdleTaskHook (void)
{
    /* Your code here */
}

void App_OS_StatTaskHook (void)
{
    /* Your code here */
}

void App_OS_TaskSwHook (void)
{
    /* Your code here */
}

void App_OS_TimeTickHook (void)
{
    /* Your code here */
}
```

It's also up to a user to set the value of the pointers so that they point to the appropriate functions as shown below. The pointers do not have to be set in `main()` but, set them after calling `OSInit()`.

```
void main (void)
{
    OS_ERR  err;

    OSInit(&err);
    :
    :
    OS_AppTaskCreateHookPtr = (OS_APP_HOOK_TCB )App_OS_TaskCreateHook;
    OS_AppTaskDelHookPtr   = (OS_APP_HOOK_TCB )App_OS_TaskDelHook;
    OS_AppTaskReturnHookPtr = (OS_APP_HOOK_TCB )App_OS_TaskReturnHook;
    OS_AppIdleTaskHookPtr  = (OS_APP_HOOK_VOID)App_OS_IdleTaskHook;
    OS_AppStatTaskHookPtr  = (OS_APP_HOOK_VOID)App_OS_StatTaskHook;
    OS_AppTaskSwHookPtr    = (OS_APP_HOOK_VOID)App_OS_TaskSwHook;
    OS_AppTimeTickHookPtr  = (OS_APP_HOOK_VOID)App_OS_TimeTickHook;
    :
    :
    OSStart(&err);
}
```

Note that not every hook function need to be defined, only the ones the user wants to place in the application code.

Also, if you don't intend to extend µC/OS-III's hook through these application hooks, set `OS_CFG_APP_HOOKS_EN` to 0 to save RAM (i.e., the pointers).

### **OS\_CFG\_ARG\_CHK\_EN**

`OS_CFG_ARG_CHK_EN` determines whether the user wants most of µC/OS-III functions to perform argument checking. When set to 1, µC/OS-III ensures that pointers passed to functions are non-NULL, that arguments passed are within allowable range, that options are valid, and more. When set to 0, `OS_CFG_ARG_CHK_EN` reduces the amount of code space and processing time required by µC/OS-III. Set `OS_CFG_ARG_CHK_EN` to 0 if you are certain that the arguments are correct.

µC/OS-III performs argument checking in over 40 functions. Therefore, you can save a few hundred bytes of code space by disabling this check. However, always enable argument checking until you are certain the code can be trusted.

### **OS\_CFG\_CALLED\_FROM\_ISR\_CHK\_EN**

`OS_CFG_CALLED_FROM_ISR_CHK_EN` determines whether most of µC/OS-III functions are to confirm that the function is not called from an ISR. In other words, most of the functions from µC/OS-III should be called by task-level code except “post” type functions (which can

also be called from ISRs). By setting this **#define** to 1  $\mu$ C/OS-III is told to make sure that functions that are only supposed to be called by tasks are not called by ISRs. It's highly recommended to set this **#define** to 1 until absolutely certain that the code is behaving correctly and that task-level functions are always called from tasks. Set this **#define** to 0 to save code space and, of course, processing time.

$\mu$ C/OS-III performs this check in approximately 50 functions. Therefore, you can save a few hundred bytes of code space by disabling this check.

#### **OS\_CFG\_DBG\_EN**

When set to 1, this **#define** adds ROM constants located in `OS_DBG.C` to help support kernel aware debuggers. Specifically, a number of named ROM variables can be queried by a debugger to find out about compiled-in options. For example, a debugger can find out the size of an `OS_TCB`,  $\mu$ C/OS-III's version number, the size of an event flag group (`OS_FLAG_GRP`), and much more.

#### **OS\_CFG\_FLAG\_EN**

`OS_CFG_FLAG_EN` enables (when set to 1) or disables (when set to 0) code generation of event flag services and data structures. This reduces the amount of code and data space needed when an application does not require event flags. When `OS_CFG_FLAG_EN` is set to 0, it is not necessary to enable or disable any of the other `OS_CFG_FLAG_xxx` **#define** constants in this section.

#### **OS\_CFG\_FLAG\_DEL\_EN**

`OS_CFG_FLAG_DEL_EN` enables (when set to 1) or disables (when set to 0) code generation of the function `OSFlagDel()`.

#### **OS\_CFG\_FLAG\_MODE\_CLR\_EN**

`OS_CFG_FLAG_MODE_CLR_EN` enables (when set to 1) or disables (when set to 0) code generation used to wait for event flags to be 0 instead of 1. Generally, wait for event flags to be set. However, the user may also want to wait for event flags to be clear and in this case, enable this option.

#### **OS\_CFG\_FLAG\_PEND\_ABORT\_EN**

`OS_CFG_FLAG_PEND_ABORT_EN` enables (when set to 1) or disables (when set to 0) code generation of the function `OSFlagPendAbort()`.

**OS\_CFG\_ISR\_POST\_DEFERRED\_EN**

When set to 1, OS\_CFG\_ISR\_POST\_DEFERRED\_EN reduces interrupt latency since interrupts are not disabled during most critical sections of code within μC/OS-III. Instead, the scheduler is locked during the processing of these critical sections. The advantage of setting OS\_CFG\_ISR\_POST\_DEFERRED\_EN to 1 is that interrupt latency is lower, however, ISR to task response is slightly higher. It is recommended to set

OS\_CFG\_ISR\_POST\_DEFERRED\_EN to 1 when enabling the following services, as setting this #define to 0 would potentially make interrupt latency unacceptably high:

| μC/OS-III Services                | Enabled by ...       |
|-----------------------------------|----------------------|
| Event Flags                       | OS_CFG_FLAG_EN       |
| Multiple Pend                     | OS_CFG_PEND_MULTI_EN |
| OS???Post() with broadcast        |                      |
| OS???Del() with OS_OPT_DEL_ALWAYS |                      |
| OS???PendAbort()                  |                      |

The compromise to make is:

OS\_CFG\_ISR\_POST\_DEFERRED\_EN set to 1  
Short interrupt latency, longer ISR-to-task response.

OS\_CFG\_ISR\_POST\_DEFERRED\_EN set to 0  
Long interrupt latency (see table above), shorter ISR-to-task response.

**OS\_CFG\_MEM\_EN**

OS\_CFG\_MEM\_EN enables (when set to 1) or disables (when set to 0) code generation of the μC/OS-III partition memory manager and its associated data structures. This feature allows users to reduce the amount of code and data space needed when an application does not require the use of memory partitions.

#### **OS\_CFG\_MUTEX\_EN**

OS\_CFG\_MUTEX\_EN enables (when set to 1) or disables (when set to 0) the code generation of all mutual exclusion semaphore services and data structures. This feature allows users to reduce the amount of code and data space needed when an application does not require the use of mutexes. When OS\_CFG\_MUTEX\_EN is set to 0, there is no need to enable or disable any of the other OS\_CFG\_MUTEX\_XXX #define constants in this section.

#### **OS\_CFG\_MUTEX\_DEL\_EN**

OS\_CFG\_MUTEX\_DEL\_EN enables (when set to 1) or disables (when set to 0) code generation of the function OSMutexDel().

#### **OS\_CFG\_MUTEX\_PEND\_ABORT\_EN**

OS\_CFG\_MUTEX\_PEND\_ABORT\_EN enables (when set to 1) or disables (when set to 0) code generation of the function OSMutexPendAbort().

#### **OS\_CFG\_OBJ\_TYPE\_CHK\_EN**

OS\_CFG\_OBJ\_TYPE\_CHK\_EN determines whether most of  $\mu$ C/OS-III functions should check to see if the function is manipulating the proper object. In other words, if attempting to post to a semaphore, is the user in fact passing a semaphore object or another object by mistake? It is recommended to set this #define to 1 until absolutely certain that the code is behaving correctly and the user code is always pointing to the proper objects. Set this #define to 0 to save code space as well as data space.  $\mu$ C/OS-III object type checking is done nearly 30 times, and it is possible to save a few hundred bytes of code space and processing time by disabling this check.

#### **OS\_CFG\_PEND\_MULTI\_EN**

This constant determines whether the code to support pending on multiple events (i.e., semaphores or message queues) will be enabled (1) or not (0).

#### **OS\_CFG\_PRIO\_MAX**

OS\_CFG\_PRIO\_MAX specifies the maximum number of priorities available in the application. Specifying OS\_CFG\_PRIO\_MAX to just the number of priorities the user intends to use, reduces the amount of RAM needed by  $\mu$ C/OS-III.

In  $\mu$ C/OS-III, task priorities can range from 0 (highest priority) to a maximum of 255 (lowest possible priority) when the data type OS\_PRIO is defined as a CPU\_INT08U. However, in

μC/OS-III, there is no practical limit to the number of available priorities. Specifically, if defining `OS_PRIO` as a `CPU_INT16U`, there can be up to 65536 priority levels. It is recommended to leave `OS_PRIO` defined as a `CPU_INT08U` and use only 256 different priority levels (i.e., 0..255), which is generally sufficient for every application. Always set the value of `OS_CFG_PRIO_MAX` to even multiples of 8 (8, 16, 32, 64, 128, 256, etc.). The higher the number of different priorities, the more RAM μC/OS-III will consume.

An application cannot create tasks with a priority number higher than or equal to

`OS_CFG_PRIO_MAX`. In fact, μC/OS-III reserves priority `OS_CFG_PRIO_MAX-1` for itself; `OS_CFG_PRIO_MAX-1` is reserved for the idle task `OS_IdleTask()`. Additionally, do not use priority 0 for an application since it is reserved by μC/OS-III's ISR handler task. The priorities of the application tasks can therefore take a value between 1 and `OS_CFG_PRIO_MAX-2` (inclusive).

To summarize, there are two priority levels to avoid in an application:

| Priority                       | Reserved by μC/OS-III for ...                       |
|--------------------------------|---|
| 0                              | The ISR Handler Task ( <code>OS_IntQTask()</code> ) |
| 1                              | Reserved  |
| 2                              | Reserved  |
| <code>OS_CFG_PRIO_MAX-2</code> | Reserved  |
| <code>OS_CFG_PRIO_MAX-1</code> | The idle task ( <code>OS_IdleTask()</code> )        |

**OS\_CFG\_Q\_EN**

`OS_CFG_Q_EN` enables (when set to 1) or disables (when set to 0) code generation of message queue services and data structures. This reduces the amount of code space needed when an application does not require the use of message queues. When `OS_CFG_Q_EN` is set to 0, do not enable or disable any of the other `OS_CFG_Q_XXX #define` constants in this section.

**OS\_CFG\_Q\_DEL\_EN**

`OS_CFG_Q_DEL_EN` enables (when set to 1) or disables (when set to 0) code generation of the function `OSQDel()`.

**OS\_CFG\_Q\_FLUSH\_EN**

OS\_CFG\_Q\_FLUSH\_EN enables (when set to 1) or disables (when set to 0) code generation of the function OSQFlush().

**OS\_CFG\_Q\_PEND\_ABORT\_EN**

OS\_CFG\_Q\_PEND\_ABORT\_EN enables (when set to 1) or disables (when set to 0) code generation of the function OSQPendAbort().

**OS\_CFG\_SCHED\_LOCK\_TIME\_MEAS\_EN**

This constant enables (when set to 1) or disables (when set to 0) code generation to measure the amount of time the scheduler is locked. This is useful when determining task latency.

**OS\_CFG\_SCHED\_ROUND\_ROBIN\_EN**

This constant enables (when set to 1) or disables (when set to 0) code generation for the round-robin feature of  $\mu$ C/OS-III.

**OS\_CFG\_SEM\_EN**

OS\_CFG\_SEM\_EN enables (when set to 1) or disables (when set to 0) code generation of the semaphore manager and associated data structures. This reduces the amount of code and data space needed when an application does not require the use of semaphores. When OS\_CFG\_SEM\_EN is set to 0, it is not necessary to enable or disable any of the other OS\_CFG\_SEM\_XXX #define constants in this section.

**OS\_CFG\_SEM\_DEL\_EN**

OS\_CFG\_SEM\_DEL\_EN enables (when set to 1) or disables (when set to 0) code generation of the function OSSemDel().

**OS\_CFG\_SEM\_PEND\_ABORT\_EN**

OS\_CFG\_SEM\_PEND\_ABORT\_EN enables (when set to 1) or disables (when set to 0) code generation of the function OSSemPendAbort().

**OS\_CFG\_SEM\_SET\_EN**

OS\_CFG\_SEM\_SET\_EN enables (when set to 1) or disables (when set to 0) code generation of the function OSSemSet().



### **OS\_CFG\_STAT\_TASK\_EN**

`OS_CFG_STAT_TASK_EN` specifies whether or not to enable  $\mu\text{C}/\text{OS-III}$ 's statistic task, as well as its initialization function. When set to 1, the statistic task `OS_StatTask()` and statistic task initialization function are enabled. `OS_StatTask()` computes the CPU usage of an application, stack usage of each task, the CPU usage of each task at run time and more.

When enabled, `OS_StatTask()` executes at a rate of `OS_CFG_STAT_TASK_RATE_HZ` (see `OS_CFG_APP.H`), and computes the value of `OSStatTaskCPUUsage`, which is a variable that contains the percentage of CPU used by the application. `OS_StatTask()` calls `OSStatTaskHook()` every time it executes so that the user can add their own statistics as needed. See `OS_STAT.C` for details on the statistic task. The priority of `OS_StatTask()` is configurable by the application code (see `OS_CFG_APP.H`).

`OS_StatTask()` also computes stack usage of each task created when the `#define`

`OS_CFG_STAT_TASK_STK_CHK_EN` is set to 1. In this case, `OS_StatTask()` calls `OSTaskStkChk()` for each task and the result is placed in the task's TCB. The `.StkFree` and `.StkUsed` field of the task's TCB represents the amount of free space (in bytes) and amount of used space, respectively.

When `OS_CFG_STAT_TASK_EN` is set to 0, all variables used by the statistic task are not declared (see `OS.H`). This, of course, reduces the amount of RAM needed by  $\mu\text{C}/\text{OS-III}$  when not enabling the statistic task. When setting `OS_CFG_STAT_TASK_EN` to 1, statistics will be determined at a rate of `OS_CFG_STAT_TASK_RATE_HZ` (see `OS_CFG_APP.H`).

### **OS\_CFG\_STAT\_TASK\_STK\_CHK\_EN**

This constant allows the statistic task to call `OSTaskStkChk()` for each task created. For this to happen, `OS_CFG_STAT_TASK_EN` needs to be set to 1 (i.e., the statistic task needs to be enabled). However, call `OSStatStkChk()` from one of the tasks to obtain this information about the task(s).

### **OS\_CFG\_STK\_SIZE\_MIN**

This `#define` specifies the minimum stack size (in `CPU_STK` elements) for each task. This is used by  $\mu\text{C}/\text{OS-III}$  to verify that sufficient stack space is provided for when each task is created. Suppose the full context of a processor consists of 16 registers of 32 bits. Also, suppose `CPU_STK` is declared as being of type `CPU_INT32U`, at a bare minimum, set `OS_CFG_STK_SIZE_MIN` to 16. However, it would be quite unwise to not accommodate for

storage of local variables, function call returns, and possibly nested ISRs. Refer to the “port” of the processor used to see how to set this minimum. Again, this is a safeguard to make sure task stacks have sufficient stack space.

**OS\_CFG\_TASK\_CHANGE\_PRIO\_EN**

OS\_CFG\_TASK\_CHANGE\_PRIO\_EN enables (when set to 1) or disables (when set to 0) code generation of the function OSTaskChangePrio().

**OS\_CFG\_TASK\_DEL\_EN**

OS\_CFG\_TASK\_DEL\_EN enables (when set to 1) or disables (when set to 0) code generation of the function OSTaskDel().

**OS\_CFG\_TASK\_Q\_EN**

OS\_CFG\_TASK\_Q\_EN enables (when set to 1) or disables (when set to 0) code generation of the OSTaskQXXX() functions used to send and receive messages directly to/from tasks and ISRs. Sending messages directly to a task is more efficient than sending messages using a message queue because there is no pend list associated with messages sent to a task.

**OS\_CFG\_TASK\_Q\_PEND\_ABORT\_EN**

OS\_CFG\_TASK\_Q\_PEND\_ABORT\_EN enables (when set to 1) or disables (when set to 0) code generation of code for the function OSTaskQPendAbort().

**OS\_CFG\_TASK\_PROFILE\_EN**

This constant allows variables to be allocated in each task’s OS\_TCB to hold performance data about each task. If OS\_CFG\_TASK\_PROFILE\_EN is set to 1, each task will have a variable to keep track of the number of times a task is switched to, the task execution time, the percent CPU usage of the task relative to the other tasks and more. The information made available with this feature is highly useful when debugging, but requires extra RAM.

**OS\_CFG\_TASK\_REG\_TBL\_SIZE**

This constant allows each task to have task context variables. Use task variables to store such elements as “errno”, task identifiers and other task-specific values. The number of variables that a task contains is set by this constant. Each variable is identified by a unique identifier from 0 to OS\_CFG\_TASK\_REG\_TBL\_SIZE-1. Also, each variable is declared as having an OS\_REG data type (see OS\_TYPE.H). If OS\_REG is a CPU\_INT08U, all variables in this table are of this type.

**OS\_CFG\_TASK\_SEM\_PEND\_ABORT\_EN**

OS\_CFG\_TASK\_SEM\_PEND\_ABORT\_EN enables (when set to 1) or disables (when set to 0) code generation of code for the function OSTaskSemPendAbort().

**OS\_CFG\_TASK\_SUSPEND\_EN**

OS\_CFG\_TASK\_SUSPEND\_EN enables (when set to 1) or disables (when set to 0) code generation of the functions OSTaskSuspend() and OSTaskResume(), which allows the application to explicitly suspend and resume tasks, respectively. Suspending and resuming a task is useful when debugging, especially if calling these functions via a terminal interface at run time.

**OS\_CFG\_TIME\_DLY\_HMSM\_EN**

OS\_CFG\_TIME\_DLY\_HMSM\_EN enables (when set to 1) or disables (when set to 0) the code generation of the function OSTimeDlyHMSM(), which is used to delay a task for a specified number of hours, minutes, seconds, and milliseconds.

**OS\_CFG\_TIME\_DLY\_RESUME\_EN**

OS\_CFG\_TIME\_DLY\_RESUME\_EN enables (when set to 1) or disables (when set to 0) the code generation of the function OSTimeDlyResume().

**OS\_CFG\_TMR\_EN**

Enables (when set to 1) or disables (when set to 0) the code generation of timer management services.

**OS\_CFG\_TMR\_DEL\_EN**

OS\_CFG\_TMR\_DEL\_EN enables (when set to 1) or disables (when set to 0) the code generation of the function OSTmrDel().

**B-2 DATA TYPES (OS\_TYPE.H)**

OS\_TYPE.H contains the data types used by μC/OS-III, which should only be altered by the implementer of the μC/OS-III port. If the user only has access to a compiled μC/OS-III library or object code, make sure to use the same OS\_TYPE.H used to compile the library in order to use μC/OS-III. Of course, if there is access to the source code of both the port and μC/OS-III, you can alter the contents of OS\_TYPE.H. However, it is important to understand how each of the data types that are being changed will affect the operation of μC/OS-III-based applications.

The reason to change `OS_TYPE.H` is that processors may work better with specific word sizes. For example, a 16-bit processor will likely be more efficient at manipulating 16-bit values and a 32-bit processor more comfortable with 32-bit values, even at the cost of extra RAM. In other words, the user may need to choose between processor performance and RAM footprint.

If changing “any” of the data types, copy `OS_TYPE.H` in the project directory and change that file (not the original `OS_TYPE.H` that comes with the  $\mu$ C/OS-III release). Of course, to change the data types, the user must have the full source code for  $\mu$ C/OS-III and recompile all of the code using the new data types.

Recommended data type sizes are specified in comments in `OS_TYPE.H`.

### **B-3 $\mu$ C/OS-III STACKS, POOLS AND OTHER (`OS_CFG_APP.H`)**

$\mu$ C/OS-III allows the user to configure the sizes of the idle task stack, statistic task stack, message pool, tick wheel, timer wheel, debug tables, and more. This is done through `OS_CFG_APP.H`.

#### **`OS_CFG_TASK_STK_LIMIT_PCT_EMPTY`**

This `#define` sets the position (as a percentage to empty) of the stack limit for the idle, statistic, tick, interrupt queue handler, and timer tasks stacks. In other words, the amount of space to leave before the stack is empty. For example if the stack contains 1000 `CPU_STK` entries and the user declares `OS_CFG_TASK_STK_LIMIT_PCT_EMPTY` to 10, the stack limit will be set when the stack reaches 90% full, or 10% empty.

If the stack of the processor grows from high memory to low memory, the limit would be set towards the “base address” of the stack, i.e., closer to element 0 of the stack.

If the processor used does not offer automatic stack limit checking, set this `#define` to 0.

#### **`OS_CFG_IDLE_TASK_STK_SIZE`**

This `#define` sets the size of the idle task’s stack as follows:

```
CPU_STK OSCfg_IdleTaskStk[OS_CFG_IDLE_TASK_STK_SIZE];
```

Note that the stack size needs to be at least greater than `OS_CFG_STK_SIZE_MIN`.

### **OS\_CFG\_INT\_Q\_SIZE**

If `OS_CFG_ISR_POST_DEFERRED_EN` is set to 1 (see `OS_CFG.H`), this `#define` specifies the number of entries that can be placed in the interrupt queue. The size of this queue depends on how many interrupts could occur in the time it takes to process interrupts by the ISR Handler Task. The size also depends on whether or not to allow interrupt nesting. A good start point is approximately 10 entries.

### **OS\_CFG\_INT\_Q\_TASK\_STK\_SIZE**

If `OS_CFG_ISR_POST_DEFERRED_EN` is set to 1 (see `OS_CFG.H`) then this `#define` sets the size of the ISR handler task's stack as follows:

```
CPU_STK OSCfg_IntQTaskStk[OS_CFG_INT_Q_TASK_STK_SIZE];
```

Note that the stack size needs to be at least greater than `OS_CFG_STK_SIZE_MIN`.

### **OS\_CFG\_ISR\_STK\_SIZE**

This specifies the size of `μC/OS-III`'s interrupt stack (in `CPU_STK` elements, see `OS_TYPE.H`). Note that the stack size needs to accommodate for worst case interrupt nesting, assuming the processor supports interrupt nesting.

### **OS\_CFG\_MSG\_POOL\_SIZE**

This entry specifies the number of `OS_MSGs` available in the pool of `OS_MSGs`. The size is specified in number of `OS_MSG` elements. The message pool is declared in `OS_CFG_APP.C` as follows:

```
OS_MSG OSCfg_MsgPool[OS_CFG_MSG_POOL_SIZE];
```

### **OS\_CFG\_STAT\_TASK\_PRIO**

This `#define` allows a user to specify the priority assigned to the `μC/OS-III` statistic task. It is recommended to make this task a very low priority and possibly even one priority level just above the idle task, or, `OS_CFG_PRIO_MAX-2`.

### **OS\_CFG\_STAT\_TASK\_RATE\_HZ**

This `#define` defines the execution rate (in Hz) of the statistic task. It is recommended to make this rate an even multiple of the tick rate (see `OS_CFG_TICK_RATE_HZ`).

### **OS\_CFG\_STAT\_TASK\_STK\_SIZE**

This `#define` sets the size of the statistic task's stack as follows:

```
CPU_STK OSCfg_StatTaskStk[OS_CFG_STAT_TASK_STK_SIZE];
```

Note that the stack size needs to be at least greater than `OS_CFG_STK_SIZE_MIN`.

### **OS\_CFG\_TICK\_RATE\_HZ**

This `#define` specifies the rate in Hertz of  $\mu\text{C}/\text{OS-III}$ 's tick interrupt. The tick rate should be set between 10 and 1000 Hz. The higher the rate, the more overhead it will impose on the processor. The desired rate depends on the granularity required for time delays and timeouts.

### **OS\_CFG\_TICK\_TASK\_PRIO**

This `#define` specifies the priority to assign to the  $\mu\text{C}/\text{OS-III}$  tick task. It is recommended to make this task a fairly high priority, but it does not need to be the highest. The priority assigned to this task must be greater than 0 and less than `OS_CFG_PRIO_MAX-1`.

### **OS\_CFG\_TICK\_TASK\_STK\_SIZE**

This entry specifies the size of  $\mu\text{C}/\text{OS-III}$ 's tick task stack (in `CPU_STK` elements). Note that the stack size must be at least greater than `OS_CFG_STK_SIZE_MIN`.

### **OS\_CFG\_TICK\_WHEEL\_SIZE**

This `#define` determines the number of entries in the `OSTickWheel[]` table. This "wheel" reduces the number of tasks to be updated by the tick task. The size of the wheel should be a fraction of the number of tasks expected in the application.

This value should be a number between 4 and 1024. Task management overhead is somewhat determined by the size of the wheel. A large number of entries might reduce the overhead for tick management but would require more RAM. Each entry requires a pointer and a counter of the number of entries in each "spoke" of the wheel. This counter is typically a 16-bit value. It is recommended that `OS_CFG_TICK_WHEEL_SIZE` not be a multiple of the tick rate. If the application has many tasks, a large wheel size is recommended. As a starting value, use a prime number (3, 5, 7, 11, 13, 17, 19, 23, etc.).

**OS\_CFG\_TMR\_TASK\_PRIO**

This `#define` allows a user to specify the priority to assign to the μC/OS-III timer task. It is recommended to make this task a medium-to-low priority, depending on how fast the timer task will execute (see `OS_CFG_TMR_TASK_RATE_HZ`), how many timers running in the application, and the size of the timer wheel, etc. The priority assigned to this task must be greater than 0 and less than `OS_CFG_PRIO_MAX-1`.

Start with these simple rules:

- The faster the timer rate, the higher the priority to assign to this task.
- The higher the timer wheel size, the higher the priority to assign this task.
- The higher the number of timers in the system, the lower the priority.

In other words:

|                       |                 |
|-----------------------|-----------------|
| High Timer Rate       | Higher Priority |
| High Timer Wheel Size | Higher Priority |
| High Number of Timers | Lower Priority  |

**OS\_CFG\_TMR\_TASK\_RATE\_HZ**

This `#define` specifies the rate in Hertz of μC/OS-III's timer task. The timer task rate should typically be set to 10 Hz. However, timers can run at a faster rate at the price of higher processor overhead. Note that `OS_CFG_TMR_TASK_RATE_HZ` MUST be an integer multiple of `OS_CFG_TICK_TASK_RATE_HZ`. In other words, if setting `OS_CFG_TICK_TASK_RATE_HZ` to 1000, do not set `OS_CFG_TMR_TASK_RATE_HZ` to 11 since 90.91 ticks would be required for every timer update, and 90.91 is not an integer multiple. Use approximately 10 Hz in this example.

**OS\_CFG\_TMR\_TASK\_STK\_SIZE**

This `#define` sets the size of the timer task's stack as follows:

```
CPU_STK OSCfg_TmrTaskStk[OS_CFG_TMR_TASK_STK_SIZE];
```

Note that the stack size needs to be at least greater than `OS_CFG_STK_SIZE_MIN`.

**OS\_CFG\_TMR\_WHEEL\_SIZE**

Timers are updated using a rotating wheel mechanism. This “wheel” reduces the number of timers to be updated by the timer manager task. The size of the wheel should be a fraction of the number of timers in the application.

This value should be a number between 4 and 1024. Timer management overhead is somewhat determined by the size of the wheel. A large number of entries might reduce the overhead for timer management but would require more RAM. Each entry requires a pointer and a counter of the number of entries in each “spoke” of the wheel. This counter is typically a 16-bit value. It is recommended that this value *not* be a multiple of the tick rate. If an application has many timers a large wheel size is recommended. As a starting value, use a prime number (3, 5, 7, 11, 13, 17, 19, 23, etc.).



# C

## Migrating from $\mu\text{C}/\text{OS-II}$ to $\mu\text{C}/\text{OS-III}$

$\mu\text{C}/\text{OS-III}$  is a completely new real-time kernel with roots in  $\mu\text{C}/\text{OS-II}$ . Portions of the  $\mu\text{C}/\text{OS-II}$  Application Programming Interface (API) function names are the same, but the arguments passed to the functions have, in some places, drastically changed.

Appendix C explains several differences between the two real-time kernels. However, access to  $\mu\text{C}/\text{OS-II}$  and  $\mu\text{C}/\text{OS-III}$  source files best highlights the differences.

Table C-1 is a feature-comparison chart for  $\mu\text{C}/\text{OS-II}$  and  $\mu\text{C}/\text{OS-III}$ .

| <b>Feature</b>  | <b><math>\mu\text{C}/\text{OS-II}</math></b> | <b><math>\mu\text{C}/\text{OS-III}</math></b> |
|---|--|---|
| Year of introduction                                      | 1998/2002                                    | 2009  |
| Book  | Yes  | Yes   |
| Source code available (Licensees only)                    | Yes  | Yes   |
| Preemptive Multitasking                                   | Yes  | Yes   |
| Maximum number of tasks                                   | 255  | Unlimited                                     |
| Number of tasks at each priority level                    | 1  | Unlimited                                     |
| Round Robin Scheduling                                    | No   | Yes   |
| Semaphores  | Yes  | Yes   |
| Mutual Exclusion Semaphores (Nestable)                    | Yes  | Yes   |
| Event Flags   | Yes  | Yes   |
| Message Mailboxes (not needed)                            | Yes  | No  |
| Message Queues  | Yes  | Yes   |
| Fixed Sized Memory Management                             | Yes  | Yes   |
| Signal a task without requiring a semaphore               | No   | Yes   |
| Send messages to a task without requiring a message queue | No   | Yes   |
| Software Timers   | Yes  | Yes   |
| Task suspend/resume (Nestable)                            | Yes  | Yes   |
| Deadlock prevention                                       | Yes  | Yes   |
| Scalable  | Yes  | Yes   |
| Code Footprint  | 6K to 26K                                    | 6K to 20K                                     |
| Data Footprint  | 1K+  | 1K+   |
| ROMable   | Yes  | Yes   |
| Run-time configurable                                     | No   | Yes   |
| Feature   | $\mu\text{C}/\text{OS-II}$                   | $\mu\text{C}/\text{OS-III}$                   |
| Compile-time configurable                                 | Yes  | Yes   |

| <b>Feature</b>   | <b><math>\mu\text{C}/\text{OS-II}</math></b> | <b><math>\mu\text{C}/\text{OS-III}</math></b> |
|--|--|---|
| ASCII names for each kernel object   | Yes  | Yes   |
| Interrupt Latency  | 1200~  | < 1000~                                       |
| Pend on multiple objects   | Yes  | Yes   |
| Task registers   | Yes  | Yes   |
| Built-in performance measurements  | Limited                                      | Extensive                                     |
| User definable hook functions  | Yes  | Yes   |
| Time stamps on posts   | No   | Yes   |
| Built-in Kernel Awareness support  | Yes  | Yes   |
| Optimizable Scheduler in assembly language                                 | No   | Yes   |
| Tick handling at task level  | No   | Yes   |
| Source code available  | Yes  | Yes   |
| Number of services   | ~90  | ~70   |
| MISRA-C:1998 (except 5 rules)  | Yes  | N/A   |
| MISRA-C:2004 (except 5 rules)  | No   | Yes   |
| DO178B Level A and EUROCAE ED-12B  | Yes  | In progress                                   |
| Medical FDA pre-market notification (510(k)) and pre-market approval (PMA) | Yes  | In progress                                   |
| SIL3/SIL4 IEC for transportation and nuclear systems                       | Yes  | In progress                                   |
| IEC-61508  | Yes  | In progress                                   |

Table C-1  $\mu\text{C}/\text{OS-II}$  and  $\mu\text{C}/\text{OS-III}$  features comparison chart

## C-1 DIFFERENCES IN SOURCE FILE NAMES AND CONTENTS

Table C-2 shows the source files used in both kernels. Note that a few of the files have the same or similar name. Even though  $\mu\text{C}/\text{OS-III}$  has more source files, the final compiled footprint is actually smaller for a full configuration.

| $\mu\text{C}/\text{OS-II}$ | $\mu\text{C}/\text{OS-III}$ | Note |
|----------------------------|-----------------------------|------|
|                            | OS_APP_HOOKS.C              | (1)  |
|                            | OS_CFG_APP.C                | (2)  |
|                            | OS_CFG_APP.H                | (3)  |
| OS_CFG_R.H                 | OS_CFG.H                    | (4)  |
| OS_CORE.C                  | OS_CORE.C                   |      |
| OS_CPU.H                   | OS_CPU.H                    | (5)  |
| OS_CPU_A.ASM               | OS_CPU_A.ASM                | (5)  |
| OS_CPU_C.C                 | OS_CPU_C.C                  | (5)  |
| OS_DBG_R.C                 | OS_DBG.C                    | (6)  |
| OS_FLAG.C                  | OS_FLAG.C                   |      |
|                            | OS_INT.C                    | (7)  |
|                            | OS_PEND_MULTI.C             | (8)  |
|                            | OS_PRIO.C                   | (9)  |
| OS_MBOX.C                  |                             | (10) |
| OS_MEM.C                   | OS_MEM.C                    |      |
|                            | OS_MSG.C                    | (11) |
| OS_MUTEX.C                 | OS_MUTEX.C                  |      |
| OS_Q.C                     | OS_Q.C                      |      |
| OS_SEM.C                   | OS_SEM.C                    |      |
|                            | OS_STAT.C                   | (12) |
| OS_TASK.C                  | OS_TASK.C                   |      |
| OS_TIME.C                  | OS_TIME.C                   |      |
| OS_TMR.C                   | OS_TMR.C                    |      |
|                            | OS_VAR.C                    | (13) |
|                            | OS_TYPE.H                   | (14) |
| UCOS_II.H                  | OS.H                        | (15) |

Table C-2  $\mu\text{C}/\text{OS-II}$  and  $\mu\text{C}/\text{OS-III}$  files

- TC-2(1)  $\mu\text{C}/\text{OS-II}$  does not have this file, which is now provided for convenience so the user can add application hooks. Copy this file to the application directory and edit the contents of the file.
- TC-2(2) `OS_CFG_APP.C` did not exist in  $\mu\text{C}/\text{OS-II}$ . This file needs to be added to a project build for  $\mu\text{C}/\text{OS-III}$ .
- TC-2(3) In  $\mu\text{C}/\text{OS-II}$ , all configuration constants were placed in `OS_CFG.H`. In  $\mu\text{C}/\text{OS-III}$ , some of the configuration constants are placed in this file, while others are in `OS_CFG.H`. `OS_CFG_APP.H` contains application-specific configurations such as the size of the idle task stack, tick rate, and others.
- TC-2(4) In  $\mu\text{C}/\text{OS-III}$ , `OS_CFG.H` is reserved for configuring certain features of the kernel. For example, are any of the semaphore services required, and will the application have fixed-sized memory partition management?
- TC-2(5) These are the port files and a few variables and functions will need to be changed when using a  $\mu\text{C}/\text{OS-II}$  port as a starting point for the  $\mu\text{C}/\text{OS-III}$  port.

| <b><math>\mu\text{C}/\text{OS-II}</math> variable changes to ...</b> | <b>... in <math>\mu\text{C}/\text{OS-III}</math></b> |
|--|--|
| <code>OSIntNesting</code>  | <code>OSIntNestingCtr</code>                         |
| <code>OSTCBCur</code>  | <code>OSTCBCurPtr</code>                             |
| <code>OSTCBHighRdy</code>  | <code>OSTCBHighRdyPtr</code>                         |
| <b><math>\mu\text{C}/\text{OS-II}</math> function changes to ...</b> | <b>... in <math>\mu\text{C}/\text{OS-III}</math></b> |
| <code>OSInitHookBegin()</code>                                       | <code>OSInitHook()</code>                            |
| <code>OSInitHookEnd()</code>   | N/A  |
| <code>OSTaskStatHook()</code>  | <code>OSStatTaskHook()</code>                        |
| <code>OSTaskIdleHook()</code>  | <code>OSIdleTaskHook()</code>                        |
| <code>OSTCBInitHook()</code>   | N/A  |
| <code>OSTaskStkInit()</code>   | <code>OSTaskStkInit()</code>                         |

The name of `OSTaskStkInit()` is the same but it is listed here since the code for it needs to be changed slightly as several arguments passed to this function are different. Specifically, instead of passing the top-of-stack as in  $\mu\text{C}/\text{OS-II}$ , `OSTaskStkInit()` is passed the base address and the size of the task stack.

- TC-2(6) In  $\mu\text{C}/\text{OS-III}$ , `OS_DBG.C` should always be part of the build. In  $\mu\text{C}/\text{OS-II}$ , the equivalent file (`OS_DBG_R.C`) was optional.
- TC-2(7) `OS_INT.C` contains the code for the Interrupt Queue handler, which is a new feature in  $\mu\text{C}/\text{OS-III}$ , allowing post calls from ISRs to be deferred to a task-level handler. This is done to reduce interrupt latency (see Chapter 9, “Interrupt Management” on page 157).
- TC-2(8) Both kernels allow tasks to pend on multiple kernel objects. In  $\mu\text{C}/\text{OS-II}$ , this code is found in `OS_CORE.C`, while in  $\mu\text{C}/\text{OS-III}$ , the code is placed in a separate file.
- TC-2(9) The code to determine the highest priority ready-to-run task is isolated in  $\mu\text{C}/\text{OS-III}$  and placed in `OS_PRIO.C`. This allows the port developer to replace this file by an assembly language equivalent file, especially if the CPU used supports certain bit manipulation instructions and a count leading zeros (CLZ) instruction.
- TC-2(10)  $\mu\text{C}/\text{OS-II}$  provides message mailbox services. A message mailbox is identical to a message queue of size one.  $\mu\text{C}/\text{OS-III}$  does not have these services since they can be easily emulated by message queues.
- TC-2(11) Management of messages for message queues is encapsulated in `OS_MSG.C` in  $\mu\text{C}/\text{OS-III}$ .
- TC-2(12) The statistics task and its support functions have been extracted out of `OS_CORE.C` and placed in `OS_STAT.C` for  $\mu\text{C}/\text{OS-III}$ .
- TC-2(13) All the  $\mu\text{C}/\text{OS-III}$  variables are instantiated in a file called `OS_VAR.C`.
- TC-2(14) In  $\mu\text{C}/\text{OS-III}$ , the size of most data types is better adapted to the CPU architecture used. In  $\mu\text{C}/\text{OS-II}$ , the size of a number of these data types was assumed.
- TC-2(15) In  $\mu\text{C}/\text{OS-II}$ , the main header file is called `UCOS_II.H`. In  $\mu\text{C}/\text{OS-III}$ , it is renamed to `OS.H`.

## C-2 CONVENTION CHANGES

There are a number of convention changes from  $\mu\text{C}/\text{OS-II}$  to  $\mu\text{C}/\text{OS-III}$ . The most notable is the use of CPU-specific data types. Table C-3 shows the differences between the data types used in both kernels.

| $\mu\text{C}/\text{OS-II}$ ( <b>os_cpu.h</b> ) | $\mu\text{C}/\text{CPU}$ ( <b>cpu.h</b> ) | Note |
|--|---|------|
| BOOLEAN  | CPU_BOOLEAN                               |      |
| INT8S  | CPU_INT8S                                 |      |
| INT8U  | CPU_INT8U                                 |      |
| INT16S   | CPU_INT16S                                |      |
| INT16U   | CPU_INT16U                                |      |
| INT32S   | CPU_INT32S                                |      |
| INT32U   | CPU_INT32U                                |      |
| OS_STK   | CPU_OS_STK                                | (1)  |
| OS_CPU_SR                                      | CPU_SR                                    | (2)  |
| $\mu\text{C}/\text{OS-II}$ ( <b>os_cfg.h</b> ) | $\mu\text{C}/\text{CPU}$ ( <b>cpu.h</b> ) |      |
| OS_STK_GROWTH                                  | CPU_CFG_STK_GROWTH                        | (3)  |

Table C-3  $\mu\text{C}/\text{OS-II}$  vs.  $\mu\text{C}/\text{OS-III}$  basic data types

- TC-3(1) A task stack in  $\mu\text{C}/\text{OS-II}$  is declared as an **OS\_STK**, which is now replaced by a CPU specific data type **CPU\_STK**. These two data types are equivalent, except that defining the width of the CPU stack in  $\mu\text{C}/\text{CPU}$  makes more sense.
- TC-3(2) It also makes sense to declare the CPU's status register in  $\mu\text{C}/\text{CPU}$ .
- TC-3(3) Stack growth (high-to-low or low-to-high memory) is declared in  $\mu\text{C}/\text{CPU}$  since stack growth is a CPU feature and not an OS one.

Another convention change is the use of the acronym “**cfg**” which stands for configuration. Now, all **#define** configuration constants and variables have the “**CFG**” or “**Cfg**” acronym in them as shown in Table C-4. Table C-4 shows the configuration constants that have been moved from **OS\_CFG.H** to **OS\_CFG\_APP.H**. This is done because  $\mu$ C/OS-III is configurable at the application level instead of just at compile time as with  $\mu$ C/OS-II.

| <b><math>\mu</math>C/OS-II (OS_CFG.H)</b> | <b><math>\mu</math>C/OS-III (OS_CFG_APP.H)</b> | <b>Note</b> |
|---|--|-------------|
|   | OS_CFG_MSG_POOL_SIZE                           |             |
|   | OS_CFG_ISR_STK_SIZE                            |             |
|   | OS_CFG_TASK_STK_LIMIT_PCT_EMPTY                |             |
| OS_TASK_IDLE_STK_SIZE                     | OS_CFG_IDLE_TASK_STK_SIZE                      |             |
|   | OS_CFG_INT_Q_SIZE                              |             |
|   | OS_CFG_INT_Q_TASK_STK_SIZE                     |             |
|   | OS_CFG_STAT_TASK_PRIO                          |             |
|   | OS_CFG_STAT_TASK_RATE_HZ                       |             |
| OS_TASK_STAT_SIZE                         | OS_CFG_STAT_TASK_STK_SIZE                      |             |
| OS_TICKS_PER_SEC                          | OS_CFG_TICK_RATE_HZ                            | (1)         |
|   | OS_CFG_TICK_TASK_PRIO                          |             |
|   | OS_CFG_TICK_TASK_STK_SIZE                      |             |
|   | OS_CFG_TICK_WHEEL_SIZE                         |             |
|   | OS_CFG_TMR_TASK_PRIO                           |             |
| OS_TMR_CFG_TICKS_PER_SEC                  | OS_CFG_TMR_TASK_RATE_HZ                        |             |
| OS_TASK_TMR_STK_SIZE                      | OS_CFG_TMR_TASK_STK_SIZE                       |             |
| OS_TMR_CFG_WHEEL_SIZE                     | OS_CFG_TMR_WHEEL_SIZE                          |             |

Table C-4  $\mu$ C/OS-III uses “CFG” in configuration

TC-4(1) The very useful **OS\_TICKS\_PER\_SEC** in  $\mu$ C/OS-II was renamed to **OS\_CFG\_TICK\_RATE\_HZ** in  $\mu$ C/OS-III. The “**HZ**” indicates that this **#define** represents Hertz (i.e., ticks per second).

Table C-5 shows additional configuration constants added to **OS\_CFG.H**, while several  $\mu$ C/OS-II constants were either removed or renamed.



| $\mu$ C/OS-II (OS_CFG.H) | $\mu$ C/OS-III (OS_CFG.H)      | Note |
|--------------------------|--------------------------------|------|
| OS_APP_HOOKS_EN          | OS_CFG_APP_HOOKS_EN            |      |
| OS_ARG_CHK_EN            | OS_CFG_ARG_CHK_EN              |      |
|                          | OS_CFG_CALLED_FROM_ISR_CHK_EN  |      |
| OS_DEBUG_EN              | OS_CFG_DBG_EN                  | (1)  |
| OS_EVENT_MULTI_EN        | OS_CFG_PEND_MULTI_EN           |      |
| OS_EVENT_NAME_EN         |                                | (2)  |
|                          | OS_CFG_ISR_POST_DEFERRED_EN    |      |
| OS_MAX_EVENTS            |                                | (3)  |
| OS_MAX_FLAGS             |                                | (3)  |
| OS_MAX_MEM_PART          |                                | (3)  |
| OS_MAX_OS                |                                | (3)  |
| OS_MAX_TASKS             |                                | (3)  |
|                          | OS_CFG_OBJ_TYPE_CHK_EN         |      |
| OS_LOWEST_PRIO           | OS_CFG_PRIO_MAX                |      |
|                          | OS_CFG_SCHED_LOCK_TIME_MEAS_EN |      |
|                          | OS_CFG_SCHED_ROUND_ROBIN_EN    |      |
|                          | OS_CFG_STK_SIZE_MIN            |      |
| OS_FLAG_EN               | OS_CFG_FLAG_EN                 |      |
| OS_FLAG_ACCEPT_EN        |                                | (6)  |
| OS_FLAG_DEL_EN           | OS_CFG_FLAG_DEL_EN             |      |
| OS_FLAG_WAIT_CLR_EN      | OS_CFG_FLAG_MODE_CLR_EN        |      |
| OS_FLAG_NAME_EN          |                                | (2)  |
| OS_FLAG_NBITS            |                                | (4)  |
| OS_FLAG_QUERY_EN         |                                | (5)  |
|                          | OS_CFG_PEND_ABORT_EN           |      |
| OS_MBOX_EN               |                                |      |
| OS_MBOX_ACCEPT_EN        |                                | (6)  |

Appendix C

| <b>μC/OS-II (OS_CFG.H)</b> | <b>μC/OS-III (OS_CFG.H)</b> | <b>Note</b> |
|----------------------------|-----------------------------|-------------|
| OS_MBOX_DEL_EN             |                             |             |
| OS_MBOX_PEND_ABORT_EN      |                             |             |
| OS_MBOX_POST_EN            |                             |             |
| OS_MBOX_POST_OPT_EN        |                             |             |
| OS_MBOX_QUERY_EN           |                             | (5)         |
| OS_MEM_EN                  | OS_CFG_MEM_EN               |             |
| OS_MEM_NAME_EN             |                             | (2)         |
| OS_MEM_QUERY_EN            |                             | (5)         |
| OS_MUTEX_EN                | OS_CFG_MUTEX_EN             |             |
| OS_MUTEX_ACCEPT_EN         |                             | (6)         |
| OS_MUTEX_DEL_EN            | OS_CFG_MUTEX_DEL_EN         |             |
|                            | OS_CFG_MUTEX_PEND_ABORT_EN  |             |
| OS_MUTEX_QUERY_EN          |                             | (5)         |
| OS_Q_EN                    | OS_CFG_Q_EN                 |             |
| OS_Q_ACCEPT_EN             |                             | (6)         |
| OS_Q_DEL_EN                | OS_CFG_Q_DEL_EN             |             |
| OS_Q_FLUSH_EN              | OS_CFG_Q_FLUSH_EN           |             |
|                            | OS_CFG_Q_PEND_ABORT_EN      |             |
| OS_Q_POST_EN               |                             | (7)         |
| OS_Q_POST_FRONT_EN         |                             | (7)         |
| OS_Q_POST_OPT_EN           |                             | (7)         |
| OS_Q_QUERY_EN              |                             | (5)         |
| OS_SCHED_LOCK_EN           |                             |             |
| OS_SEM_EN                  | OS_CFG_SEM_EN               |             |
| OS_SEM_ACCEPT_EN           |                             | (6)         |
| OS_SEM_DEL_EN              | OS_CFG_SEM_DEL_EN           |             |
| OS_SEM_PEND_ABORT_EN       | OS_CFG_SEM_PEND_ABORT_EN    |             |

| $\mu$ C/OS-II (OS_CFG.H) | $\mu$ C/OS-III (OS_CFG.H)     | Note |
|--------------------------|-------------------------------|------|
| OS_SEM_QUERY_EN          |                               | (5)  |
| OS_SEM_SET_EN            | OS_CFG_SEM_SET_EN             |      |
| OS_TASK_STAT_EN          | OS_CFG_STAT_TASK_EN           |      |
| OS_TASK_STK_CHK_EN       | OS_CFG_STAT_TASK_STK_CHK_EN   |      |
| OS_TASK_CHANGE_PRIO_EN   | OS_CFG_TASK_CHANGE_PRIO_EN    |      |
| OS_TASK_CREATE_EN        |                               |      |
| OS_TASK_CREATE_EXT_EN    |                               |      |
| OS_TASK_DEL_EN           | OS_CFG_TASK_DEL_EN            |      |
| OS_TASK_NAME_EN          |                               | (2)  |
|                          | OS_CFG_TASK_Q_EN              |      |
|                          | OS_CFG_TASK_Q_PEND_ABORT_EN   |      |
| OS_TASK_QUERY_EN         |                               | (5)  |
| OS_TASK_PROFILE_EN       | OS_CFG_TASK_PROFILE_EN        |      |
|                          | OS_CFG_TASK_REG_TBL_SIZE      |      |
|                          | OS_CFG_TASK_SEM_PEND_ABORT_EN |      |
| OS_TASK_SUSPEND_EN       | OS_CFG_TASK_SUSPEND_EN        |      |
| OS_TASK_SW_HOOK_EN       |                               |      |
| OS_TICK_STEP_EN          |                               | (8)  |
| OS_TIME_DLY_HMSM_EN      | OS_CFG_TIME_DLY_HMSM_EN       |      |
| OS_TIME_DLY_RESUME_EN    | OS_CFG_TIME_DLY_RESUME_EN     |      |
| OS_TIME_GET_SET_EN       |                               |      |
| OS_TIME_TICK_HOOK_EN     |                               |      |
| OS_TMR_EN                | OS_CFG_TMR_EN                 |      |
| OS_TMR_CFG_NAME_EN       |                               | (2)  |
| OS_TMR_DEL_EN            | OS_CFG_TMR_DEL_EN             |      |

Table C-5  $\mu$ C/OS-III uses “CFG” in configuration

- TC-5(1) **DEBUG** is replaced with **DBG**.
- TC-5(2) In  $\mu\text{C}/\text{OS-II}$ , all kernel objects have ASCII names after creation. In  $\mu\text{C}/\text{OS-III}$ , ASCII names are assigned when the object is created.
- TC-5(3) In  $\mu\text{C}/\text{OS-II}$ , it is necessary to declare the maximum number of kernel objects (number of tasks, number of event flag groups, message queues, etc.) at compile time. In  $\mu\text{C}/\text{OS-III}$ , all kernel objects are allocated at run time so it is no longer necessary to specify the maximum number of these objects. This feature saves valuable RAM as it is no longer necessary to over allocate objects.
- TC-5(4) In  $\mu\text{C}/\text{OS-II}$ , event-flag width must be declared at compile time through **OS\_FLAG\_NBITS**. In  $\mu\text{C}/\text{OS-III}$ , this is accomplished by defining the width (i.e., number of bits) in **OS\_TYPE.H** through the data type **OS\_FLAG**. The default is typically 32 bits.
- TC-5(5)  $\mu\text{C}/\text{OS-III}$  does not provide query services to the application.
- TC-5(6)  $\mu\text{C}/\text{OS-III}$  does not directly provide “**accept**” function calls as with  $\mu\text{C}/\text{OS-II}$ . Instead, **OS???Pend()** functions provide an option that emulates the “**accept**” functionality.
- TC-5(7) In  $\mu\text{C}/\text{OS-II}$ , there are a number of “**post**” functions. The features offered are now combined in the **OS???Post()** functions in  $\mu\text{C}/\text{OS-III}$ .
- TC-5(8) The  $\mu\text{C}/\text{OS-View}$  feature **OS\_TICK\_STEP\_EN** is not present in  $\mu\text{C}/\text{OS-III}$  since  $\mu\text{C}/\text{OS-View}$  is an obsolete product.

### C-3 VARIABLE NAME CHANGES

Some of the variable names in  $\mu$ C/OS-II are changed for  $\mu$ C/OS-III to be more consistent with coding conventions. Significant variables are shown in Table C-6.

| $\mu$ C/OS-II ( $\mu$ COS_II.H) | $\mu$ C/OS-III (OS.H) | Note |
|---------------------------------|-----------------------|------|
| OSTxSwCtr                       | OSTaskCtxSwCtr        |      |
| OSCPUUsage                      | OSStatTaskCPUUsage    | (1)  |
| OSIdleCtr                       | OSIdleTaskCtr         |      |
| OSIdleCtrMax                    | OSIdleTaskCtrMax      |      |
| OSIntNesting                    | OSIntNestingCtr       | (2)  |
| OSPrioCur                       | OSPrioCur             |      |
| OSPrioHighRdy                   | OSPrioHighRdy         |      |
| OSRunning                       | OSRunning             |      |
| OSSchedNesting                  | OSSchedLockNestingCtr | (3)  |
|                                 | OSSchedLockTimeMax    |      |
| OSTaskCtr                       | OSTaskQty             |      |
| OSTCBCur                        | OSTCBCurPtr           | (4)  |
| OSTCBHighRdy                    | OSTCBHighRdyPtr       | (4)  |
| OSTime                          | OSTickCtr             | (5)  |
| OSTmrTime                       | OSTmrTickCtr          |      |

Table C-6 Changes in variable naming

TC-6(1) In  $\mu$ C/OS-II, **OSCPUUsage** contains the total CPU utilization in percentage format. If the CPU is busy 12% of the time, **OSCPUUsage** has the value 12. In  $\mu$ C/OS-III, the same information is provided in **OSStatTaskCPUUsage**.

TC-6(2) In  $\mu$ C/OS-II, **OSIntNesting** keeps track of the number of interrupts nesting.  $\mu$ C/OS-III uses **OSIntNestingCtr**. The “Ctr” has been added to indicate that this variable is a counter.

- TC-6(3) `OSSchedNesting` represents the number of times `OSSchedLock()` is called.  $\mu$ C/OS-III renames this variable to `OSSchedLockNestingCtr` to better represent the variable's meaning.
- TC-6(4) In  $\mu$ C/OS-II, `OSTCBCur` and `OSTCBHighRdy` are pointers to the `OS_TCB` of the current task, and to the `OS_TCB` of the highest-priority task that is ready to run. In  $\mu$ C/OS-III, these are renamed by adding the "Ptr" to indicate that they are pointers.
- TC-6(5) The internal counter of the number of ticks since power up, or the last time the variable was changed through `OSTimeSet()`, has been renamed to better reflect its function.

## C-4 API CHANGES

The most significant change from  $\mu$ C/OS-II to  $\mu$ C/OS-III occurs in the API. In order to port a  $\mu$ C/OS-II-based application to  $\mu$ C/OS-III, it is necessary to change the way services are invoked.

Table C-7 shows changes in the way critical sections in  $\mu$ C/OS-III are handled. Specifically,  $\mu$ C/OS-II defines macros to disable interrupts, and they are moved to  $\mu$ C/CPU since they are CPU specific functions.

| $\mu$ C/OS-II ( <code>OS_CPU.H</code> ) | $\mu$ C/CPU ( <code>CPU.H</code> ) | Note |
|---|------------------------------------|------|
| <code>OS_ENTER_CRITICAL()</code>        | <code>CPU_CRITICAL_ENTER()</code>  |      |
| <code>OS_EXIT_CRITICAL()</code>         | <code>CPU_CRITICAL_EXIT()</code>   |      |

Table C-7 Changes in variable naming

One of the biggest changes in the  $\mu$ C/OS-III API is its consistency. In fact, based on the function performed, it is possible to guess which arguments are needed, and in what order. For example, "`*p_err`" is a pointer to an error-returned variable. When present, "`*p_err`" is always the last argument of a function. In  $\mu$ C/OS-II, error-returned values are at times returned as a "`*perr`," and at other times as the return value of the function.

## C-4-1 EVENT FLAGS

Table C-8 shows the API for event-flag management.

| $\mu\text{C}/\text{OS-II}$ (os_FLAG.C)  | $\mu\text{C}/\text{OS-III}$ (os_FLAG.C)  | Note |
|---|--|------|
| <pre>OS_FLAGS OSFlagAccept(     OS_FLAG_GRP *pgrp,     OS_FLAGS    flags,     INT8U       wait_type,     INT8U       *perr);</pre>                        |  | (1)  |
| <pre>OS_FLAG_GRP * OSFlagCreate(     OS_FLAGS    flags,     INT8U       *perr);</pre>   | <pre>void OSFlagCreate(     OS_FLAG_GRP *p_grp,     CPU_CHAR    *p_name,     OS_FLAGS    flags,     OS_ERR      *p_err);</pre>   | (2)  |
| <pre>OS_FLAG_GRP * OSFlagDel(     OS_FLAG_GRP *pgrp,     INT8U       opt,     INT8U       *perr);</pre>   | <pre>OS_OBJ_QTY OSFlagDel(     OS_FLAG_GRP *p_grp,     OS_OPT      opt,     OS_ERR      *p_err);</pre>   |      |
| <pre>INT8U OSFlagNameGet(     OS_FLAG_GRP *pgrp,     INT8U       **pname,     INT8U       *perr);</pre>   |  |      |
| <pre>void OSFlagNameSet(     OS_FLAG_GRP *pgrp,     INT8U       *pname,     INT8U       *perr);</pre>   |  | (3)  |
| <pre>OS_FLAGS OSFlagPend(     OS_FLAG_GRP *pgrp,     OS_FLAGS    flags,     INT8U       wait_type,     INT32U      timeout,     INT8U       *perr);</pre> | <pre>OS_FLAGS OSFlagPend(     OS_FLAG_GRP *p_grp,     OS_FLAGS    flags,     OS_TICK     timeout,     OS_OPT      opt,     OS_TS       *p_ts,     OS_ERR      *p_err);</pre> |      |

| <b>μC/OS-II (OS_FLAG.C)</b>  | <b>μC/OS-III (OS_FLAG.C)</b>   | <b>Note</b> |
|--|--|-------------|
| <pre>OS_FLAGS OSFlagPendGetFlagsRdy(     void);</pre>  | <pre>OS_FLAGS OSFlagPendGetFlagsRdy(     OS_ERR      *p_err);</pre>  |             |
| <pre>OS_FLAGS OSFlagPost(     OS_FLAG_GRP *pgrp,     OS_FLAGS    flags,     INT8U      opt,     INT8U      *perr);</pre> | <pre>OS_FLAGS OSFlagPost(     OS_FLAG_GRP *p_grp,     OS_FLAGS    flags,     OS_OPT      opt,     OS_ERR      *p_err);</pre> |             |
| <pre>OS_FLAGS OSFlagQuery(     OS_FLAG_GRP *pgrp,     INT8U      *perr);</pre>   |  | (4)         |

Table C-8 Event Flags API

- TC-8(1) In μC/OS-III, there is no “accept” API. This feature is actually built-in the **OSFlagPend()** by specifying the **OS\_OPT\_PEND\_NON\_BLOCKING** option.
- TC-8(2) In μC/OS-II, **OSFlagCreate()** returns the address of an **OS\_FLAG\_GRP**, which is used as the “handle” to the event-flag group. In μC/OS-III, the application must allocate storage for an **OS\_FLAG\_GRP**, which serves the same purpose as the **OS\_EVENT**. The benefit in μC/OS-III is that it is not necessary to predetermine the number of event flags at compile time.
- TC-8(3) In μC/OS-II, the user may assign a name to an event-flag group after the group is created. This functionality is built-into **OSFlagCreate()** for μC/OS-III.
- TC-8(4) μC/OS-III does not provide query services, as they are typically rarely used.



## C-4-2 MESSAGE MAILBOXES

Table C-9 shows the API for message mailbox management. Note that  $\mu$ C/OS-III does not directly provide services for managing message mailboxes. Given that a message mailbox is a message queue of size one,  $\mu$ C/OS-III can easily emulate message mailboxes.

| $\mu$ C/OS-II (os_mbox.c)   | $\mu$ C/OS-III (os_q.c)   | Note |
|---|---|------|
| <pre>void * OSMboxAccept(     OS_EVENT *pevent);</pre>                                    |   | (1)  |
| <pre>OS_EVENT * OSMboxCreate(     void *pmsg);</pre>                                      | <pre>void OSQCreate(     OS_Q *p_q,     CPU_CHAR *p_name,     OS_MSG_QTY max_qty,     OS_ERR *p_err);</pre>                                       | (2)  |
| <pre>void * OSMboxDel(     OS_EVENT *pevent,     INT8U opt,     INT8U *perr);</pre>       | <pre>OS_OBJ_QTY, OSQDel(     OS_Q *p_q,     OS_OPT opt,     OS_ERR *p_err);</pre>   |      |
| <pre>void * OSMboxPend(     OS_EVENT *pevent,     INT32U timeout,     INT8U *perr);</pre> | <pre>void * OSQPend(     OS_Q *p_q,     OS_TICK timeout,     OS_OPT opt,     OS_MSG_SIZE *p_msg_size,     CPU_TS *p_ts,     OS_ERR *p_err);</pre> | (3)  |
| <pre>INT8U OSMBoxPendAbort(     OS_EVENT *pevent,     INT8U opt,     INT8U *perr);</pre>  | <pre>OS_OBJ_QTY OSQPendAbort(     OS_Q *p_q,     OS_OPT opt,     OS_ERR *p_err);</pre>  |      |

| <b>μC/OS-II (OS_MBOX.C)</b>   | <b>μC/OS-III (OS_Q.C)</b>   | <b>Note</b> |
|---|---|-------------|
| <pre> INT8U OSMboxPost(     OS_EVENT *pevent,     void *pmsg); </pre>                   | <pre> void OSQPost(     OS_Q *p_q,     Void *p_void,     OS_MSG_SIZE msg_size,     OS_OPT opt,     OS_ERR *p_err); </pre> | (4)         |
| <pre> INT8U OSMboxPostOpt(     OS_EVENT *pevent,     void *pmsg,     INT8U opt); </pre> |   | (4)         |
| <pre> INT8U OSMboxQuery(     OS_EVENT *pevent,     OS_MBOX_DATA *p_mbox_data); </pre>   |   | (5)         |

Table C-9 **Message Mailbox API**

- TC-9(1) In μC/OS-III, there is no “accept” API since this feature is built into the `OSQPend()` by specifying the `OS_OPT_PEND_NON_BLOCKING` option.
- TC-9(2) In μC/OS-II, `OSMboxCreate()` returns the address of an `OS_EVENT`, which is used as the “handle” to the message mailbox. In μC/OS-III, the application must allocate storage for an `OS_Q`, which serves the same purpose as the `OS_EVENT`. The benefit in μC/OS-III is that it is not necessary to predetermine the number of message queues at compile time.
- TC-9(3) μC/OS-III returns additional information about the message received. Specifically, the sender specifies the size of the message as a snapshot of the current timestamp is taken and stored as part of the message. The receiver of the message therefore knows when the message was sent.
- TC-9(4) In μC/OS-III, `OSQPost()` offers a number of options that replaces the two post functions provided in μC/OS-II.
- TC-9(5) μC/OS-III does not provide query services, as they were rarely used.

### C-4-3 MEMORY MANAGEMENT

Table C-10 shows the difference in API for memory management.

| $\mu$ C/OS-II (OS_MEM.C)  | $\mu$ C/OS-III (OS_MEM.C)  | Note |
|---|--|------|
| <pre>OS_MEM * OSMemCreate(     void      *addr,     INT32U    nblks,     INT32U    blksize,     INT8U     *perr);</pre> | <pre>void OSMemCreate(     OS_MEM    *p_mem,     CPU_CHAR  *p_name,     void      *p_addr,     OS_MEM_QTY n_blks,     OS_MEM_SIZE blk_size,     OS_ERR    *p_err);</pre> | (1)  |
| <pre>void * OSMemGet(     OS_MEM    *pmem,     INT8U     *perr);</pre>  | <pre>void * OSMemGet(     OS_MEM    *p_mem,     OS_ERR    *p_err);</pre>   |      |
| <pre>INT8U OSMemNameGet(     OS_MEM    *pmem,     INT8U     **pname,     INT8U     *perr);</pre>                        |  |      |
| <pre>void OSMemNameSet(     OS_MEM    *pmem,     INT8U     *pname,     INT8U     *perr);</pre>                          | <pre>void OSMemPut(     OS_MEM    *p_mem,     void      *p_blk,     OS_ERR    *p_err);</pre>   | (2)  |
| <pre>INT8U OSMemPut(     OS_MEM    *pmem,     void      *pblk);</pre>   |  | (3)  |
| <pre>INT8U OSMemQuery(     OS_MEM    *pmem,     OS_MEM_DATA *p_mem_data);</pre>   |  |      |

Table C-10 Memory Management API

TC-10(1) In  $\mu$ C/OS-II, `OSMemCreate()` returns the address of an `OS_MEM` object, which is used as the “handle” to the newly created memory partition. In  $\mu$ C/OS-III, the application must allocate storage for an `OS_MEM`, which serves the same purpose. The benefit in  $\mu$ C/OS-III is that it is not necessary to predetermine the number of memory partitions at compile time.

TC-10(2)  $\mu$ C/OS-III does not need an `OSMemNameSet()` since the name of the memory partition is passed as an argument to `OSMemCreate()`.

TC-10(3)  $\mu$ C/OS-III does not support query calls.

### C-4-4 MUTUAL EXCLUSION SEMAPHORES

Table C-11 shows the difference in API for mutual exclusion semaphore management.

| $\mu$ C/OS-II (OS_MUTEX.C)  | $\mu$ C/OS-III (OS_MUTEX.C)  | Note |
|---|--|------|
| <pre> BOOLEAN OSMutexAccept(     OS_EVENT    *pevent,     INT8U       *perr);         </pre>                      |  | (1)  |
| <pre> OS_EVENT * OSMutexCreate(     INT8U       prio,     INT8U       *perr);         </pre>                      | <pre> void OSMutexCreate(     OS_MUTEX    *p_mutex,     CPU_CHAR    *p_name,     OS_ERR      *p_err);         </pre>   | (2)  |
| <pre> OS_EVENT * OSMutexDel(     OS_EVENT    *pevent,     INT8U       opt,     INT8U       *perr);         </pre> | <pre> void OSMutexDel(     OS_MUTEX    *p_mutex,     OS_OPT      opt,     OS_ERR      *p_err);         </pre>  |      |
| <pre> void OSMutexPend(     OS_EVENT    *pevent,     INT32U      timeout,     INT8U       *perr);         </pre>  | <pre> void OSMutexPend(     OS_MUTEX    *p_mutex,     OS_TICK     timeout,     OS_OPT      opt,     CPU_TS      *p_ts,     OS_ERR      *p_err);         </pre> | (3)  |
|   | <pre> OS_OBJ_QTY OSMutexPendAbort(     OS_MUTEX    *p_mutex,     OS_OPT      opt,     OS_ERR      *p_err);         </pre>                                      |      |

| $\mu$ C/OS-II (OS_MUTEX.C)  | $\mu$ C/OS-III (OS_MUTEX.C)  | Note |
|---|--|------|
| <pre> INT8U OSMutexPost(     OS_EVENT    *pevent);         </pre>                                   | <pre> void OSMutexPost(     OS_MUTEX    *p_mutex,     OS_OPT       opt,     OS_ERR       *p_err);         </pre> |      |
| <pre> INT8U OSMutexQuery(     OS_EVENT    *pevent,     OS_MUTEX_DATA *p_mutex_data);         </pre> |  |      |

Table C-11 Mutual Exclusion Semaphore Management API

- TC-11(1) In  $\mu$ C/OS-III, there is no “accept” API, since this feature is built into the `OSMutexPend()` by specifying the `OS_OPT_PEND_NON_BLOCKING` option.
- TC-11(2) In  $\mu$ C/OS-II, `OSMutexCreate()` returns the address of an `OS_EVENT`, which is used as the “handle” to the message mailbox. In  $\mu$ C/OS-III, the application must allocate storage for an `OS_MUTEX`, which serves the same purpose as the `OS_EVENT`. The benefit in  $\mu$ C/OS-III is that it is not necessary to predetermine the number of mutual-exclusion semaphores at compile time.
- TC-11(3)  $\mu$ C/OS-III returns additional information when a mutex is released. The releaser takes a snapshot of the current time stamp and stores it in the `OS_MUTEX`. The new owner of the mutex therefore knows when the mutex was released.
- TC-11(4)  $\mu$ C/OS-III does not provide query services as they were rarely used.

## C-4-5 MESSAGE QUEUES

Table C-12 shows the difference in API for message-queue management.

| <b>μC/OS-II (os_q.c)</b>   | <b>μC/OS-III (os_q.c)</b>   | <b>Note</b> |
|--|---|-------------|
| <pre>void * OSQAccept(     OS_EVENT *pevent,     INT8U *perr);</pre>                   |   | (1)         |
| <pre>OS_EVENT * OSQCreate(     void **start,     INT16U size);</pre>                   | <pre>void OSQCreate(     OS_Q *p_q,     CPU_CHAR *p_name,     OS_MSG_QTY max_qty,     OS_ERR *p_err);</pre>                                       | (2)         |
| <pre>OS_EVENT * OSQDel(     OS_EVENT *pevent,     INT8U opt,     INT8U *perr);</pre>   | <pre>OS_OBJ_QTY, OSQDel(     OS_Q *p_q,     OS_OPT opt,     OS_ERR *p_err);</pre>   |             |
| <pre>INT8U OSQFlush(     OS_EVENT *pevent);</pre>                                      | <pre>OS_MSG_QTY OSQFlush(     OS_Q *p_q,     OS_ERR *p_err);</pre>  |             |
| <pre>void * OSQPend(     OS_EVENT *pevent,     INT32U timeout,     INT8U *perr);</pre> | <pre>void * OSQPend(     OS_Q *p_q,     OS_MSG_SIZE *p_msg_size,     OS_TICK timeout,     OS_OPT opt,     CPU_TS *p_ts,     OS_ERR *p_err);</pre> | (3)         |
| <pre>INT8U OSQPendAbort(     OS_EVENT *pevent,     INT8U opt,     INT8U *perr);</pre>  | <pre>OS_OBJ_QTY OSQPendAbort(     OS_Q *p_q,     OS_OPT opt,     OS_ERR *p_err);</pre>  |             |
| <pre>INT8U OSQPost(     OS_EVENT *pevent,     void *pmsg);</pre>                       | <pre>void OSQPost(     OS_Q *p_q,     void *p_void,     OS_MSG_SIZE msg_size,     OS_OPT opt,     OS_ERR *p_err);</pre>                           | (4)         |

| $\mu$ C/OS-II (os_q.c)   | $\mu$ C/OS-III (os_q.c) | Note |
|--|-------------------------|------|
| <pre> INT8U OSQPostFront(     OS_EVENT *pevent,     void      *pmsg); </pre>                 |                         |      |
| <pre> INT8U OSQPostOpt(     OS_EVENT *pevent,     void      *pmsg,     INT8U    opt); </pre> |                         | (4)  |
| <pre> INT8U OSQQuery(     OS_EVENT *pevent,     OS_Q_DATA *p_q_data); </pre>                 |                         | (5)  |

Table C-12 Message Queue Management API

- TC-12(1) In  $\mu$ C/OS-III, there is no “accept” API as this feature is built into the `OSQPend()` by specifying the `OS_OPT_PEND_NON_BLOCKING` option.
- TC-12(2) In  $\mu$ C/OS-II, `OSQCreate()` returns the address of an `OS_EVENT`, which is used as the “handle” to the message queue. In  $\mu$ C/OS-III, the application must allocate storage for an `OS_Q` object, which serves the same purpose as the `OS_EVENT`. The benefit in  $\mu$ C/OS-III is that it is not necessary to predetermine at compile time, the number of message queues.
- TC-12(3)  $\mu$ C/OS-III returns additional information when a message queue is posted. Specifically, the sender includes the size of the message and takes a snapshot of the current timestamp and stores it in the message. The receiver of the message therefore knows when the message was posted.
- TC-12(4) In  $\mu$ C/OS-III, `OSQPost()` offers a number of options that replaces the three post functions provided in  $\mu$ C/OS-II.
- TC-12(5)  $\mu$ C/OS-III does not provide query services as they were rarely used.

## C-4-6 SEMAPHORES

Table C-13 shows the difference in API for semaphore management.

| <b>μC/OS-II (os_sem.c)</b>  | <b>μC/OS-III (os_sem.c)</b>  | <b>Note</b> |
|---|--|-------------|
| <pre>INT16U OSSemAccept(     OS_EVENT *pevent);</pre>                                   |  | (1)         |
| <pre>OS_EVENT * OSSemCreate(     INT16U cnt);</pre>                                     | <pre>void OSSemCreate(     OS_SEM *p_sem,     CPU_CHAR *p_name,     OS_SEM_CTR cnt,     OS_ERR *p_err);</pre>                  | (2)         |
| <pre>OS_EVENT * OSSemDel(     OS_EVENT *pevent,     INT8U opt,     INT8U *perr);</pre>  | <pre>OS_OBJ_QTY, OSSemDel(     OS_SEM *p_sem,     OS_OPT opt,     OS_ERR *p_err);</pre>  |             |
| <pre>void OSSemPend(     OS_EVENT *pevent,     INT32U timeout,     INT8U *perr);</pre>  | <pre>OS_SEM_CTR OSSemPend(     OS_SEM *p_sem,     OS_TICK timeout,     OS_OPT opt,     CPU_TS *p_ts,     OS_ERR *p_err);</pre> | (3)         |
| <pre>INT8U OSSemPendAbort(     OS_EVENT *pevent,     INT8U opt,     INT8U *perr);</pre> | <pre>OS_OBJ_QTY OSSemPendAbort(     OS_SEM *p_sem,     OS_OPT opt,     OS_ERR *p_err);</pre>                                   |             |
| <pre>void OSSemPost(     OS_EVENT *pevent);</pre>                                       | <pre>void OSSemPost(     OS_SEM *p_sem,     OS_OPT opt,     OS_ERR *p_err);</pre>  |             |
| <pre>INT8U OSSemQuery(     OS_EVENT *pevent,     OS_SEM_DATA *p_sem_data);</pre>        |  | (4)         |



| $\mu$ C/OS-II (os_sem.c)  | $\mu$ C/OS-III (os_sem.c)  | Note |
|---|--|------|
| <pre>void OSSemSet(     OS_EVENT *pevent,     INT16U cnt,     INT8U *perr);</pre> | <pre>void OSSemSet(     OS_SEM *p_sem,     OS_SEM_CTR cnt,     OS_ERR *p_err);</pre> |      |

Table C-13 Semaphore Management API

- TC-13(1) In  $\mu$ C/OS-III, there is no “accept” API since this feature is built into the `OSSemPend()` by specifying the `OS_OPT_PEND_NON_BLOCKING` option.
- TC-13(2) In  $\mu$ C/OS-II, `OSSemCreate()` returns the address of an `OS_EVENT`, which is used as the “handle” to the semaphore. In  $\mu$ C/OS-III, the application must allocate storage for an `OS_SEM` object, which serves the same purpose as the `OS_EVENT`. The benefit in  $\mu$ C/OS-III is that it is not necessary to predetermine the number of semaphores at compile time.
- TC-13(3)  $\mu$ C/OS-III returns additional information when a semaphore is signaled. The ISR or task that signals the semaphore takes a snapshot of the current timestamp and stores this in the `OS_SEM` object signaled. The receiver of the signal therefore knows when the signal was sent.
- TC-13(4)  $\mu$ C/OS-III does not provide query services, as they were rarely used.

## C-4-7 TASK MANAGEMENT

Table C-14 shows the difference in API for task-management services.

| <b>μC/OS-II (os_TASK.C)</b>  | <b>μC/OS-III (os_TASK.C)</b>  | <b>Note</b> |
|--|---|-------------|
| <pre> INT8U OSTaskChangePrio(     INT8U    oldprio,     INT8U    newprio);         </pre>  | <pre> void OSTaskChangePrio(     OS_TCB   *p_tcb,     OS_PRIO  prio,     OS_ERR   *p_err);         </pre>   | (1)         |
| <pre> INT8U OSTaskCreate(     void      (*task)(void *p_arg),     void      *p_arg,     OS_STK    *ptos,     INT8U     prio);         </pre>   | <pre> void OSTaskCreate(     OS_TCB   *p_tcb,     CPU_CHAR *p_name,     OS_TASK_PTR *p_task,     void      *p_arg,     OS_PRIO  prio,     CPU_STK   *p_stk_base,     CPU_STK_SIZE stk_limit,     CPU_STK_SIZE stk_size,     OS_MSG_QTY q_size,     OS_TICK    time_quanta,     void      *p_ext,     OS_OPT     opt,     OS_ERR     *p_err);         </pre> | (2)         |
| <pre> INT8U OSTaskCreateExt(     void      (*task)(void *p_arg),     void      *p_arg,     OS_STK    *ptos,     INT8U     prio,     INT16U    id,     OS_STK    *pbos,     INT32U    stk_size,     void      *pext,     INT16U    opt);         </pre> | <pre> void OSTaskCreate(     OS_TCB   *p_tcb,     CPU_CHAR *p_name,     OS_TASK_PTR *p_task,     void      *p_arg,     OS_PRIO  prio,     CPU_STK   *p_stk_base,     CPU_STK_SIZE stk_limit,     CPU_STK_SIZE stk_size,     OS_MSG_QTY q_size,     OS_TICK    time_quanta,     void      *p_ext,     OS_OPT     opt,     OS_ERR     *p_err);         </pre> | (2)         |
| <pre> INT8U OSTaskDel(     INT8U    prio);         </pre>  | <pre> void OSTaskDel(     OS_TCB   *p_tcb,     OS_ERR   *p_err);         </pre>   |             |

| $\mu$ C/OS-II (os_TASK.C)   | $\mu$ C/OS-III (os_TASK.C)   | Note |
|---|--|------|
| <pre> INT8U OSTaskDelReq(     INT8U    prio); </pre>  |  |      |
| <pre> INT8U OSTaskNameGet(     INT8U    prio,     INT8U    **pname,     INT8U    *perr); </pre> |  |      |
| <pre> void OSTaskNameSet(     INT8U    prio,     INT8U    *pname,     INT8U    *perr); </pre>   |  | (3)  |
|   | <pre> OS_MSG_QTY OSTaskQFlush(     OS_TCB    *p_tcb,     OS_ERR    *p_err); </pre>   | (4)  |
|   | <pre> void * OSTaskQPend(     OS_TICK    timeout,     OS_OPT    opt,     OS_MSG_SIZE *p_msg_size,     CPU_TS    *p_ts,     OS_ERR    *p_err); </pre> | (4)  |
|   | <pre> CPU_BOOLEAN OSTaskQPendAbort(     OS_TCB    *p_tcb,     OS_OPT    opt,     OS_ERR    *p_err); </pre>   | (4)  |
|   | <pre> void OSTaskQPost(     OS_TCB    *p_tcb,     void      *p_void,     OS_MSG_SIZE msg_size,     OS_OPT    opt,     OS_ERR    *p_err); </pre>      | (4)  |
| <pre> INT32U OSTaskRegGet(     INT8U    prio,     INT8U    id,     INT8U    *perr); </pre>      | <pre> OS_REG OSTaskRegGet(     OS_TCB    *p_tcb,     OS_REG_ID id,     OS_ERR    *p_err); </pre>   |      |

Appendix C

| <b>μC/OS-II (os_TASK.C)</b>  | <b>μC/OS-III (os_TASK.C)</b>   | <b>Note</b> |
|--|--|-------------|
| <pre>void OSTaskRegSet(     INT8U    prio,     INT8U    id,     INT32U   value,     INT8U    *perr);</pre> | <pre>void OSTaskRegGet(     OS_TCB   *p_tcb,     OS_REG_ID id,     OS_REG   value,     OS_ERR   *p_err);</pre>             |             |
| <pre>INT8U OSTaskResume(     INT8U    prio);</pre>   | <pre>void OSTaskResume(     OS_TCB   *p_tcb,     OS_ERR   *p_err);</pre>   |             |
|  | <pre>OS_SEM_CTR OSTaskSemPend(     OS_TICK   timeout,     OS_OPT    opt,     CPU_TS    *p_ts,     OS_ERR    *p_err);</pre> | (5)         |
|  | <pre>CPU_BOOLEAN OSTaskSemPendAbort(     OS_TCB    *p_tcb,     OS_OPT    opt,     OS_ERR    *p_err);</pre>                 | (5)         |
|  | <pre>CPU_BOOLEAN OSTaskSemPendAbort(     OS_TCB    *p_tcb,     OS_OPT    opt,     OS_ERR    *p_err);</pre>                 | (5)         |
|  | <pre>OS_SEM_CTR OSTaskSemPost(     OS_TCB    *p_tcb,     OS_OPT    opt,     OS_ERR    *p_err);</pre>                       | (5)         |
|  | <pre>OS_SEM_CTR OSTaskSemSet(     OS_TCB    *p_tcb,     OS_SEM_CTR cnt,     OS_ERR    *p_err);</pre>                       | (5)         |
| <pre>INT8U OSTaskSuspend(     INT8U    prio);</pre>  | <pre>void OSTaskSuspend(     OS_TCB    *p_tcb,     OS_ERR    *p_err);</pre>  |             |

| $\mu$ C/OS-II (os_TASK.C)   | $\mu$ C/OS-III (os_TASK.C)   | Note |
|---|--|------|
| <pre> INT8U OSTaskStkChk(     INT8U    prio,     OS_STK_DATA *p_stk_data);         </pre> | <pre> void OSTaskStkChk(     OS_TCB    *p_tcb,     CPU_STK_SIZE *p_free,     CPU_STK_SIZE *p_used,     OS_ERR    *p_err);         </pre> | (6)  |
|   | <pre> void OSTaskTimeQuantaSet(     OS_TCB    *p_tcb,     OS_TICK    time_quanta,     OS_ERR    *p_err);         </pre>                  | (7)  |
| <pre> INT8U OSTaskQuery(     INT8U    prio,     OS_TCB    *p_task_data);         </pre>   |  | (8)  |

Table C-14 Task Management API

- TC-14(1) In  $\mu$ C/OS-II, each task must have a unique priority. The priority of a task can be changed at run-time, however it can only be changed to an unused priority. This is generally not a problem since  $\mu$ C/OS-II supports up to 255 different priority levels and is rare for an application to require all levels. Since  $\mu$ C/OS-III supports an unlimited number of tasks at each priority, the user can change the priority of a task to any available level.
- TC-14(2)  $\mu$ C/OS-II provides two functions to create a task: `OSTaskCreate()` and `OSTaskCreateExt()`. `OSTaskCreateExt()` is recommended since it offers more flexibility. In  $\mu$ C/OS-III, only one API is used to create a task, `OSTaskCreate()`, which offers similar features to `OSTaskCreateExt()` and provides additional ones.
- TC-14(3)  $\mu$ C/OS-III does not need an `OSTaskNameSet()` since an ASCII name for the task is passed as an argument to `OSTaskCreate()`.
- TC-14(4)  $\mu$ C/OS-III allows tasks or ISRs to send messages directly to a task instead of having to pass through a mailbox or a message queue as does  $\mu$ C/OS-II.
- TC-14(5)  $\mu$ C/OS-III allows tasks or ISRs to directly signal a task instead of having to pass through a semaphore as does  $\mu$ C/OS-II.

- TC-14(6) In  $\mu$ C/OS-II, the user must allocate storage for a special data structure called `OS_STK_DATA`, which is used to place the result of a stack check of a task. This data structure contains only two fields: `.OSFree` and `.OSUsed`. In  $\mu$ C/OS-III, it is required that the caller pass pointers to destination variables where those values will be placed.
- TC-14(7)  $\mu$ C/OS-III allows users to specify the time quanta of each task on a per-task basis. This is available since  $\mu$ C/OS-III supports multiple tasks at the same priority, and allows for round robin scheduling. The time quanta for a task is specified when the task is created, but it can be changed by the API at run time.
- TC-14(8)  $\mu$ C/OS-III does not provide query services as they were rarely used.

## C-4-8 TIME MANAGEMENT

Table C-15 shows the difference in API for time-management services.

| $\mu$ C/OS-II (os_TIME.C)  | $\mu$ C/OS-III (os_TIME.C)   | Note |
|--|--|------|
| <pre>void OSTimeDly(     INT32U    ticks);</pre>   | <pre>void OSTimeDly(     OS_TICK    dly,     OS_OPT    opt,     OS_ERR    *p_err);</pre>   | (1)  |
| <pre>INT8U OSTimeDlyHMSM(     INT8U    hours,     INT8U    minutes,     INT8U    seconds,     INT16U    ms);</pre> | <pre>void OSTimeDlyHMSM(     CPU_INT16U    hours,     CPU_INT16U    minutes,     CPU_INT16U    seconds,     CPU_INT32U    milli,     OS_OPT    opt,     OS_ERR    *p_err);</pre> | (2)  |
| <pre>INT8U OSTimeDlyResume(     INT8U    prio);</pre>  | <pre>void OSTimeDlyResume(     OS_TCB    *p_tcb,     OS_ERR    *p_err);</pre>  |      |
| <pre>INT32U OSTimeGet(void);</pre>   | <pre>OS_TICK OSTimeGet(     OS_ERR    *p_err);</pre>   |      |

| $\mu$ C/OS-II (os_TIME.C)                        | $\mu$ C/OS-III (os_TIME.C)  | Note |
|--|---|------|
| <pre>void OSTimeSet(     INT32U    ticks);</pre> | <pre>void OSTimeSet(     OS_TICK    ticks,     OS_ERR    *p_err);</pre> |      |
| <pre>void OSTimeTick(void)</pre>                 | <pre>void OSTimeTick(void)</pre>  |      |

Table C-15 Time Management API

TC-15(1)  $\mu$ C/OS-III includes an option argument, which allows the user to delay a task for a certain number of ticks, or wait until the tick counter reaches a certain value. In  $\mu$ C/OS-II, only the former is available.

TC-15(2) `OSTimeDlyHMSM()` in  $\mu$ C/OS-III is more flexible as it allows a user to specify whether to be “strict” about the ranges of hours (0 to 999), minutes (0 to 59), seconds (0 to 59), and milliseconds (0 to 999), or whether to allow any values such as 200 minutes, 75 seconds, or 20,000 milliseconds.

## C-4-9 TIMER MANAGEMENT

Table C-16 shows the difference in API for timer-management services. The timer management in  $\mu$ C/OS-III is similar to that of  $\mu$ C/OS-II except for minor changes in arguments in `OSTmrCreate()`.

| $\mu$ C/OS-II (OS_TMR.C)   | $\mu$ C/OS-III (OS_TMR.C)  | Note |
|--|--|------|
| <pre>OS_TMR * OSTmrCreate(     INT32U    dly,     INT32U    period,     INT8U     opt,     OS_TMR_CALLBACK    callback,     void      *callback_arg,     INT8U     *pname,     INT8U     *perr);</pre> | <pre>void OSTmrCreate(     OS_TMR    *p_tmr,     CPU_CHAR    *p_name,     OS_TICK    dly,     OS_TICK    period,     OS_OPT     opt,     OS_TMR_CALLBACK_PTR    *p_callback,     void      *p_callback_arg,     OS_ERR    *p_err);</pre> |      |

| <b>μC/OS-II (OS_TMR.C)</b>   | <b>μC/OS-III (OS_TMR.C)</b>  | <b>Note</b> |
|--|--|-------------|
| BOOLEAN<br>OSTmrDel(<br>OS_TMR       *ptmr,<br>INT8U       *perr);   | CPU_BOOLEAN<br>OSTmrDel(<br>OS_TMR       *p_tmr,<br>OS_ERR       *p_err);  |             |
| INT8U<br>OSTmrNameGet(<br>OS_TMR       *ptmr,<br>INT8U       **pdest,<br>INT8U       *perr);                         |  |             |
| INT32U<br>OSTmrRemainGet(<br>OS_TMR       *ptmr,<br>INT8U       *perr);  | OS_TICK<br>OSTmrRemainGet(<br>OS_TMR       *p_tmr,<br>OS_ERR       *p_err);  |             |
| INT8U<br>OSTmrStateGet(<br>OS_TMR       *ptmr,<br>INT8U       *perr);  | OS_STATE<br>OSTmrStateGet(<br>OS_TMR       *p_tmr,<br>OS_ERR       *p_err);  |             |
| BOOLEAN<br>OSTmrStart(<br>OS_TMR       *ptmr,<br>INT8U       *perr);   | CPU_BOOLEAN<br>OSTmrStart(<br>OS_TMR       *p_tmr,<br>OS_ERR       *p_err);  |             |
| BOOLEAN<br>OSTmrStop(<br>OS_TMR       *ptmr,<br>INT8U       opt,<br>void       *callback_arg,<br>INT8U       *perr); | CPU_BOOLEAN<br>OSTmrStop(<br>OS_TMR       *p_tmr,<br>OS_OPT       opt,<br>void       *p_callback_arg,<br>OS_ERR       *p_err); |             |
| INT8U<br>OSTmrSignal(void);  |  |             |

Table C-16 Timer Management API



## C-4-10 MISCELLANEOUS

Table C-17 shows the difference in API for miscellaneous services.

| $\mu$ C/OS-II (os_core.c)   | $\mu$ C/OS-III (os_core.c)   | Note |
|---|--|------|
| <pre>INT8U OSEventNameGet(     OS_EVENT *pevent,     INT8U    **pname,     INT8U    *perr);</pre>   |  |      |
| <pre>void OSEventNameSet(     OS_EVENT *pevent,     INT8U    *pname,     INT8U    *perr);</pre>   |  | (1)  |
| <pre>INT16U OSEventPendMulti(     OS_EVENT **pevent_pend,     OS_EVENT **pevent_rdy,     void     **pmsgs_rdy,     INT32U   timeout,     INT8U    *perr);</pre> | <pre>OS_OBJ_QTY OSPendMulti(     OS_PEND_DATA *p_pend_data_tbl,     OS_OBJ_QTY   tbl_size,     OS_TICK      timeout,     OS_OPT       opt,     OS_ERR       *p_err);</pre> | (2)  |
| <pre>void OSInit(void)</pre>  | <pre>void OSInit(     OS_ERR *p_err);</pre>  | (3)  |
| <pre>void OSIntEnter(void)</pre>  | <pre>void OSIntEnter(void);</pre>  |      |
| <pre>void OSIntExit(void)</pre>   | <pre>void OSIntExit(void)</pre>  |      |
|   | <pre>void OSSched(void);</pre>   |      |
| <pre>void OSSchedLock(void)</pre>   | <pre>void OSSchedLock(     OS_ERR *p_err);</pre>   | (4)  |
|   | <pre>void OSSchedRoundRobinCfg(     CPU_BOOLEAN en,     OS_TICK     dflt_time_quanta,     OS_ERR      *p_err);</pre>   | (5)  |
|   | <pre>void OSSchedRoundRobinYield(     OS_ERR *p_err);</pre>  | (6)  |

| <b>μC/OS-II (OS_CORE.C)</b> | <b>μC/OS-III (OS_CORE.C)</b>                       | <b>Note</b> |
|-----------------------------|--|-------------|
| void<br>OSSchedUnlock(void) | void<br>OSSchedUnlock(<br>OS_ERR *p_err);          | (7)         |
| void<br>OSStart(void)       | void<br>OSStart(void);                             |             |
| void<br>OSStatInit(void)    | void<br>OSStatTaskCPUUsageInit(<br>OS_ERR *p_err); | (8)         |
| INT16U<br>OSVersion(void)   | CPU_INT16U<br>OSVersion(<br>OS_ERR *p_err);        | (9)         |

Table C-17 **Miscellaneous API**

- TC-17(1) Objects in μC/OS-III are named when they are created and these functions are not required in μC/OS-III.
- TC-17(2) The implementation of the multi-pend functionality is changed from μC/OS-II. However, the purpose of multi-pend is the same, to allow a task to pend (or wait) on multiple objects. In μC/OS-III, however, it is possible to only multi-pend on semaphores and message queues and not event flags and mutexes.
- TC-17(3) An error code is returned in μC/OS-III for this function. Initialization is successful if **OS\_ERR\_NONE** is received back from **OSInit()**. In μC/OS-II, there is no way of knowing whether there is an error in the configuration that caused **OSInit()** to fail.
- TC-17(4) An error code is returned in μC/OS-III for this function.
- TC-17(5) Enable or disable μC/OS-III's round-robin scheduling at run time, as well as change the default time quanta.
- TC-17(6) A task that completes its work before its time quanta expires may yield the CPU to another task at the same priority.
- TC-17(7) An error code is returned in μC/OS-III for this function.

TC-17(8) Note the change in name for the function that computes the “capacity” of the CPU for the purpose of computing CPU usage at run-time.

TC-17(9) An error code is returned in  $\mu\text{C}/\text{OS-III}$  for this function.

## C-4-11 HOOKS AND PORT

Table C-18 shows the difference in APIs used to port  $\mu\text{C}/\text{OS-II}$  to  $\mu\text{C}/\text{OS-III}$ .

| $\mu\text{C}/\text{OS-II}$ (OS_CPU*.C/H)  | $\mu\text{C}/\text{OS-III}$ (OS_CPU*.C/H)   | Note |
|---|---|------|
|   | OS_TS<br>OSGetTS(void);   | (1)  |
| void<br>OSInitHookBegin(void);  | void<br>OSInitHook(void);   |      |
| void<br>OSInitHookEnd(void);  |   |      |
| void<br>OSTaskCreateHook(<br>OS_TCB *ptcb);   | void<br>OSTaskCreateHook(<br>OS_TCB *p_tcb);  |      |
| void<br>OSTaskDelHook(<br>OS_TCB *ptcb);  | void<br>OSTaskDelHook(<br>OS_TCB *p_tcb);   |      |
| void<br>OSTaskIdleHook(void);   | void<br>OSIdleTaskHook(void);   |      |
|   | void<br>OSTaskReturnHook(<br>OS_TCB *p_tcb);  | (2)  |
| void<br>OSTaskStatHook(void)  | void<br>OSStatTaskHook(void);   |      |
| void<br>OSTaskStkInit(<br>void (*task)(void *p_arg),<br>void *p_arg,<br>OS_STK *ptos,<br>INT16U opt); | CPU_STK *<br>OSTaskStkInit(<br>OS_TASK_PTR p_task,<br>void *p_arg,<br>CPU_STK *p_stk_base,<br>CPU_STK *p_stk_limit,<br>CPU_STK_SIZE size,<br>OS_OPT opt); | (3)  |
| void<br>OSTaskSwHook(void)  | void<br>OSTaskSwHook(void);   |      |

| <b>μC/OS-II (OS_CPU*.C/H)</b>            | <b>μC/OS-III (OS_CPU*.C/H)</b> | <b>Note</b> |
|--|--------------------------------|-------------|
| void<br>OSTCBInitHook(<br>OS_TCB *ptcb); |                                | (4)         |
| void<br>OSTimeTickHook(void);            | void<br>OSTimeTickHook(void);  |             |
| void<br>OSStartHighRdy(void);            | void<br>OSStartHighRdy(void);  | (5)         |
| void<br>OSIntCtxSw(void);                | void<br>OSIntCtxSw(void);      | (5)         |
| void<br>OSCtxSw(void);                   | void<br>OSCtxSw(void);         | (5)         |

Table C-18 Hooks and Port API

- TC-18(1) μC/OS-III requires that the Board Support Package (BSP) provide a 32-bit free-running counter (from 0x00000000 to 0xFFFFFFFF and rolls back to 0x00000000) for the purpose of performing time measurements. When a signal is sent, or a message is posted, this counter is read and sent to the recipient. This allows the recipient to know when the message was sent. If a 32-bit free-running counter is not available, simulate one using a 16-bit counter.
- TC-18(2) μC/OS-III is able to terminate a task that returns. Recall that tasks should not return since they should be either implemented as an infinite loop, or deleted if implemented as run once.
- TC-18(3) The code for `OSTaskStkInit()` must be changed slightly in μC/OS-III since several arguments passed to this function are different than in μC/OS-II. Instead of passing the top-of-stack as in μC/OS-II, `OSTaskStkInit()` is passed the base address of the task stack, as well as the size of the stack.
- TC-18(4) This function is not needed in μC/OS-III.
- TC-18(5) These functions are a part of `OS_CPU_A.ASM`, and should only require name changes for the following variables:

| <b><math>\mu\text{C}/\text{OS-II}</math> variable changes to ...</b> | <b>... in <math>\mu\text{C}/\text{OS-III}</math></b> |
|--|--|
| OSIntNesting   | OSIntNestingCtr                                      |
| OSTCBCur   | OSTCBCurPtr  |
| OSTCBHighRdy   | OSTCBHighRdyPtr                                      |



# D

## MISRA-C:2004 and $\mu$ C/OS-III

MISRA C is a software development standard for the C programming language developed by the Motor Industry Software Reliability Association (MISRA). Its aims are to facilitate code safety, portability, and reliability in the context of embedded systems, specifically those systems programmed in ANSI C. There is also a set of guidelines for MISRA C++.

There are now more MISRA users outside of the automotive industry than within it. MISRA has evolved into a widely accepted model of best practices by leading developers in such sectors as aerospace, telecom, medical devices, defense, railway, and others.

The first edition of the MISRA C standard, "Guidelines for the use of the C language in vehicle based software," was produced in 1998 and is officially known as MISRA-C:1998. MISRA-C:1998 had 127 rules, of which 93 were required and 34 advisory. The rules were numbered in sequence from 1 to 127.

In 2004, a second edition "Guidelines for the use of the C language in critical systems," or MISRA-C:2004 was produced with many substantial changes, including a complete renumbering of the rules.

The MISRA-C:2004 document contains 141 rules, of which 121 are "required" and 20 are "advisory," divided into 21 topical categories, from "Environment" to "Run-time failures."

$\mu$ C/OS-III follows most of the MISRA-C:2004 except that five (5) of the required rules were suppressed. The reasoning behind this is discussed within this appendix.

IAR Embedded Workbench for ARM (EWARM) V5.40 was used to verify MISRA-C:2004 compliance, which required suppressing the rules to achieve a clean build.

## D-1 MISRA-C:2004, RULE 8.5 (REQUIRED)

### Rule Description

There shall be no definitions of objects or functions in a header file.

### Offending code appears as

```
OS_EXT OS_IDLE_CTR OSIdleTaskCtr;
```

OS\_EXT allows us to declare “extern” and storage using a single declaration in OS.H but allocation of storage actually occurs in OS\_VAR.C.

### Rule suppressed

The method used in  $\mu$ C/OS-III is an improved scheme as it avoids declaring variables in multiple files. Storage for a variable must be declared in one file (such as OS\_VAR.C) and another file needs to extern the variables in a separate file (such as OS.H).

### Occurs in

OS.H

## D-2 MISRA-C:2004, RULE 8.12 (REQUIRED)

### Rule Description:

When an array is declared with external linkage, its size shall be stated explicitly or defined implicitly by initialization.

### Offending code appears as

```
extern CPU_STK OSCfg_IdleTaskStk[ ];
```

$\mu$ C/OS-III can be provided in object form (linkable object), but requires that the value and size of known variables and arrays be declared in application code. It is not possible to know the size of the arrays.



**Rule suppressed**

There is no choice other than to suppress or add a fictitious size, which would not be proper. For example, we could specify a size of 1 and the MISRA-C:2004 would pass.

**Occurs in:**

OS.H

**D-3 MISRA-C:2004, RULE 14.7 (REQUIRED)****Rule Description**

A function shall have a single point of exit at the end of the function.

**Offending code appears as**

```
if (argument is invalid) {
    Set error code;
    return;
}
```

**Rule suppressed**

We prefer to exit immediately upon finding an invalid argument rather than create nested “if” statements.

**Occurs in**

OS\_CORE.C  
OS\_FLAG.C  
OS\_INT.C  
OS\_MEM.C  
OS\_MSG.C  
OS\_MUTEX.C  
OS\_PEND\_MULTI.C  
OS\_PRIO.C  
OS\_Q.C  
OS\_SEM.C  
OS\_STAT.C  
OS\_TASK.C  
OS\_TICK.C  
OS\_TIME.C  
OS\_TMR.C

## **D-4 MISRA-C:2004, RULE 15.2 (REQUIRED)**

### **Rule Description**

An unconditional break statement shall terminate every non-empty switch clause.

### **Offending code appears as**

```
switch (value) {
    case constant_value:
        /* Code */
        return;
}
```

### **Rule suppressed**

The problem involves using a return statement to exit the function instead of using a break. When adding a “break” statement after the return, the compiler complains about the unreachable code of the “break” statement.

### **Occurs in**

OS\_FLAG.C

OS\_MUTEX.C

OS\_Q.C

OS\_TMR.C

## **D-5 MISRA-C:2004, RULE 17.4 (REQUIRED)**

### **Rule Description**

Array indexing shall be the only allowed form of pointer arithmetic.

### **Offending code appears as**

```
:  
p_tcb++;  
:
```

### **Rule suppressed**

It is common practice in C to increment a pointer instead of using array indexing to accomplish the same thing. This common practice is not in agreement with this rule.

### **Occurs in**

OS\_CORE.C  
OS\_CPU\_C.C  
OS\_INT.C  
OS\_MSG.C  
OS\_PEND\_MULTI.C  
OS\_PRIO.C  
OS\_TASK.C  
OS\_TICK.C  
OS\_TMR.C



## Appendix

# E

## Bibliography

Bal Sathe, Dhananjay. 1988. *Fast Algorithm Determines Priority*. EDN (India), September, p. 237.

Comer, Douglas. 1984. *Operating System Design, The XINU Approach*. Englewood Cliffs, New Jersey: Prentice-Hall. ISBN 0-13-637539-1.

Kernighan, Brian W. and Dennis M. Ritchie. 1988. *The C Programming Language, 2nd edition*. Englewood Cliffs, New Jersey: Prentice Hall. ISBN 0-13-110362-8.

Klein, Mark H., Thomas Ralya, Bill Pollak, Ray Harbour Obenza, and Michael Gonzlez. 1993. *A Practioner's Handbook for Real-Time Analysis: Guide to Rate Monotonic Analysis for Real-Time Systems*. Norwell, Massachusetts: Kluwer Academic Publishers Group. ISBN 0-7923-9361-9.

Labrosse, Jean J. 2002, *MicroC/OS-II, The Real-Time Kernel*, CMP Books, 2002, ISBN 1-57820-103-9.

Li, Qing. *Real-Time Concepts for Embedded Systems*, CMP Books, July 2003, ISBN 1-57820-124-1.

The Motor Industry Software Reliability Association, *MISRA-C:2004*, Guidelines for the Use of the C Language in Critical Systems, October 2004. [www.misra-c.com](http://www.misra-c.com).



# F

## Licensing Policy

This book contains  $\mu$ C/OS-III, precompiled in linkable object form, and is accompanied by an evaluation board and tools (compiler/assembler/linker/debugger). The user may use  $\mu$ C/OS-III with the evaluation board that accompanied the book and it is not necessary to purchase anything else as long as the initial purchase is used for educational purposes. Once the code is used to create a commercial project/product for profit, however, it is necessary to purchase a license.

It is necessary to purchase this license when the decision to use  $\mu$ C/OS-III in a design is made, not when the design is ready to go to production.

If you are unsure about whether you need to obtain a license for your application, please contact Micrium and discuss the intended use with a sales representative.

### **CONTACT MICRIUM**

1290 Weston Road, Suite 306  
Weston, FL 33326  
USA

Phone: +1 954 217 2036  
Fax: +1 954 217 2037

E-mail: [Licensing@Micrium.com](mailto:Licensing@Micrium.com)  
Web: [www.Micrium.com](http://www.Micrium.com)





# Index

## A

adding tasks to the ready list .....131  
ANSI C .....19, 35, 323, 335, 637  
API .....20, 599  
API changes .....612  
app\_cfg.h .....52  
application code .....36  
application programming interface .....20, 599  
AppTaskStart() .....56–58, 65, 117–119  
asynchronously .....157

## B

background .....16, 19  
bilateral rendezvous .....271, 293–294  
binary semaphores .....217  
board support package .35, 38, 52, 337, 343, 345, 545, 634  
bounded .....233–234  
broadcast .....259, 287, 291, 311  
    on post calls .....73, 173  
    to a semaphore .....286  
BSP\_Init() .....52, 58, 64, 118, 343  
BSP\_LED\_On() .....52, 59, 343

## C

callback function .... 119, 193, 195–196, 207–208, 561, 564, 575–576  
clock tick .....173  
CLZ .....23, 124, 127, 604  
compile-time, configurable .....25, 81, 600  
configurable .....606  
    compile-time .....25, 81, 600  
    message queue .....291  
    OS\_StatTask() .....116, 591  
    OS\_TickTask() .....109  
    OS\_TmrTask() .....119, 200  
    run-time .....21, 25, 600  
conjunctive .....273  
consumer .....294–295  
contacting Micrium .....32  
context switch 23, 30, 70, 72, 80, 88, 99, 105, 108, 147, 149, 151, 154–155, 214, 217, 350, 352, 368, 388, 410, 430, 448, 452, 509, 525, 540

conventions .....27  
countdown .....22, 119, 194–197, 571  
counting semaphores .....224  
cpu\_a.asm .....44, 46, 48–49, 338, 340–342, 345, 545  
cpu\_c.c .....44, 46, 48–49, 338, 340  
cpu\_cfg.h .....44–45, 48, 53, 70, 74, 105, 338, 340, 352  
cpu\_core.c .....44–45, 48, 337–338, 340–341  
cpu\_core.h .....44–45, 48, 53, 338, 341  
CPU\_CRITICAL\_ENTER() .....45, 70, 72, 212–214, 340–341, 406, 484, 499, 503, 517, 530, 541, 560, 612  
CPU\_CRITICAL\_EXIT() .45, 70, 72, 212–214, 340–341, 406, 484, 499, 503, 517, 530, 541, 560, 612  
CPU\_DATA .....124–127, 339  
cpu\_def.h .....44–45, 48, 338  
CPU\_Init() .....58, 64, 340  
CPU\_STK .....53  
creating a memory partition .....324  
credit tracking .....257, 288  
critical region .....69, 358, 371

## D

data types (os\_type.h) .....593  
deadlock .....23–24, 230, 245–249, 600  
    prevention .....23–24, 600  
deadly embrace .....245  
deferred post .....134–135, 144, 166, 169, 171–175  
direct post .....134, 166–168, 170, 172–173, 175  
direct vs. deferred post method .....172  
disjunctive .....273

## E

ELF/DWARF .....27  
embedded systems .15, 21, 75, 77, 86, 164, 329, 333, 464, 491, 637, 643  
error checking .....22  
Ethernet .....18, 27, 33, 39, 78, 158, 267, 290, 292  
event flags .....24, 31, 73, 173, 177, 251, 259, 273–275, 277–280, 284, 286–288, 356–357, 380, 600, 613  
    internals .....279  
    synchronization .....380  
    using .....275

## F

features of  $\mu$ C/OS,  $\mu$ C/OS-II and  $\mu$ C/OS-III .....24  
 FIFO .... 65, 291, 298, 302, 306, 383–384, 448–450, 509–511  
 fixed-size memory partitions .....387  
 flow control .....294  
 footprint .....24, 371, 373, 600  
 foreground .....16, 19  
 foreground/background systems .....16  
 FPU .....86, 160  
 fragmentation .....82, 323–324, 333, 415, 464  
 free() .....323, 333

## G

general statistics – run-time .....348  
 getting a memory block from a partition .....328  
 granularity .....193, 596  
 GUI .....19

## H

hooks and port .....633

## I

idle task (OS\_IdleTask()) .....107  
 infinite loop 55, 59, 75, 77, 81, 107, 121, 348, 350, 487–488, 516, 634  
 internal tasks .....106  
 interrupt ... 69–71, 73–74, 120, 143, 157–167, 169–173, 175, 211–214, 250–251, 289, 344, 587, 595, 612  
   controller .....158–159, 163–165, 340, 344–345  
   disable .....70  
   disable time 45, 71, 74, 120, 157, 167–168, 170, 172, 211, 250, 347–348, 352  
   disable time, measuring .....70  
   disable/enable .....212  
   handler task .....120  
   latency ..58, 157, 168, 170, 173, 211, 213, 250, 352, 587, 601, 604  
   management .....157  
   recovery .....158, 168, 170–171  
   response .....157, 168, 170–171  
   vector to a common location .....163  
 interrupt service routine .....251, 330  
 intuitive .....20, 28, 84  
 ISR .....251, 330  
   epilogue .....162–163, 165, 168, 171  
   handler task .120–121, 129, 136, 501, 539, 581, 589, 595  
   handler task (OS\_IntQTask()) .....120  
   prologue .....162–165, 168, 170–171  
   typical  $\mu$ C/OS-III ISR .....159

## K

kernel awareness debuggers .....23  
 kernel object .....355

## L

LED .....26, 35, 59, 343  
 lib\_ascii.c .....46, 49  
 lib\_ascii.h .....46, 49  
 lib\_def.h .....46, 49  
 lib\_math.c .....46, 49  
 lib\_math.h .....46  
 lib\_mem.c .....46, 49  
 lib\_mem.h .....46, 49  
 lib\_mem\_a.asm .....46–47, 49  
 lib\_str.c .....46, 49  
 lib\_str.h .....46, 49  
 licensing .....27, 32, 645  
 LIFO .....291, 383–384, 448–450, 509–510  
 lock/unlock .....214  
 locking .....20, 71–74, 120, 138, 211, 214, 250, 289, 350  
 locking the scheduler .....71  
 low power .....108, 175, 406

## M

malloc() .....53, 82, 323, 325–328, 333, 414  
 MCU .....35–36, 38, 337  
 measuring interrupt disable time .....70  
 measuring scheduler lock time .....72  
 memory management .....617  
 memory management unit .....87  
 memory partitions ..297, 324, 326, 330, 333, 349, 357, 387, 414–415, 417, 420, 587  
 memory protection unit .....87  
 message mailboxes .....615  
 message passing .....31, 289, 383–384  
 message queue .31, 178, 289–297, 299–301, 303–305, 311, 313, 321, 615, 620–621, 627  
   configurable .....291  
   internals .....308  
   message passing .....383  
   OSQAbort() .....446  
   OSQCreate() .....436  
   OSQDel() .....438  
   OSQFlush() .....440  
   OSQPend() .....442  
   OSQPost() .....448  
   OSTaskQAbort() .....507  
   OSTaskQPend() .....504  
   OSTaskQPost() .....509  
   task .....292, 384  
   using .....299  
 messages .....290  
 migrating .....31, 599  
 miscellaneous .....631  
 MISRA-C  
   2004, Rule 14.7 (Required) .....639  
   2004, Rule 15.2 (Required) .....640  
   2004, Rule 17.4 (Required) .....641  
   2004, Rule 8.12 (Required) .....638  
   2004, Rule 8.5 (Required) .....638  
 MMU .....46, 87, 498

|                                 |   |
|---------------------------------|---|
| MPU                             | 87  |
| multiple tasks                  |   |
| application with kernel objects | 60  |
| waiting on a semaphore          | 259   |
| multitasking                    | 17, 20, 24, 75, 80, 121, 477, 487, 600        |
| mutual exclusion semaphore      | 234, 238–242, 250, 355–356, 421, 588, 618–619 |
| internals                       | 239   |
| resource management             | 379   |
| N                               |   |
| nested task suspension          | 22  |
| O                               |   |
| object names                    | 23  |
| one-shot timers                 | 195   |
| os_cfg_app.c                    | 371   |
| OSCtxSw()                       | 150, 388                                      |
| os_dbg.c                        | 358   |
| OSFlagCreate()                  | 390   |
| OSFlagDel()                     | 392   |
| OSFlagPend()                    | 77, 394, 488                                  |
| OSFlagPendAbort()               | 398   |
| OSFlagPendGetFlagsRdy()         | 401   |
| OSFlagPost()                    | 403   |
| OSIdleTaskHook()                | 405   |
| OSInit()                        | 129, 407                                      |
| OSInitHook()                    | 409   |
| OSIntCtxSw()                    | 153, 410, 540                                 |
| OSIntEnter()                    | 412   |
| OSIntExit()                     | 143, 413                                      |
| OS_IntQTask()                   | 120   |
| OSMemCreate()                   | 414   |
| OSMemGet()                      | 417   |
| OSMemPut()                      | 224, 419                                      |
| OSMutexCreate()                 | 421   |
| OSMutexDel()                    | 423   |
| OSMutexPend()                   | 77, 237–238, 425, 488                         |
| OSMutexPendAbort()              | 428   |
| OSMutexPost()                   | 430   |
| OSPendMulti()                   | 77, 432                                       |
| OSQCreate()                     | 436   |
| OSQDel()                        | 438   |
| OSQFlush()                      | 440   |
| OSQPend()                       | 77, 442, 488                                  |
| OSQPendAbort()                  | 446   |
| OSQPost()                       | 448   |
| OSSafetyCriticalStart()         | 451   |
| OSSched()                       | 142, 452                                      |
| OSSchedLock()                   | 454   |
| OS_SchedRoundRobin()            | 144   |
| OSSchedRoundRobinCfg()          | 456   |
| OSSchedRoundRobinYield()        | 458   |
| OSSchedUnlock()                 | 460   |

|                             |  |
|-----------------------------|--|
| OSSemCreate()               | 462  |
| OSSemDel()                  | 464  |
| OSSemPend()                 | 77, 467, 488   |
| OSSemPendAbort()            | 470  |
| OSSemPost()                 | 472  |
| OSSemSet()                  | 475  |
| OSStart()                   | 477  |
| OSStartHighRdy()            | 479  |
| OSStatReset()               | 481  |
| OS_StatTask()               | 591  |
| configurable                | 116  |
| OSStatTaskCPUUsagelnit()    | 482  |
| OSStatTaskHook()            | 483  |
| OSTaskChangePrio()          | 485  |
| OSTaskCreate()              | 131, 487   |
| OSTaskCreateHook()          | 80, 498  |
| OSTaskDel()                 | 77, 488, 500   |
| OSTaskDelHook()             | 502  |
| OSTaskQPend()               | 77, 488, 504   |
| OSTaskQPendAbort()          | 507  |
| OSTaskQPost()               | 509  |
| OSTaskRegGet()              | 512  |
| OSTaskRegSet()              | 514  |
| OSTaskResume()              | 518  |
| OSTaskReturnHook()          | 516  |
| OSTaskSemPend()             | 77, 488, 520   |
| OSTaskSemPendAbort()        | 523  |
| OSTaskSemPost()             | 525  |
| OSTaskSemSet()              | 527  |
| OSTaskStatHook()            | 529  |
| OSTaskStkChk()              | 531  |
| OSTaskStkInit()             | 534, 537   |
| OSTaskSuspend()             | 77, 488, 538   |
| OSTaskSwHook()              | 540  |
| OSTaskTimeQuantaSet()       | 543  |
| OSTickISR()                 | 545  |
| OSTimeDly()                 | 77, 114, 184–185, 187, 488, 547  |
| OSTimeDlyHMSM()             | 77, 189, 488, 550  |
| OSTimeDlyResume()           | 191, 553   |
| OSTimeGet()                 | 555  |
| OSTimeSet()                 | 556  |
| OSTimeSet() and OSTimeGet() | 192  |
| OSTimeTick()                | 110, 192, 558  |
| OSTimeTickHook()            | 559  |
| OSTmrCreate()               | 205, 561   |
| OSTmrDel()                  | 567  |
| OSTmrRemainGet()            | 569  |
| OSTmrStart()                | 571  |
| OSTmrStateGet()             | 573  |
| OSTmrStop()                 | 575  |
| OS_TmrTask(), configurable  | 119, 200   |
| OS_TS_GET()                 | 52, 66, 105, 168, 171, 220, 231, 244, 262, 269, 281, 304, 342, 395, 426, 443, 468, 505, 521, 542 |
| OSVersion()                 | 577  |

## P

partition .... 296–297, 323–333, 357, 414–415, 417, 419–420  
 partition memory manager ..... 587  
 pend  
   lists ..... 30, 120, 177, 182  
   on a task semaphore ..... 268  
   on multiple objects ... 22, 25, 73, 173, 313, 363, 385, 601  
 periodic (no initial delay) ..... 196  
 periodic (with initial delay) ..... 196  
 periodic interrupt ..... 183  
 peripherals ..... 15, 35, 83, 337  
 per-task statistics - run-time ..... 352  
 polling ..... 157  
 porting ..... 31, 147, 335, 337  
 posting (i.e. signaling) a task semaphore ..... 269  
 preemption lock ..... 69  
 preemptive scheduling ..... 84, 134–135  
 priority ... 65, 67, 73, 137–138, 144, 146, 150, 155, 157–158, 165, 173, 200, 251, 257, 259, 286, 353, 355, 479, 485, 509, 588–589, 600  
   inheritance ..... 21, 211, 235, 250  
   inversion ..... 226, 232–233  
   level ..... 21, 124, 127–128, 131–132  
   OS\_StatTask() ..... 591  
   OS\_TmrTask() ..... 200  
   pend list ..... 177  
   priority ready bitmap ..... 141  
   round-robin scheduling ..... 20  
 producer ..... 294–295  
 protocol mechanism ..... 215, 252

## R

ready list ..... 30, 93, 120, 123, 128–132, 177, 498, 502  
   adding tasks ..... 131  
 real-time kernels ..... 17  
 real-time operating system ..... 19, 109  
 reentrant ..... 76–77, 238, 247, 335  
 rendezvous ..... 254, 271, 286–287, 293–294  
 resource sharing ..... 211  
 response time ..... 16, 22, 157, 278  
 retriggering ..... 195  
 returning a memory block to a partition ..... 329  
 RMS ..... 84–85  
 ROMable ..... 13, 19, 21, 24, 600  
 round-robin scheduling ..... 138  
 run-time configurable ..... 21, 25, 600

## S

scalable ..... 13, 19–20, 24, 600  
 scheduling algorithm ..... 174–175  
 scheduling internals ..... 141  
 scheduling points ..... 136, 146

semaphore ... 61, 80, 102–103, 180, 211, 215–234, 238–242, 245, 247, 250, 252–271, 273, 286–289, 295–296, 313, 317, 319, 332–333, 353–356, 421, 432, 462–465, 467–473, 475–476, 494, 523, 525–527, 538, 588, 590, 600, 618–619, 622–623, 627  
   internals (for resource sharing) ..... 227  
   internals (for synchronization) ..... 260  
   synchronization ..... 381  
 servers ..... 307  
 short interrupt service routine ..... 162  
 single task application ..... 52  
 software timers ..... 21–22, 24, 30, 42, 600  
 source files ..... 602  
 stack 78–80, 82–83, 86–90, 94, 98–100, 103–104, 116, 119, 121, 147–149, 160–161, 179, 182, 335, 338, 354, 389, 405, 490–494, 496–498, 531–532, 534–537, 546, 581, 591–592, 594–597, 603, 605, 628, 634  
   pointer ..... 147, 149  
   size ..... 86  
 stack overflows ..... 86–87, 89–90  
 statistic task (OS\_StatTask()) ..... 116  
 statistics 28, 31, 116–117, 119, 121, 347–348, 352, 483, 531, 591, 604  
 status ..... 98, 391, 572  
 superloops ..... 16  
 switched in ..... 88, 93, 388–389, 410, 540  
 synchronization ..... 273  
 synchronizing multiple tasks ..... 286  
 system tick ..... 109, 173, 175

## T

## task

adding to the readylist ..... 131  
 latency ..... 158, 168, 170–171, 353, 590  
 management ..... 376, 624  
 message ..... 22  
 message queue ..... 292, 384  
 registers ..... 22, 25, 102, 512, 514, 601  
 semaphore ..... 267–269, 271, 288, 295–296, 527  
 semaphores, synchronization ..... 382  
 signals ..... 22, 28, 133, 136, 265, 269, 321  
 stack overflows ..... 87  
 states ..... 92  
 task control block ..... 53, 78, 97, 310  
 task management  
   internals ..... 92  
   services ..... 91  
 thread ..... 17, 75  
 tick task (OS\_TickTask()) ..... 109  
 tick wheel ..... 31, 100, 113, 348, 373, 582, 594  
 time management ..... 21, 26, 30, 183, 378, 628–629  
 time quanta ..... 495  
 time slicing ..... 104, 138, 543  
 time stamps ..... 25, 58, 601  
 timeouts ..... 23, 109, 174–175, 183, 192, 558, 596

|                                 |  |
|---------------------------------|--|
| timer management .....          | 629  |
| internals .....                 | 197  |
| internals - OS_TMR .....        | 198  |
| internals - Timer List .....    | 203  |
| internals - Timer Task .....    | 200  |
| internals - Timers States ..... | 197  |
| timer task (OS_TmrTask()) ..... | 119  |
| timer wheel .....               | 203, 205, 373, 582, 594, 597   |
| timers .....                    | 119, 175, 193, 195–196, 203–204, 208, 386  |
| timestamp .....                 | 71–72, 174, 180, 220, 228–229, 231, 240, 242, 244, 262, 269, 278, 281, 283, 290, 304, 308, 317, 331, 340, 343, 355–357, 395, 426, 434, 443, 468, 505, 521, 616, 621, 623 |
| TOS .....                       | 480  |
| transient events .....          | 278–279  |

## U

|  |                                 |
|--|---------------------------------|
| UARTs .....  | 33                              |
| unbounded priority inversion .....                 | 21, 211, 232–234, 240, 245, 250 |
| unilateral rendezvous .....                        | 254, 271                        |
| universal asynchronous receiver transmitters ..... | 33                              |
| unlock .....                                       | 214                             |
| unlocking .....                                    | 120, 211, 250                   |
| USB .....  | 27                              |
| user definable hooks .....                         | 23                              |
| using event flags .....                            | 275                             |
| using memory partitions .....                      | 330                             |

## V

|                             |                                 |
|-----------------------------|---------------------------------|
| variable name changes ..... | 611                             |
| vector .....                | 76, 158–159, 163, 165, 175, 545 |
| vector address .....        | 158, 163                        |

## W

|                                     |                               |
|-------------------------------------|-------------------------------|
| wait lists .....                    | 26, 30, 120, 177              |
| walks the stack .....               | 89                            |
| watermark .....                     | 56, 79, 99, 491, 495–496, 535 |
| what is $\mu$ C/OS-III? .....       | 13                            |
| what's new about this book? .....   | 14                            |
| why a new $\mu$ C/OS version? ..... | 13                            |

## Y

|                |     |
|----------------|-----|
| yielding ..... | 138 |
|----------------|-----|

## $\mu$

|                                  |           |
|----------------------------------|-----------|
| $\mu$ C/FS .....                 | 19        |
| $\mu$ C/GUI .....                | 19        |
| $\mu$ C/LIB .....                | 35, 46–47 |
| portable library functions ..... | 46        |

|  |  |
|--|--|
| $\mu$ C/OS-III .....                         | 19   |
| features .....                               | 24   |
| features (os_cfg.h) .....                    | 583  |
| features with longer critical sections ..... | 73   |
| goals .....                                  | 14   |
| porting .....                                | 341  |
| stacks, pools and other (os_cfg_app.h) ..... | 594  |
| $\mu$ C/OS-III convention changes .....      | 605  |
| $\mu$ C/Probe .....                          | 23, 26–28, 37, 41, 101, 103, 199, 218, 227, 239, 241, 261, 263, 280, 282, 347, 359, 373, 390, 414, 421, 436, 462, 489, 563 |
| $\mu$ C/TCP-IP .....                         | 19   |
| $\mu$ C/USB .....                            | 19   |

Index

---