

UNIT:MM

REVISION INFORMATION

Rev.	Rev. Date	Modified By	Brief Description
A/0	18-07-24	T0721A	NEW DRAWING

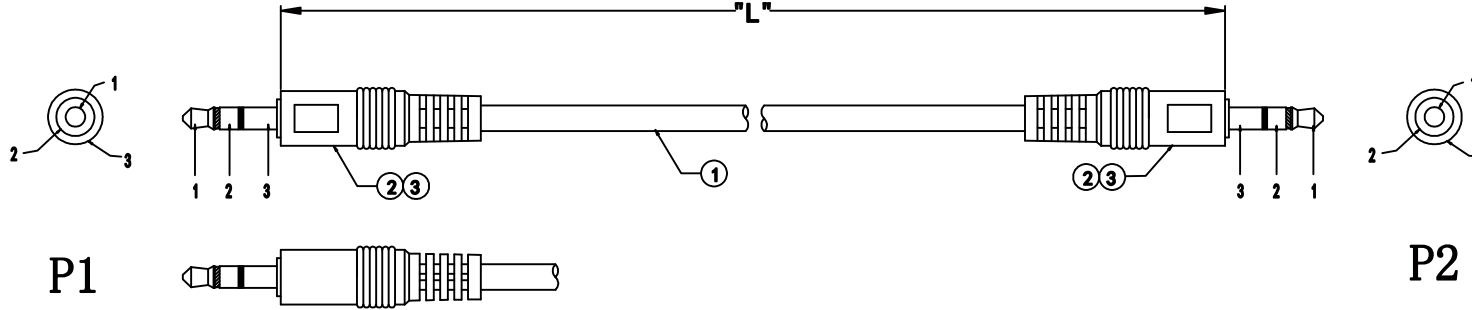

PIN ASSIGNMENT

P1	P2
1 RED	1
2 BLACK	2
3 BRAID	3

PART NO	WIRE LENGTH "L"	BUYER COLOR	VENDOR COLOR	CUT LENGTH
770-10040-00050	500±10		BLACK	500-510MM

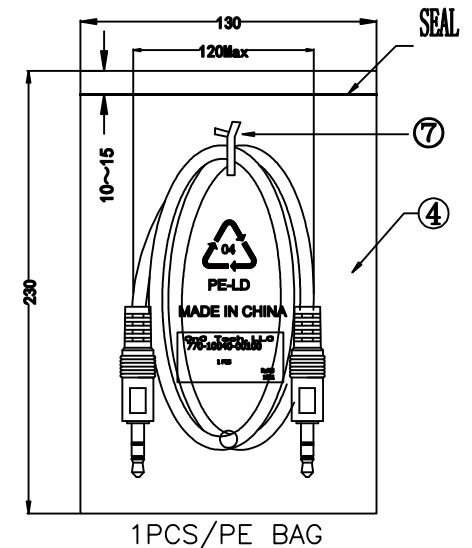

NO.	NAME	QTY	SPECIFICATION
⑦	TIE	1	BLACK L=70MM
⑥	TUBE	2	HEAT SHRINK TUBE BLACK OD1.5*L15MM
⑤	PE BAG	1/10	CLEAR SIZE:280X330X0.05mm PRINT BLACK"MADE IN CHINA "+*10PCS"
④	PE BAG	1	CLEAR SIZE:130X230X0.05mm PRINT BLACK "MADE IN CHINA"
③	OUT JACKET		OUTER MODEL PVC 45P COLOR BLACK (MOULD NO:WM-020)
②	CONN	2	3.5ST MALE Tray6.0mm L=30mm MOLD TYPE NI-PLATED INSULATOR COLOR:BLACK
①	CABLE	1	NOUL 28AWG (7/0.12TC) X2C (RED, WHITE) + (36/0.12) JACKET BLACK OD:3.0MM

**CnC Tech, LLC**  
Industrial Cable and Connector Technology

DRAWN BY:	DATE: 2018/07/24	DESCRIPTION: 2C CABLE DC3.5+DC3.5
CHECKED BY:	SHEET 1 of 1	ITEM NO. As above
APPROVED BY:	SCALE 1:1	REV. A/0 UNIT: mm