

## 【1. 適用範囲 SCOPE】

本仕様書は、\_\_\_\_\_ 殿 に納入する

Mini-Lock 2.5 電線対基板用 コネクタ スルーホールタイプ / SMTタイプ \_\_\_\_\_ について規定する。

This product specification covers the performance requirements for Mini-Lock 2.5 WIRE TO BOARD CONNECTOR Through Hole type / SMT type series for limited use by \_\_\_\_\_ .

## 【2. 製品名称及び型番 PRODUCT NAME AND PART NUMBER】

製品名称 Product Name			製品型番 Part Number
リセプタクル Receptacle	ハウジング (リテーナー対応) Housing (Corresponds to Retainer)	色 : ナチュラル、黒 Color : Natural, Black	51163****(*1)
	ターミナル (リテーナー対応) Terminal(Corresponds to Retainer)	AWG#20-#22	507528200
		AWG#24-#26	507528400
リテーナー (リセプタクルハウジング対応) Retainer(Corresponds to Receptacle Housing)			51164**05(*1)
プラグ アセンブリ スルーホールタイプ Plug Assembly Through Hole Type	バーティカルタイプ Vertical Type	色 : ナチュラル Color : Natural	53375**10
		色 : ナチュラル Color : Natural	53476**10(*1)
	バーティカルタイプ ポッティング対応 Vertical Type Potting	色 : ナチュラル、黒 Color : Natural, Black	53517****(*1)
	ライトアングルタイプ Right Angle Type	色 : ナチュラル Color : Natural	53426**10
		色 : ナチュラル、黒 Color : Natural, Black	534269***(*1)
プラグ アセンブリ SMTタイプ Plug Assembly SMT Type	バーティカルタイプ Vertical Type	色 : ナチュラル、黒 Color : Natural, Black	215931**7*(*1)
	ライトアングルタイプ Right Angle Type	色 : ナチュラル、黒 Color : Natural, Black	215932**7*(*1)

\* : 図面参照 Refer to the drawing

取扱についてはコネクタ取扱説明書” 2166940000-AS PS 000を参照願います。

Application specification : Refer to 2169940000-AS PS 000

(※1) : Glow wire test適合品

Glow wire test compatible

EN 60695-2-11-2001 / IEC 60695-2-11-2000のGlow Wire Testに準拠していることを確認しています。

They were tested and found compliant with EN 60695-2-11-2001 / IEC 60695-2-11-2000 Glow Wire Test Methods.

THIS DOCUMENT CONTAINS INFORMATION THAT IS PROPRIETARY TO MOLEX ELECTRONIC TECHNOLOGIES, LLC AND SHOULD NOT BE USED WITHOUT WRITTEN PERMISSION

REVISION DESCRIPTION	REVISED	MINI-LOCK 2.5 W/B CONNECTOR					
CHANGE NO.	652870						
REVISED BY	MIKEDA01	DATE	2023/03/27	DOC TYPE	DOC TYPE DESCRIPTION	DOC PART	SERIES
REV APPR BY	AIDA	DATE	2023/05/15	PS	ENGINEERING SPECIFICATION WORD	000	51163
INITIAL RELEASE				CUSTOMER	DOCUMENT NUMBER	REVISION	SHEET
INITIAL DRWN	RWATANABE01	DATE	2018/09/07	GENERAL	511630000-PS	H	1 OF 21
INITIAL APPR	TKANEKO	DATE	2018/09/10				

## 【3. 定格及び適合電線 RATINGS AND APPLICABLE WIRES】

項目 Item	規格 Standard	
最大許容電圧 Allowable Voltage (MAX.)	250 V [ AC (実効値 rms) / DC ]	
最大許容電流 及び 適合電線 Allowable Current ( MAX. ) And Applicable wires	AWG#20	3.5 A
	AWG#22	3.0 A
	AWG#24	2.5 A
	AWG#26	2.0 A
使用温度範囲*1*2*3 Ambient Temperature Range	-55°C ~ +105°C 低温において氷結しないこと Not freeze in low temperature	

\*1: 基板実装後の無通電状態は、使用温度範囲が適用されます。

Non-operating connectors after reflow must follow the operating temperature range condition.

\*2: 通電による温度上昇分を含む。

This includes the terminal temperature rise generated by conducting electricity.

\*3: 適合電線も本使用温度範囲を満足すること。

Applicable wires must also meet the specified temperature range.

## 参考許容電流 CURRENT DERATING REFERENCE INFORMATION

AWG	2-circuits	7-circuits	15-circuits
	Amps (A)	Amps (A)	Amps (A)
20	5.0	3.5	3.5
22	4.5	3.0	3.0
24	4.0	2.5	2.5
26	3.5	2.5	2.0

1) 各電流値は参考となります。

Values are for REFERENCE ONLY

2) 閾値は温度上昇30°C以下としています。

Current deratings are based on not exceeding 30 °C Temperature Rise.

3) 温度上昇の測定は圧着端子のバレル部にて実施しています。

Temperature Rise is measured in barrel area of crimp terminal.

4) 基板デザインにより温度上昇の結果が異なります。

PCB trace design can greatly affect temperature rise results.

5) 全極に通電し測定しています。

Data is for all circuits powered.

THIS DOCUMENT CONTAINS INFORMATION THAT IS PROPRIETARY TO MOLEX ELECTRONIC TECHNOLOGIES, LLC AND SHOULD NOT BE USED WITHOUT WRITTEN PERMISSION

REVISION DESCRIPTION	REVISED	MINI-LOCK 2.5 W/B CONNECTOR					
CHANGE NO.	652870						
REVISED BY	MIKEDA01	DATE	2023/03/27	DOC TYPE	DOC TYPE DESCRIPTION	DOC PART	SERIES
REV APPR BY	AIDA	DATE	2023/05/15	PS	ENGINEERING SPECIFICATION WORD	000	51163
INITIAL RELEASE			CUSTOMER		DOCUMENT NUMBER		REVISION SHEET
INITIAL DRWN	RWATANABE01	DATE	2018/09/07	GENERAL		511630000-PS	H 2OF21
INITIAL APPR	TKANEKO	DATE	2018/09/10				

## 【4. 性能 PERFORMANCE】

## 4-1. 電気的性能 Electrical performance

項目 Item		条件 Test Condition	規格 Requirement
4-1-1	接触抵抗 Contact Resistance	コネクタを嵌合させ、開放電圧 20mV以下、短絡電流 10mA 以下にて測定する。但し、電線部の導体抵抗は差し引く。接触抵抗測定箇所は第8項を参照のこと。 (JIS C5402-2-1)  Mate connectors and measured by dry circuit, 20 mV MAX., 10 mA.MAX. and subtract wire conductor resistance. Refer to paragraph 8 for Contact resistance measuring point. (JIS C5402-2-1)	20 milliohms MAX.
4-1-2	絶縁抵抗 Insulation Resistance	コネクタを嵌合させ、隣接するターミナル間及びターミナル、アース間に、DC 500Vを印加し測定する。 (JIS C5402-3-1/MIL-STD-202 試験法 302)  Mate connectors and apply 500 V DC between adjacent terminals or between terminal and ground. (JIS C5402-3-1/MIL-STD-202 Method 302)	1000 Megohms MIN.
4-1-3	耐電圧 Dielectric Strength	コネクタを嵌合させ、隣接するターミナル間及びターミナル、アース間に、AC 1000V 実効値を1分間 印加する (JIS C5402-4-1/MIL-STD-202 試験法 301)  Mate connectors and apply 1,000 V AC rms for 1 minute between adjacent terminal or ground. (JIS C5402-4-1/MIL-STD-202 Method 301)	製品機能を損なう異常なきこと No Damage on function
4-1-4	圧着部接触抵抗 Contact Resistance on Crimped Portion	ターミナルに適合電線を圧着し、開放電圧20mV以下、短絡電流 10mA 以下にて測定する。  Crimp the applicable wire to the terminal, measured by dry circuit, 20 mV MAX., 10 mA.MAX.	5 milliohms MAX.

THIS DOCUMENT CONTAINS INFORMATION THAT IS PROPRIETARY TO MOLEX ELECTRONIC TECHNOLOGIES, LLC AND SHOULD NOT BE USED WITHOUT WRITTEN PERMISSION

REVISION DESCRIPTION	REVISED	<b>MINI-LOCK 2.5 W/B CONNECTOR</b>					
CHANGE NO.	652870						
REVISED BY	MIKEDA01	DATE	2023/03/27	DOC TYPE	DOC TYPE DESCRIPTION	DOC PART	SERIES
REV APPR BY	AIDA	DATE	2023/05/15	PS	ENGINEERING SPECIFICATION WORD	000	51163
INITIAL RELEASE				CUSTOMER	DOCUMENT NUMBER	REVISION	SHEET
INITIAL DRWN	RWATANABE01	DATE	2018/09/07	GENERAL	<b>511630000-PS</b>	<b>H</b>	3OF21
INITIAL APPR	TKANEKO	DATE	2018/09/10				

4-2. 機械的性能 Mechanical Performance

項 目 Item		条 件 Test Condition		規 格 Requirement
4-2-1	挿入力及び抜去力 Insertion and Withdrawal Force	手挿抜にて挿入、抜去を行う。 但し、ロックは解除して行う。 Insert and withdraw connectors with hand. The data is measured when the housing lock is removed.		第6項参照 Refer to section 6
4-2-2	圧着部引張強度 Crimping Pull out Force	圧着されたターミナルを治具に 固定し、電線を軸方向に 毎分25±3mmの速さで引張る。 (JIS C5402-16-4) Fix the crimped terminal to the jig, apply axial pull out force on the wire at the speed rate of 25 ±3 mm/minute. (JIS C5402-16-4)	AWG#20	49.0 N{5.0kgf}MIN.
			AWG#22	39.2 N{4.0kgf}MIN.
			AWG#24	29.4 N{3.0kgf}MIN.
			AWG#26	19.6 N{2.0kgf}MIN.
4-2-3	圧着端子挿入力 Crimp Terminal Insertion Force	圧着されたターミナルをハウジングに挿入する。 Insert a crimped terminal into the housing.		9.8 N {1.0kgf} MAX.
4-2-4	圧着端子保持力 Crimp Terminal Retention Force	ハウジングに装着した圧着されたターミナルを 毎分 25±3mm の速さで軸方向に引張る。 Apply axial pull out force at the speed rate of 25 ±3 mm/minute on a crimped terminal assembled in the housing.		14.7 N{1.5kgf}MIN.
4-2-5	プラグピン保持力 Plug Pin Retention Force	プラグハウジングに装着されたピンを毎分 25±3mmの速さで軸方向に引張る。 Apply axial pull out force at the speed rate of 25 ±3 mm/minute on a plug pin assembled in the plug housing.		[Through Hole Type] 14.7 N {1.5kgf} MIN.  [SMT Type] 9.8 N {1.0kgf} MIN.
4-2-6	ハウジングロック強度 [ポジティブロック] Housing Lock Strength [ Positive Lock ]	コネクタを嵌合させ、軸方向に毎分25±3mmの 速さで引張る。 Mate connectors and apply axial pull out force at the speed rate of 25 ±3 mm/minute.		[2極(2ckt)] 19.6 N {2.0kgf} MIN.  [3極以上(3ckt or more)] 29.4 N {3.0kgf} MIN.
4-2-7	リテーナー装着力 Retainer Insertion Force	毎分25±3mmの速さでハウジングにリテーナーを装 着する。 Insert a retainer into a housing at the speed rate of 25 ±3 mm/minute.		4.9 N {0.5kgf} MAX.

THIS DOCUMENT CONTAINS INFORMATION THAT IS PROPRIETARY TO MOLEX ELECTRONIC TECHNOLOGIES, LLC AND SHOULD NOT BE USED WITHOUT WRITTEN PERMISSION

REVISION DESCRIPTION	REVISED	<b>MINI-LOCK 2.5 W/B CONNECTOR</b>					
CHANGE NO.	652870						
REVISED BY	MIKEDA01	DATE	2023/03/27	DOC TYPE	DOC TYPE DESCRIPTION	DOC PART	SERIES
REV APPR BY	AIDA	DATE	2023/05/15	PS	ENGINEERING SPECIFICATION WORD	000	51163
INITIAL RELEASE				CUSTOMER	DOCUMENT NUMBER	REVISION	SHEET
INITIAL DRWN	RWATANABE01	DATE	2018/09/07	GENERAL	<b>511630000-PS</b>	<b>H</b>	4 OF 21
INITIAL APPR	TKANEKO	DATE	2018/09/10				

4-3. 環境性能、その他 Environmental Performance and Others

項目 Item		条件 Test Condition	規格 Requirement	
4-3-1	繰り返し挿抜 Repeated Insertion / Withdrawal	1分間 10回 以下の速さで、挿入、抜去を30回 繰り返す。 Insert and withdraw connectors up to 30 cycles repeatedly at speed rate of 10 cycles per minute maximum.	接触抵抗 Contact Resistance	40 milliohms MAX.
4-3-2	温度上昇 Temperature Rise	コネクタを嵌合させ、全ての圧着端子を直列に接続し最大許容電流で熱平衡に達した時の温度上昇を測定する。(UL498) Mate connectors and all crimp terminals shall be connected in a direct series. The temperature rise shall be measured when maximum rated current is flowed and thermal equilibrium reaches. (UL498)	温度上昇 Temperature Rise	30 °C MAX.
4-3-3	耐振動性 Vibration	コネクタを嵌合させ、DC 1mA 通電状態にて、嵌合軸を含む互いに垂直な 3方向に 掃引割合 10~55~10 Hz/分、全振幅 1.5mm の振動を各2時間 加える。 ケーブルは固定すること。 (JIS C 60068-2-6/MIL-STD-202 試験法 201) Mate connectors and conduct test subject to the following vibration conditions, for a period of 2 hours in each of 3 mutually perpendicular axes, passing DC 1mA during the test. Cables should be fixed during the test. Amplitude : 1.5 mm P-P Frequency : 10~55~10 Hz in 1 minute. Duration : 2 hours in each X.Y.Z.axes. (JIS C 60068-2-6/MIL-STD-202 Method 201)	外観 Appearance	製品機能を損なう異常なきこと No Damage on function
			接触抵抗 Contact Resistance	40 milliohms MAX.
			瞬断 Discontinuity	1.0 microsecond MAX.

THIS DOCUMENT CONTAINS INFORMATION THAT IS PROPRIETARY TO MOLEX ELECTRONIC TECHNOLOGIES, LLC AND SHOULD NOT BE USED WITHOUT WRITTEN PERMISSION

REVISION DESCRIPTION	REVISED	<b>MINI-LOCK 2.5 W/B CONNECTOR</b>						
CHANGE NO.	652870							
REVISED BY	MIKEDA01	DATE	2023/03/27	DOC TYPE	DOC TYPE DESCRIPTION	DOC PART	SERIES	
REV APPR BY	AIDA	DATE	2023/05/15	PS	ENGINEERING SPECIFICATION WORD	000	51163	
INITIAL RELEASE				CUSTOMER	DOCUMENT NUMBER	REVISION	SHEET	
INITIAL DRWN	RWATANABE01	DATE	2018/09/07	GENERAL	<b>511630000-PS</b>	<b>H</b>	5 OF 21	
INITIAL APPR	TKANEKO	DATE	2018/09/10					

項 目 Item		条 件 Test Condition	規 格 Requirement	
4-3-4	耐 衝 撃 性 Mechanical Shock	コネクタを嵌合させ、DC 1mA 通電状態にて、テストパルス半周期、嵌合軸を含む互いに垂直な 6方向 に 490m/s <sup>2</sup> { 50G }、作用時間11msの衝撃を各3回、合計18回加える。 (JIS C60068-2-27/MIL-STD-202 試験法 213)  Mate connectors and conduct test subject to the following shock conditions. 3 shocks shall be applied 6 directions along 3 mutually perpendicular axes, passing DC 1 mA current during the test. [Total of 18 shocks] Test pulse : Half Sine Peak value : 490 m/s <sup>2</sup> {50 G} Duration : 11 ms (JIS C60068-2-27/MIL-STD-202 Method 213)	外 観 Appearance	製品機能を損なう異常なきこと No Damage on function
			接 触 抵 抗 Contact Resistance	40 milliohms MAX.
			瞬 断 Discontinuity	1.0 microsecond MAX.

THIS DOCUMENT CONTAINS INFORMATION THAT IS PROPRIETARY TO MOLEX ELECTRONIC TECHNOLOGIES, LLC AND SHOULD NOT BE USED WITHOUT WRITTEN PERMISSION

REVISION DESCRIPTION	REVISED	<b>MINI-LOCK 2.5 W/B CONNECTOR</b>					
CHANGE NO.	652870						
REVISED BY	MIKEDA01	DATE	2023/03/27	DOC TYPE	DOC TYPE DESCRIPTION	DOC PART	SERIES
REV APPR BY	AIDA	DATE	2023/05/15	PS	ENGINEERING SPECIFICATION WORD	000	51163
INITIAL RELEASE				CUSTOMER	DOCUMENT NUMBER	REVISION	SHEET
INITIAL DRWN	RWATANABE01	DATE	2018/09/07	GENERAL	<b>511630000-PS</b>	<b>H</b>	6 OF 21
INITIAL APPR	TKANEKO	DATE	2018/09/10				

項目 Item		条件 Test Condition	規格 Requirement	
4-3-5	耐熱性 Heat Resistance	コネクタを嵌合させ、105±2°C の雰囲気中に96時間放置後取り出し、1~2時間室温に放置する。 (JIS C60068-2-2/MIL-STD-202 試験法 108)  Mate connectors and expose to 105 ±2 °C for 96 hours. Upon completion of the exposure period, the test specimens shall be left at ambient room temperature for 1 to 2 hours. After that, the measurements shall be performed. (JIS C60068-2-2/MIL-STD-202 Method 108)	外観 Appearance	製品機能を損なう異常なきこと No Damage on function
			接触抵抗 Contact Resistance	40 milliohms MAX.
4-3-6	耐寒性 Cold Resistance	コネクタを嵌合させ、-55±3°C の雰囲気中に96時間 放置後取り出し、1~2時間 室温に放置する。(JIS C60068-2-1)  Mate connectors and expose to -55 ±3 °C for 96 hours. Upon completion of the exposure period, the test specimens shall be left at ambient room temperature for 1 to 2 hours. After that, the measurements shall be performed. (JIS C60068-2-1)	外観 Appearance	製品機能を損なう異常なきこと No Damage on function
			接触抵抗 Contact Resistance	40 milliohms MAX.
4-3-7	耐湿性 Humidity	コネクタを嵌合させ、60±2°C、相対湿度90~95% の雰囲気中に 96時間 放置後取り出し、1~2時間 室温に放置する。 (JIS C60068-2-78/MIL-STD-202 試験法 103)  Mate connectors and expose to 60 ±2 °C, relative humidity 90 to 95 % for 96 hours. Upon completion of the exposure period, the test specimens shall be left at ambient room temperature for 1 to 2 hours. After that, the measurements shall be performed. (JIS C60068-2-78/MIL-STD-202 Method 103)	外観 Appearance	製品機能を損なう異常なきこと No Damage on function
			接触抵抗 Contact Resistance	40 milliohms MAX.
			絶縁抵抗 Insulation Resistance	100 Megohms MIN.
			耐電圧 Dielectric Strength	4-1-3項満足のこと Must meet 4-1-3

THIS DOCUMENT CONTAINS INFORMATION THAT IS PROPRIETARY TO MOLEX ELECTRONIC TECHNOLOGIES, LLC AND SHOULD NOT BE USED WITHOUT WRITTEN PERMISSION

REVISION DESCRIPTION	REVISED	<b>MINI-LOCK 2.5 W/B CONNECTOR</b>					
CHANGE NO.	652870						
REVISED BY	MIKEDA01	DATE	2023/03/27	DOC TYPE	DOC TYPE DESCRIPTION	DOC PART	SERIES
REV APPR BY	AIDA	DATE	2023/05/15	PS	ENGINEERING SPECIFICATION WORD	000	51163
INITIAL RELEASE				CUSTOMER	DOCUMENT NUMBER	REVISION	SHEET
INITIAL DRWN	RWATANABE01	DATE	2018/09/07	GENERAL	<b>511630000-PS</b>	<b>H</b>	7 OF 21
INITIAL APPR	TKANEKO	DATE	2018/09/10				

項目 Item		条件 Test Condition	規格 Requirement	
4-3-8	温度サイクル Temperature Cycling	<p>コネクタを嵌合させ、<math>-55\pm 3^{\circ}\text{C}</math> に 30分、<math>+105\pm 2^{\circ}\text{C}</math> に 30分。これを1サイクルとし、5サイクル 繰返す。 但し、温度移行時間は 5分以内 とする。 試験後1~2時間 室温に放置する。 (JIS C60068-2-14)</p> <p>Mate connectors and conduct test subject to the following conditions for 5 cycles. Upon completion of the exposure period, the test specimens shall be left at ambient room temperature for 1 to 2 hours. After that, the measurements shall be performed. 5 cycles of : a) <math>-55 \pm 3^{\circ}\text{C}</math>      30 minutes b) <math>+105 \pm 2^{\circ}\text{C}</math>      30 minutes Shifting time : within 5 minutes (JIS C60068-2-14)</p>	外 観 Appearance	製品機能を損なう 異常なきこと No Damage on function
			接 触 抵 抗 Contact Resistance	40 milliohms MAX.
4-3-9	塩 水 噴 霧 Salt Spray	<p>コネクタを嵌合させ、<math>35\pm 2^{\circ}\text{C}</math> にて <math>5\pm 1\%</math> 重量比の塩水を <math>48\pm 4</math>時間噴霧し、試験後 常温で水洗いした後、室温で乾燥させる。 (JIS C60068-2-11/MIL-STD-202 試験法101)</p> <p>Mate connectors and expose to the following salt mist conditions. Upon completion of the exposure period, salt deposits shall be removed by a gentle water wash or dip in running water. After that the measurements shall be performed. NaCl solution Concentration : <math>5 \pm 1\%</math> Spray time : <math>48 \pm 4</math> hours Ambient temperature : <math>35 \pm 2^{\circ}\text{C}</math> (JIS 60068-2-11/MIL-STD-202 Method 101)</p>	外 観 Appearance	製品機能を損なう 異常なきこと No Damage on function
			接 触 抵 抗 Contact Resistance	40 milliohms MAX.

THIS DOCUMENT CONTAINS INFORMATION THAT IS PROPRIETARY TO MOLEX ELECTRONIC TECHNOLOGIES, LLC AND SHOULD NOT BE USED WITHOUT WRITTEN PERMISSION

REVISION DESCRIPTION	REVISED	<b>MINI-LOCK 2.5 W/B CONNECTOR</b>						
CHANGE NO.	652870							
REVISED BY	MIKEDA01	DATE	2023/03/27	DOC TYPE	DOC TYPE DESCRIPTION	DOC PART	SERIES	
REV APPR BY	AIDA	DATE	2023/05/15	PS	ENGINEERING SPECIFICATION WORD	000	51163	
INITIAL RELEASE				CUSTOMER	DOCUMENT NUMBER	REVISION	SHEET	
INITIAL DRWN	RWATANABE01	DATE	2018/09/07	GENERAL	511630000-PS	H	8 OF 21	
INITIAL APPR	TKANEKO	DATE	2018/09/10					



項 目 Item		条 件 Test Condition	規 格 Requirement	
4-3-10	耐亜硫酸ガス SO <sub>2</sub> Gas	コネクタを嵌合させ、40±2°Cにて50 ±5 ppmの亜硫酸ガス中に24時間放置する。  Mate connectors and expose to the conditions of 50 ±5 ppm SO <sub>2</sub> gas at ambient temperature 40 ±2 °C for 24 hours.	外 観 Appearance	製品機能を損なう異常なきこと No Damage on function
			接 触 抵 抗 Contact Resistance	40 milliohms MAX.
4-3-11	耐アンモニア性 NH <sub>3</sub> Gas	コネクタを嵌合させ、濃度28%のアンモニア水を入れた容器中に40分間放置する。 [1Lに対して25mLの割合] Mate connectors and expose to the conditions of 28% concentration NH <sub>3</sub> solution for 40 minutes. [The ratio is 25 ml per 1 L]	外 観 Appearance	製品機能を損なう異常なきこと No Damage on function
			接 触 抵 抗 Contact Resistance	40 milliohms MAX.

THIS DOCUMENT CONTAINS INFORMATION THAT IS PROPRIETARY TO MOLEX ELECTRONIC TECHNOLOGIES, LLC AND SHOULD NOT BE USED WITHOUT WRITTEN PERMISSION

REVISION DESCRIPTION	REVISED			<b>MINI-LOCK 2.5 W/B CONNECTOR</b>					
CHANGE NO.	652870								
REVISED BY	MIKEDA01	DATE	2023/03/27	DOC TYPE	DOC TYPE DESCRIPTION		DOC PART	SERIES	
REV APPR BY	AIDA	DATE	2023/05/15	PS	ENGINEERING SPECIFICATION WORD		000	51163	
INITIAL RELEASE				CUSTOMER		DOCUMENT NUMBER		REVISION	SHEET
INITIAL DRWN	RWATANABE01	DATE	2018/09/07	GENERAL		<b>511630000-PS</b>		<b>H</b>	9 OF 21
INITIAL APPR	TKANEKO	DATE	2018/09/10						

項目 Item		条件 Test Condition	規格 Requirement	
4-3-12	はんだ付け性 Solderability	<u>スルーホールタイプ</u> <u>Through Hole Type</u> ターミナルまたはピンをフラックスに浸し、端子先端より1.2mm迄、 245±3°Cのはんだに3±0.5秒浸す。 Dip terminal or pin into flux, and immerse the area up to 1.2 mm from the tip of terminal into molten solder pot at 245 ±3 °C for 3 ±0.5 sec.	濡れ性 Solder Wetting	ピンホールや隙間なく浸漬面積の95%以上 95% MIN. of immersed area and there are no voids, pin holes.
		<u>SMTタイプ</u> <u>SMT Type</u> ターミナルまたはピンをフラックスに浸し、製品の基板実装面より0.2mm迄、 245±3°Cのはんだに3±0.5秒浸す。 Dip terminal or pin into flux, and immerse the area up to 0.2 mm from the product mounted surface on PCB into molten solder pot at 245±3 °C for 3±0.5 sec.		
4-3-13	はんだ耐熱性 Resistance to Soldering Heat	<u>スルーホールタイプの場合</u> <u>Soldering bath method for Through Hole Type</u> ターミナルまたはピンを本体取付け基準面より1.2mm迄、260±5°Cのはんだに5±0.5秒浸す。 Dip terminal or pin into immerse the area up to 1.2 mm from the lowest surface of product into molten solder at 260 ±5 °C for 5 ±0.5 sec.	外観 Appearance	端子ガタ、割れ等異常なきこと No Damage
		<u>SMTタイプ 赤外線リフロー時</u> <u>Soldered by IR Reflow Machine for SMT Type</u> 第7項の推奨温度プロファイル条件にてリフローを行う。 Using the reflow profile condition below paragraph 7, the product shall be reflowed.		
		<u>手はんだ時</u> <u>Manual Soldering iron method</u> 350±10°Cのはんだゴテにて最大5秒加熱する。但し、端ピンに異常な加圧のないこと。 Using a manual soldering iron [350±10°C for 5 seconds MAX.], the product shall be heated up. However, do not apply excessive pressure to either the terminals or fitting nails.		

( ) : 参考規格 Reference Standard  
 { } : 参考単位 Reference Unit

THIS DOCUMENT CONTAINS INFORMATION THAT IS PROPRIETARY TO MOLEX ELECTRONIC TECHNOLOGIES, LLC AND SHOULD NOT BE USED WITHOUT WRITTEN PERMISSION

REVISION DESCRIPTION	REVISED	<b>MINI-LOCK 2.5 W/B CONNECTOR</b>						
CHANGE NO.	652870							
REVISED BY	MIKEDA01	DATE	2023/03/27	DOC TYPE	DOC TYPE DESCRIPTION	DOC PART	SERIES	
REV APPR BY	AIDA	DATE	2023/05/15	PS	ENGINEERING SPECIFICATION WORD	000	51163	
INITIAL RELEASE				CUSTOMER	DOCUMENT NUMBER	REVISION	SHEET	
INITIAL DRWN	RWATANABE01	DATE	2018/09/07	GENERAL	<b>511630000-PS</b>	<b>H</b>	10 OF 21	
INITIAL APPR	TKANEKO	DATE	2018/09/10					

## 【5. 外観形状、寸法及び材質 PRODUCT SHAPE, DIMENSIONS AND MATERIALS】

## 5-1. 製品寸法及び材質 Dimensions and materials of product.

図面参照 Refer to the drawing.

## 【6. 挿入力及び抜去力 INSERTION / WITHDRAWAL FORCE】

極数 No. of CKT	単位 UNIT	挿入力（最大値） Insertion (MAX.)			抜去力（最小値） Withdrawal (MIN.)		
		初回 1st	6回目 6th	30回目 30th	初回 1st	6回目 6th	30回目 30th
2	N {kgf}	16.6 { 1.70 }	16.6 { 1.70 }	16.6 { 1.70 }	2.0 { 0.20 }	2.0 { 0.20 }	2.0 { 0.20 }
3	N {kgf}	22.0 { 2.25 }	22.0 { 2.25 }	22.0 { 2.25 }	3.0 { 0.30 }	3.0 { 0.30 }	3.0 { 0.30 }
4	N {kgf}	29.4 { 3.00 }	29.4 { 3.00 }	29.4 { 3.00 }	4.0 { 0.40 }	4.0 { 0.40 }	4.0 { 0.40 }
5	N {kgf}	36.7 { 3.75 }	36.7 { 3.75 }	36.7 { 3.75 }	4.9 { 0.50 }	4.9 { 0.50 }	4.9 { 0.50 }
6	N {kgf}	44.1 { 4.50 }	44.1 { 4.50 }	44.1 { 4.50 }	5.9 { 0.60 }	5.9 { 0.60 }	5.9 { 0.60 }
7	N {kgf}	51.4 { 5.25 }	51.4 { 5.25 }	51.4 { 5.25 }	6.9 { 0.70 }	6.9 { 0.70 }	6.9 { 0.70 }
8	N {kgf}	58.8 { 6.00 }	58.8 { 6.00 }	58.8 { 6.00 }	7.9 { 0.80 }	7.9 { 0.80 }	7.9 { 0.80 }
9	N {kgf}	66.1 { 6.75 }	66.1 { 6.75 }	66.1 { 6.75 }	8.9 { 0.90 }	8.9 { 0.90 }	8.9 { 0.90 }
10	N {kgf}	73.5 { 7.50 }	73.5 { 7.50 }	73.5 { 7.50 }	9.8 { 1.00 }	9.8 { 1.00 }	9.8 { 1.00 }
11	N {kgf}	80.8 { 8.25 }	80.8 { 8.25 }	80.8 { 8.25 }	10.8 { 1.10 }	10.8 { 1.10 }	10.8 { 1.10 }
12	N {kgf}	88.2 { 9.00 }	88.2 { 9.00 }	88.2 { 9.00 }	11.8 { 1.20 }	11.8 { 1.20 }	11.8 { 1.20 }
13	N {kgf}	95.5 { 9.75 }	95.5 { 9.75 }	95.5 { 9.75 }	12.7 { 1.30 }	12.7 { 1.30 }	12.7 { 1.30 }
14	N {kgf}	102.9 { 10.50 }	102.9 { 10.50 }	102.9 { 10.50 }	13.7 { 1.40 }	13.7 { 1.40 }	13.7 { 1.40 }
15	N {kgf}	110.2 { 11.25 }	110.2 { 11.25 }	110.2 { 11.25 }	14.7 { 1.50 }	14.7 { 1.50 }	14.7 { 1.50 }

※ロックを解除して測定 Released the positive lock, and measure.

{ } :参考単位 Reference Unit

THIS DOCUMENT CONTAINS INFORMATION THAT IS PROPRIETARY TO MOLEX ELECTRONIC TECHNOLOGIES, LLC AND SHOULD NOT BE USED WITHOUT WRITTEN PERMISSION

REVISION DESCRIPTION	REVISED	<b>MINI-LOCK 2.5 W/B CONNECTOR</b>						
CHANGE NO.	652870							
REVISED BY	MIKEDA01	DATE	2023/03/27	DOC TYPE	DOC TYPE DESCRIPTION	DOC PART	SERIES	
REV APPR BY	AIDA	DATE	2023/05/15	PS	ENGINEERING SPECIFICATION WORD	000	51163	
INITIAL RELEASE			CUSTOMER		DOCUMENT NUMBER		REVISION	SHEET
INITIAL DRWN	RWATANABE01	DATE	2018/09/07	GENERAL	<b>511630000-PS</b>	<b>H</b>	11 OF 21	
INITIAL APPR	TKANEKO	DATE	2018/09/10					

【7. SMTタイプ リフロー条件 REFLOW CONDITION FOR SMT TYPE】

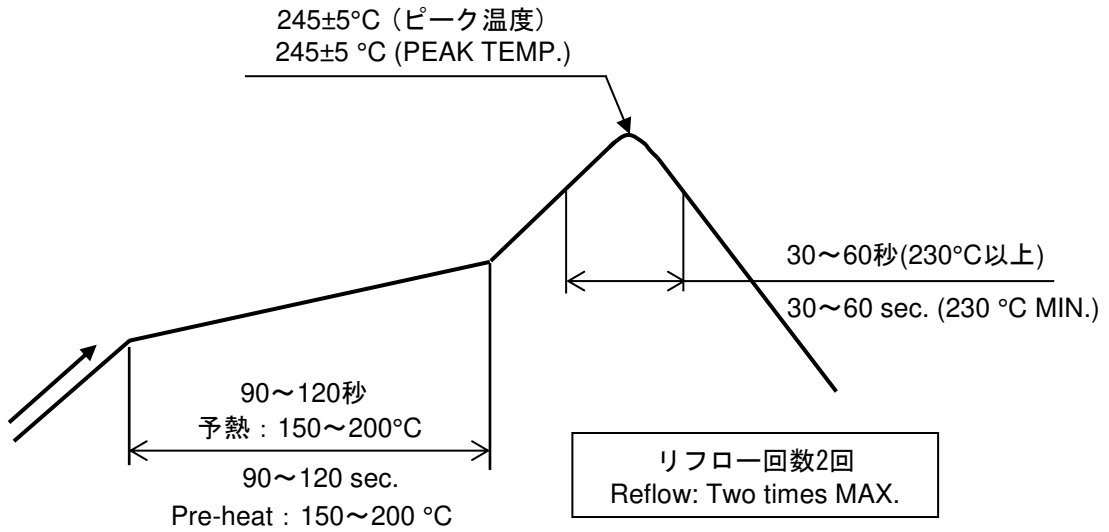

温度条件グラフ  
TEMPERATURE CONDITION GRAPH

(はんだ接合部の基板表面にて測定)  
(Temperature is measured at the soldering area on the surface of PCB)

- 注記 : 本リフロー条件に関しては、リフロー装置及び基板などにより条件が異なりますので  
事前に実装評価(リフロー評価) の御確認を御願ひ致します。  
端子テール部、ネイル部が変色する場合がございますが、はんだ付け性には問題ありません。  
基板背面実装時には、コネクタの落下防止の為、固定する等の措置を御願ひ致します。
- NOTE : Please check the mount condition (reflow soldering condition) by your own devices  
beforehand, because each condition varies by the reflow machine, printed circuit boards (PCB),  
and so on. Although tail of terminal and nail might be discolored, it does not affect solderability.  
When mounting on the back of the board, please take measures such as fixing to prevent the  
connector from falling.

THIS DOCUMENT CONTAINS INFORMATION THAT IS PROPRIETARY TO MOLEX ELECTRONIC TECHNOLOGIES, LLC AND SHOULD NOT BE USED WITHOUT WRITTEN PERMISSION

REVISION DESCRIPTION	REVISED	<b>MINI-LOCK 2.5 W/B CONNECTOR</b>					
CHANGE NO.	652870						
REVISED BY	MIKEDA01	DATE	2023/03/27	DOC TYPE	DOC TYPE DESCRIPTION	DOC PART	SERIES
REV APPR BY	AIDA	DATE	2023/05/15	PS	ENGINEERING SPECIFICATION WORD	000	51163
INITIAL RELEASE				CUSTOMER	DOCUMENT NUMBER	REVISION	SHEET
INITIAL DRWN	RWATANABE01	DATE	2018/09/07	GENERAL	<b>511630000-PS</b>	<b>H</b>	12 OF 21
INITIAL APPR	TKANEKO	DATE	2018/09/10				

【8. 接触抵抗測定箇所 CONTACT RESISTANCE MEASURING POINT】

[Through Hole Type]

接触抵抗 Contact Resistance  
 $m\Omega = V/A$

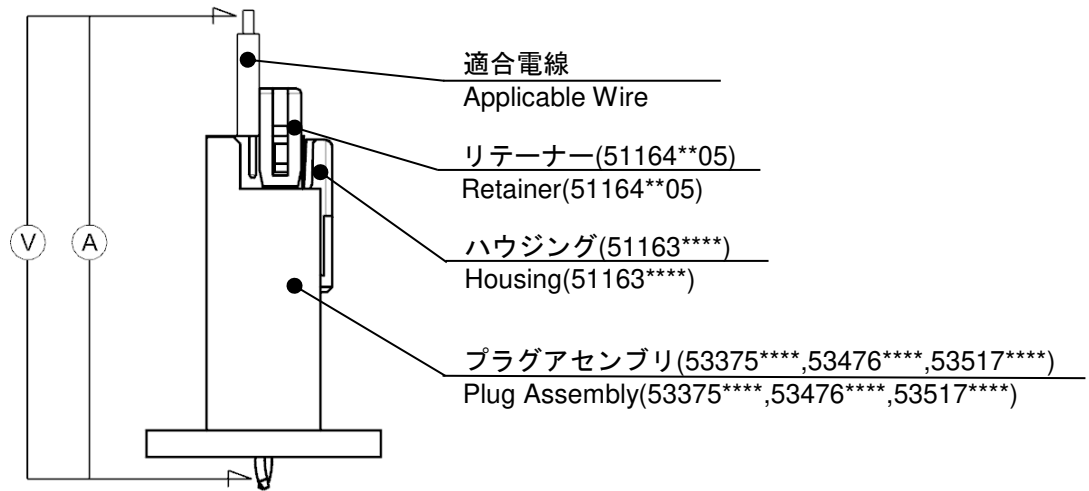

**VERTICAL TYPE**

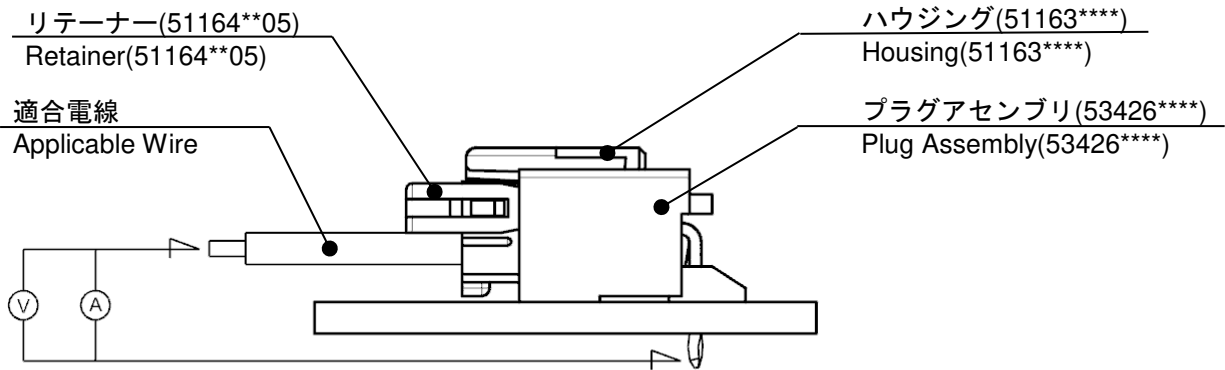

**RIGHT ANGLE TYPE**

THIS DOCUMENT CONTAINS INFORMATION THAT IS PROPRIETARY TO MOLEX ELECTRONIC TECHNOLOGIES, LLC AND SHOULD NOT BE USED WITHOUT WRITTEN PERMISSION

REVISION DESCRIPTION	REVISED	<b>MINI-LOCK 2.5 W/B CONNECTOR</b>					
CHANGE NO.	652870						
REVISED BY	MIKEDA01	DATE	2023/03/27	DOC TYPE	DOC TYPE DESCRIPTION	DOC PART	SERIES
REV APPR BY	AIDA	DATE	2023/05/15	PS	ENGINEERING SPECIFICATION WORD	000	51163
INITIAL RELEASE				CUSTOMER	DOCUMENT NUMBER	REVISION	SHEET
INITIAL DRWN	RWATANABE01	DATE	2018/09/07	GENERAL	<b>511630000-PS</b>	<b>H</b>	13 OF 21
INITIAL APPR	TKANEKO	DATE	2018/09/10				

[SMT Type]

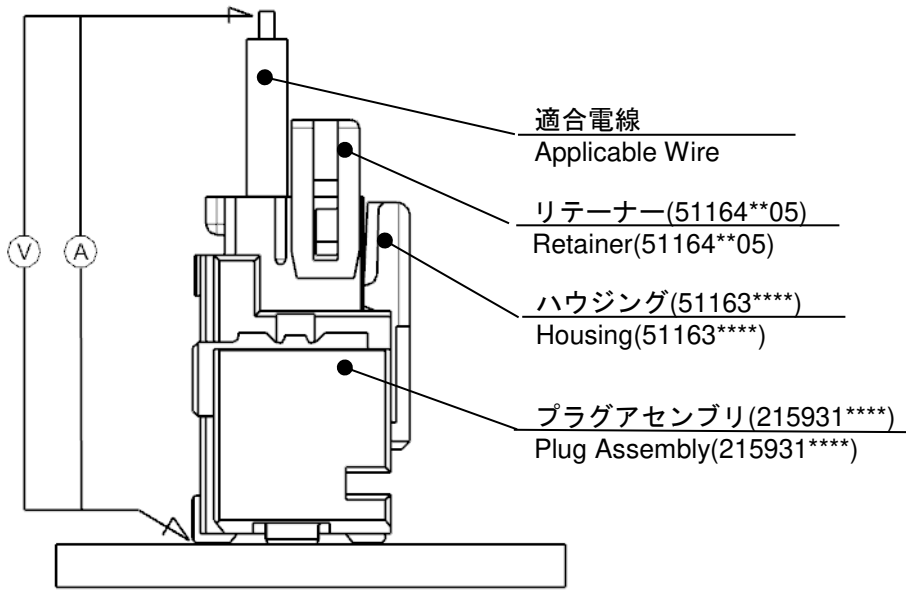

**VERTICAL TYPE**

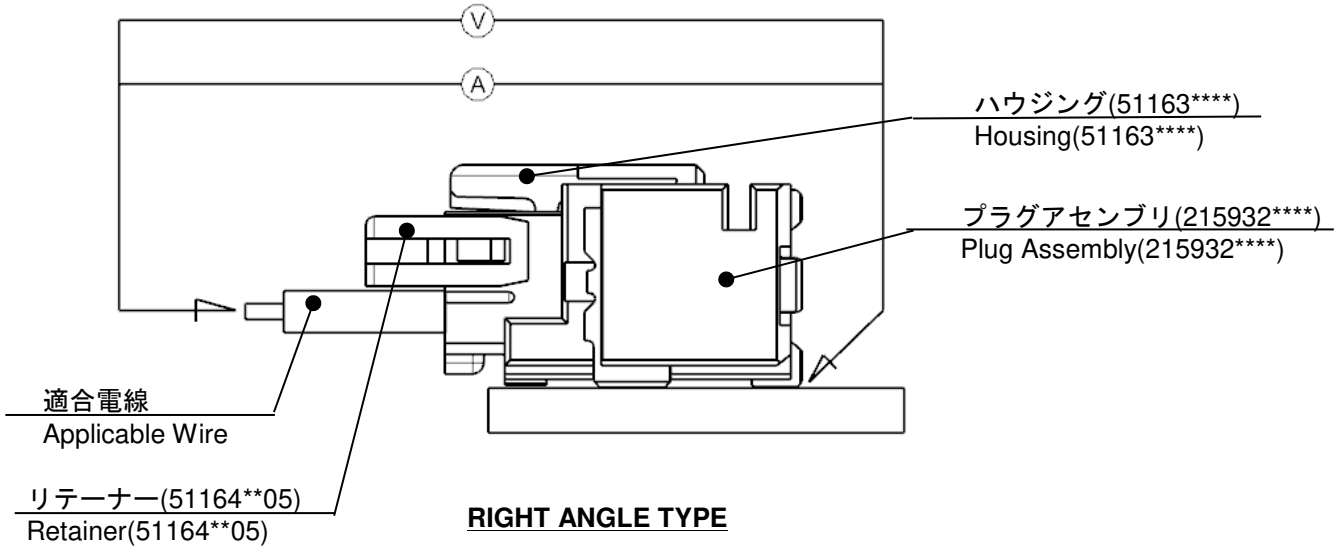

**RIGHT ANGLE TYPE**

THIS DOCUMENT CONTAINS INFORMATION THAT IS PROPRIETARY TO MOLEX ELECTRONIC TECHNOLOGIES, LLC AND SHOULD NOT BE USED WITHOUT WRITTEN PERMISSION

REVISION DESCRIPTION	REVISED	<b>MINI-LOCK 2.5 W/B CONNECTOR</b>							
CHANGE NO.	652870								
REVISED BY	MIKEDA01	DATE	2023/03/27	DOC TYPE	DOC TYPE DESCRIPTION	DOC PART	SERIES		
REV APPR BY	AIDA	DATE	2023/05/15	PS	ENGINEERING SPECIFICATION WORD	000	51163		
INITIAL RELEASE				CUSTOMER		DOCUMENT NUMBER		REVISION	SHEET
INITIAL DRWN	RWATANABE01	DATE	2018/09/07	GENERAL		<b>511630000-PS</b>		<b>H</b>	14 OF 21
INITIAL APPR	TKANEKO	DATE	2018/09/10						

## 【9. 注記 NOTES.】

## &lt;1. 全般&gt;

- 1-1. コネクタの嵌合を取り外す際は、かならずロックを解除して行ってください。  
When connectors are unmated, positive locks shall certainly be released.
- 1-2. 本製品のプラスチック部に黒点、気泡等が確認される場合や色合いが異なる場合（経年変化によるハウジングの変色を含む）が御座いますが、製品性能に影響は御座いません。  
There is no influence in the product performance in case that the black spot or bubble etc. might be appeared on the plastic part of this product and the color shade might be different (including discoloration by aging etc.).
- 1-3. 本製品は錫めっきを使用している為、外観に摺動痕がつく場合が御座いますが、製品性能に影響は御座いません。  
The sliding surface marking might be shown on the appearance because the tin plating is used for the tail and nail, however, there is no influence in the product performance.
- 1-4. 本製品のハウジング及びめっき表面に多少の傷が確認される場合がありますが、製品性能に問題御座いません。  
A few scratches may be seen on the surface of the housing and the plating of this product, however, there is no issue in the product performance.
- 1-5. 本製品のプラスチック部が紫外線により変色する場合がありますが、製品性能には問題御座いません。  
Discoloration of the plastic part of this product can be appeared by the exposure to ultraviolet light, however, there is no issue in the product performance.
- 1-6. 本製品を結露・水濡れが発生する環境でのご使用の場合は、適切な防滴処置をお願い致します。  
結露・水濡れにより、回路間で絶縁不良を起こす可能性が御座います。  
When this product is used at a place where the water exposure could be expected, please provide the appropriate care to avoid the damage from water.  
There is a possibility of causing insulated malfunction between the circuits by condensation and water leakage.
- 1-7. コネクタの性能を損なう恐れがある為、コネクタの洗浄は、行わないでください。  
Please do not conduct any washing process on the connectors because it may damage the functionality.
- 1-8. 本製品をご使用時に取り付けられた電線・プリント基板の共振や、機器の回転構造や可動部分の動作によりコネクタ嵌合部（接点部）が常に動いてしまう状態での御使用は避けてください。  
接触部の摺動磨耗等による 接触不良の原因となります。従って、機器内で電線・プリント基板を固定し、共振を抑える等の処置をお願い致します。  
Please avoid the situation which the contact area of connector always moves around. For example, the contact area is experiencing a constant movement by the sympathetic vibration of wires and PCB, rotating construction of devices, and action of moveable area. This may cause a defect in the conductivity due to the contact area being worn down. Therefore, please fix wires and PCB on the chassis, and reduces sympathetic vibration.

THIS DOCUMENT CONTAINS INFORMATION THAT IS PROPRIETARY TO MOLEX ELECTRONIC TECHNOLOGIES, LLC AND SHOULD NOT BE USED WITHOUT WRITTEN PERMISSION

REVISION DESCRIPTION	REVISED	<b>MINI-LOCK 2.5 W/B CONNECTOR</b>					
CHANGE NO.	652870						
REVISED BY	MIKEDA01	DATE	2023/03/27	DOC TYPE	DOC TYPE DESCRIPTION	DOC PART	SERIES
REV APPR BY	AIDA	DATE	2023/05/15	PS	ENGINEERING SPECIFICATION WORD	000	51163
INITIAL RELEASE				CUSTOMER	DOCUMENT NUMBER	REVISION	SHEET
INITIAL DRWN	RWATANABE01	DATE	2018/09/07	GENERAL	<b>511630000-PS</b>	<b>H</b>	15 OF 21
INITIAL APPR	TKANEKO	DATE	2018/09/10				

- 1-9. コネクタ嵌合状態で基板の持ち運び等コネクタに負荷が掛かる作業は行わないようにしてください。コネクタ破損等の原因となる場合が御座います。  
Please do not apply the extra pressure on the connector. For example, do not carry around the substrate which has mated hanging connector on board. There is a case where it causes the damage of connector.
- 1-10. 嵌合後、コネクタピッチ方向、スパン方向及び回転方向への負荷がかかるような動作またはセットはしないでください。コネクタ破壊やはんだクラックを引き起こします。  
After mated the connectors, please do not allow the PCBs to apply pressure on the connectors in either the pitch direction, the span direction or rotational direction. It may cause damage to the connectors and may crack the soldering.
- 1-11. 本製品及び加工工程品（仕掛品）や加工品（ハーネス等）の梱包及び輸送・保管時にはコネクタに負荷が加わらないようご注意ください。変形、破損などの原因となり、コネクタの性能不良の原因となります。  
Please ensure to prevent from applying any external forces or shock to the connector when connector or the cable assembly in process or cable assembly is under being packaged, or under transportation. This may cause deformation and damage to the connector and may cause a defect in product performance.
- 1-12. 本製品をご使用時には、1PIN当りの定格以上の電流を複数の回路に分岐しての使用は避けてください。  
When using this product, please ensure to follow within its rated current per circuit. Please ensure not to apply the sum of the rated current separated in several circuits to exceed the maximum allowable rated current.
- 1-13. 活電状態の電気回路で、挿入、抜去ができることを前提に作られておりません。スパーク等による危険の発生、性能不良につながりますので、活電状態での挿入、抜去はしないでください。  
This product is not designed for the mating and unmating of the connector under the condition of an active electrical circuit. It may cause a risk of electric spark and the defect in product performance. Please do not conduct the hot plug and hot unplug.
- 1-14. コネクタに適用できる電線は、原則として錫めっきつき付軟銅撚り線です。その他の電線の使用については別途ご確認ください。  
The applicable wire for this connector, in principle, is tin-plated copper stranded wire. Please consult molex and evaluate it in advance when using other kind of wires.
- 1-15. コネクタに外力が加わらないようにクリアランスをあげた筐体構造にしてください。  
Please ensure to keep enough clearance between the connector and chassis of your device in order not to apply pressure on the connector.
- 1-16. 電線の結束はコネクタから45mm以上のところで、電線に加わる力が均一になるようにしてください。ハーネス品で電線一本（又は特定の数本）に力が加わらない様にしてください。  
Please tie the cables at least 45 mm away from the edge of the connector housing and ensure that the forces on all the wires are applied evenly.
- 1-17. 治具等を使用して圧着端子を抜いた場合には、ランスが変形し強度が低下し端子を再装着後の端子保持力が極端に低下します。そのため、圧着端子のリペアの際には新しいハウジングを必ず使用してください。  
When extracting a crimp terminal from the housing by using a jig, it may deform the housing lance, and it causes to reduce the terminal retention force enormously after re-inserting the terminal. Therefore, please ensure to use a new housing after repairing the crimp terminals.

THIS DOCUMENT CONTAINS INFORMATION THAT IS PROPRIETARY TO MOLEX ELECTRONIC TECHNOLOGIES, LLC AND SHOULD NOT BE USED WITHOUT WRITTEN PERMISSION

REVISION DESCRIPTION	REVISED	<b>MINI-LOCK 2.5 W/B CONNECTOR</b>					
CHANGE NO.	652870						
REVISED BY	MIKEDA01	DATE	2023/03/27	DOC TYPE	DOC TYPE DESCRIPTION	DOC PART	SERIES
REV APPR BY	AIDA	DATE	2023/05/15	PS	ENGINEERING SPECIFICATION WORD	000	51163
INITIAL RELEASE				CUSTOMER	DOCUMENT NUMBER	REVISION	SHEET
INITIAL DRWN	RWATANABE01	DATE	2018/09/07	GENERAL	<b>511630000-PS</b>	<b>H</b>	16 OF 21
INITIAL APPR	TKANEKO	DATE	2018/09/10				



- 1-18. ハーネス加工品及びコネクタ嵌合後の電線の引き回しの際、引張りによる力が加わりますと、接点部、結線部（圧着部）やロック部（端子ロック部）が損傷を受け、接触不良の原因となります。  
電線の引回し配線をされる場合、コネクタに無理な外力が加わらないように、電線に緩みを持たせ、余裕を持たせる処置をしてください。  
When positioning cable assembly and cable assembly after mating connectors in the device, it should not have a constant stress or a pulling force applied on it. This phenomenon may damage the contact area, crimping area, or terminal lock area, and it causes the defect in conductivity.  
Therefore, when designing the wire positioning in the device, please ensure that there is enough wire length not to stress on the connector.
- 1-19. 電線はまとめて軽くつかみ、リセプタクルハウジングのロックに指を添え、指の平を用いて、ロック解除用バーを押してロックを完全に解除してから、ゆっくり、軸方向にまっすぐに引き抜いてください。  
また、斜めにこじりながら抜くことは避けてください。コネクタを破損させる恐れが御座います。  
When un-mating connector, please ensure to hold wires all together lightly and release the lock completely by attaching flat part of fingers to the lock and pushing the lock bar. Then, please withdraw the receptacle housing slowly and straightly to the mating axial direction. Please avoid withdrawing diagonally and strongly. This may cause the damage of the connector.
- 1-20. ハウジングのロック部やランス部などの可動部、及び端子を故意に変形させないでください。  
製品性能が満足出来ない原因となります。  
Please do not deliberately deform the movable portion (the lock area and lance of receptacle housing) and terminals. It would lead to product failure.
- 1-21. はんだ実装部の未はんだは、ターミナル脱落、ピン間ショート、ターミナル座屈、またコネクタ基板からの外れが懸念されます。従って全てのターミナルテール部及び、ネイル部にはんだ付けを行ってください。  
Please ensure to solder all the terminal tails and fitting nails on the PCB. When you leave any soldering area open, it may cause the short circuit between pins, terminal buckling or connector's coming off the PCB.
- 1-22. 実装機によってコネクタに負荷が加わると変形、破損する場合がありますので事前にご確認ください。  
Please evaluate the connector on your mounter in advance. When the mounter applies the extra pressure on the connector, it may cause the deformation or damage of connector.
- 1-23. 基板実装前後に端子及びネイルに触らないでください。  
Please do not directly touch the terminal and fitting nail area before and after mounting the connector on the PCB.
- 1-24. 基板実装後に基板を直接積み重ねない様に注意してください。  
Please do not stack the PCB directly after mounted the connectors on it.
- 1-25. 実装後において手はんだコテによるリペアを行なう際は、必ず仕様書掲載の条件以内で行なってください。  
条件を超えて実施した場合、端子の抜け、接点ギャップの変化、モールドの変形、熔融等が原因により破損の原因になります。  
Please ensure to conduct the manual soldering under the condition of the product specifications when repairing by manual soldering iron. In the case of practicing beyond the soldering condition, it may cause terminal fallout issue, the contact gap change issue, and the deformation/dissolution of the mold.
- 1-26. はんだコテによる手修正を行なう際、過度のはんだやフラックスを使用しないでください。はんだ上がりやフラックス上がりにより接触、機能不良に至る場合が御座います。  
When conducting manual repairing by using a soldering iron, please do not use more solder and flux than needed. This may cause a solder wicking and flux wicking issues, and it will eventually lead to a contact defect and functional issues.

THIS DOCUMENT CONTAINS INFORMATION THAT IS PROPRIETARY TO MOLEX ELECTRONIC TECHNOLOGIES, LLC AND SHOULD NOT BE USED WITHOUT WRITTEN PERMISSION

REVISION DESCRIPTION	REVISED	<b>MINI-LOCK 2.5 W/B CONNECTOR</b>						
CHANGE NO.	652870							
REVISED BY	MIKEDA01	DATE	2023/03/27	DOC TYPE	DOC TYPE DESCRIPTION	DOC PART	SERIES	
REV APPR BY	AIDA	DATE	2023/05/15	PS	ENGINEERING SPECIFICATION WORD	000	51163	
INITIAL RELEASE				CUSTOMER	DOCUMENT NUMBER	REVISION	SHEET	
INITIAL DRWN	RWATANABE01	DATE	2018/09/07	GENERAL	<b>511630000-PS</b>	<b>H</b>	17 OF 21	
INITIAL APPR	TKANEKO	DATE	2018/09/10					

- 1-27. コネクタのみで基板を支えることは避け、コネクタ以外での基板固定対策を行ってください。  
Please do not use the connector alone to provide mechanical support for the PCB.  
Please ensure that PCB is supported by a fixed structure on the chassis except the connector.
  
- 1-28. 弊社の推奨基板パターン寸法を変更して設計を行なう際は、致命的な不良の原因にもなりますので  
あらかじめご相談ください。  
In the case of changing molex recommended board pattern size on your PCB, please contact molex in  
advance because it may cause a fatal defect.
  
- 1-29. 本品の一般性能確認はガラスエポキシ基板にて実施していますので、フレキシブル基板等の特殊な基板へ  
実装してご使用の際は、別途ご相談願います。  
Please contact Molex surely when using a special PCB or FPC (flexible printed circuit), because we valuated  
connector by using Glass epoxy PCB based on our product specification.
  
- 1-30. 嵌合は極力嵌合軸に沿って平行に行ってください。その際、ハウジングとプラグの外壁同士を合せる様に位  
置決めした後に押し込み、コネクタ同士が突き当たる（完全嵌合位置）まで真っ直ぐ押し込んでください。  
斜めの嵌合になる場合は10°以下の角度でハウジングとプラグの外壁同士を軽く当て、位置決めした後に嵌  
合してください。尚、コネクタ同士を過度に傾けた状態で嵌合を行いますと、ハウジングが破壊する恐れが  
有りますのでこのような嵌合はお避けください。  
Please mate the connector in parallel with the mating axis as much as possible. At this time, after positioning  
and facing each external wall of both receptacle and plug housing, push the connector to mate straight until  
both plug and receptacle housings strike each other. (This is the complete connector mating position.). In the  
case of diagonal mating, position and face lightly each external wall of both receptacle and plug housings  
less than angle of 10 °, and then push to mate. When mating connector in the diagonal angle excessively, it  
may damage the connector.
  
- 1-31. 本製品のリセプタクルハウジング材料はポリアミドを使用しており、吸水状態によって挿抜力・挿入感が変  
化します。過度な吸水により挿入時に嵌合相手と若干干渉する場合や、クリック感が弱くなる場合がありま  
すが、製品性能、機能には問題ございません。  
Because the receptacle housing material of this product is using polyamide, the water absorption status of  
the housing material might influence the insertion force / withdrawal force or feeling of insertion. Though  
its excessive water absorption status may cause to interfere with insertion a bit or to weaken the lock click  
feeling when mating, it does not damage the product's performance and functions.

THIS DOCUMENT CONTAINS INFORMATION THAT IS PROPRIETARY TO MOLEX ELECTRONIC TECHNOLOGIES, LLC AND SHOULD NOT BE USED WITHOUT WRITTEN PERMISSION

REVISION DESCRIPTION	REVISED			<b>MINI-LOCK 2.5 W/B CONNECTOR</b>					
CHANGE NO.	652870								
REVISED BY	MIKEDA01	DATE	2023/03/27	DOC TYPE	DOC TYPE DESCRIPTION		DOC PART	SERIES	
REV APPR BY	AIDA	DATE	2023/05/15	PS	ENGINEERING SPECIFICATION WORD		000	51163	
INITIAL RELEASE				CUSTOMER		DOCUMENT NUMBER		REVISION	SHEET
INITIAL DRWN	RWATANABE01	DATE	2018/09/07	GENERAL		<b>511630000-PS</b>		<b>H</b>	18 OF 21
INITIAL APPR	TKANEKO	DATE	2018/09/10						

1-32. ハウジング（製品番号51163\*\*\*\*）にリテーナー（製品番号51164\*\*05）を挿入する際、図1に示した方向からリテーナー先端が挿入済みの端子に突き当たるまで挿入してください。  
 又、挿入後軽く電線を引張って端子が抜け出さないか確認ください。  
 When inserting the retainer (51164\*\*05) into the housing (51163\*\*\*\*), please ensure that the retainer is inserted completely, and the tip of retainer surely touches the inserted terminal as showing in Fig.1.  
 Also, please pull the wire lightly after inserting the retainer to ensure that the terminals are fully inserted and will not be pulled out.

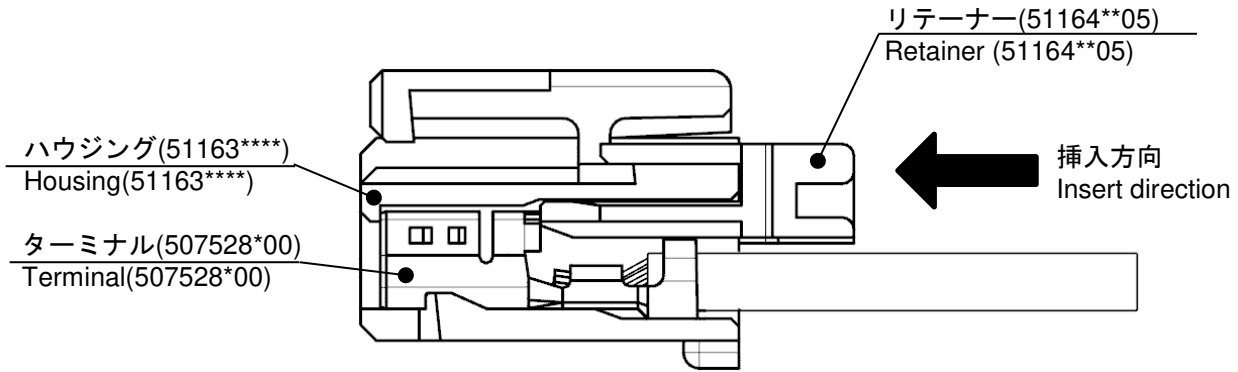

**図1**  
**Fig.1**

THIS DOCUMENT CONTAINS INFORMATION THAT IS PROPRIETARY TO MOLEX ELECTRONIC TECHNOLOGIES, LLC AND SHOULD NOT BE USED WITHOUT WRITTEN PERMISSION

REVISION DESCRIPTION	REVISED	<b>MINI-LOCK 2.5 W/B CONNECTOR</b>					
CHANGE NO.	652870						
REVISED BY	MIKEDA01	DATE	2023/03/27	DOC TYPE	DOC TYPE DESCRIPTION	DOC PART	SERIES
REV APPR BY	AIDA	DATE	2023/05/15	PS	ENGINEERING SPECIFICATION WORD	000	51163
INITIAL RELEASE				CUSTOMER	DOCUMENT NUMBER	REVISION	SHEET
INITIAL DRWN	RWATANABE01	DATE	2018/09/07	GENERAL	<b>511630000-PS</b>	<b>H</b>	19 OF 21
INITIAL APPR	TKANEKO	DATE	2018/09/10				

<2. W/B Through Hole Type>

2-1. コネクタを基板に対して垂直に真っ直ぐ挿入してください。斜めにしたりコジリを加えたりしないでください。

※コネクタを保持する際にはコンタクトに触れることの無い様に御注意ください。

※コネクタを基板に対して垂直に保持した状態で真っ直ぐに基板穴へソルダーテールを挿入してください。

※基板穴とソルダーテールがずれる方向や斜めに傾く様な力を加えないでください。

※無理に斜め挿入を行った場合、ピンの変形、抜けが生じ、コネクタが破損する恐れがあります

Insert the connector solder tails into the PCB straight. Do not insert diagonally or squeeze the connector into PCB.

※When touching the connector, ensure not to touch the contacts.

※Insert the solder tails vertically against the PCB.

※Do not apply forces in such directions that would damage the solder tails.

※In case you push the solder tails in such directions, the pin deformations and pin fallout would occur and may damage the connector.

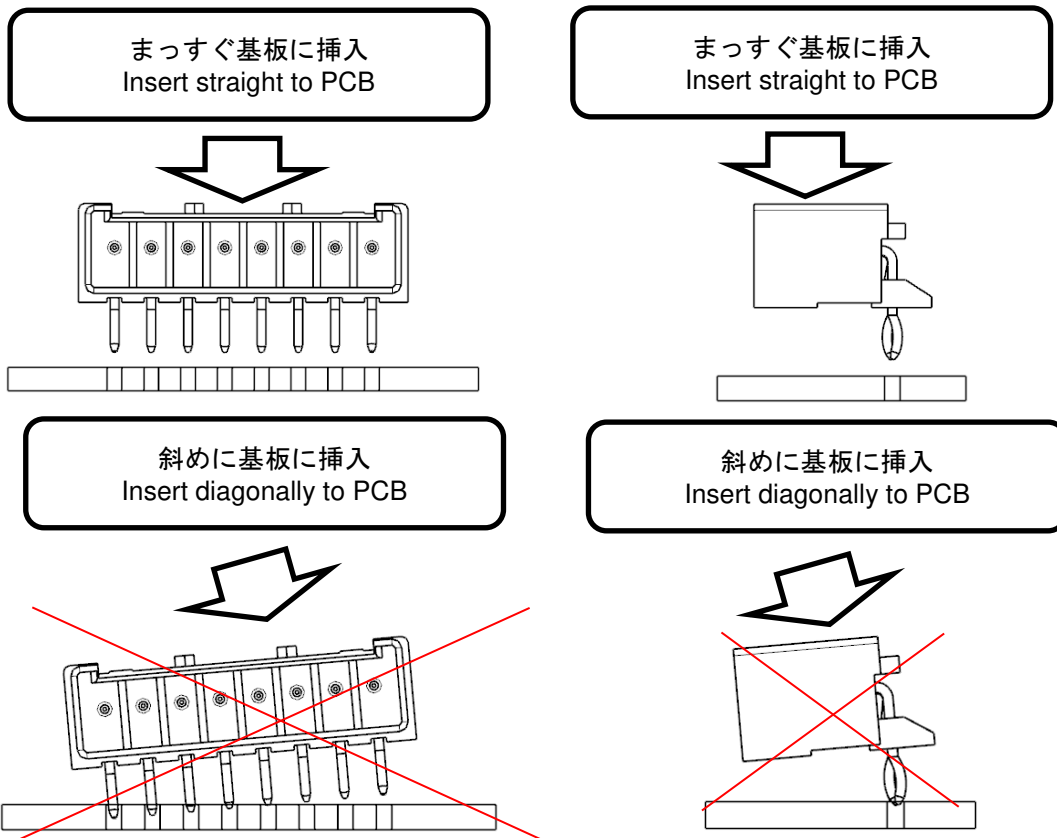

2-2. プラグアセンブリ（製品番号53517\*\*\*\*）のポッティング処理を行う場合、ご使用のポッティング材料や使用環境にて事前に評価を行いご確認ください。

When conducting potting treatment for plug assembly(53517\*\*\*\*), please evaluate your own potting material and condition beforehand.

2-3. プラグアセンブリ（製品番号53517\*\*\*\*）はポッティング高さを2mmから6mmと想定していますが、ご使用のポッティング材料にて嵌合部への吸い上がり、流れ込みがなく挿抜性に影響がないことをご確認ください。 Plug assembly(53517\*\*\*\*) is supposed the potting height is approximately 2 mm ~ 6 mm, however, it could change the proper height depending on the potting material. Please check the wicking or inflow to connector mating area, and ensure that there is no influence on insertion/extraction of the connector.

THIS DOCUMENT CONTAINS INFORMATION THAT IS PROPRIETARY TO MOLEX ELECTRONIC TECHNOLOGIES, LLC AND SHOULD NOT BE USED WITHOUT WRITTEN PERMISSION

REVISION DESCRIPTION		REVISED		<b>MINI-LOCK 2.5 W/B CONNECTOR</b>				
CHANGE NO.		652870						
REVISED BY	MIKEDA01	DATE	2023/03/27	DOC TYPE	DOC TYPE DESCRIPTION	DOC PART	SERIES	
REV APPR BY	AIDA	DATE	2023/05/15	PS	ENGINEERING SPECIFICATION WORD	000	51163	
INITIAL RELEASE				CUSTOMER	DOCUMENT NUMBER	REVISION	SHEET	
INITIAL DRWN	RWATANABE01	DATE	2018/09/07	GENERAL	<b>511630000-PS</b>	<b>H</b>	20 OF 21	
INITIAL APPR	TKANEKO	DATE	2018/09/10					

<3. W/B SMT Type>

- 3-1. リフロー条件によっては端子めっき部にヨリ等が発生する場合がありますが、製品性能には影響ありません。  
There is no influence in the product performance though the twist appearance in the terminal plating area might be generated by some reflow conditions.
- 3-2. リフロー条件によっては樹脂部に変色が発生する場合がありますが、製品性能には影響ありません。  
There is no influence in the product performance though the discoloration in the resin area might be seen by some reflow conditions.
- 3-3. リフロー後、はんだ付け部に変色が見られることがありますが、製品性能に影響はありません。  
There is no influence in the product performance though the discoloration in the soldering area might be seen after reflow.
- 3-4. 本製品は赤外線リフローでの実装を想定しています。N<sub>2</sub>リフローで実装した場合、リフロー後、はんだ上がりを生じる恐れがあります。N<sub>2</sub>リフローでの実装をお考えの場合、別途評価が必要になります。  
This product is designed for using IR (Infrared) reflow machine. When using Nitrogen reflow machine, it might generate the solder wicking issue. Please evaluate the mounting condition (reflow soldering condition) beforehand when using Nitrogen reflow machine.  
The mounting conditions may change due to the soldering temperature, soldering paste, IR reflow machine, Nitrogen reflow machine, and the type of PCB. The different mounting conditions may influence in the product performance.
- 3-5. 弊社評価では厚さ0.15mm、開口率100%のメタルマスクを使用しています。  
The stencil (thickness 0.15 mm / aperture ratio 100 %) is used in this product specification evaluation.
- 3-6. 実装性能（平坦度）は、実装基板の反りの影響を含まないものと致します。基板の反りはコネクタ両端部を基準とし、コネクタ中央部にて 0.02mm以下としてください。  
The connector mounting specification for coplanarity does not include the influence of the PCB warpage. The warpage of the PCB should be a less than 0.02 mm at the center of connector when setting both edges of connector as the datum.
- 3-7. 本製品の平坦度については、実装前での保証のみであり、実装中および実装後での平坦度については、保証の限りではありません。  
The coplanarity of this product is assured only before mounting/reflowing condition. There is no product guarantee in terms of coplanarity during and after mounting/reflowing.

THIS DOCUMENT CONTAINS INFORMATION THAT IS PROPRIETARY TO MOLEX ELECTRONIC TECHNOLOGIES, LLC AND SHOULD NOT BE USED WITHOUT WRITTEN PERMISSION

REVISION DESCRIPTION	REVISED			<b>MINI-LOCK 2.5 W/B CONNECTOR</b>			
CHANGE NO.	652870						
REVISED BY	MIKEDA01	DATE	2023/03/27	DOC TYPE	DOC TYPE DESCRIPTION	DOC PART	SERIES
REV APPR BY	AIDA	DATE	2023/05/15	PS	ENGINEERING SPECIFICATION WORD	000	51163
INITIAL RELEASE				CUSTOMER	DOCUMENT NUMBER	REVISION	SHEET
INITIAL DRWN	RWATANABE01	DATE	2018/09/07	GENERAL	<b>511630000-PS</b>	<b>H</b>	21 OF 21
INITIAL APPR	TKANEKO	DATE	2018/09/10				