



ON Semiconductor®

<http://onsemi.com>

LV8771VH

Bi-CMOS LSI

PWM Constant-Current Control Stepping Motor Driver

Overview

The LV8771VH is a PWM current control stepping motor driver. It is ideally suited for driving stepping motors used in office equipment and amusement applications.

Features

- 1 channel PWM current control stepping motor driver.
- I_O max = 1.5A
- Output on-resistance (High side : 0.6Ω ; Low side : 0.4Ω ; total : 1.0Ω ; $T_a = 25^\circ\text{C}$, $I_O = 1.5\text{A}$).
- Micro step mode can be set to full-step, half-step (full torque), half-step, and quarter-step mode.
- Built-in thermal shutdown circuit.
- No control power supply necessary.

Specifications

Absolute Maximum Ratings at $T_a = 25^\circ\text{C}$

Parameter	Symbol	Conditions	Ratings	Unit
Supply voltage	V_M max		36	V
Output peak current	I_O peak	$t \leq 10\text{ms}$, ON-duty $\leq 20\%$	1.75	A
Output current	I_O max		1.5	A
Allowable power dissipation	P_d max	*	3.0	W
Logic input voltage	V_{IN} max		-0.3 to +6	V
VREF input voltage	VREF max		-0.3 to +6	V
Operating temperature	T_{opr}		-20 to +85	$^\circ\text{C}$
Storage temperature	T_{stg}		-55 to +150	$^\circ\text{C}$

* Specified circuit board : 90.0mm×90.0mm×1.6mm, glass epoxy board.

Caution 1) Absolute maximum ratings represent the value which cannot be exceeded for any length of time.

Caution 2) Even when the device is used within the range of absolute maximum ratings, as a result of continuous usage under high temperature, high current, high voltage, or drastic temperature change, the reliability of the IC may be degraded. Please contact us for the further details.

Stresses exceeding Maximum Ratings may damage the device. Maximum Ratings are stress ratings only. Functional operation above the Recommended Operating Conditions is not implied. Extended exposure to stresses above the Recommended Operating Conditions may affect device reliability.

LV8771VH

Recommendation Operating Conditions at Ta = 25°C

Parameter	Symbol	Conditions	Ratings	Unit
Supply voltage range	VM		9 to 32	V
Logic input voltage	V _{IN}		0 to 5.5	V
VREF input voltage range	VREF		0 to 3	V

Electrical Characteristics at Ta = 25°C, VM = 24V, VREF = 1.5V

Parameter	Symbol	Conditions	Ratings			Unit
			min	typ	max	
Standby mode current drain	IMstn	ST = "L"		100	150	μA
Current drain	IM	ST = "H", I01 = I11 = I02 = I12 = "L", with no load		2	3	mA
VREG5 output voltage	Vreg5	Ireg5 = -1mA	4.7	5	5.3	V
Thermal shutdown temperature	TSD	Design guarantee	150	180	210	°C
Thermal hysteresis width	ΔTSD	Design guarantee		40		°C
Motor driver						
Output on resistance	Ron _u	I _O = 1.5A, Upper-side on resistance		0.6	0.78	Ω
	Ron _d	I _O = 1.5A, Lower-side on resistance		0.4	0.52	Ω
Output leakage current	I _O leak	V _M = 36V			50	μA
Diode forward voltage	VD			1.1	1.4	V
Logic high-level input voltage	V _{INH}		2.0			V
Logic low-level input voltage	V _{INL}				0.8	V
Logic pin input current	I _{INL}	V _{IN} = 0.8V	4	8	12	μA
	I _{INH}	V _{IN} = 5V	30	50	70	μA
Current setting comparator threshold voltage	Vtdac11	I01(02) = "H", I11(12) = "H"	0.29	0.30	0.31	V
	Vtdac01	I01(02) = "L", I11(12) = "H"	0.20	0.21	0.22	V
	Vtdac10	I01(02) = "H", I11(12) = "L"	0.11	0.12	0.13	V
Chopping frequency	Fchop1	FC = "L"	24.8	31.0	37.2	kHz
	Fchop2	FC = "H"	49.6	62.0	74.4	kHz
VREF pin input current	Iref	VREF = 1.5V	-0.5			μA
Charge pump						
VG output voltage	VG		28	28.7	29.8	V
Rise time	t _{ONG}	VG = 0.1μF		200	500	μS
Oscillator frequency	Fosc		100	125	150	kHz

Package Dimensions

unit : mm (typ)

3222A

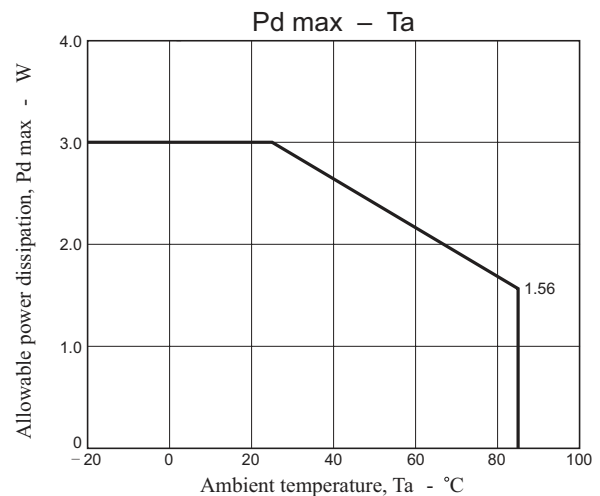
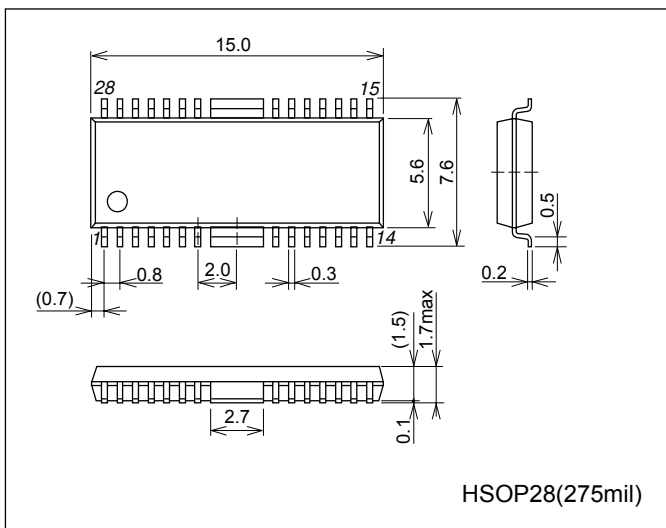

LV8771VH

Block Diagram

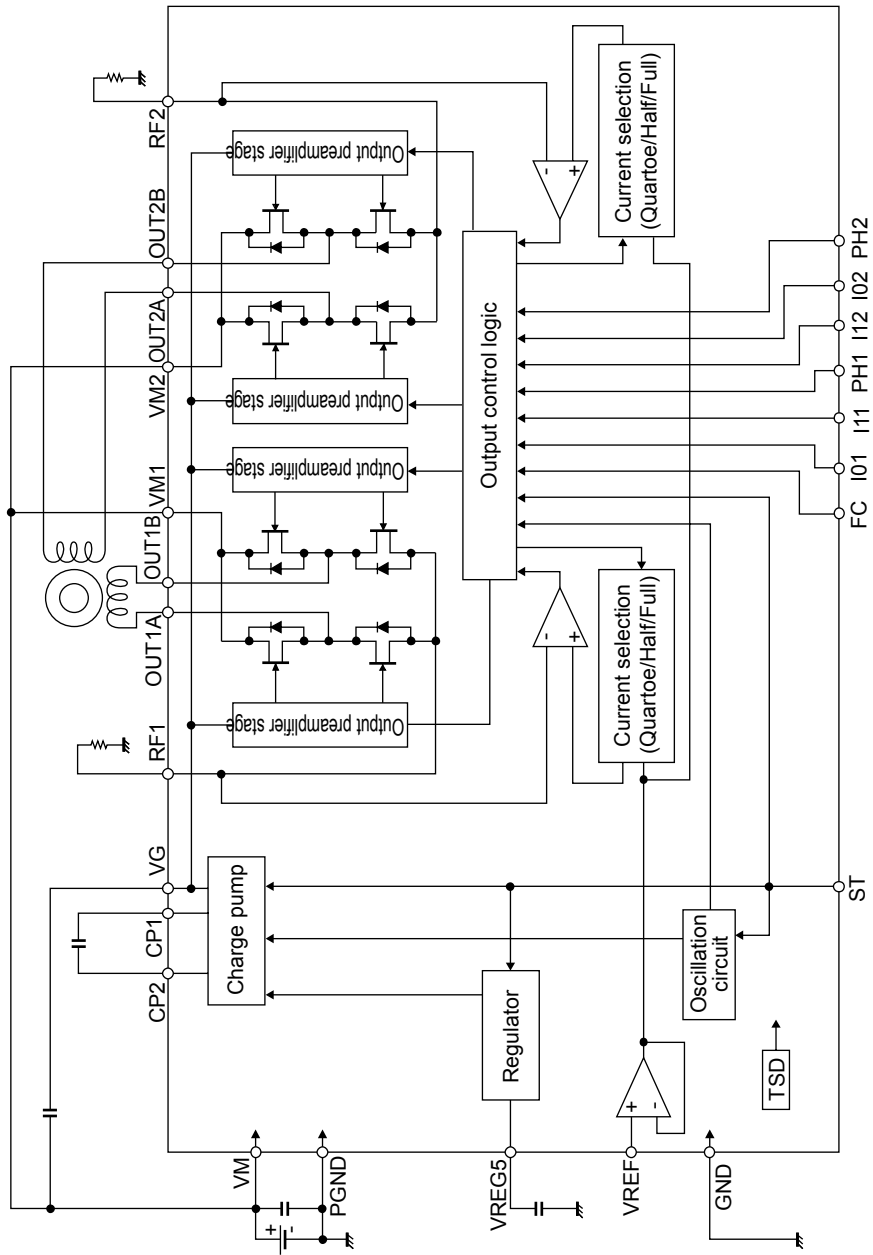

LV8771VH

Pin Assignment

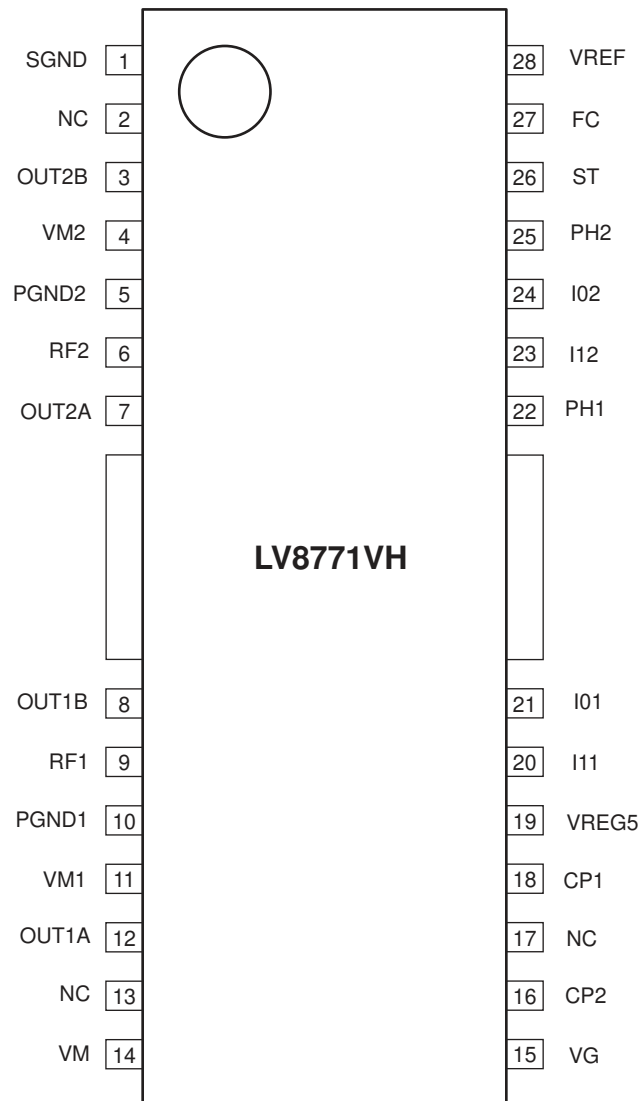

Top view

LV8771VH

Pin Functions

Pin No.	Pin Name	Pin Function	Equivalent Circuit
22 21 20 25 24 23 27	PH1 I01 I11 PH2 I02 I12 FC	Channel 1 forward/reverse rotation pin. Channel 1 output control input pin . Channel 1 output control input pin . Channel 2 forward/reverse rotation pin. Channel 2 output control input pin . Channel 2 output control input pin . Chopping frequency switching pin.	
26	ST	Chip enable pin.	
8 9 10 11 12 3 4 5 6 7	OUT1B RF1 PGND1 VM1 OUT1A OUT2B VM2 PGND2 RF2 OUT2A	Channel 1 OUTB output pin. Channel 1 current-sense resistor connection pin. Power system ground pin 1. Channel 1 motor power supply connection pin. Channel 1 OUTA output pin. Channel 2 OUTB output pin. Channel 2 current-sense resistor connection pin. Power system ground pin 2. Channel 2 motor power supply connection pin. Channel 2 OUTA output pin.	
2, 13 , 17	NC	No Connection (No internal connection to the IC)	

Continued on next page.

LV8771VH

Continued from preceding page.

Pin No.	Pin Name	Pin Function	Equivalent Circuit
15 14 16 18	VG VM CP2 CP1	Charge pump capacitor connection pin. Motor power supply connection pin. Charge pump capacitor connection pin. Charge pump capacitor connection pin.	
19	VREG5	Internal power supply capacitor connection pin.	
28	VREF	Constant current control reference voltage input pin.	

Description of operation

Input Pin Function

The function to prevent including the turn from the input to the power supply is built into each logic pin. Therefore, the current turns to the power supply even if power supply (VM) is turned off with the voltage impressed to the input pin and there is not crowding.

(1) Chip enable function

This IC is switched between standby and operating mode by setting the ST pin. In standby mode, the IC is set to power-save mode and all logic is reset. In addition, the internal regulator circuit and charge pump circuit do not operate in standby mode.

ST	Mode	Internal regulator	Charge pump
Low or Open	Standby mode	Standby	Standby
High	Operating mode	Operating	Operating

(2) Output control logic

I01(02)	I11(12)	Output current (I _O)
Low	Low	0
High	Low	$I_O = ((VREF / 5) / RF) \times 40\%$
Low	High	$I_O = ((VREF / 5) / RF) \times 70\%$
High	High	$I_O = (VREF / 5) / RF$

PH1(2)	Current direction
Low	OUTB → OUTA
High	OUTA → OUTB

(3) Setting constant-current control reference current

This IC is designed to automatically exercise PWM constant-current chopping control for the motor current by setting the output current. Based on the voltage input to the VREF pin and the resistance connected between RF and GND, the output current that is subject to the constant-current control is set using the calculation formula below:

$$I_{OUT} = (VREF / 5) / RF \text{ resistance}$$

* The above setting is the output current at I01(02) = High, I11(12) = Low.

(Example) When VREF = 1.5V, I01(02) = High, I11(12) = Low and RF1(2) resistance is 0.5Ω, the setting current is shown below.

$$I_{OUT} = (1.5V / 5) / 0.5\Omega = 0.6A$$

(4) Chopping frequency control logic

FC	Chopping frequency
Low	31kHz
High	62kHz

(5) Blanking period

If, when exercising PWM constant-current chopping control over the motor current, the mode is switched from decay to charge, the recovery current of the parasitic diode may flow to the current sensing resistance, causing noise to be carried on the current sensing resistance pin, and this may result in erroneous detection. To prevent this erroneous detection, a blanking period is provided to prevent the noise occurring during mode switching from being received. During this period, the mode is not switched from charge to decay even if noise is carried on the current sensing resistance pin.

The blanking time is fixed at approximately 1μs.

(6) Current control operation specification

(Sine wave increasing direction)

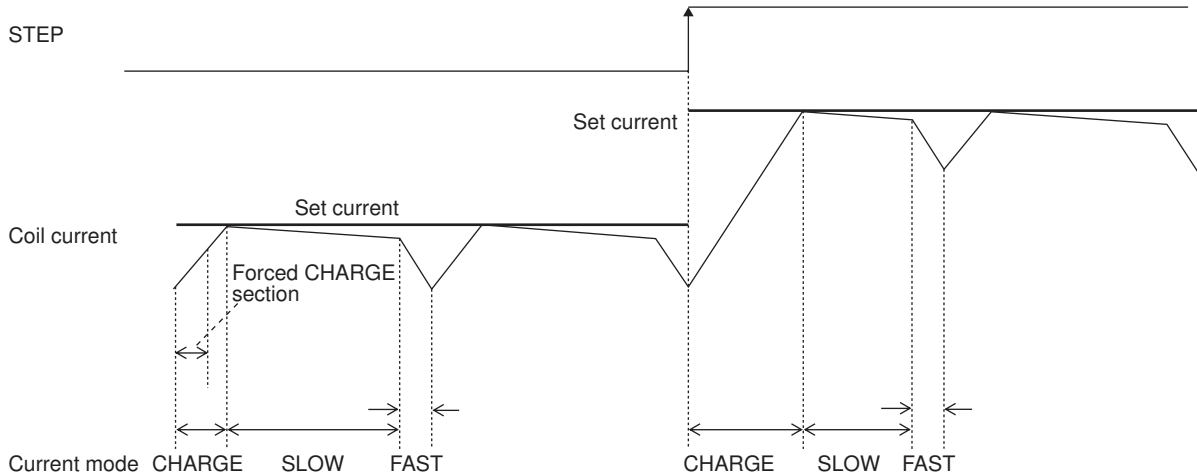

(Sine wave decreasing direction)

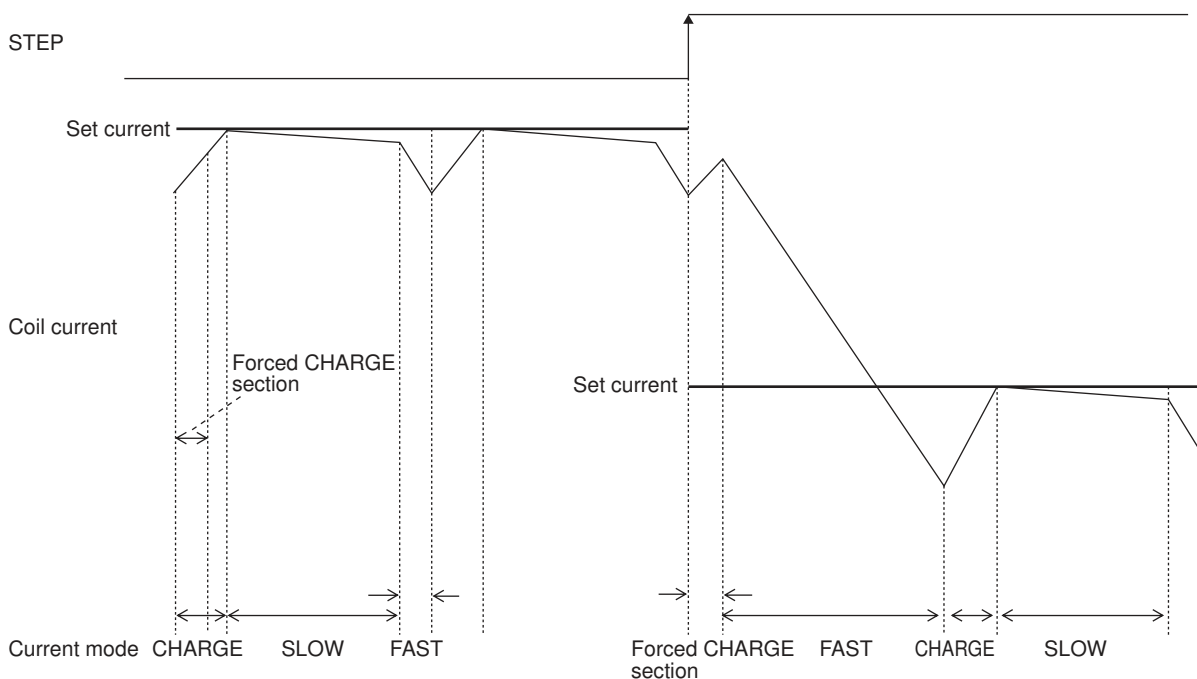

In each current mode, the operation sequence is as described below :

- At rise of chopping frequency, the CHARGE mode begins. (In the time defined as the “blanking time,” the CHARGE mode is forced regardless of the magnitude of the coil current (ICOIL) and set current (IREF).)
- The coil current (ICOIL) and set current (IREF) are compared in this blanking time.

When $(ICOIL < IREF)$ state exists ;

The CHARGE mode up to $ICOIL \geq IREF$, then followed by changeover to the SLOW DECAy mode, and finally by the FAST DECAy mode for approximately $1\mu s$.

When $(ICOIL < IREF)$ state does not exist ;

The FAST DECAy mode begins. The coil current is attenuated in the FAST DECAy mode till one cycle of chopping is over.

Above operations are repeated. Normally, the SLOW (+FAST) DECAy mode continues in the sine wave increasing direction, then entering the FAST DECAy mode till the current is attenuated to the set level and followed by the SLOW DECAy mode.

LV8771VH

(7) Typical current waveform in each excitation mode

Full step (CW mode)

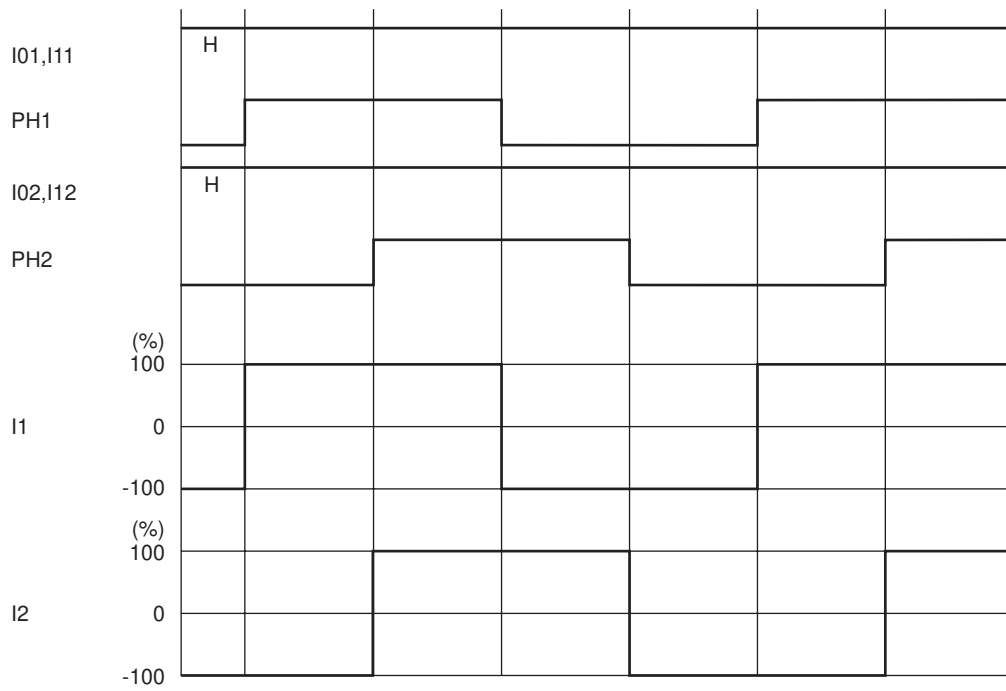

Half step full torque (CW mode)

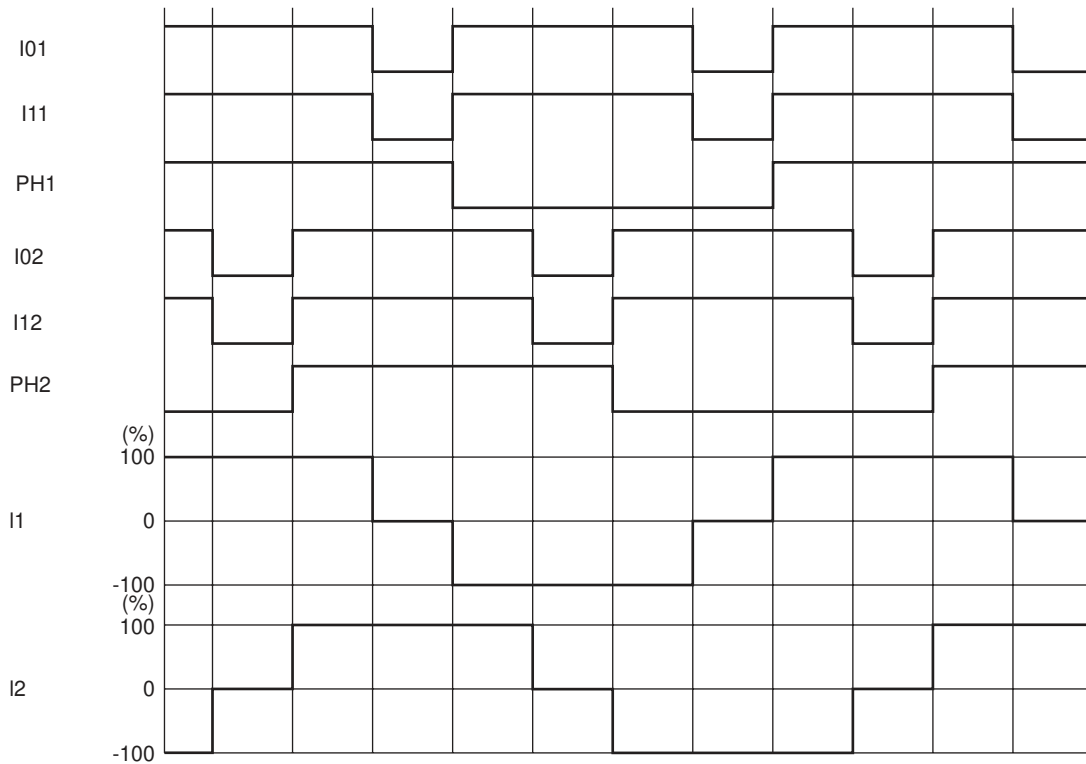

LV8771VH

Half step (CW mode)

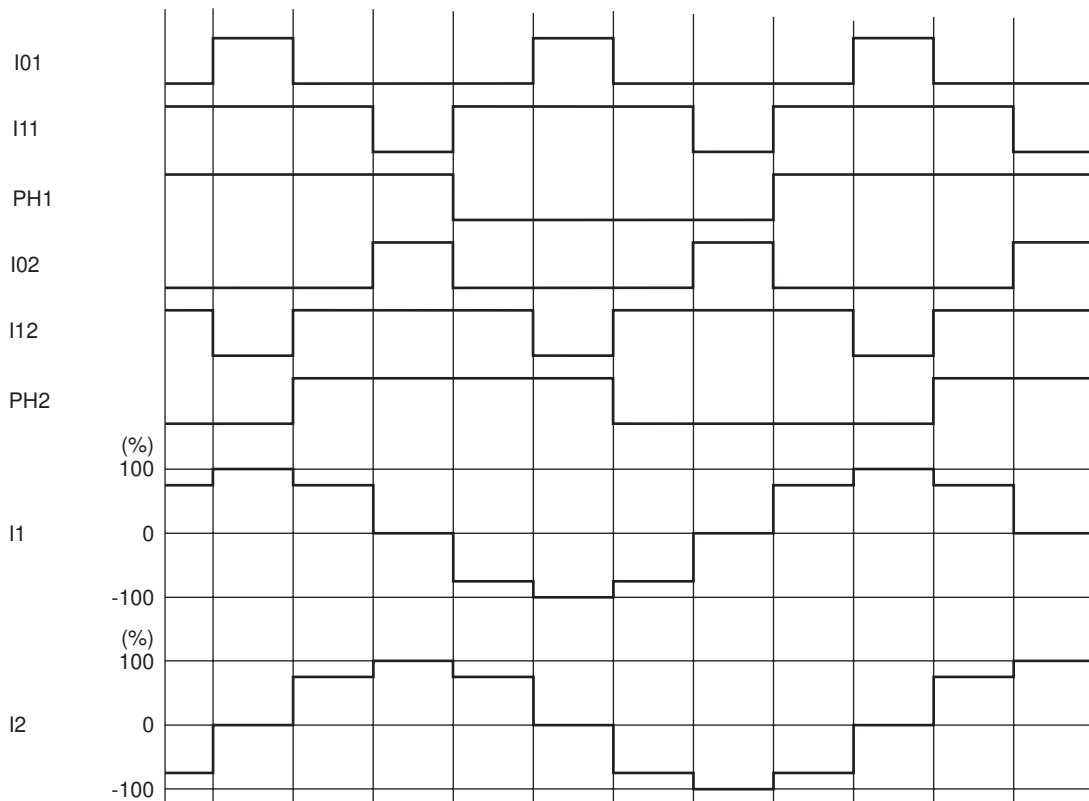

Quarter step (CW mode)

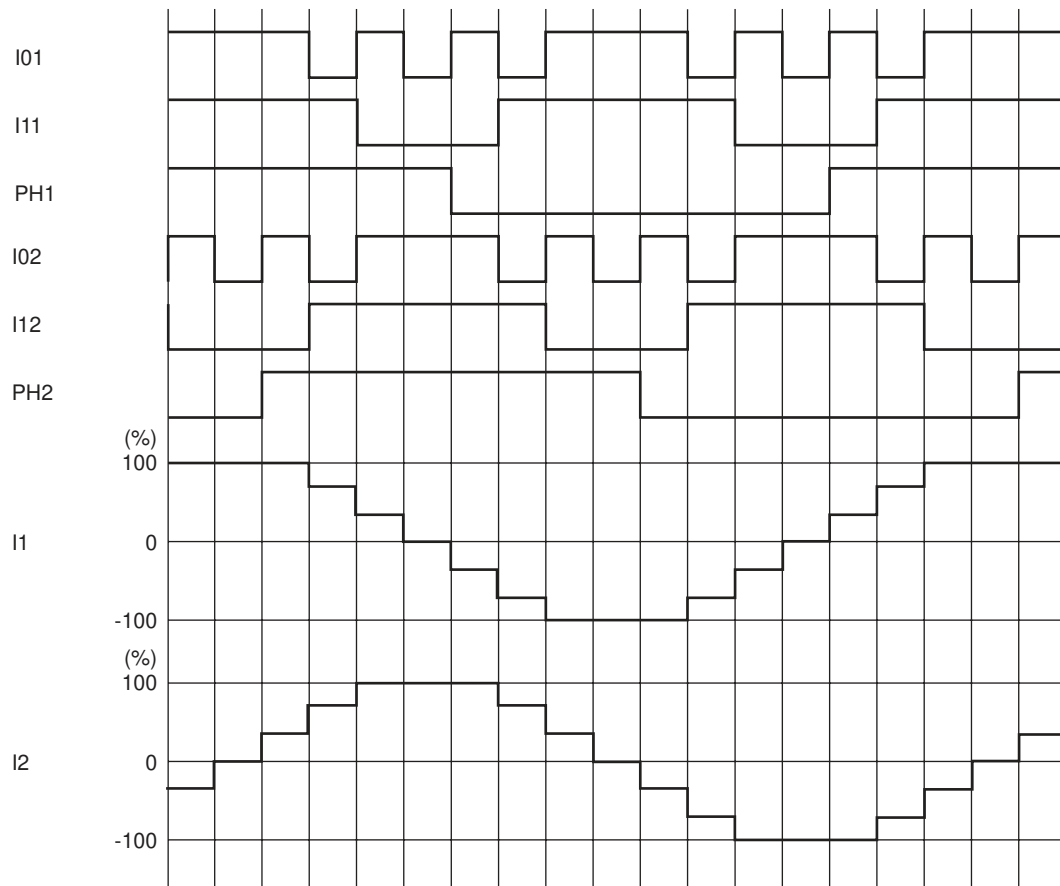

LV8771VH

(8) Charge Pump Circuit

When the ST pin is set High, the charge pump circuit operates and the V_G pin voltage is boosted from the V_M voltage to the $V_M + V_{REG5}$ voltage. Because the output is not turned on if $V_M + 4V$ or more is not pressured, the voltage of the V_G pin recommends the drive of the motor to put the time of t_{ONG} or more, and to begin.

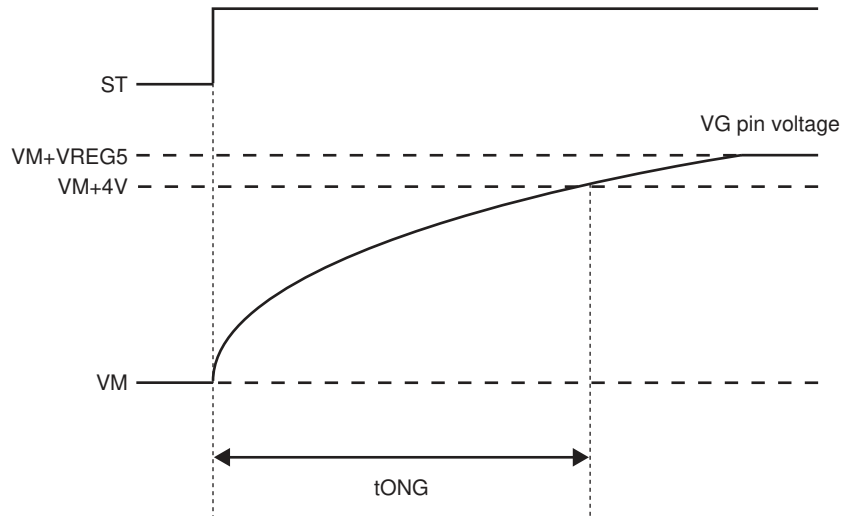

VG Pin Voltage Schematic View

LV8771VH

Application Circuit Example

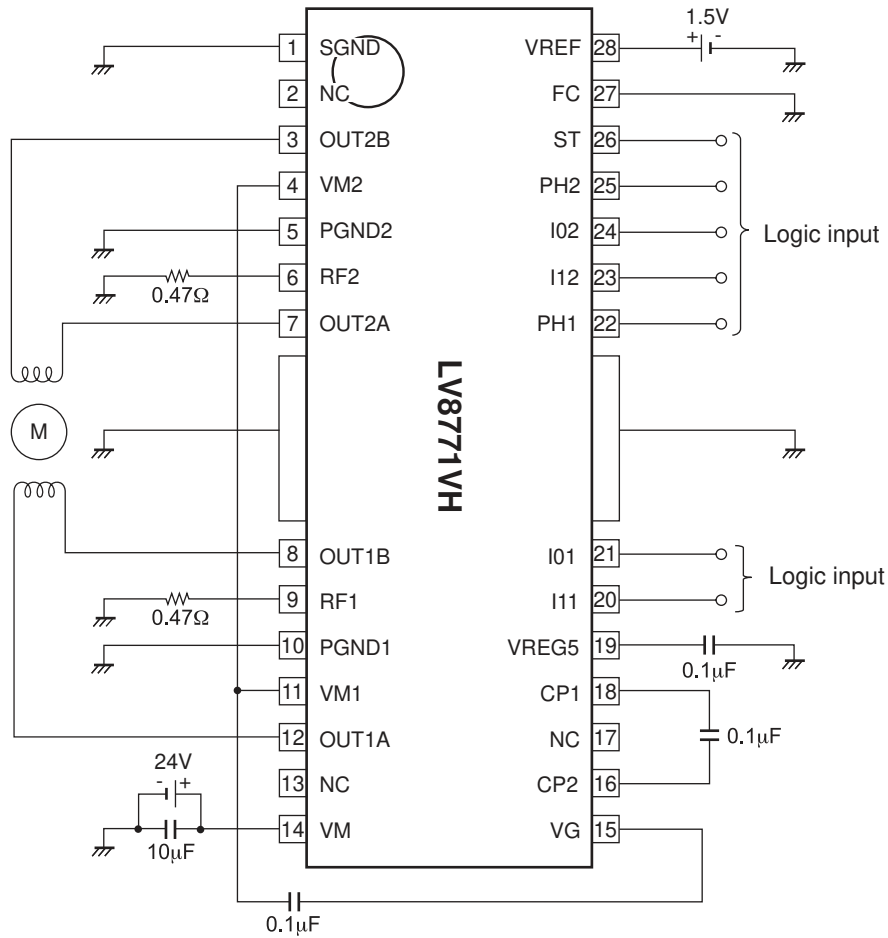

Each constant setting formula of above circuit example is as below.

Setting of chopping frequency: 31kHz (FC = Low)

The setting constant-current level becomes like a list.

(Example) I01(02) = High, I11(12) = High

When VREF = 1.5V, RF = 0.47Ω

$$I_{OUT} = VREF / 5 / RF \text{ resistance}$$

$$= (1.5V / 5) / 0.47\Omega = 0.64A$$

I01(02)	I11(12)	Output current (I _O)
Low	Low	0
High	Low	$I_O = ((VREF / 5) / RF) \times 40\%$
Low	High	$I_O = ((VREF / 5) / RF) \times 70\%$
High	High	$I_O = (VREF / 5) / RF$

PH1(2)	Current direction
Low	OUTB → OUTA
High	OUTA → OUTB

ON Semiconductor and the ON logo are registered trademarks of Semiconductor Components Industries, LLC (SCILLC). SCILLC owns the rights to a number of patents, trademarks, copyrights, trade secrets, and other intellectual property. A listing of SCILLC's product/patent coverage may be accessed at www.onsemi.com/site/pdf/Patent-Marking.pdf. SCILLC reserves the right to make changes without further notice to any products herein. SCILLC makes no warranty, representation or guarantee regarding the suitability of its products for any particular purpose, nor does SCILLC assume any liability arising out of the application or use of any product or circuit, and specifically disclaims any and all liability, including without limitation special, consequential or incidental damages. "Typical" parameters which may be provided in SCILLC data sheets and/or specifications can and do vary in different applications and actual performance may vary over time. All operating parameters, including "Typicals" must be validated for each customer application by customer's technical experts. SCILLC does not convey any license under its patent rights nor the rights of others. SCILLC products are not designed, intended, or authorized for use as components in systems intended for surgical implant into the body, or other applications intended to support or sustain life, or for any other application in which the failure of the SCILLC product could create a situation where personal injury or death may occur. Should Buyer purchase or use SCILLC products for any such unintended or unauthorized application, Buyer shall indemnify and hold SCILLC and its officers, employees, subsidiaries, affiliates, and distributors harmless against all claims, costs, damages, and expenses, and reasonable attorney fees arising out of, directly or indirectly, any claim of personal injury or death associated with such unintended or unauthorized use, even if such claim alleges that SCILLC was negligent regarding the design or manufacture of the part. SCILLC is an Equal Opportunity/Affirmative Action Employer. This literature is subject to all applicable copyright laws and is not for resale in any manner.