

Molded SMD Power Inductor



ASPIAIG-Q1030

Request Samples



Check Inventory



11.9 x 11.0 x 2.9 mm
RoHS/RoHS II Compliant
MSL Level = 1

Features

- PPAP ready and supported
- TS16949 certified production lines
- AEC-Q200 Grade 0 qualified (-55°C ~ +155°C)
- Shielded construction
- Soft saturation
- Low DCR, High Efficiency

Applications

- Body electronics and comfort system
- Infotainment and entertainment
- Electric vehicles
- Lighting
- Solar inverters and power
- Industrial and robotics
- Medium and high power switch mode power supplies.

Electrical Specifications

Part Number	Inductance	Tolerance	DC Resistance	Saturation Current	Temperature Rise Current
	0.1MHz/0.1V		Max	Max	Max
Units	μH	%	mΩ	A	A
Symbol	L		DCR	Isat	Irms
ASPIAIG-Q1030- R28	0.28	±20	1.60	58.0	35.0
ASPIAIG-Q1030- R56	0.56	±20	2.75	39.0	32.0
ASPIAIG-Q1030- R82	0.82	±20	4.10	32.0	25.0
ASPIAIG-Q1030- R90	0.90	±20	4.20	31.0	24.0
ASPIAIG-Q1030- 1R0	1.0	±20	4.95	30.0	23.0
ASPIAIG-Q1030- 1R5	1.5	±20	6.60	25.0	18.0

Test Conditions

Isat: DC current at which the inductance drops 30% from its value without current.

Irms: DC current that causes the temperature rise (ΔT , approximate 40 °C) from 20°C ambient

Operating Temperature: -55°C ~ +155°C (including self-temperature rise)

Storage Condition: -55°C ~ +155°C (PCB mounted) and R.H. 60 max

Operating Voltage: 40V (across inductor)

ASPIAIG-Q1030 Series is **RoHS Compliant and Pb free**

ASPIAIG-Q1030 is AEC-Q200 Grade 0 qualified (-55°C ~ +155°C)

MSL level: 1

Part Number Identification



5101 Hidden Creek Ln Spicewood TX 78669
Phone: 512-371-6159 | Fax: 512-351-8858
For terms and conditions of sales, please visit:
www.abracon.com

REVISED: 02-08-21

ABRACON IS
ISO9001-2015
CERTIFIED

Molded SMD Power Inductor



ASPIAIG-Q1030

Request Samples



Check Inventory



11.9 x 11.0 x 2.9 mm
RoHS/RoHS II Compliant
MSL Level = 1

ASPIAIG – Q1030 - -

Inductance Code

See Electrical Specification table

Tolerance

M = $\pm 20\%$

Packaging

T: Tape and Reel (1000 pcs / reel)

Marking

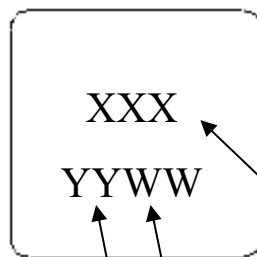

Inductance Code

e.g. 6R8

W: Week: E.g. 05 for the 5th week of the year.

Y: Year: E.g. 20 for 2020

Marking Method = Ink Marking

Molded SMD Power Inductor



ASPIAIG-Q1030

Request Samples



Check Inventory



11.9 x 11.0 x 2.9 mm
RoHS/RoHS II Compliant
 MSL Level = 1

Mechanical Dimensions

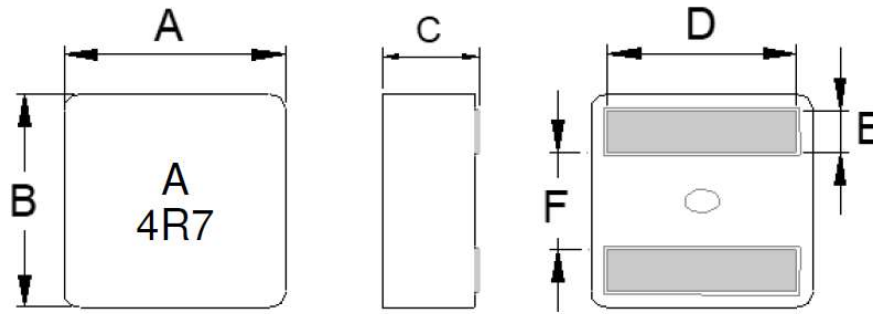

Series	A	B	C	D	E	F
ASPIAIG-Q1030	11.9 ± 0.3	11.0 ± 0.3	2.9 ± 0.2	9.0 ± 0.5	2.4 ± 0.2	4.4 ± 0.3

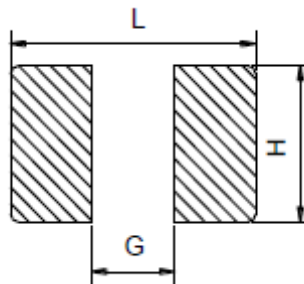

L	G	H
10.5 Ref.	3.7 Ref.	11.0 Ref.

Dimensions: mm

Molded SMD Power Inductor



ASPIAIG-Q1030

Request Samples



Check Inventory



11.9 x 11.0 x 2.9 mm
RoHS/RoHS II Compliant
MSL Level = 1

Materials

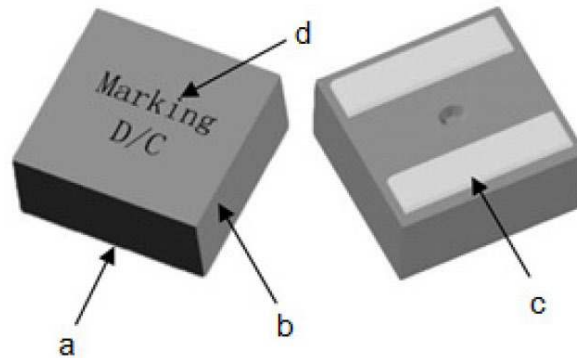

	Components	Material
a	Core	Alloy powder
b	Wire	220 deg. C Flat Wire
c	Solder	100% Pb free solder
d	Ink	Halogen-free ketone

Molded SMD Power Inductor



ASPIAIG-Q1030

Request Samples



Check Inventory



11.9 x 11.0 x 2.9 mm
RoHS/RoHS II Compliant
MSL Level = 1

Reflow Profile

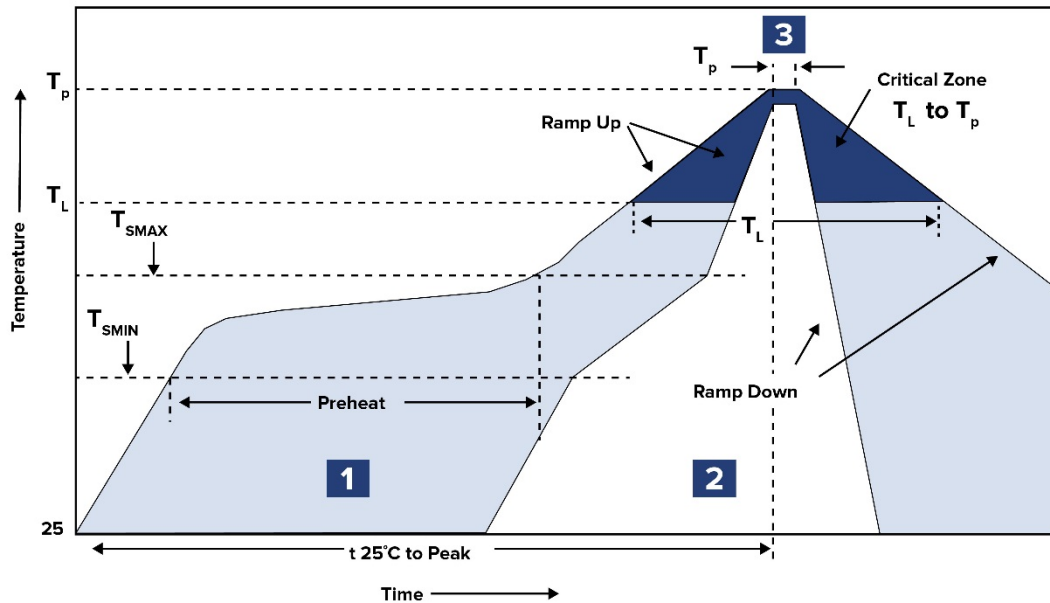

Zone	Description	Temperature	Times
1	Preheat	$T_{SMIN} \sim T_{SMAX}$ 150°C ~ 200°C	60 ~ 180 sec.
2	Reflow	T_L 217°C	60 ~ 150 sec.
3	Peak heat	T_P 260°C	10 sec. MAX

Molded SMD Power Inductor



ASPIAIG-Q1030

Request Samples



Check Inventory



11.9 x 11.0 x 2.9 mm
RoHS/RoHS II Compliant
MSL Level = 1

Packaging

Tape & Reel: 1000 pcs/reel

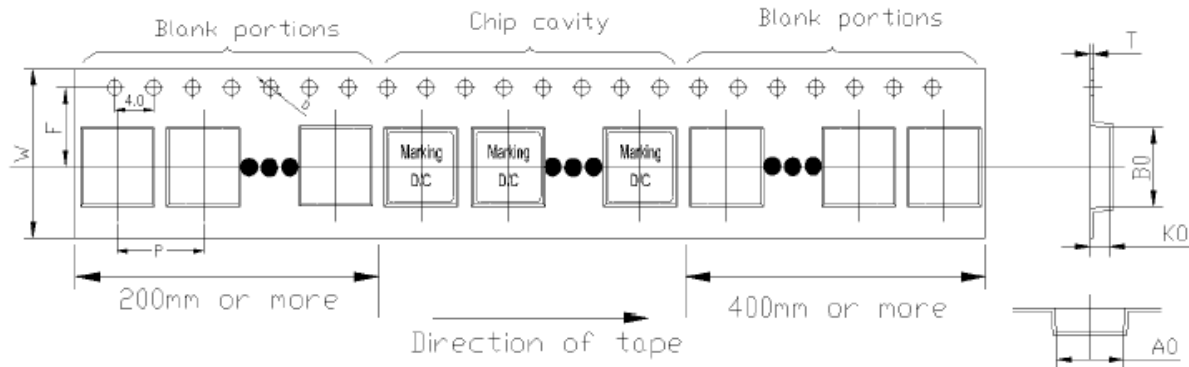

W	F	P	D	A ₀	B ₀	T	K ₀
24.0±0.3	11.5±0.1	16.0±0.1	1.5±0.1	12.4±0.1	11.5 ±0.1	0.35±0.1	4.5±0.1

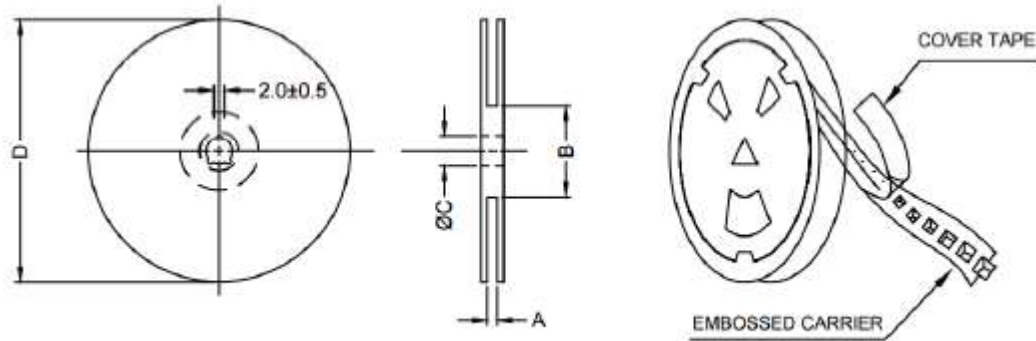

A	B	C	D
24.4+2/-0	100 ± 2	13.0+0.5/-0.2	330

ATTENTION: Abracon LLC's products are COTS – Commercial-Off-The-Shelf products; suitable for Commercial, Industrial and, where designated, Automotive Applications. Abracon's products are not specifically designed for Military, Aviation, Aerospace, Life-dependent Medical applications or any application requiring high reliability where component failure could result in loss of life and/or property. For applications requiring high reliability and/or presenting an extreme operating environment, written consent and authorization from Abracon LLC is required. Please contact Abracon LLC for more information.



5101 Hidden Creek Ln Spicewood TX 78669
 Phone: 512-371-6159 | Fax: 512-351-8858
 For terms and conditions of sales, please visit:
www.abracon.com

REVISED: 02-08-21

ABRACON IS
 ISO9001-2015
 CERTIFIED