

Common Mode Choke for Automotive Signal Line CMA0805 Series

FEATURES AND APPLICATIONS

Laird CMA0805 series automotive common mode chokes improve performance and reliability. A low profile and compact design benefits automotive electronics, industrial and telecom design. Products feature superior common mode noise suppression over broadband frequency and reduce customer total EMC cost. Chokes are designed in wire wound construction and perform in extended operating temperature range.

FEATURES

- Magnetic wire-wound structure
- Superior common mode noise suppression over broadband frequency
- Low profile and extremely small size

APPLICATIONS

- Automotive CAN-BUS Signal Lines
- Telecom and Industrial Singal Lines



PART NUMBER EXPLANATION

CMA	0805	A	201R	- 1A
Product series code	Dimension code	Material code	Impedance code	Automotive code

NOTES

- Reliability test referring to AEC-Q200 standard
- Operating Temperature range :
 CMA0805A Series -40°C to +125°C (Including self - temperature rise)
- Storage Condition (Component in its packaging) . Temperature : Less than 40°C .Humidity : 60% RH
- Storage Temp : -55°C to +85°C (On board)
- At Rated Current < 1A , Temperature Rise 20°C Max .
- For automotive application with PPAP requirement, a specific P/N suffix will be assigned to replace P/N suffix -1A, please contact your local Laird contacts for details

Rev	Items	Before	After	Owner	Date
A	—	—	—	Jon Liu	2021.9.8

1.CMA0805 SERIES DIMENSIONS

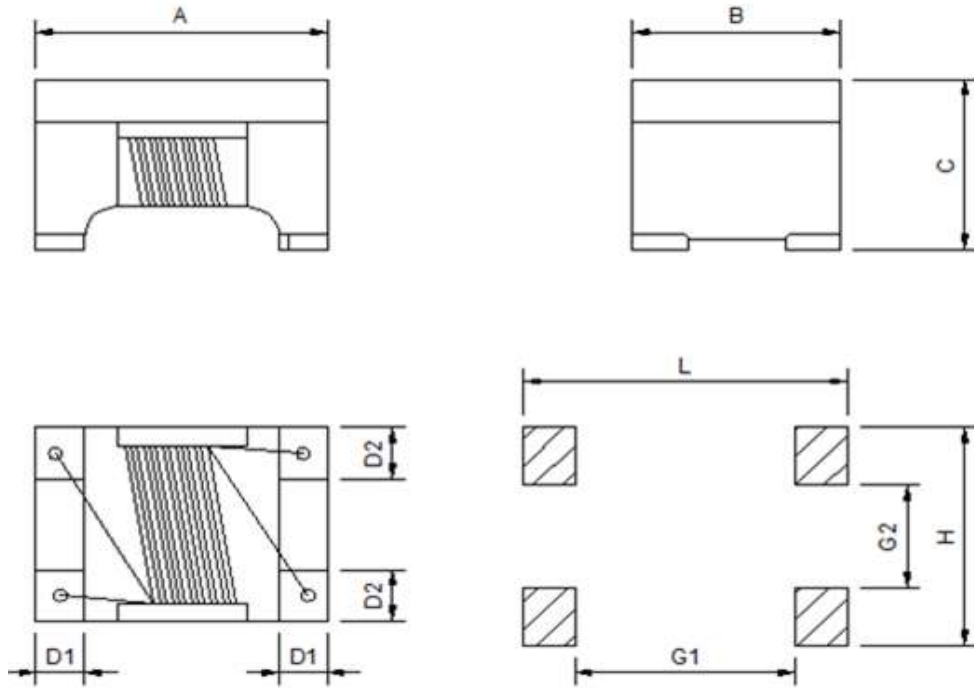

CMA0805 Series

Recommended layout

A	B	C	D1	D2	L	H	G1	G2
2.0±0.2	1.2±0.2	1.2±0.2	0.55 Ref	0.45Ref	2.6 REF	1.25 REF	1.1 REF	0.45 REF

2.SPECIFICATION

Part No.	Common Mode Impedance(ohm) 100MHz/0.5V	Insulation Test Voltage V/AC Max	DC Resistance (ohm) Max	Rated Current (mA)	Rated Volt (Vdc)	IR (Mohm) Min
CMA0805A900R-1A	90±25%	125	0.19	400	50	10
CMA0805A121R-1A	120±25%	125	0.22	370	50	10
CMA0805A201R-1A	200±25%	125	0.25	350	50	10
CMA0805A361R-1A	360±25%	125	0.50	220	50	10
CMA0805A681R-1A	680±25%	125	1.30	200	50	10

3.EQUIVALENT CIRCUIT

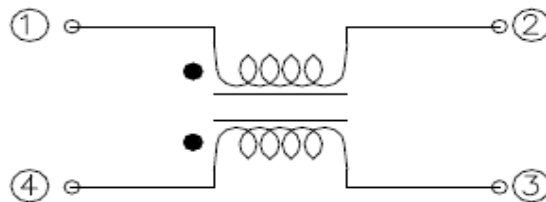

4.MATERIAL LIST

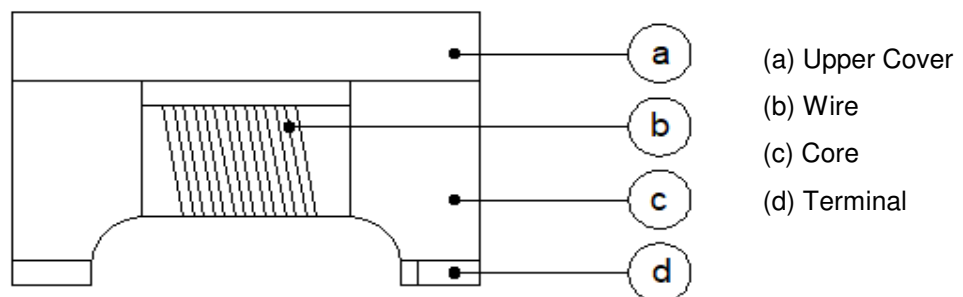

5. CHARACTERISTICS CURVES

COMMON MODE IMPEDANCE

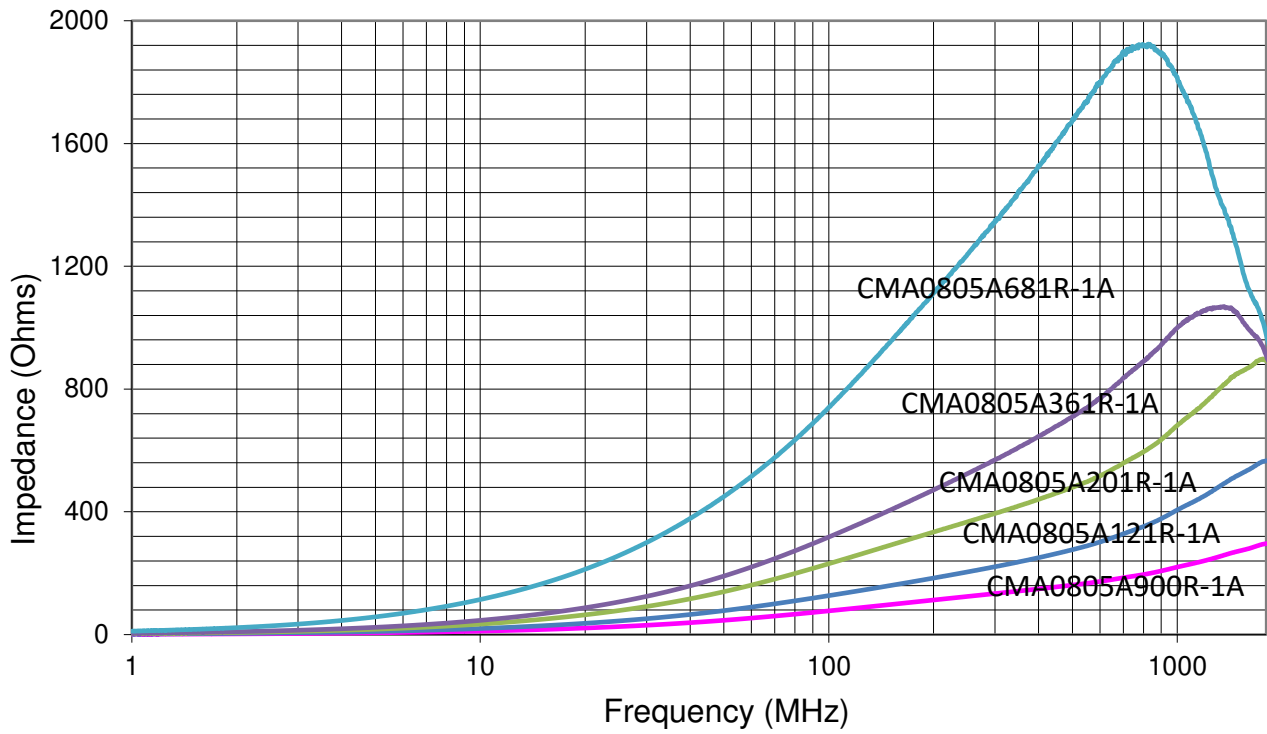

DIFFERENTIAL MODE IMPEDANCE

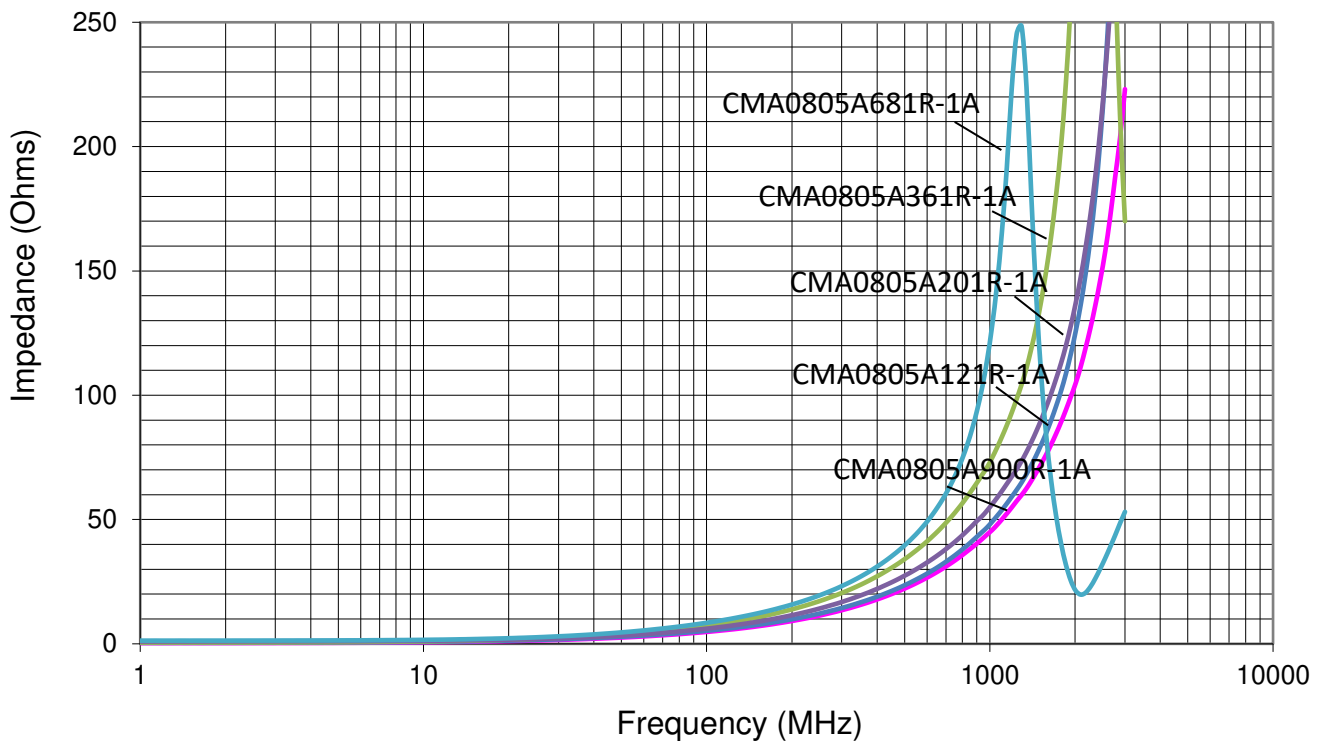

6. SOLDERING

Mildly activated rosin fluxes are preferred.

Recommended temperature profiles for re - flow soldering in Figure 1 .

Temperature Profile

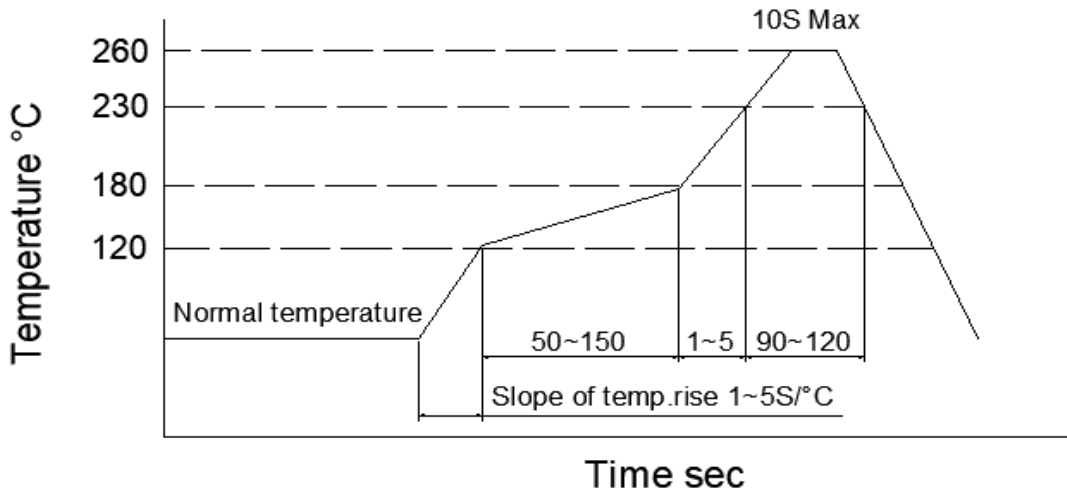

Reworking with soldering iron

Preheating	150°C 1 minute
Tip temperature	280°C max
Soldering time	3 seconds max
Soldering iron output	30w max
End of soldering iron	f 3mm max

Reworking should be limited to only one time.

Note : Do not directly touch the products with the tip of the soldering iron in order to prevent the crack on the ferrite material due to the thermal shock.

Solder Volume

Solder shall be used not to be exceed the upper limits as shown below.

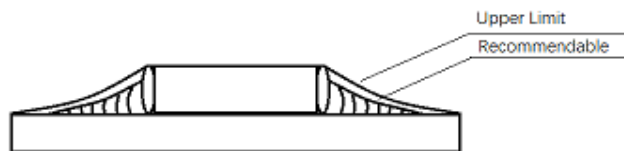

When solder volume is increased ,the mechanical stress to product is also increased . Exceeding solder volum may cause the failure of mechanical or 1 performance.

7.RELIABILITY





<i>ITEM</i>	<i>CONDITION</i>	<i>SPECIFICATION</i>
Terminal Strength	Reference : AEC-Q200-006 Force : 5N Dwell : 60+1 sec	1. No visible mechanical damage 2. Impedance or inductance change within user spec 3. 30pcs
High Temperature Exposure	Reference : MIL-STD-202 Method 108 125°C 100hrs.	1. No visible mechanical damage 2. Impedance or inductance change within user spec 3. 77pcs
Temperature Cycling	Reference : JESD22 , Method JA-104 -40°C to 125°C ,1000 cycles	1. No visible mechanical damage 2. Impedance or inductance change within user spec 3. 77pcs
Biased Humidity	Reference : MIL-STD-202 Method 103 85°C,85%RH 1000hrs, Unpowered	1. No visible mechanical damage 2. Impedance or inductance change within user spec 3. 77pcs
Operational Life	Reference : MIL-PPF-27 125°C (Including self-heating) 1000hrs , rated current applied (as the part drawing)	1. No visible mechanical damage 2. Impedance or inductance change within user spec 3. 77pcs
Solderability	Reference : J-STD-002 Method D ,category 3, 260±5°C , 5±1 sec, Solder : 96.5Sn/3.0 Ag/0.5Cu	1. No visible mechanical damage 2. Wetting shall be exceed 95% coverage 3.30pcs
Resistance to soldering Heat	Reference : MIL-STD-202 Method 210 Condition B No pre-heat of samples. SMD : Procedure 2 Leaded : Procedure 1	1. No visible mechanical damage 2. Impedance or inductance change within user spec 3. 30pcs
Mechanical Shock	Reference :MIL-STD-202 Method 213 Figure 1 of method 213 SMD :Condition F Leaded : Condition C	1. No visible mechanical damage 2. Impedance or inductance change within user spec 3. 30pcs

<i>ITEM</i>	<i>CONDITION</i>	<i>SPECIFICATION</i>
Vibration	Reference : MIL-STD-202 Method 204 5 g` s for 20 minutes . 10-2000Hz 12 cycles each of 3 orientations	1. No visible mechanical damage 2. Impedance or inductance change within user spec 3. 30pcs
Board Flex	Reference: AEC-Q200-005 2mm (min) Dwell :60 +1 sec	1. No visible mechanical damage 2. Impedance or inductance change within user spec 3. 30pcs
External Visual	No any defect found after visual inspection for all samples.	
Physical dimension	No dimension issue found after dimension measurement for 30 pcs samples.	
Electrical characterization	Remark : Performance for all samples can meet spec.	

8. TERMINAL TO BE TESTED

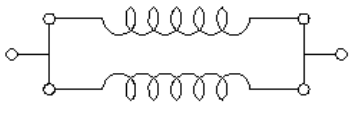
Terminal to be Tested

When measuring and supplying the voltage , the following terminal is applied.

No.	ITEM	TERMINAL TO BE TESTED
1	Common Mode Impedance	
2	DC Resistance	
3	Rated Current	
4	Insulation Resistance	
5	Withstanding Voltage	

7. PACKAGING

7-1 Reel Dimension

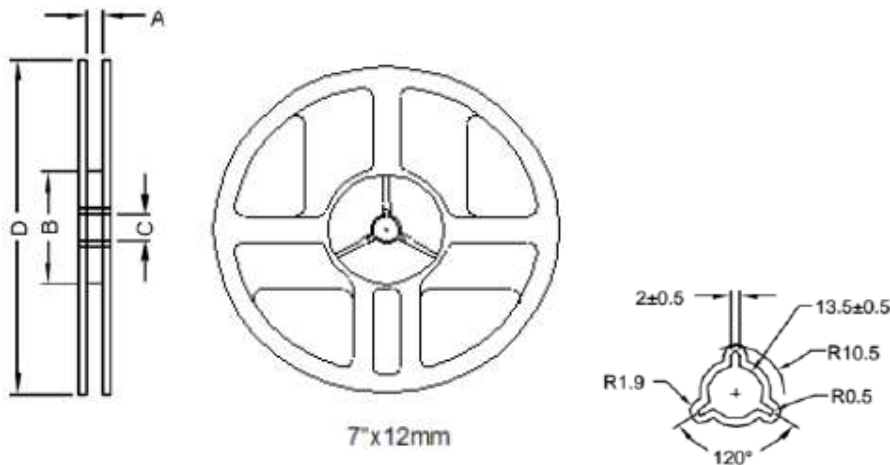

Size	Type	A(mm)	B(mm)	C(mm)	D(mm)
CMA0805	7"x8mm	9.0±0.5	60.0±2.0	13.5±0.5	178.0±2.0

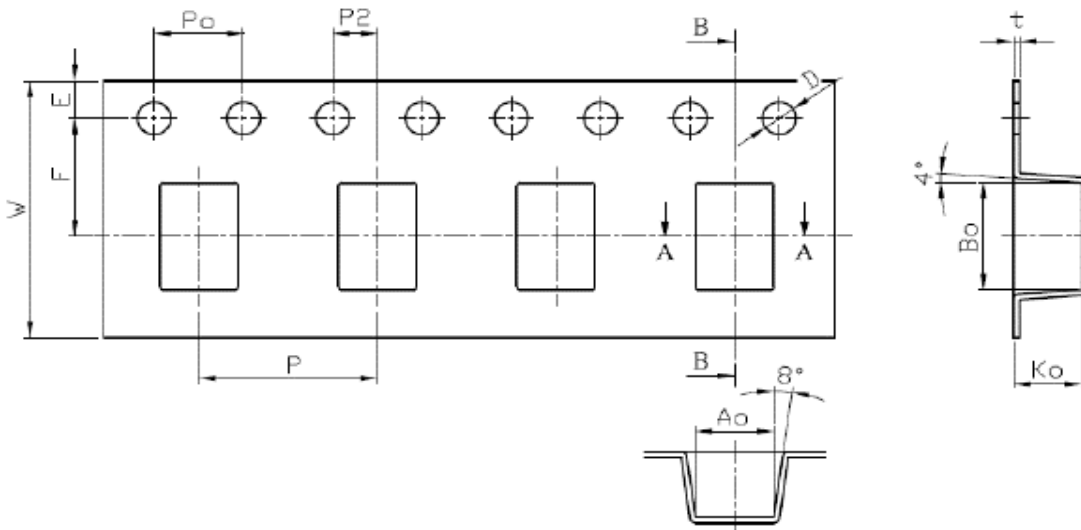

Size	P(mm)	P0(mm)	P2(mm)	B0(mm)	A0(mm)	K0(mm)	D(mm)	E(mm)	F(mm)	W(mm)	T(mm)
CMA0805	4.0±0.1	4.0±0.1	2.0±0.1	2.35±0.1	1.5±0.1	1.67±0.15	1.55±0.1	1.75±0.1	3.5±0.05	8.0±0.1	0.22±0.05

Size	Reel	Inner Box	Outer Box
CMA0805	2000	10000	60000

7-2 Tearing Off Force

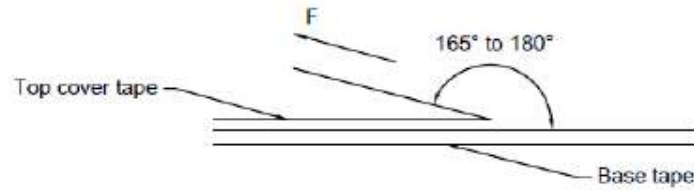

The force for tearing off cover tape is 10~100 grame in the arrow direction under the following conditions .

Room Temp (°C)	Room Humidity(%)	Room atm (hPa)	Tearing Speed mm/min
5~35	45~85	860~1060	300

8. Application Notice:

1.Storage Conditions:

To maintain the solderability of terminal electrodes:

- a) Recommended products should be used within 12 months from the time of delivery .
- b) The packaging material should be kept where no chlorine or sulfur exists in the air .

2. Transportation:

- a) Products should be -handled with care to avoid damage or contamination from perspiration and skin oils .
- b) Vacuum pick up is strongly recommended for individual components .
- c) Bulk handling should ensure that abrasion and mechanical shock are minimized .